

INSTALLATION INSTRUCTIONS

**WALL MOUNTED
PACKAGE AIR CONDITIONERS**

MODELS

MAC30A

MAC36A

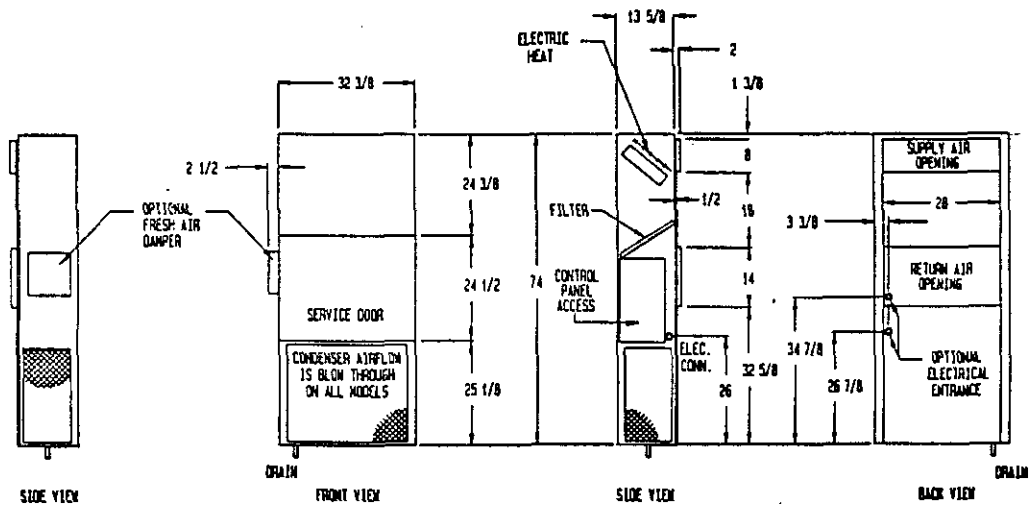

SPECIFICATIONS

MODEL	MAC30A-A00	MAC30A-A05	MAC30A-A10	MAC30A-A15	MAC36A-A00	MAC36A-A05	MAC36A-A10	MAC36A-A15
Heater Kw @ 240/208V	None	5/3.75	10/7.5	15*/11.25	None	5/3.75	10/7.5	15*/11.25
Cooling Capacity Btuh	30,600	30,600	30,600	30,600	35,400	35,400	35,400	35,400
Heating Capacity Btuh**	None	19,000/ 15,000	36,000/ 27,000	53,000/ 40,000	None	19,000/ 15,000	36,000/ 27,000	53,000/ 40,000
Electrical Rating -- 60Hz	230/208-1	230/208-1	230/208-1	230/208-1	230/208-1	230/208-1	230/208-1	230/208-1
Operating Voltage Range	197-253	197-253	197-253	197-253	197-253	197-253	197-253	197-253
Minimum Circuit Ampacity	25	31	57	83	30	31	57	83
No. Field Power Ckts.	1	1	1	1	1	1	1	1
**Field Wire Size	#10	#8	#4	#2	#10	#8	#4	#2
Ground Wire Size	#10	#10	#10	#8	#10	#10	#10	#8
***Req'd Max. External Fuses	40	40	60	90+	45	45	60	90+
Total Unit Amps 240/208	18.3/19.8	24.7/22.0	45.5/40.1	66.4/58.0	22.3/23.8	24.7/23.8	45.5/40.1	66.4/58.0
Internal Fuses (Standard)	None	None	None	60/30	None	None	None	60/30
Internal Circuit Breakers (Option C)	40	40	60	60, 30	45	45	60	60, 30
Compressor -- Circuit A								
Volts	230/208				230/208			
Rated Load Amps 230/208	13/14.5				17/18.5			
Branch Circuit Selection Current	15.5				19.5			
Lock Rotor Amps	81/81				97/97			
Fan Motor & Condenser								
Fan Motor -- HP/RPM	1/5/1050				1/5/1050			
Fan Motor -- AMPS	1.4				1.4			
Fan -- DIA/CFM	20"/1800				20"/1800			
Face Area								
Sq.Ft./Row/Fins per in.	4.7/2/12				4.7/2/12			
Motor and Evaporator								
Blower Motor -- HP/RPM	1/2/1600				1/2/1600			
Blower Motor - Amps	3.9				3.9			
CFM Cooling & F.S.P. w/Filter (Rated) (Hi)	1000/.30				1060/.15			
Face Area								
Sq.Ft./Row.Fins per in.	2.7/2/13				2.7/2/13			
Filter Sizes (Inches)	14x25x1				14x25x1			
Refrigerant 22 -- oz.	62				56			
Shipping Weight -- lbs.	310				315			

*15Kw models must be installed using high speed only.

**60°C copper wire size.

***Maximum time delay fuse or HACR type circuit breaker.

+Sizes 70A or greater are not HACR type.

**Includes blower motor.

Specifications subject to change without notice.

NOMENCLATURE EXPLANATION

Example:

MAC36A-A10/C

- Basic Model
- Modification Code
- Optional Equipment (Built in Circuit Breakers)
- KW Electric Heat
- Electrical Characteristics (230/208-1-60)
- Nominal Capacity

IMPORTANT

While this electrical data is presented as a guide, it is important to electrically connect, properly sized fuses and conductor wires in accordance with the National Electrical Code and all existing local codes.

CERTIFIED LISTED

Underwriters Listed for outdoor installation

IMPORTANT

The equipment covered in this manual is to be installed by trained, experienced service and installation technicians. Any heat pump is more critical of proper operating, charge and an adequate duct system than a straight air conditioning unit. All duct work supply and return, must be properly sized for the design air flow requirement of the equipment. ACCA is an excellent guide to proper sizing. All duct work or portions thereof not in the conditioned space should be properly insulated in order to both conserve energy and prevent condensation or moisture damage.

SHIPPING DAMAGE

Upon receipt of equipment, the carton should be checked for external signs of shipping damage. If damage is found, the receiving party must contact the last carrier immediately, preferably in writing, requesting inspection by the carrier's agent.

GENERAL

The refrigerant system is completely assembled and charged. All internal wiring is complete.

The unit is designed for use with or without duct work. Flanges are provided for attaching the supply and return ducts.

These instructions explain the recommended method to install the air cooled self-contained unit and the electrical wiring connections to the unit.

These instructions and any instructions packaged with any separate equipment required to make up the entire air conditioning system should be carefully read before beginning the installation. Note particularly "Starting Procedure" and any tags and/or labels attached to the equipment.

While these instructions are intended as a general recommended guide, they do not supersede any national and/or local codes in any way. Authorities having jurisdiction should be consulted before the installation is made.

INSTALLATION

Size of unit for a proposed installation should be based on heat loss calculation made according to methods of Air Conditioning Contractors of America (ACCA). The air duct should be installed in accordance with the Standards of the National Fire Protection Association for the Installation of Air Conditioning and Ventilating systems of Other Than Residence Type, NFPA No. 90A, and Residence Type Warm Air Heating and Air Conditioning Systems, NFPA No. 90B. Where local regulations are at a variance with instructions, installer should adhere to local codes.

DUCT WORK

Design the duct work according to methods given by the Air Conditioning Contractors of America. When duct runs through unheated spaces, it should be insulated with a minimum of one inch of insulation. Use insulation with a vapor barrier on the outside of the insulation. Flexible joints should be used to connect the duct work to the equipment in order to keep the noise transmission to a minimum.

A one-inch clearance to combustible material for the first three feet of duct attached to the outlet air frame is required. See page 3 for further details.

FILTER

A one inch throwaway filter is supplied with each unit. The filter slides into position making it easy to service. This filter can be serviced from the outside by removing the service door.

FRESH AIR INTAKE

All units are built with a fresh air inlet opening punched in the left unit side. This opening is covered by a factory installed blank off plate, model BOP20.

A fresh air damper assembly, model FAD20, may be ordered separately to accommodate the variety of state and local codes requiring fresh air capability.

All capacity, efficiency and cost of operation information as required for Department of Energy "EnergyGuide" fact sheets is based on the fresh air blank off plate being in place and is recommended for maximum energy efficiency.

WALL MOUNTING

1. Two holes, the size of the supply and return air openings must be cut through the wall as shown in Figure 2.
2. On wood-frame walls, the wall construction must be strong and rigid enough to carry the weight of the unit without transmitting any unit vibration.
3. Concrete block walls must be thoroughly inspected to insure that they are capable of carrying the weight of the installing unit.
4. Ducts through the walls must be insulated and all joints taped or sealed to prevent air or moisture entering the wall cavity.
5. Some installations may not require any return air duct. It is recommended that on this type of installation that a filter grille be located in the wall. Filters must be of sufficient size to allow a maximum velocity of 400 FPM.

NOTE: If no return air duct is used, applicable installation codes may limit this cabinet to installation only in a single story structure.

WIRING - MAIN POWER

Refer to the unit rating plate for wire sizing information and maximum fuse or "HACR Type" circuit breaker size. Each outdoor unit is marked with a "Minimum Circuit Ampacity." This means that the field wiring used must be sized to carry that amount of current. Some models are suitable only for connection with copper wire, while others can be wired with either copper or aluminum wire. Each unit and/or wiring diagram will be marked "Use Copper Conductors Only" or "Use Copper or Aluminum Conductors." These instructions MUST BE adhered to. Refer to the National Electrical Code for complete current carrying capacity data on the various insulation grades of wiring material.

The electrical data lists fuse and wire sizes (60°C copper) for all models, including the most commonly used heater sizes.

The unit rating plate lists a "Maximum Time Delay Relay Fuse" or "HACR Type" circuit breaker that is to be used with the equipment. The correct size must be used for proper circuit protection and also to assure that there will be no nuisance tripping due to the momentary high starting current of the compressor motor.

FIGURE 1.

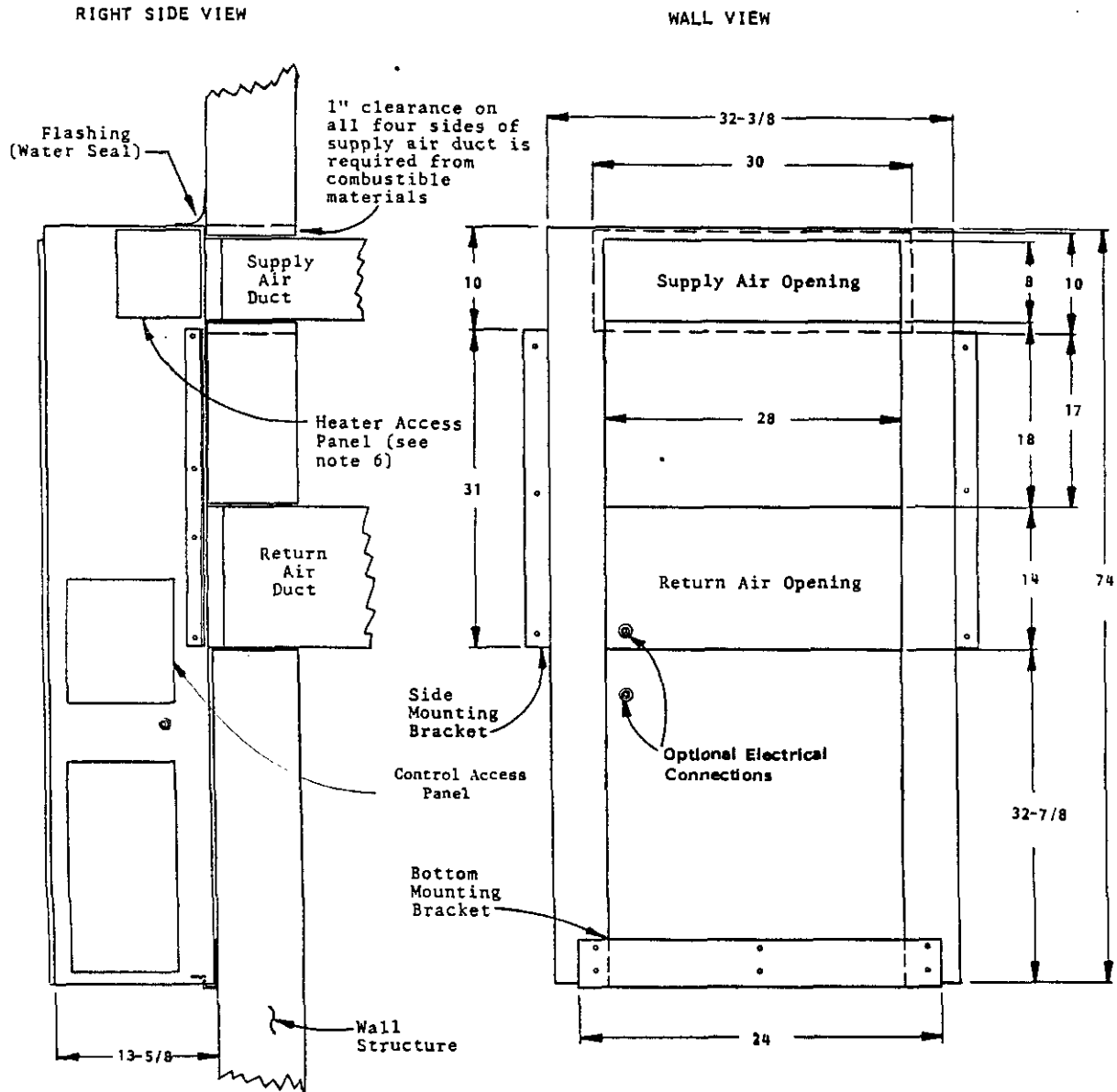

MOUNTING INSTRUCTIONS

1. These units are secured by wall mounting brackets which secure the unit to the outside wall surface at both sides and at the bottom.
2. The unit itself is suitable for "0" inch clearance, but the supply air duct flange and the first few feet of supply air duct require 1 inch clearance to combustible material. If combustible wall, use 30"x10" dimensions for sizing, if non-combustible, use 28"x8" dimensions.
3. After the wall opening positions have been selected, lay out the position for the bottom and side brackets. Fasten the brackets securely to the wall (type of fasteners will depend on wall construction).
4. Be sure to observe the 10" dimension when attaching the side brackets. This will assure that no screws are driven into the unit sides damaging any internal parts. One-half inch sheet metal screws are recommended.
5. For additional mounting rigidity, the return air and supply air (depending upon wall construction) frames or collars can be drilled and screwed or welded to the structural wall itself. Be sure to observe required clearance if combustible wall.
6. Maintain 30 inches minimum clearance on right side of unit to allow access to heat strip and control panel.

FAN BLADE SETTING DIMENSIONS

Shown in the drawing below are the correct fan blade setting dimensions for proper air delivery across the outdoor coil.

Any service work requiring removal or adjustment in the fan and/or motor area will require that the dimensions below be checked and blade adjusted in or out on the motor shaft accordingly.

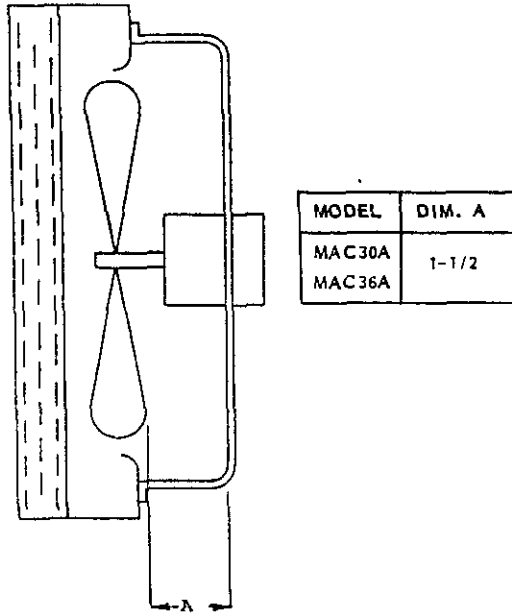

INDOOR BLOWER PERFORMANCE

All units are factory shipped wired on high speed tap. If low static operation is needed, low speed may be used for all except 15kw models. All 15kw models must be applied using high speed only. Refer to the chart below for CFM outputs at various E.S.P. conditions.

INDOOR BLOWER PERFORMANCE CFM - Dry Coil		
E.S.P. Inches H ₂ O	MAC30A, MAC36A	
	High	Low*
.0	1200	975
.10	1160	930
.20	1120	900
.30	1075	
.40	1035	
.50	970	

*MAC30A and MAC36A models with 15kw electric heat must use high speed only.

If this unit is operated in cooling below a 65° outdoor ambient temperature, the installation of low ambient control (LAC-1) to unit is required.

REFRIGERANT CHARGE

The correct system R-22 charge is shown on the unit rating plate. Optimum unit performance will occur with a refrigerant charge resulting in a suction line temperature (6" from compressor) as shown in the following table:

Model	Rated Airflow	95°F OD Temp.	82°F OD Temp.
MAC30A	1000	53 - 55	60 - 62
MAC36A	1060	50 - 52	54 - 56

The above suction line temperatures are based upon 80°F dry bulb/67°F wet bulb (50% R.H.) temperature and rated airflow across the evaporator during cooling cycle.

RATED CFM AND E.S.P. (WET COIL--COOLING)			
Model	Rated CFM *	Rated E.S.P. *	Recommended Airflow Range
MAC30A	1000	.30	900 - 1100
MAC36A	1060	.15	900 - 1160

*Rated CFM and ESP on high speed tap.

IMPORTANT INSTALLER NOTE

For improved start-up performance wash the indoor coil with a dishwasher detergent.

PRESSURE SERVICE PORTS

High and low pressure service ports are installed on all units so that the system operating pressures can be observed. Pressure curves can be found later in the manual covering all models on both cooling and heating cycles. It is imperative to match the correct pressure curve to the unit by model number.

PARTS LIST

Single Package Air Conditioners

Part No.	Description	MAC30A	MAC30A-A05	MAC30A-A10	MAC30A-A15	MAC30A-A00/C	MAC30A-A05/C	MAC30A-A10/C	MAC30A-A15/C	MAC36A	MAC36A-A05	MAC36A-A10	MAC36A-A15	MAC36A-A00/C	MAC36A-A05/C	MAC36A-A10/C	MAC36A-A15/C
		5152-054	Blower Housing	x	x	x	x	x	x	x	x	x	x	x	x	x	x
5152-055	Blower Wheel	x	x	x	x	x	x	x	x	x	x	x	x	x	x	x	x
5152-056	Blower Wheel	x	x	x	x	x	x	x	x	x	x	x	x	x	x	x	x
8552-035	Capacitor 40/370V	x	x	x	x	x	x	x	x								
8552-028	Capacitor 35/440V									x	x	x	x	x	x	x	x
8552-002	Capacitor 5/370V	x	x	x	x	x	x	x	x	x	x	x	x	x	x	x	x
8552-004	Capacitor 7½/370V	x	x	x	x	x	x	x	x	x	x	x	x	x	x	x	x
8000-092	Compressor H23A303ABCA	x	x	x	x	x	x	x	x								
8000-087	Compressor H23A383ABCA									x	x	x	x	x	x	x	x
5051-048	Condenser Coil	x	x	x	x	x	x	x	x	x	x	x	x	x	x	x	x
8401-007	Contactora	x	x	x	x	x	x	x	x	x	x	x	x	x	x	x	x
8401-006	Contactora		x	x			x	x			x	x			x	x	
8401-002	Contactora				x				x				x				x
5060-048	Evaporator Coil	x	x	x	x	x	x	x	x	x	x	x	x	x	x	x	x
5151-032	Fan Blade	x	x	x	x	x	x	x	x	x	x	x	x	x	x	x	x
7004-006	Filter 14x25x1	x	x	x	x	x	x	x	x	x	x	x	x	x	x	x	x
8614-022	Fuse TR60				2								2				
8614-006	Fuse OT30				2								2				
8614-017	Fuse Block 15kw				1								1				
7051-021	Grille - Condenser	x	x	x	x	x	x	x	x	x	x	x	x	x	x	x	x
7051-022	Grille - Inlet	x	x	x	x	x	x	x	x	x	x	x	x	x	x	x	x
8604-042	Heat Strip 5kw		1				1				1				1		
8604-044	Heat Strip 10kw			1				1				1				1	
8604-047	Heat Strip 15kw				1				1				1				1
8402-049	Limit Control		x	x	x		x	x	x		x	x	x		x	x	x
8106-022	Motor - Evaporator	x	x	x	x	x	x	x	x	x	x	x	x	x	x	x	x
8103-019	Motor - Condenser	x	x	x	x	x	x	x	x	x	x	x	x	x	x	x	x
8200-001	Motor Mount (Fan)	x	x	x	x	x	x	x	x	x	x	x	x	x	x	x	x
8200-032	Motor Mount (Blower)	x	x	x	x	x	x	x	x	x	x	x	x	x	x	x	x
8201-009	Relay - Blower	x	x	x	x	x	x	x	x	x	x	x	x	x	x	x	x
8607-013	Terminal Block		x	x							x	x					
8607-018	Terminal Board	x	x	x	x	x	x	x	x	x	x	x	x	x	x	x	x
8402-030	Thermal Cutoff		1	2	3		1	2	3		1	2	3		1	2	3
8407-034	Transformer	x	x	x	x	x	x	x	x	x	x	x	x	x	x	x	x
8615-010	Circuit Breaker													1	1		
8615-014	Circuit Breaker					1	1										
8615-016	Circuit Breaker							1	1							1	1
8615-013	Circuit Breaker								1								1
4081-110	Wiring Diagram	x								x							
4081-111	Wiring Diagram					x								x			
4081-120	Wiring Diagram		x								x						
4081-121	Wiring Diagram						x								x		
4081-130	Wiring Diagram			x								x					
4081-131	Wiring Diagram							x								x	
4081-140	Wiring Diagram				x								x				
4081-141	Wiring Diagram								x								x

Supersedes all previous lists. Subject to change without notice.

These curves are based upon 80°DB, 67°WB R.A. Temp. and rated CFM (airflow) across the evaporator coil and should be used for reference purposes only. Special information can be found under section titled "Refrigerant Charge" elsewhere in manual. If there is any doubt as to correct operating charge being in the system, the charge should be removed, system evacuated, and recharged according to serial plate instructions.

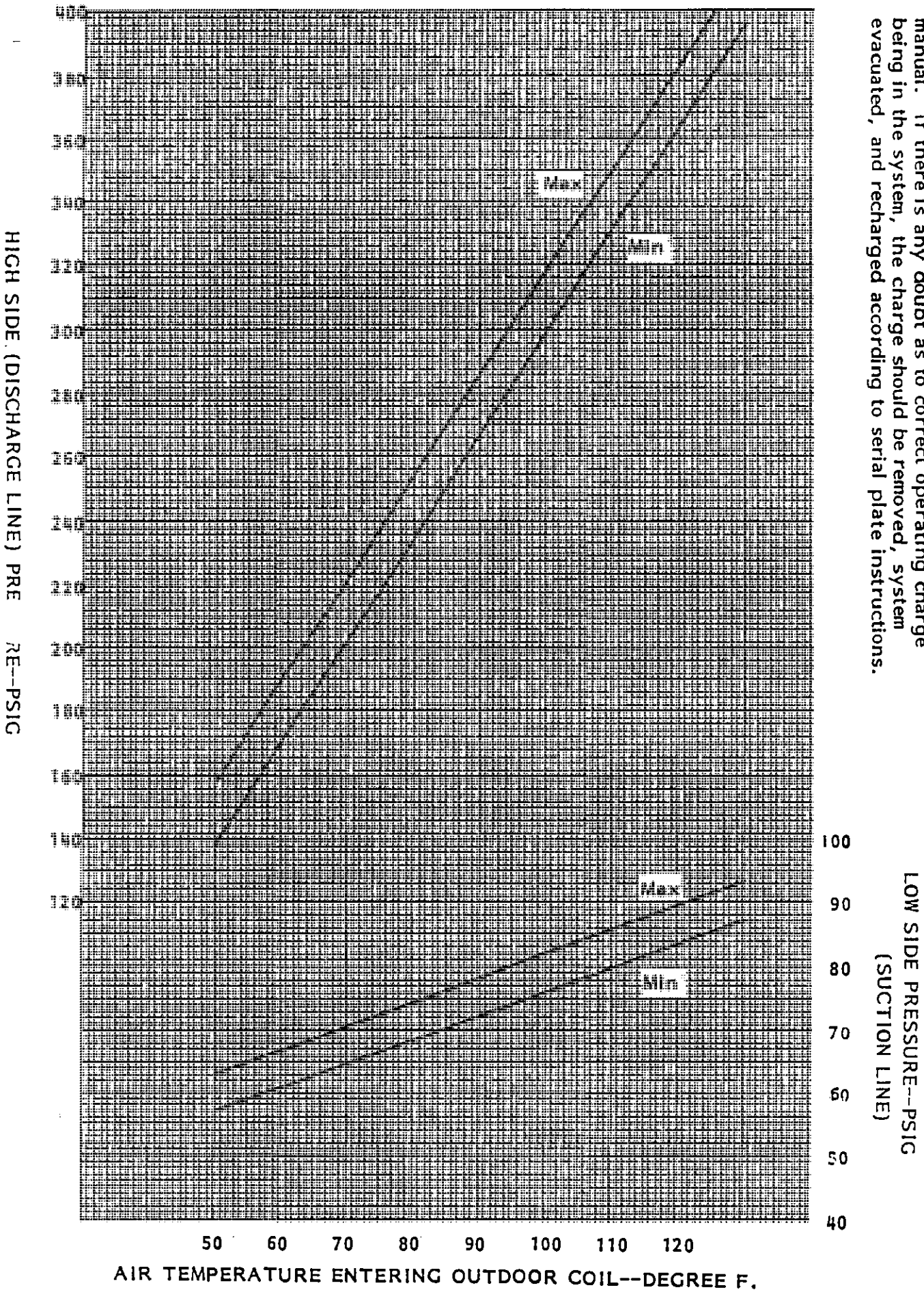

AIR TEMPERATURE ENTERING OUTDOOR COIL--DEGREE F.

PACKAGED AIR CONDITIONER MODEL MAC36A

8/86

These curves are based upon 80°DB, 67°WB R.A. Temp. (airflow) across the evaporator coil and should be used for reference purposes only. Special information can be found under section titled "Refrigerant Charge" elsewhere in manual. If there is any doubt as to correct operating charge being in the system, the charge should be removed, system evacuated, and recharged according to serial plate instructions.

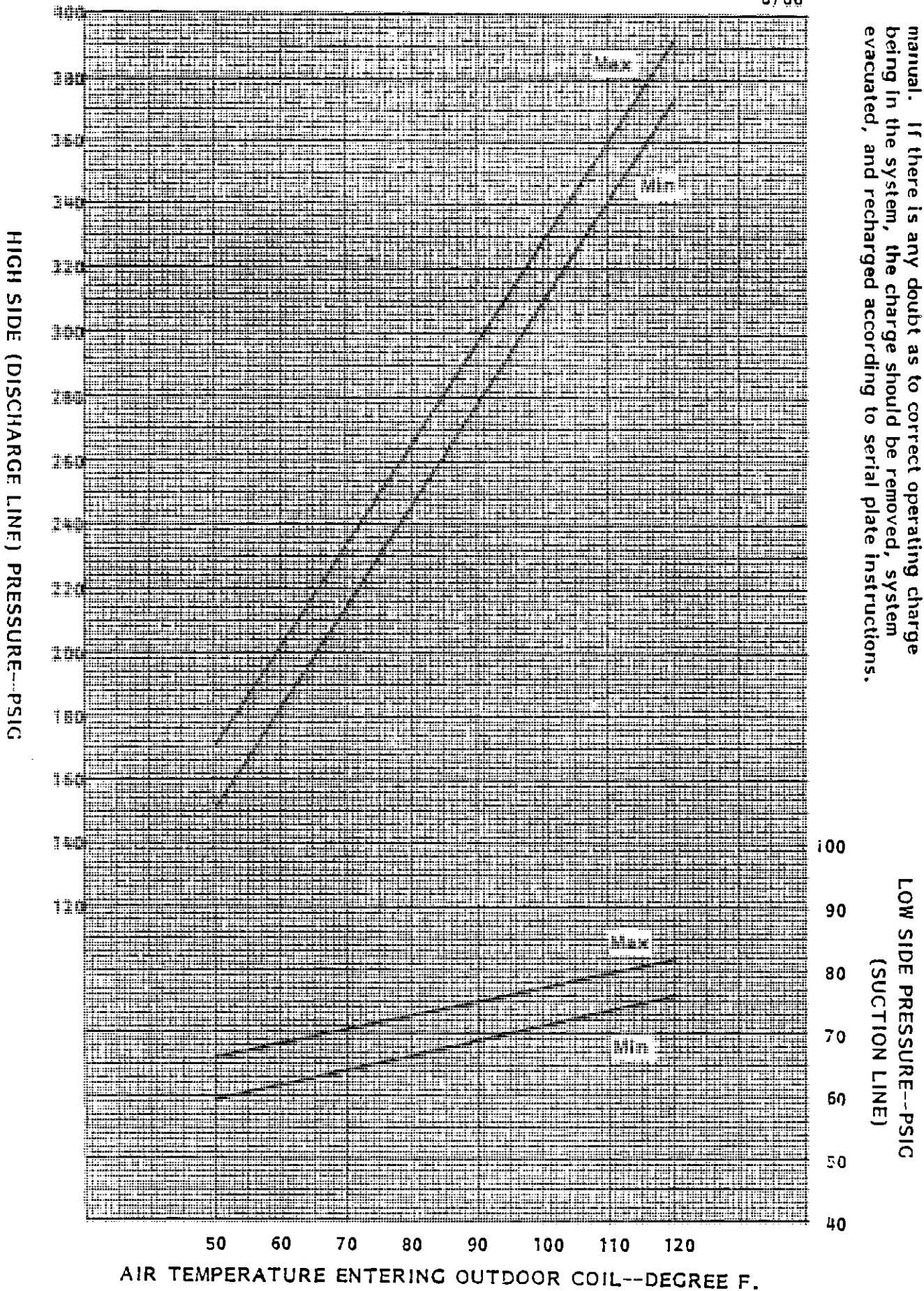

LOW SIDE PRESSURE--PSIG
(SUCTION LINE)

HIGH SIDE (DISCHARGE LINE) PRESSURE--PSIG

AIR TEMPERATURE ENTERING OUTDOOR COIL--DEGREE F.

T874C1000 Thermostat
Q674A1001 Subbase

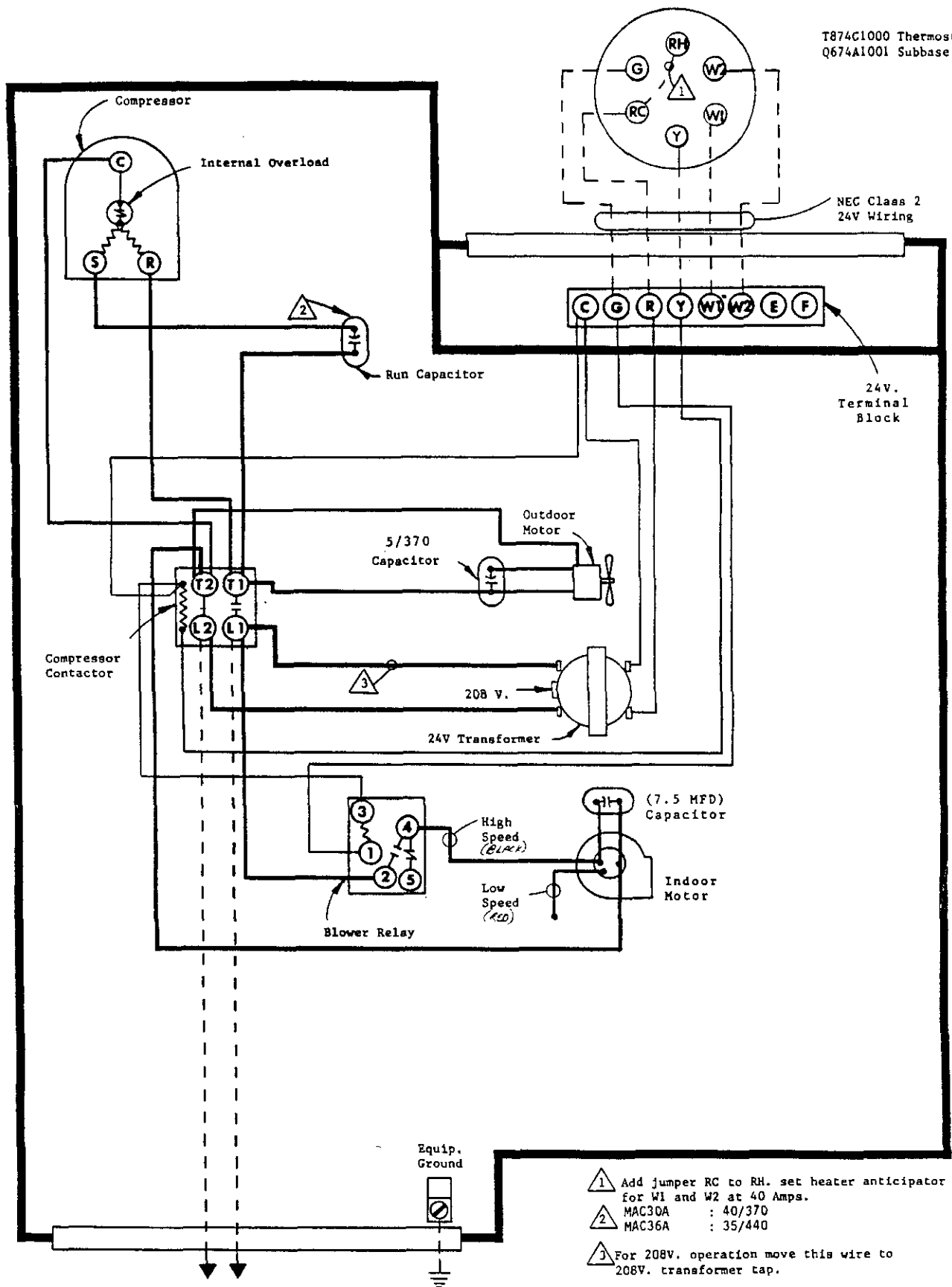

230/208-60-1

USE COPPER WIRE

FACTORY WIRING	FIELD WIRING
Low Voltage	-----
High Voltage	-----

- 1 Add jumper RC to RH. set heater anticipator for W1 and W2 at 40 Amps.
- 2 MAC30A : 40/370
MAC36A : 35/440
- 3 For 208V. operation move this wire to 208V. transformer tap.

T874C1000 Thermostat
Q674A1001 Subbase

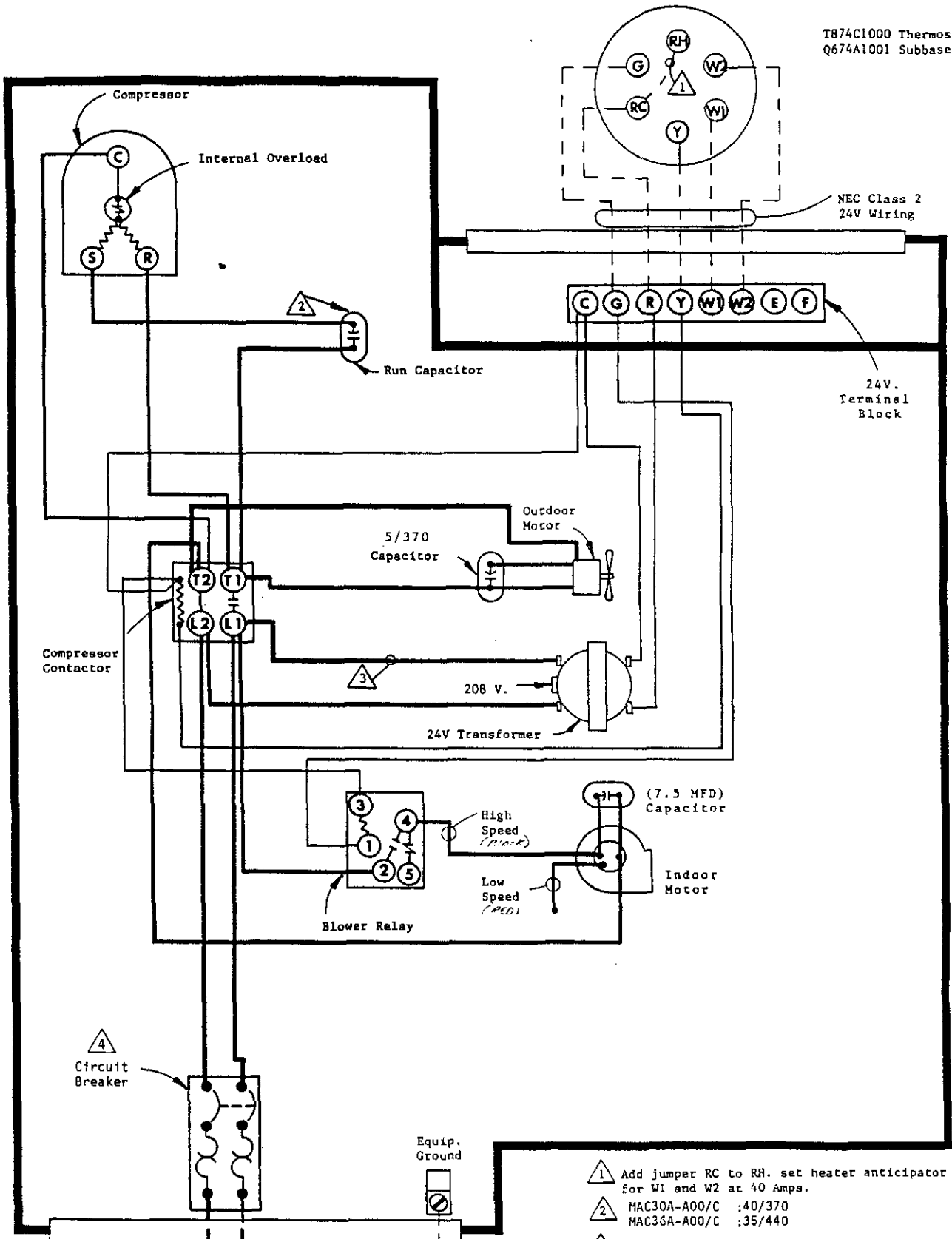

- 1 Add jumper RC to RH. set heater anticipator for W1 and W2 at 40 Amps.
- 2 MAC30A-A00/C :40/370
MAC36A-A00/C :35/440
- 3 For 208V. operation move this wire to 208V. transformer cap.
- 4 MAC30A-A00/C 35A
MAC36A-A00/C 45A

FACTORY WIRING	FIELD WIRING
Low Voltage ———	-----
High Voltage ———	-----

USE COPPER OR ALUMINUM WIRE

T874C1000 Thermostat
Q674A1001 Subbase

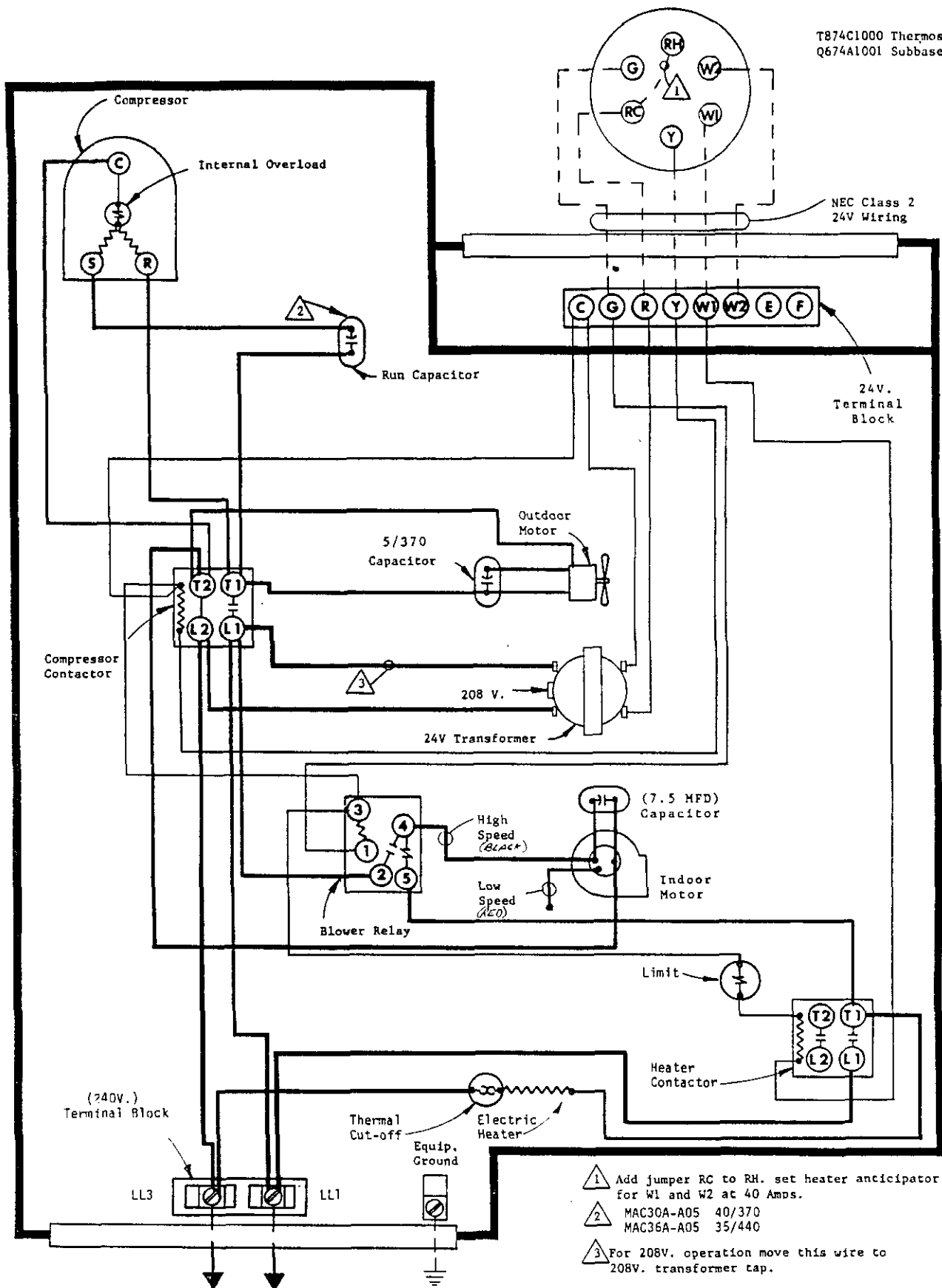

230/208-60-1

FACTORY WIRING	FIELD WIRING
Low Voltage ———	-----
High Voltage ———	-----

USE COPPER OR ALUMINUM WIRE

4031-120 D

T874C1000 Thermostat
Q674A1001 Subbase

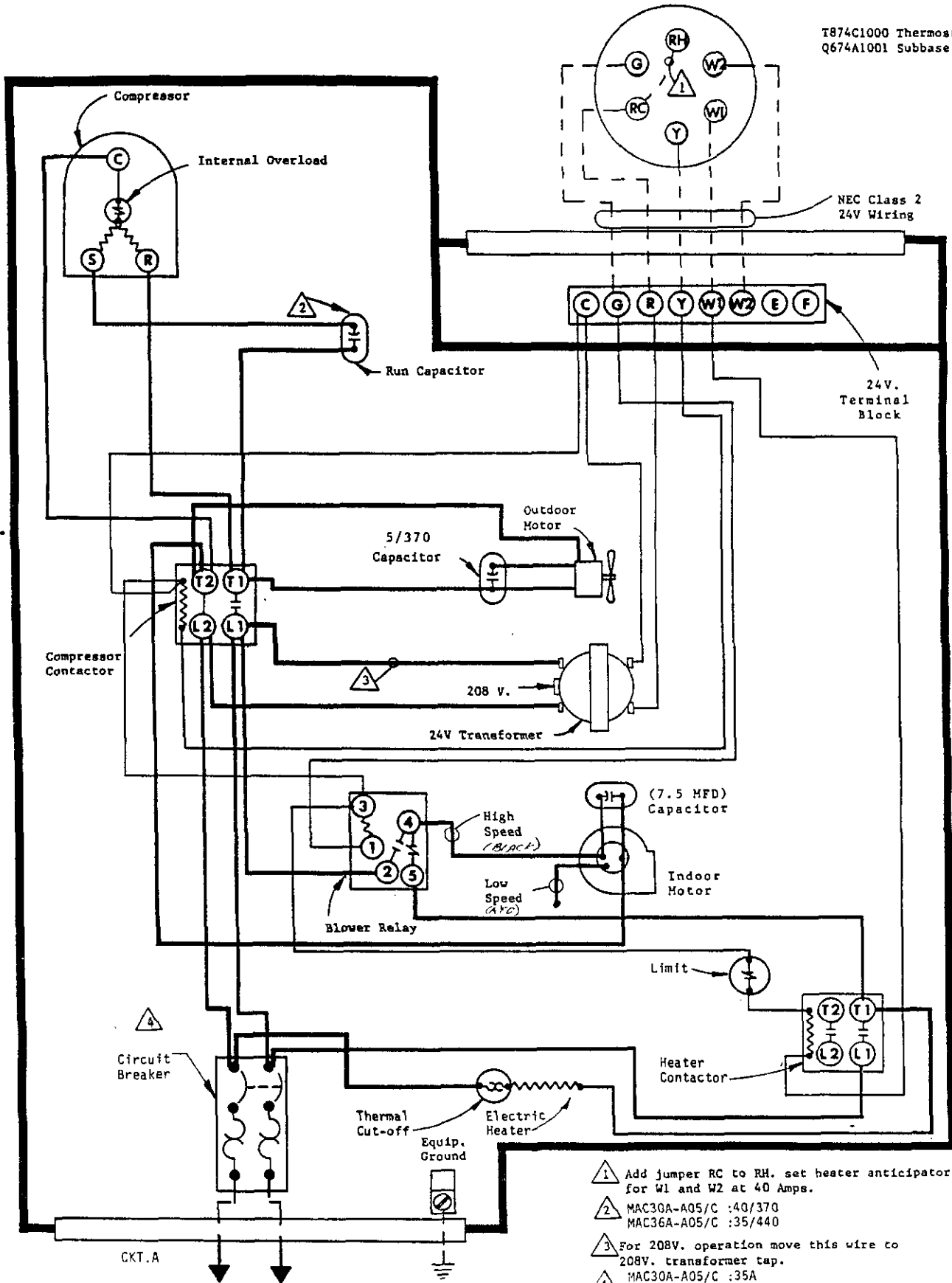

- △ 1 Add jumper RC to RH. set heater anticipator for W1 and W2 at 40 Amps.
- △ 2 MAC30A-A05/C :40/370
MAC36A-A05/C :35/440
- △ 3 For 208V. operation move this wire to 208V. transformer tap.
MAC30A-A05/C :35A
MAC36A-A05/C :45A
- △ 4

230/208-60-1

FACTORY WIRING **FIELD WIRING**
 Low Voltage ————
 High Voltage - - - - -

USE COPPER OR ALUMINUM WIRE

T874C1000 Thermostat
Q674A1001 Subbase

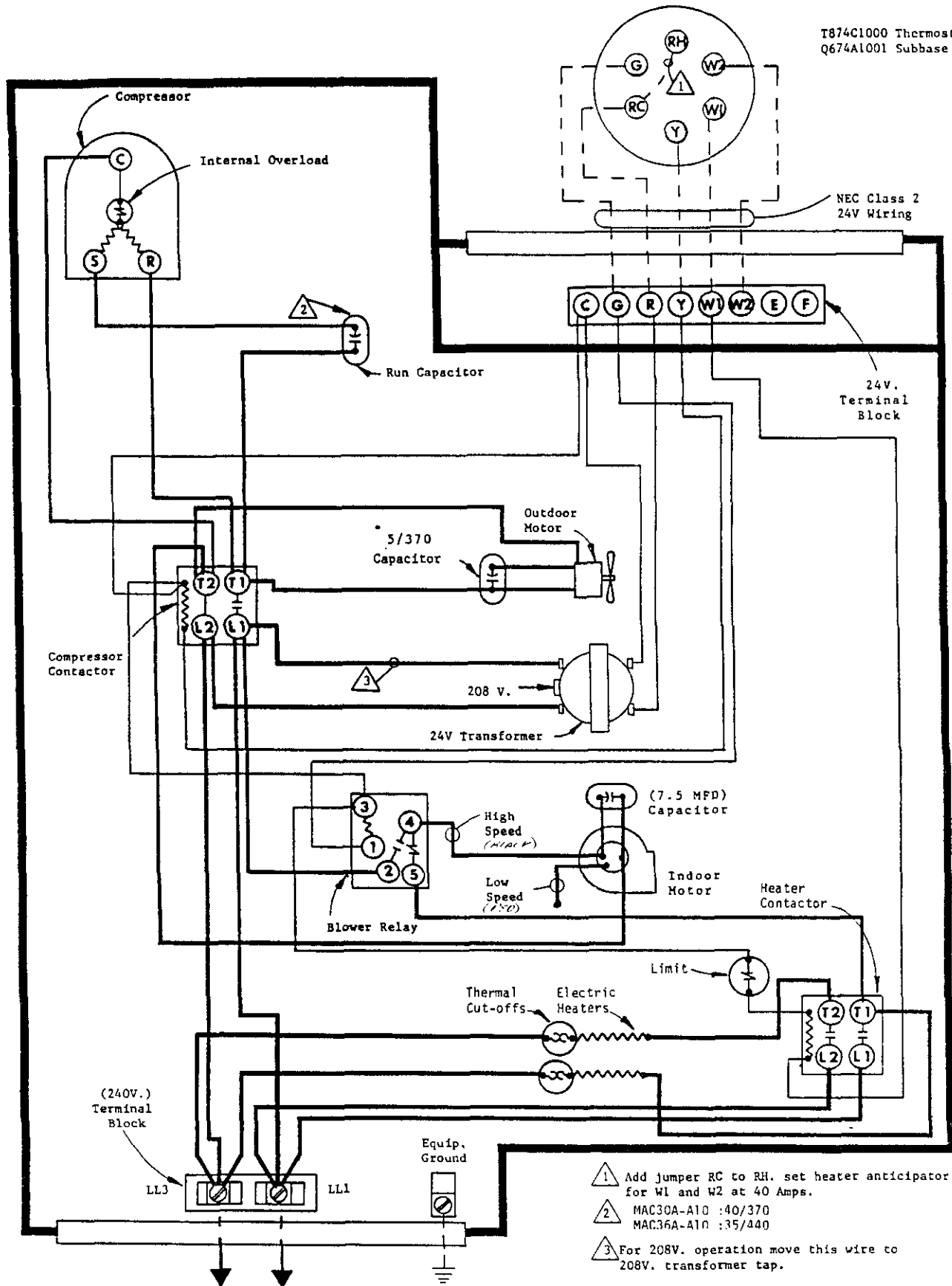

230/208-60-1

- 1 Add jumper RC to RH. set heater anticipator for W1 and W2 at 40 Amps.
- 2 MAC30A-A10 :40/370
MAC36A-A10 :35/440
- 3 For 208V. operation move this wire to 208V. transformer tap.

FACTORY WIRING **FIELD WIRING**
 Low Voltage ————
 High Voltage ————

USE COPPER OR ALUMINUM WIRE

T874C1000 Thermostat
Q674A1001 Subbase

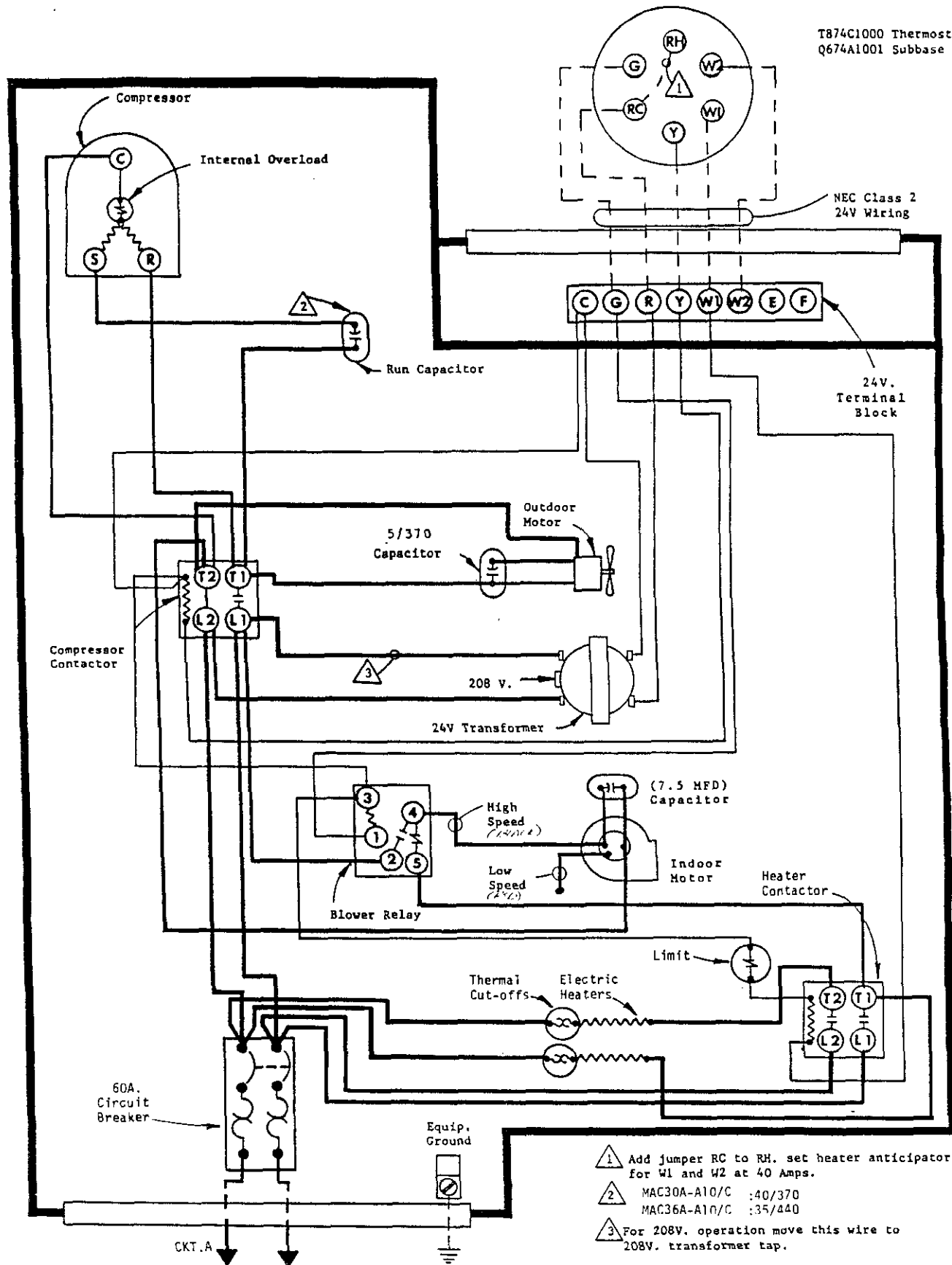

- 1 Add jumper RC to RH, set heater anticipator for W1 and W2 at 40 Amps.
- 2 MAC30A-A10/C :40/370
MAC36A-A10/C :35/440
- 3 For 208V. operation move this wire to 208V. transformer tap.

230/208-60-1

FACTORY WIRING	FIELD WIRING
Low Voltage	-----
High Voltage	-----

USE COPPER OR ALUMINUM WIRE

T874C1000 Thermostat
Q674A1001 Subbase

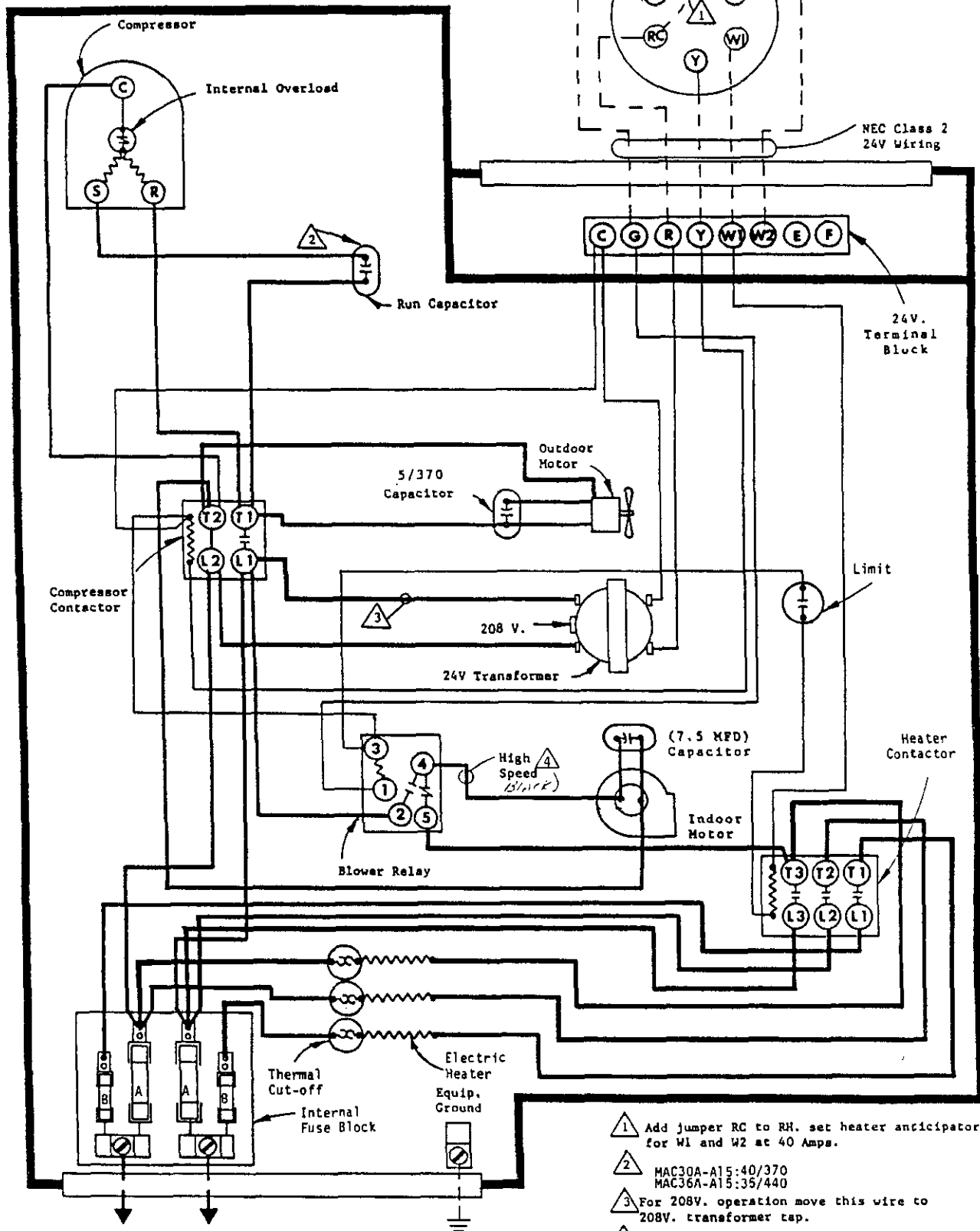

- ⚠️ Add jumper RC to RH. set heater anticipator for W1 and W2 at 40 Amps.
- ⚠️ MAC30A-A15:40/370
MAC36A-A15:35/440
- ⚠️ For 208V. operation move this wire to 208V. transformer tap.
- ⚠️ This model not approved and must not be operated on low speed.

NOTE: Fuse A -60A Time Delay
Fuse B -30A
All Fuses Type K-5

FACTORY WIRING	FIELD WIRING
Low Voltage ———	-----
High Voltage ———	-----

USE COPPER OR ALUMINUM WIRE

T874C1000 Thermostat
Q674A1001 Subbase

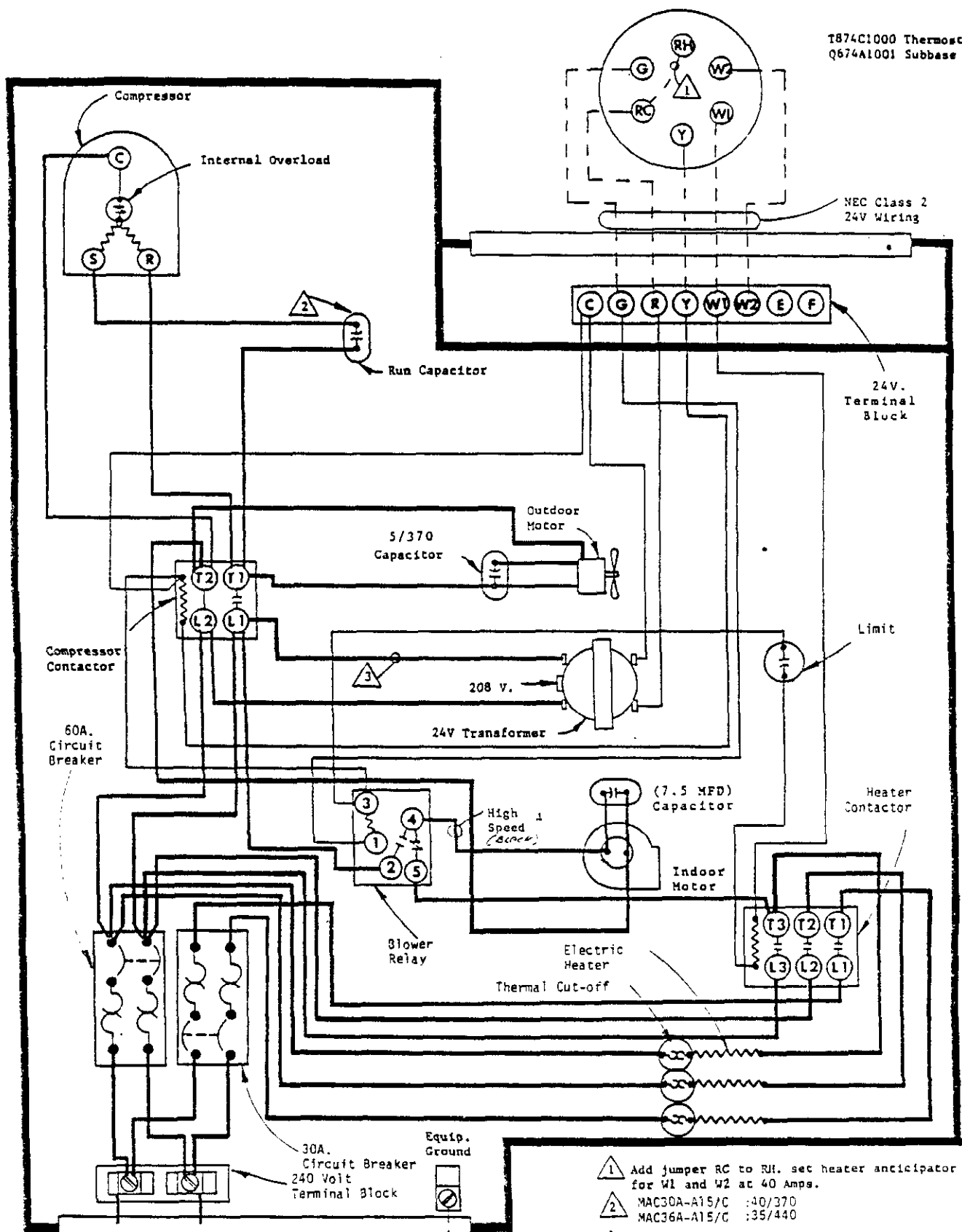

- 1 Add jumper RC to RH. set heater anticipator for W1 and W2 at 40 Amps.
- 2 MAC30A-A15/C :40/370
MAC36A-A15/C :35/440
- 3 For 208V. operation move this wire to 208V. transformer tap.
- 4 This model is not approved and must not be operated on low speed.

230/208-60-1

FACTORY WIRING	FIELD WIRING
Low Voltage ———	-----
High Voltage - - - - -	-----

USE COPPER OR ALUMINUM WIRE