

INSTALLATION INSTRUCTIONS

REMOTE HEAT RECOVERY UNIT

MODEL HRU2-5A



GENERAL

The heat recovery coil should only be installed by trained refrigeration technicians. These instructions serve as a guide to the technician installing the Heat Recovery Unit. They are not intended as a step-by-step procedure with which the mechanically inclined owner can install the unit.

DESCRIPTION

The HRU2-5A is designed to heat domestic water using "waste" heat recovered from a 2 thru 5 ton air conditioner or heat pump's hot discharge gas.

UNPACKING

Upon receipt of the equipment, the carton should be checked for external signs of shipping damage. If damage is found, the receiving party must contact the last carrier immediately, preferably in writing, requesting inspection by the carrier's agent.

LOCATION

The HRU2-5A is recommended to be installed indoors. The unit contains water, and the heat pump may cycle off even at temperatures below freezing--the water is subject to freezing. Because of this, it must be located in the conditioned area crawl space, basement, or utility room in areas where freezing conditions are prevalent in winter.

Locate the storage tank as close to the heat pump end Heat Recovery Unit as the installation permits.

When locating the HRU2-5A and the storage tank, keep in mind refrigerant and water lines should be a maximum of 25 feet long, measured one way. Also, the vertical lift should not exceed 20 feet. This keeps pressure losses and heat losses at a minimum.

INSTALLATION PROCEDURE--GENERAL

Before beginning the installation, turn off all power supplies to the water heater and air conditioner or heat pump and shut off the main water supply line.

TWO TANK. In order to realize the maximum energy savings from the Heat Recovery Unit, it is recommended that a second water storage tank be installed in addition to the main hot water heater. Fossil fuel fired water heaters must be a two-tank installation.

Tanks specifically intended for hot water storage are available from water heater manufacturers (solar hot water storage tanks). A well insulated electric water heater without the electric heating elements connected will also make a suitable storage tank.

The size of storage tank should be as large as space and economy permit but in no event should it be less than one-half of the daily water requirements for the occupants. As a guide in estimating the daily family water requirements, the Department of Energy recommends a figure of 16.07 gallons of hot water per day per individual. For example, a family of four would require 64.3 gallons per day (4 x 16.07).

ONE TANK. The single hot water tank may be a new hot water heater (sized to 100% of daily water requirements) or the existing water heater in the case of a retrofit installation. The existing water heater should be drained and flushed to remove ALL loose sediment. This sediment could damage the circulating pump. The bottom heating element should be disconnected.

WATER PIPING. All water piping must adhere to all state and local codes. Refer to piping diagrams for recommended one and two tank installations. Piping connections are 1/2 inch O.D. copper pipe.

A plugged tee and shut off valve should be provided near the HRU2-5A should cleaning of the water coil become necessary. A cleanable "Y" type strainer should also be included to collect any sediment.

REFRIGERANT CONNECTIONS. After the components in the system are located, the discharge line from the heat pump compressor should be cut down-stream from any external muffler, and high pressure switch, but before the reversing valve. On air conditioning units, the HRU2-5A water heater should be connected between the compressor (high pressure switch if unit is equipped) and the condenser coil.

Refrigeration piping (type L copper tubing) of one-half inch diameter or the size of the discharge line (whichever is larger) should be used. It should be installed from this hot gas line to the inlet refrigerant side of the HRU2-5A water heater. The same size and type refrigerant piping is used to return the hot gas from the outlet refrigerant pipe of the HRU2-5A water heater to the heat pump. This refrigerant line should be insulated with one-half inch Armaflex insulation. Tubing should be protected from abrasion where it is exiting the air conditioner by high temperature grommets or other suitable means.

Good refrigeration service procedures must be followed in the installation of the HRU2-5A water heater. All field refrigerant piping joints must be brazed with a brazing alloy having a working temperature of 1000°F - 1500°F. During the brazing operation, a small amount of dry nitrogen must be continuously bled through the refrigerant piping to displace any air and prevent oxidation and contamination. The system must be evacuated to 500 microns or less. This will remove any moisture and guard against refrigerant leaks. The refrigerant system is then recharged with a charging cylinder. (Since the condenser area has been increased, temperature-pressure charts should not be used, unless the HRU is turned off while servicing the heat pump or air conditioner). Recharge with the manufacturer's recommended charge plus one ounce for every additional ten feet of refrigerant line added.

ELECTRICAL SERVICE. It is recommended that the HRU2-5A water heater be connected to the "line" side of the compressor contactor of an air conditioner (see Figure A). For heat pump installation, Figure B shows the typical recommended connection. Both Figures A and B allow the proper power supply to be available to the HRU2-5A to safeguard against freezing as explained below.

OPERATION OF THE HEAT RECOVERY UNIT

The HRU2-5A operation is controlled by a series of four thermostats, on/off switch, and two fuses. Three thermostats are electrically connected to insure a safe hot water supply temperature when a sufficient discharge gas temperature (160°F) is present.

The HRU2-5A water heater is a very simple device having a circulating water pump, a double wall heat exchanger and four thermostats. When the refrigerant temperature in the heat recovery coil reaches 160°F the circulating pump delivers cool water from the water heater tank through the double wall heat exchanger. Heat is transferred from the hot refrigerant to the cool water. A temperature-controlled switch, located on the inlet HRU2-5A water line will stop the circulating pump when the return water temperature reaches 140°F. For outside applications the circulating pump is energized by use of another thermostat if outdoor temperatures approach freezing.

The HRU2-5A is internally fused and is equipped with an on/off disconnect switch.

START UP AND CHECK OUT

Be sure all SHUT OFF valves are open and all power supplies are on.

Open a hot water faucet to permit any air to bleed from the plumbing. In addition, depress the dill valve located between the circulating pump and heat exchanger to bleed air.

Turn ON the air conditioning system and verify the circulating pump will operate. Feel the "WATER IN" and "WATER OUT" tubes for a noticeable difference in temperature. Turn OFF the air conditioning system and verify that the circulating pump stops.

MAINTENANCE

CLEANING THE HEAT EXCHANGER. If scaling of the coil is strongly suspected, the coil can be cleaned with a solution of phosphoric acid (food grade acid). Follow the manufacturer's directions for the proper mixing and use of cleaning agent.

HRU2-5A WIRING INFORMATION

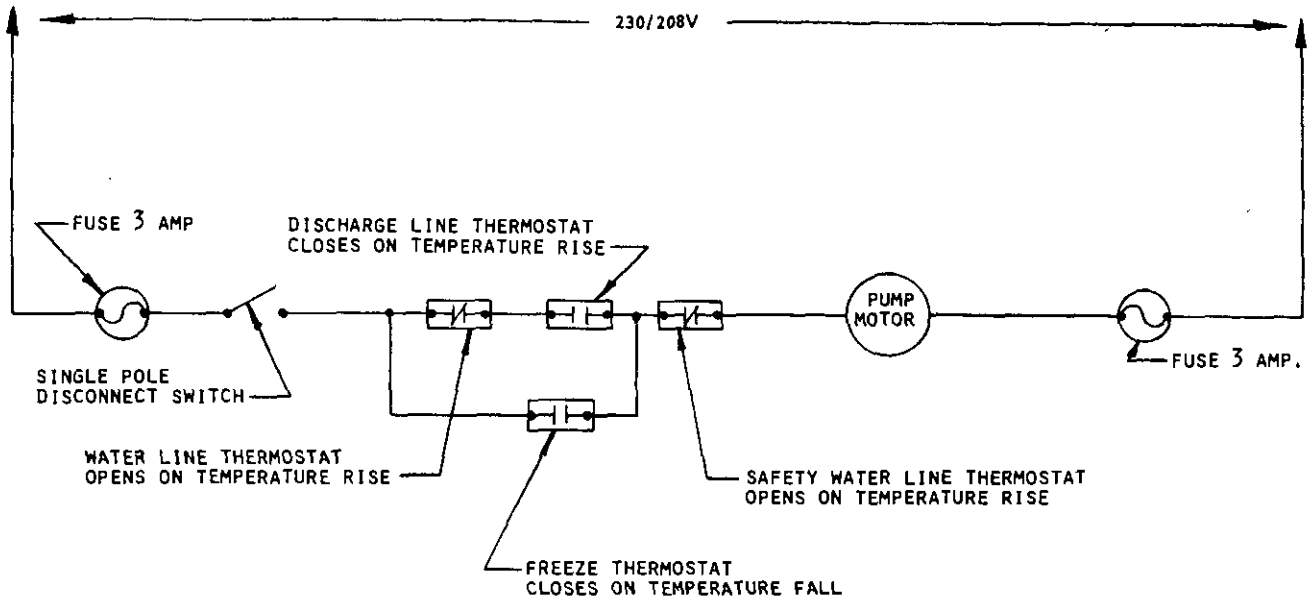

NOTE: All wiring must conform to local codes.

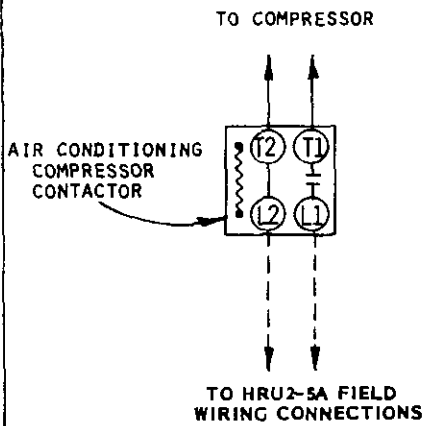

Figure A

TYPICAL AIR CONDITIONER WIRING CONNECTION

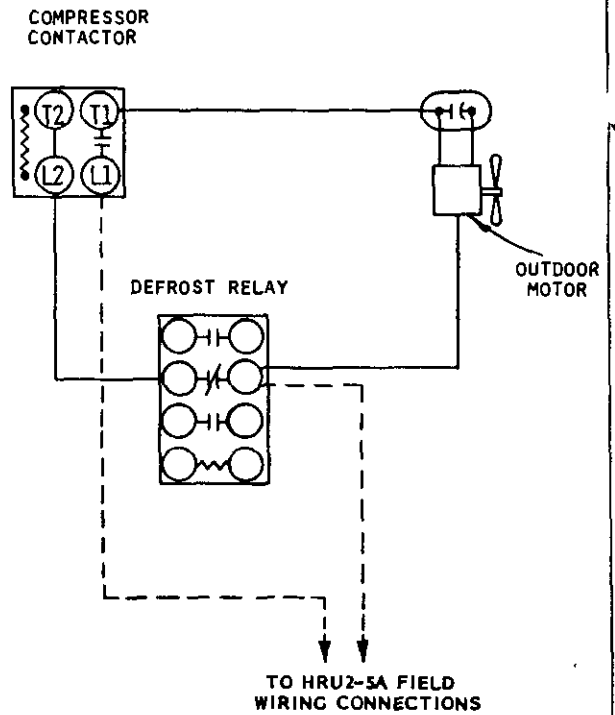

Figure B

TYPICAL HEAT PUMP WIRING CONNECTION

NOTE: Field wire connections for HRU2-5A must be made as shown to allow freeze protection thermostat to operate.

— FACTORY WIRING
 - - - - - FIELD WIRING

MODEL
 HRU2-5A

4053-110B

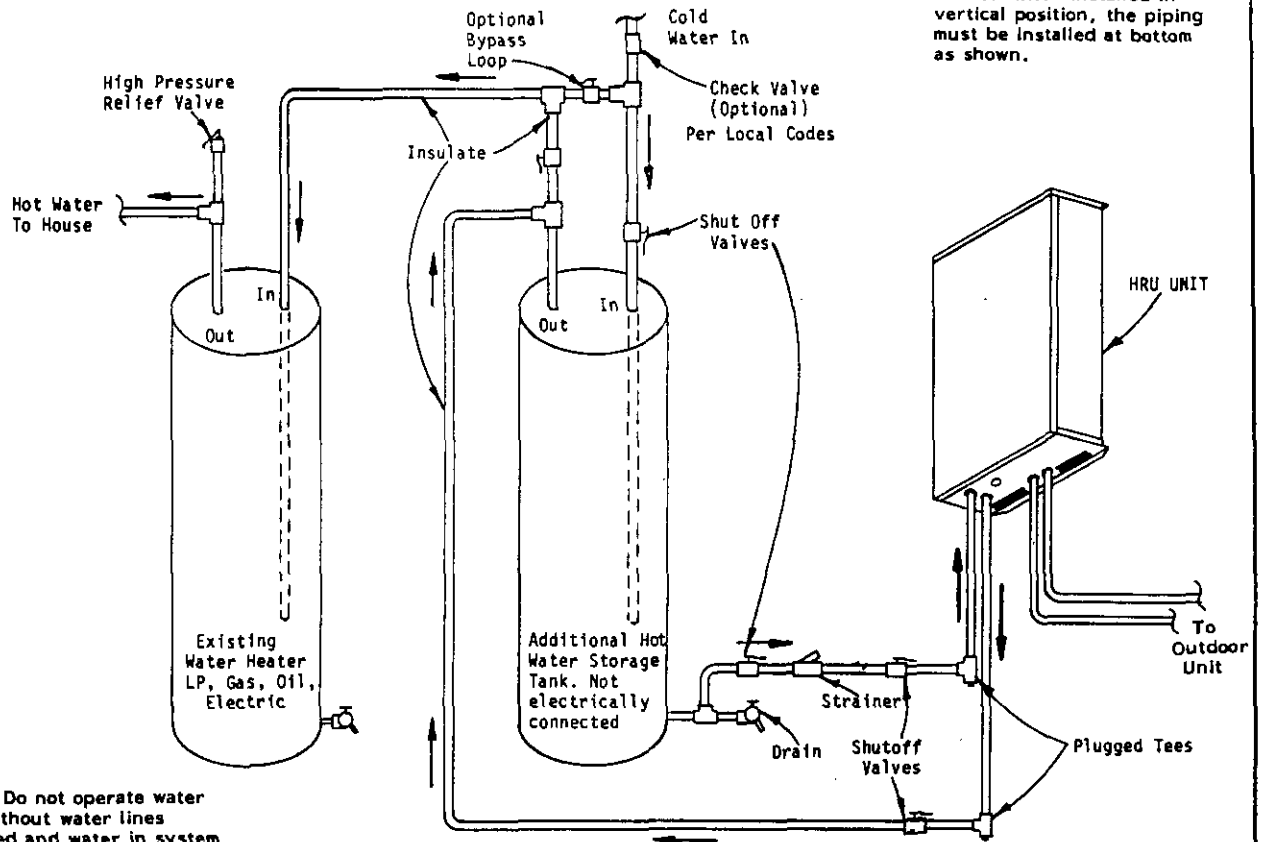

NOTE: When installed in vertical position, the piping must be installed at bottom as shown.

NOTE: Do not operate water pump without water lines connected and water in system with shut off valves open! Turn pump switch to off.

TYPICAL HRU2-5A TWO-TANK INSTALLATION

NOTE: All plumbing must conform to local codes.

(Recommended)

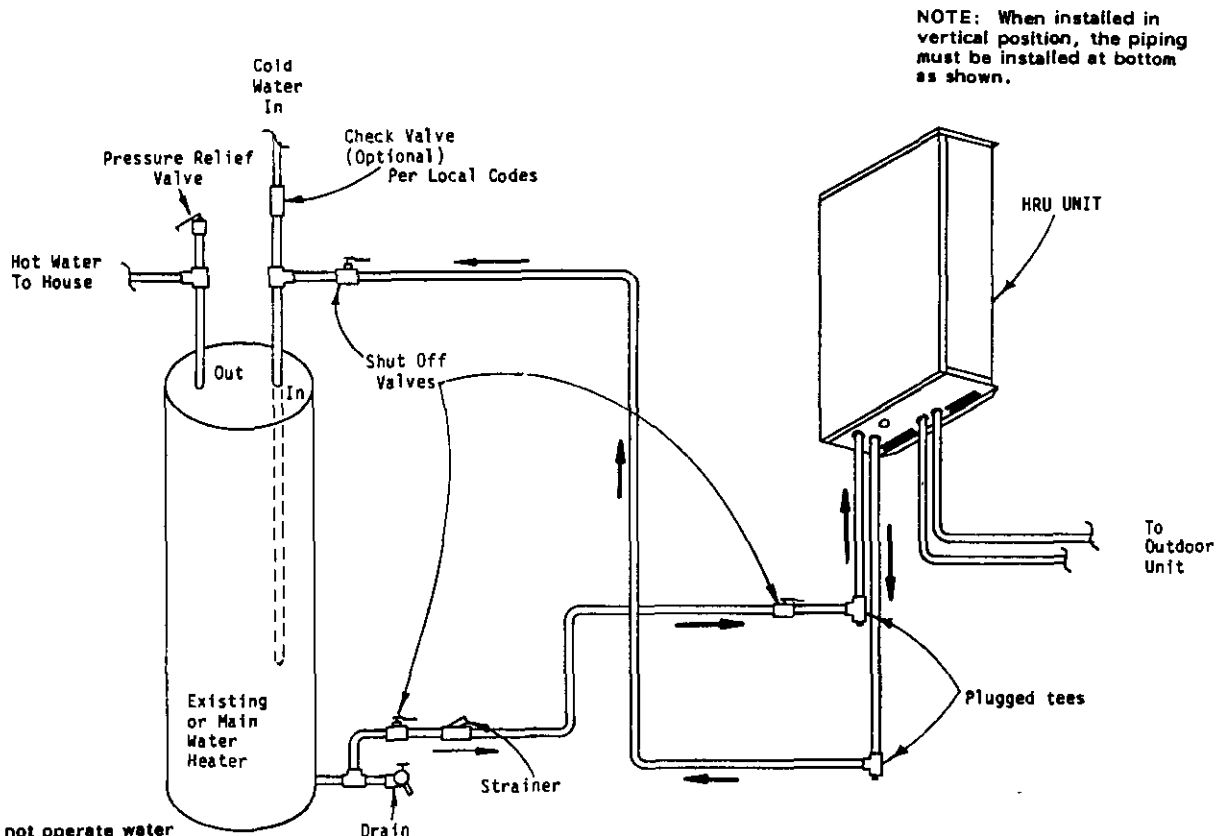

NOTE: When installed in vertical position, the piping must be installed at bottom as shown.

NOTE: Do not operate water pump without water lines connected and water in system with shut off valves open! Turn pump switch to off.

TYPICAL HRU2-5A ONE-TANK INSTALLATION

NOTE: All plumbing must conform to local codes.

(Permissible with electric water heater only)

PARTS LIST
HRU2-5A
HEAT RECOVERY UNIT

2/87

Part No.	Description	HRU2-5A
5052-004	Desuperheater Water Coil	x
8300-001	Water Pump	x
8408-010	Thermostat - Freeze Protection	x
8408-009	Thermostat - Discharge Tube	x
8408-007	Thermostat - Water Line	x
8408-011	Thermostat - Water Line - Safety	x
8406-020	Toggle Switch SPST	x
8614-036	Circuit Breaker	2

Supersedes all previous lists.
Subject to change without notice.