

INSTALLATION INSTRUCTIONS

FSM-1B FUEL SAVER MODULE

COPYRIGHT JUNE, 1989
BARD MANUFACTURING COMPANY
BRYAN, OHIO

INDEX

General	1
What Type of Installations and Fuels Should The Fuel Saver Module Be Used On?	1
Where To Locate The Module	1
Wiring Connections	1
Gas or Oil Furnace Applications	1
1. Thermal Balance Point	1
How to Set The Outdoor Thermostat At The Most Economic Balance Point When Using The Fuel Saver Module	1
1. Economic Balance Point.	1
Sequence of Operation	2
Defrost Cycle	3
Important	3
Wiring Diagram	6

FIGURES AND TABLES

Table 1	4
Table 2	4
Table 3	5
Table 4	5

INSTALLATION INSTRUCTIONS FSM-1B FUEL SAVER MODULE

GENERAL

The Fuel Saver Module is a control package which permits the heat pump to operate below the thermal balance point to maximize the energy savings. For each application, an analysis should be made to determine the economic balance point which is the outdoor temperature at which it becomes more cost effective to shut the heat pump down with an outdoor thermostat. This temperature varies with each combination of fuel cost, furnace efficiency and heat pump efficiency level. Refer to How To Set The Outdoor Thermostat At The Economic Balance Point.

WHAT TYPE OF INSTALLATIONS AND FUELS SHOULD THE FUEL SAVER MODULE BE USED ON?

The module is designed for fuel oil, natural gas and propane gas furnaces.

WHERE TO LOCATE THE MODULE

The module can be located in any indoor dry location between the furnace and the outdoor section. It can be installed in any position most convenient for installation, wiring connections, and service considerations. DO NOT locate the module outside the building.

WIRING CONNECTIONS

All wiring is 24V. An eight (8) wire color coded thermostat cable is recommended. The electrical connection to the module is quite easy. Simply cut the thermostat cable, with the wires coming from the furnace connected to the terminal block designated "FURNACE CONNECTIONS," and the wires from the heat pump to terminal block designated "HEAT PUMP CONNECTIONS." Refer to wiring diagram for complete details.

GAS OR OIL FURNACE APPLICATION

THERMAL BALANCE POINT--The point at which the heat pump output capacity and the heat loss from the building being heated are equal is called the balance point, with the heat pump operating 100 percent of the time. As the outdoor temperature goes down, the BTU capacity of the heat pump falls off while at the same time the heat loss from the structure increases. A means of placing the fossil fueled furnace in operation at outdoor temperatures below the balance point must be provided. In all instances, the gas or oil furnace must be of sufficient capacity to heat the building even under the most extreme outdoor temperature, without the aid of the heat pump.

There is no one given outdoor temperature at which the balance point will occur, it will be different for each application of heat pump to a building, and can even vary from day to day based upon cloud cover, relative humidity outdoors, and wind conditions. Of course, the design of the building (insulation, types of windows, doors, etc., and other items that affect the heat loss) also determine where the balance point will occur for a given size heat pump system.

The Fuel Saver Module in conjunction with the wall thermostat will automatically sense and respond to all of the variable factors that influence the heating requirements for any given structure.

HOW TO SET THE OUTDOOR THERMOSTAT AT THE MOST ECONOMIC BALANCE POINT WHEN USING THE FUEL SAVER MODULE

ECONOMIC BALANCE POINT--There is an "economic balance point" or "break even point" which can be calculated for all situations based upon actual energy rates for the various fuels and the efficiency ratings of the add-on heat pump and the furnace involved.

Depending upon the local electrical rates and the cost of the other fuel involved, the use of an outdoor thermostat may be desirable to control the changeover from heat pump to furnace at the most cost effective outdoor temperature. The procedure to make this determination is quite simple and outlined below. The tables referenced are located later in this manual, and the same information is also shown in the Fuel Saver Module Installation Instructions. To determine the economic balance point using a module, do the following steps:

- A. Locate the table for fossil fuel used by furnace. (Table 1--Natural Gas; Table 2--Propane; and Table 3--Fuel Oil)
- B. Now locate the furnace AFUE efficiency rating for the furnace on the bottom of table the heat pump is being matched with.
- C. Next draw a line straight up until it intersects the fuel unit cost curve for the fuel in your area. (Fuel unit cost scale on right side of table.)
- D. Then draw a horizontal line from the intersection point to the BTUH per \$1.00 column on left side of table. You now have determined the BTUH output of heating per one dollar of energy cost for that fuel.

Example 1 (Table 3):

An oil furnace with a 65 percent AFUE efficiency at \$1.30 per gallon would equal 70,000 BTUH per dollar of energy (oil) cost.

- E. Now go to Table 4 (air source or water source heat pump) and locate the BTUH per dollar (step D above) on left side of table. Draw a horizontal line from the BTUH per \$1.00 until it intersects the cost per KW in your locality.
- F. Then draw a vertical line down to the heat pump COP (Coefficient of Performance) scale at bottom of table. You now have found the lowest COP at which the heat pump should be operated economically.

Example 2 (Table 3):

A 65 percent AFUE efficient oil furnace will supply 70,000 BTUH per dollar of fuel cost, at a fuel cost of \$1.30 per gallon. A heat pump also will produce 70,000 BTUH output per dollar at an electric rate of \$.06 per kw. The heat pump will produce this at a COP of 1.21.

- G. Refer to the "Heating Application Data" section of the heat pump specification sheet to determine at what outdoor temperature the heat pump will produce a 1.21 COP. This temperature is the "Economic Balance Point" at which the outdoor temperature is set at to shut the heat pump off and operate entirely on the furnace.
- H. Now set the outdoor thermostat to turn off the compressor at the "Economic Balance Point" temperature determined in (step G) above.

SEQUENCE OF OPERATION

- A. Fan AUTO-ON function and operation in cooling mode remain the same as in any air conditioning or heat pump system.
- B. When in heating mode, each initial call for heat will place heat pump in operation.
- C. If the heat pump cannot handle the heating requirements of the structure during any given cycle, the space temperature will begin to drop. If it drops approximately 1-1/2 degree F, the second stage of the wall thermostat will activate the module, turning off the heat pump and starting the furnace.
- D. The furnace will continue to operate, suppling heat until the wall thermostat (both stages 1 and 2) are

satisfied. When the thermostat is satisfied, the module resets, and the next call for heat will start over with heat pump operating as the primary heating system and the furnace on standby as described above.

- E. The module allows for activation of the furnace during the defrost cycle of the heat pump "if desired." It is usually desirable to provide this supplemental heat during the brief defrost cycle period to avoid discharging cool air into the building. A complete discussion on this subject can be found in the installation instructions packaged with the Add-On Heat Pump Coil. Connection of a single 24V wire at the module will allow the furnace to cycle on during the defrost cycle. Refer to wiring diagram.
- F. "Emergency Heat" function is available on command from the wall thermostat. This locks out the heat pump from operating under any condition and allows furnace operation only. Only during "Emergency Heat" operation is the heating system under control of the second stage of wall thermostat and in this mode of operation structure is controlled at 1-1/2 degree F below thermostat setpoint. IMPORTANT: Only in emergency heat mode does furnace blower operate from combination fan/limit switch in furnace. In all other modes, the furnace blower is controlled by the call for heat or cool operation. There is additional information on "Indoor Blower Operation" contained in the installation instructions for the add-on heat pump coil.
- G. Any time the wall thermostat is set for heating and a large change to a higher temperature setting is made, or the system is turned on after being off and the actual space temperature is lower than the thermostat setpoint, the second stage will be closed (calling for heat) and the control system will lock out the heat pump and activate the furnace until the desired space temperature is reached. At that time, the control system will reset and the next call for heat will again be heat pump.

DEFROST CYCLE

Heat pumps operating during outdoor temperatures below the low 40 degree F range and colder will gradually accumulate a frost build-up on the outdoor coil. A defrost cycle control system is built into all outdoor heat pump sections that will periodically and automatically clear the outdoor coil of this frost accumulation. This is accomplished by the heat pump system temporarily reverting back to the cooling cycle, using the hot refrigeration gas flowing through the outdoor coil to melt the frost. The outdoor fan motor also stops during this period to speed up the process. During this time of defrost cycle operation, there will be a cooling affect taking place at the indoor coil section the same as would occur during the summer cooling system.

It is desirable to supply supplemental heat during the defrost cycle period, so as to avoid the discharging of cool air into the building. Laboratory and field testing has shown that firing of the gas or oil furnace during the defrost cycle is permissible and can in fact even shorten the time required for defrosting the outdoor coil because of the introduction of heat immediately ahead of the outdoor coil assembly.

IMPORTANT:

Since the size of the fossil furnace is known only to the installer of the system, it is possible that there would be an excessively large BTU capacity furnace involved, especially in an add-on situation (it is not uncommon for some fossil fueled furnaces, especially oil-fired, to be vastly oversized). Should this instance be encountered, it is possible that because of the furnace BTU output involved, an excessively fast temperature rise air temperature entering the refrigerant coil mounted on the furnace may result in higher discharge pressure and temperature than the compressor protective devices will tolerate and cause tripping of these protective devices.

It is the responsibility of the installer to understand this operation of the system in detail, and should this occur, set the temperature of the changeover thermostat to a higher temperature. This will lessen the amount of frost accumulation, shorten the length of the actual defrost cycles and thus the time of simultaneous operation of heat pump and furnace.

An alternative to this is not to allow the furnace to cycle "on" during the defrost period. The Fuel Saver Module wiring diagram shows which 24V wiring connection is not to be made to defeat the supplemental heat during defrost.

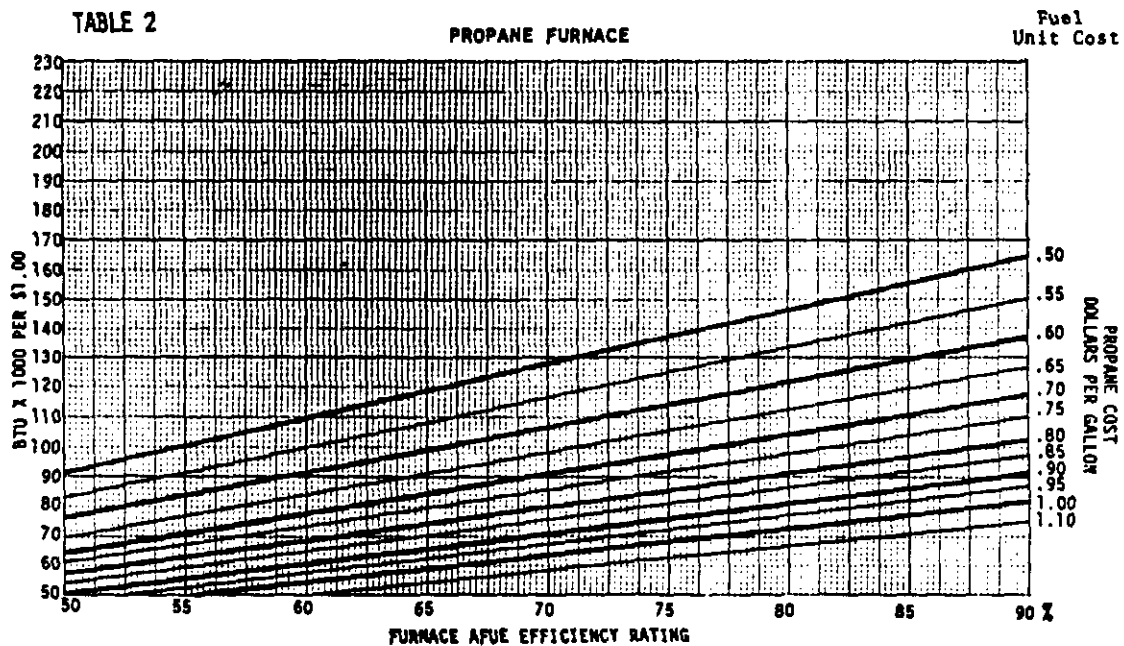
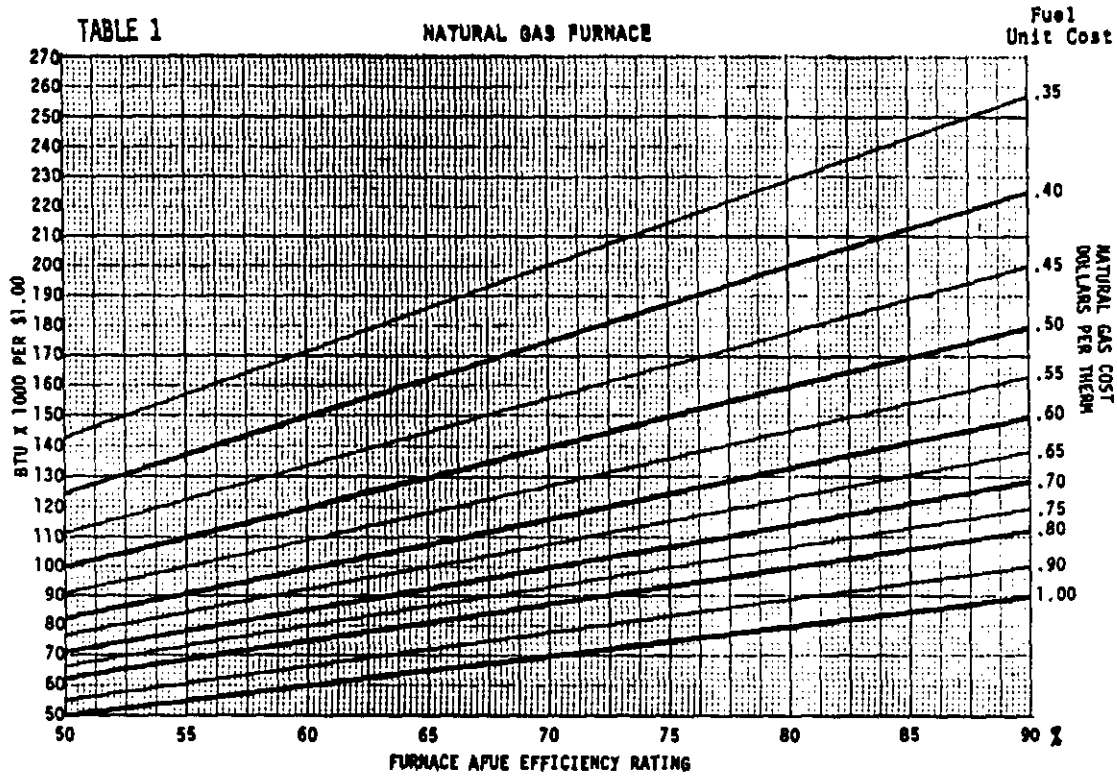

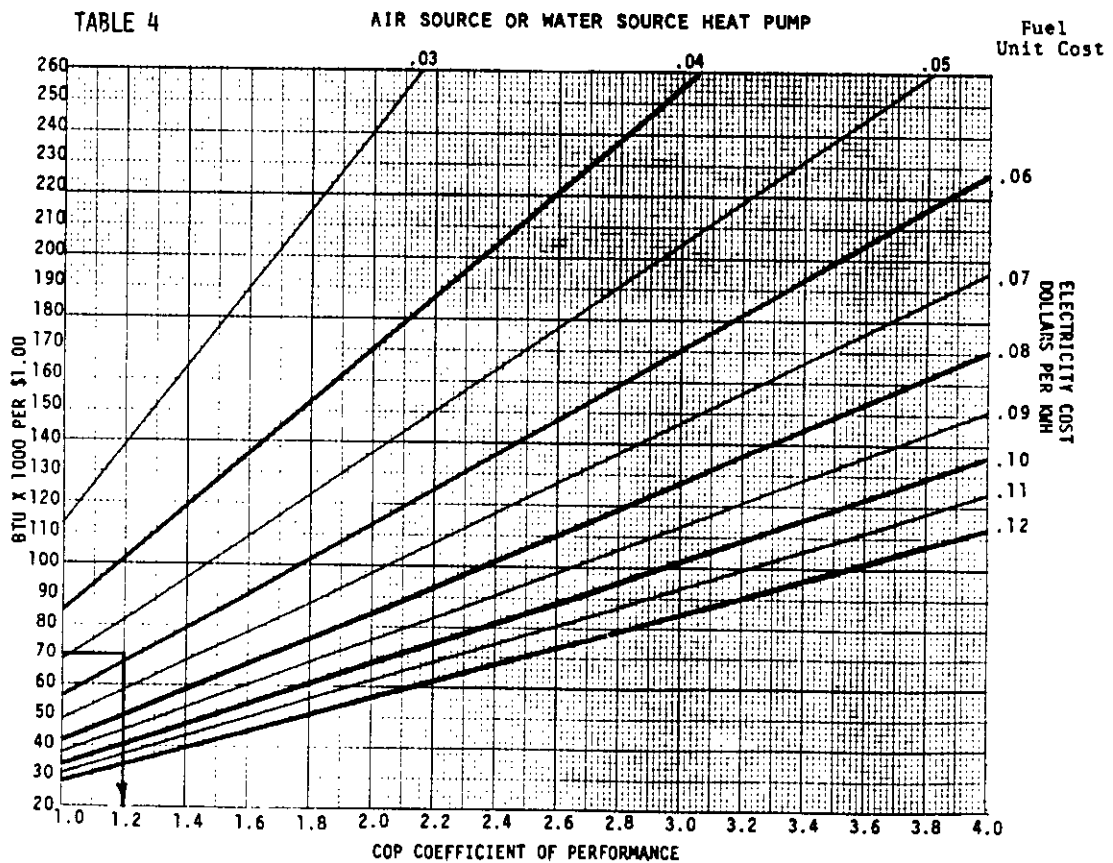
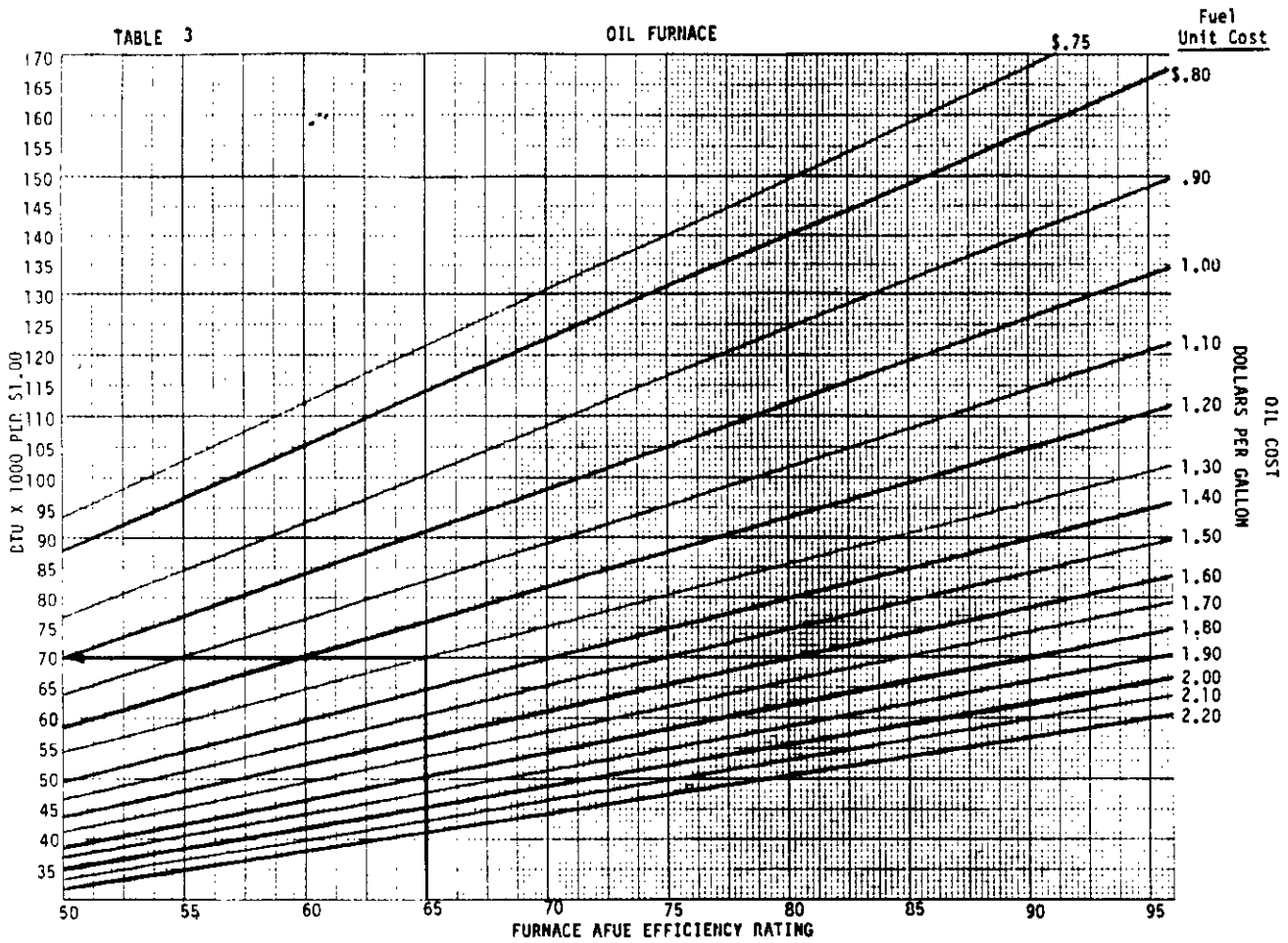

Example 2. Determine Economic Balance Point for Heat Pump when used with an oil furnace of 65% AFUE @ \$1.30 per gallon for oil from example 1 (oil furnace 70,000 Btuh/\$) and electric rate of .06 kWh. A 1.21 COP, heat pump and oil is equal in operating cost.

FUEL SAVER MODULE
PART # FSB-18
MUST BE INSTALLED
INDOORS

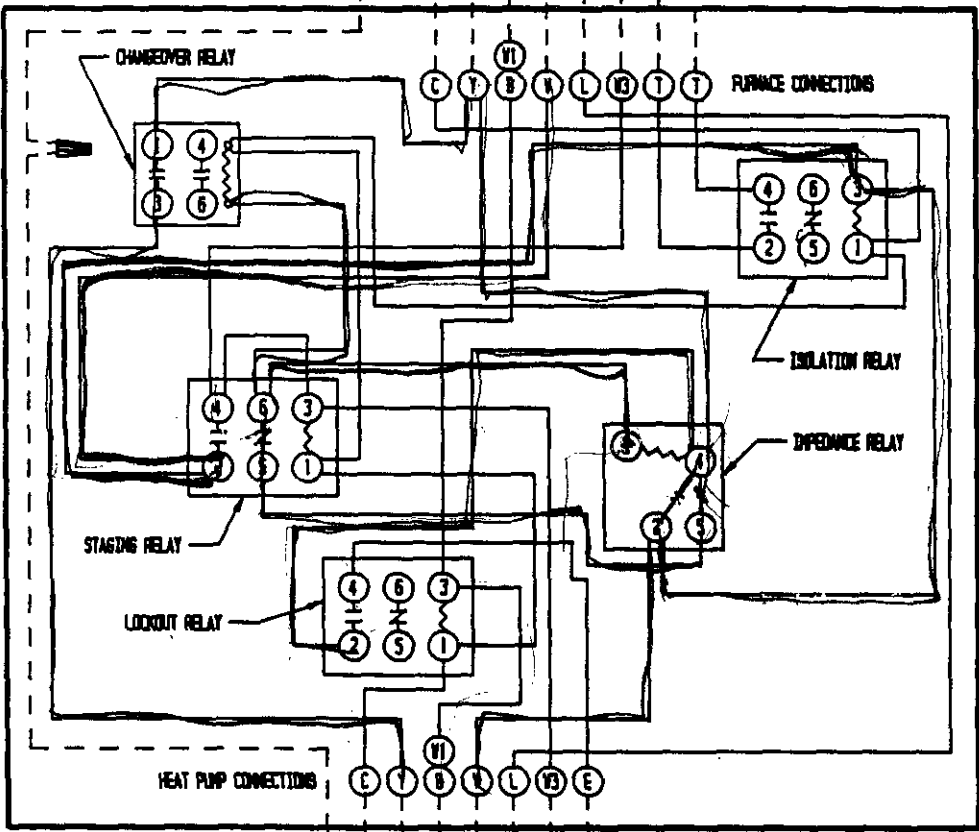
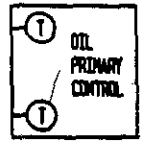
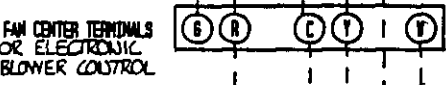

THESE WIRES REQUIRED
ONLY IF OPTIONAL
OUTDOOR THERMOSTAT
IS USED

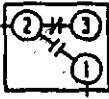

OPTIONAL 03T-070
OUTDOOR THERMOSTAT
RANGE 0° - +70°.
USED AS LOW AMBIENT
CUT OFF OR ECONOMIC
BALANCE POINT CONTROL

MAKE (OH) CONNECTION ONLY IF
DESTINED TO OPERATE THE FURNACE
DURING DEFFROST CYCLE