

# **INSTALLATION INSTRUCTIONS**

## **FSM-1B FUEL SAVER MODULE**

## INSTALLATION INSTRUCTIONS FSM-1B FUEL SAVER MODULE

### GENERAL

The Fuel Saver Module is a control package which permits the heat pump to operate below the thermal balance point to maximize the energy savings. For each application, an analysis should be made to determine the economic balance point which is the outdoor temperature at which it becomes more cost effective to shut the heat pump down with an outdoor thermostat. This temperature varies with each combination of fuel cost, furnace efficiency and heat pump efficiency level. Refer to Section 5, How To Set The Outdoor Thermostat At The Economic Balance Point.

### WHAT TYPE OF INSTALLATIONS AND FUELS SHOULD THE FUEL SAVER MODULE BE USED ON?

The module is designed for fuel oil, natural gas and propane gas furnaces.

### WHERE TO LOCATE THE MODULE

The module can be located in any indoor dry location between the furnace and the outdoor section. It can be installed in any position most convenient for installation, wiring connections, and service considerations. DO NOT locate the module outside the building.

### WIRING CONNECTIONS

All wiring is 24V. An eight (8) wire color coded thermostat cable is recommended. The electrical connection to the module is quite easy. Simply cut the thermostat cable, with the wires coming from the furnace connected to the terminal block designated "FURNACE CONNECTIONS," and the wires from the heat pump to terminal block designated "HEAT PUMP CONNECTIONS." Refer to wiring diagram for complete details.

### HOW TO SET THE OUTDOOR THERMOSTAT AT THE MOST ECONOMIC BALANCE POINT WHEN USING THE FUEL SAVER MODULE

To determine the economic balance point using a module, do the following steps:

- A. Locate the table for fossil fuel used by furnace. (Table 1--Natural Gas; Table 2--Propane, and Table 3--Fuel Oil).
- B. Now locate the furnace AFUE efficiency rating for the furnace on the bottom of table the heat pump is being matched with.
- C. Next draw a line straight up, until it intersects the fuel unit cost curve for the fuel in your area. (Fuel unit cost scale on right side of table.)
- D. Then draw a horizontal line from the intersection point to the BTUH per \$1.00 column on left side of table. You now have determined the BTUH output of heating per one dollar of energy cost for that fuel.

Example 1: (Table 3)

An oil furnace with a 65 percent AFUE efficiency @ \$1.30 per gallon would equal 70,000 BTUH per dollar of energy (oil) cost.

- E. Now go to Table 4 (air source or water source heat pump) and locate the BTUH per dollar (Step D above) on left side of table. Draw a horizontal line from the BTUH per \$1.00 until it intersects the cost per KWH in your locality.

- F. Then draw a vertical line down to the heat pump COP (Coefficient of Performance) scale on bottom of table. You now have found the lowest COP at which the heat pump should be operated economically.

Example 2: (Table 4)

A 65 percent AFUE efficient oil furnace will supply 70,000 BTUH per dollar of fuel cost, at a fuel cost of \$1.30 per gallon. A heat pump also will produce 70,000 BTUH output per dollar at an electric rate of \$.06 per KW. The heat pump will produce this at a COP of 1.21.

- G. Refer to the "Heating Application Data" section of the heat pump specification sheet to determine at what outdoor temperature the heat pump will produce a 1.21 COP. This temperature is the "Economic Balance Point" at which the outdoor thermostat is set at to shut the heat pump off and operate entirely on the furnace.
- H. Now set the outdoor thermostat to turn off the compressor at the "Economic Balance Point" temperature determined in (Step G) above.

### SEQUENCE OF OPERATION

- A. Fan AUTO-ON function and operation in cooling mode remain the same as in any air conditioning or heat pump system.
- B. When in heating mode, each initial call for heat will place heat pump in operation.
- C. If the heat pump cannot handle the heating requirements of the structure during any given cycle, the space temperature will begin to drop. If it drops approximately 1-1/2 degree F, the second stage of the wall thermostat will activate the module, turning off the heat pump and starting the furnace.
- D. The furnace will continue to operate, supplying heat until the wall thermostat (both stages 1 and 2) are satisfied. When the thermostat is satisfied, the module resets, and the next call for heat will start over with heat pump operating as the primary heating system and the furnace on standby as described above.
- E. The module allows for activation of the furnace during the defrost cycle of the heat pump "if desired." It is usually desirable to provide this supplemental heat during the brief defrost cycle period to avoid discharging cool air into the building. A complete discussion on this subject can be found in the installation instructions packaged with the Add-On Heat Pump Coil. Connection of a single 24V wire at the module will allow the furnace to cycle on during the defrost cycle. Refer to wiring diagram.
- F. "Emergency Heat" function is available on command from the wall thermostat. This locks out the heat pump from operating under any condition and allows furnace operation only. Only during "Emergency Heat" operation is the heating system under control of the second stage of wall thermostat and in this mode of operation structure is controlled at 1-1/2 degree F below thermostat setpoint. IMPORTANT: Only in emergency heat mode does furnace blower operate from combination fan/limit switch in furnace. In all other modes, the furnace blower is controlled by the call for heat or cool operation. There is additional information on "Indoor Blower Operation" contained in the installation instructions for the add-on heat pump coil.
- G. Any time the wall thermostat is set for heating and a large change to a higher temperature setting is made, or the system is turned on after being off and the actual space temperature is lower than the thermostat setpoint, the second stage will be closed (calling for heat) and the control system will lock out the heat pump and activate the furnace until the desired space temperature is reached. At that time, the control system will reset and the next call for heat will again be heat pump.

TABLE 1

NATURAL GAS FURNACE

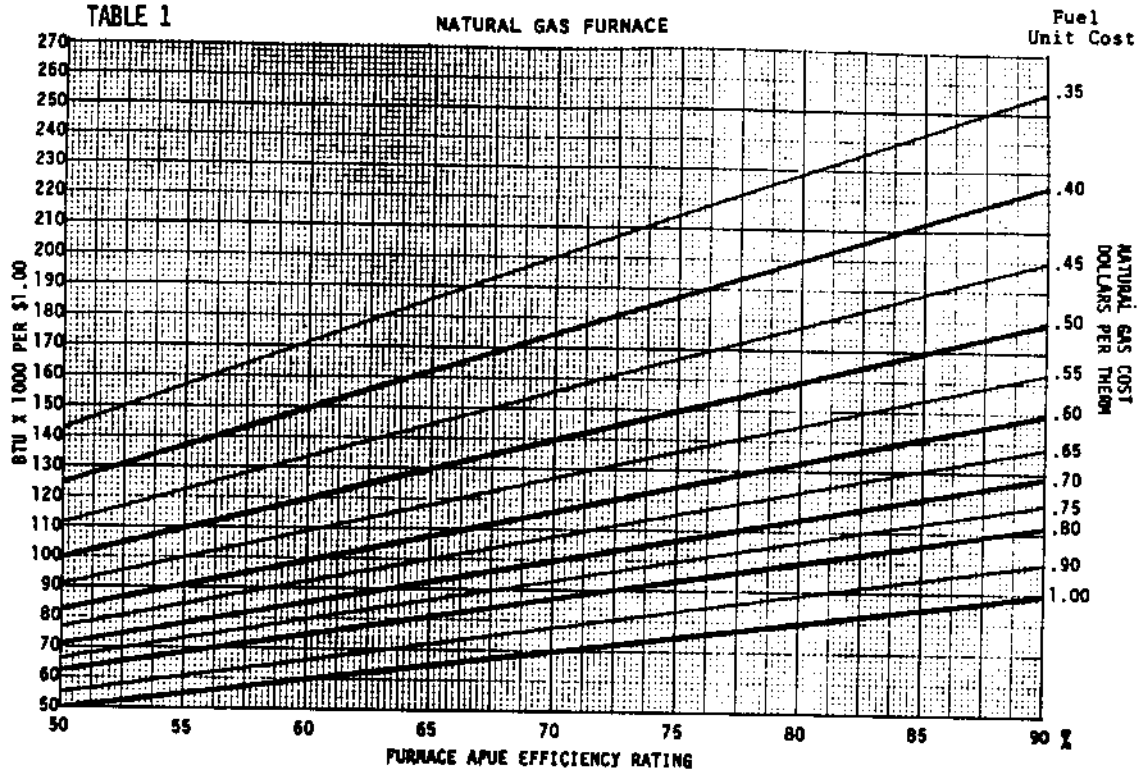

TABLE 2

PROPANE FURNACE

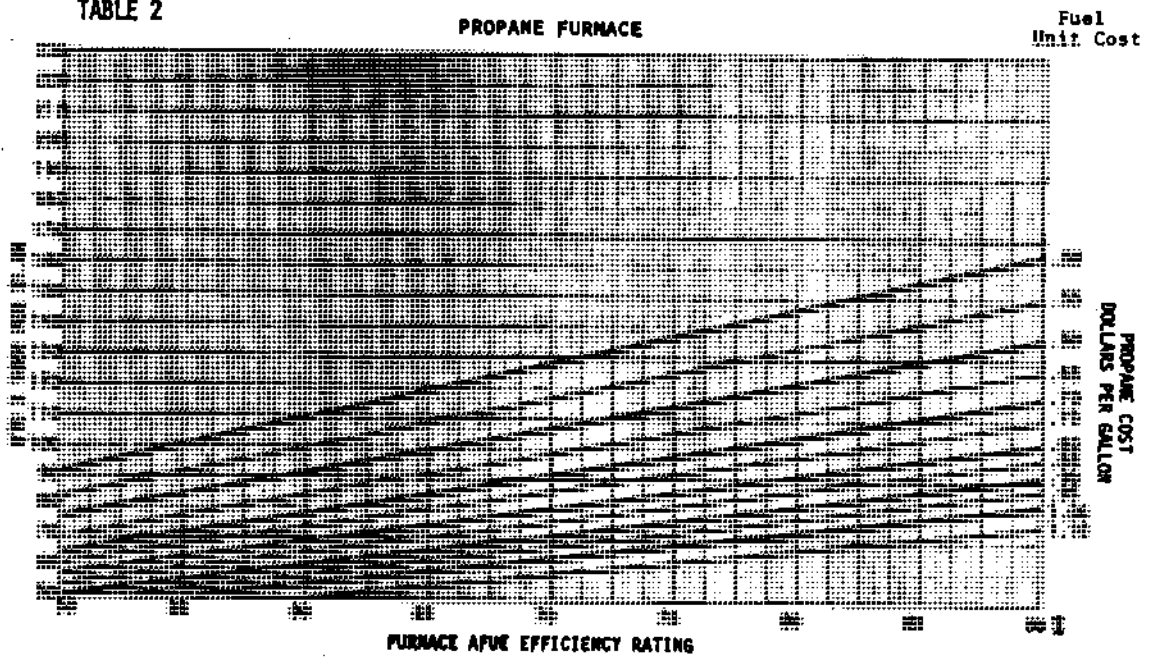
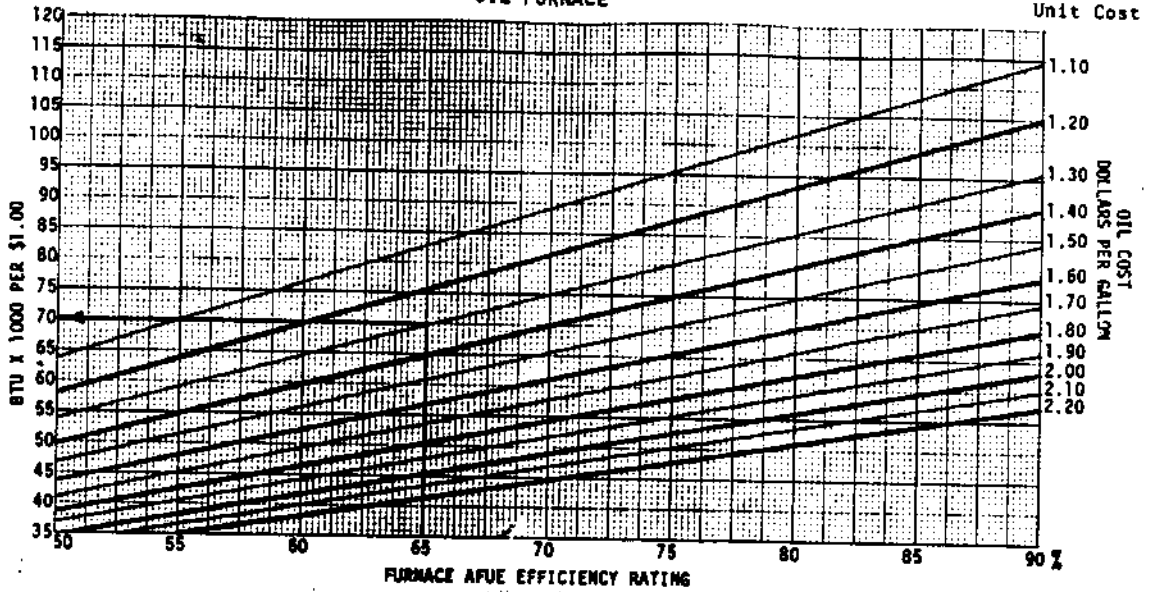

TABLE 3

OIL FURNACE



Example 1. Assume a 65% AFUE oil furnace at \$1.30 per gallon.

TABLE 4

AIR SOURCE OR WATER SOURCE HEAT PUMP

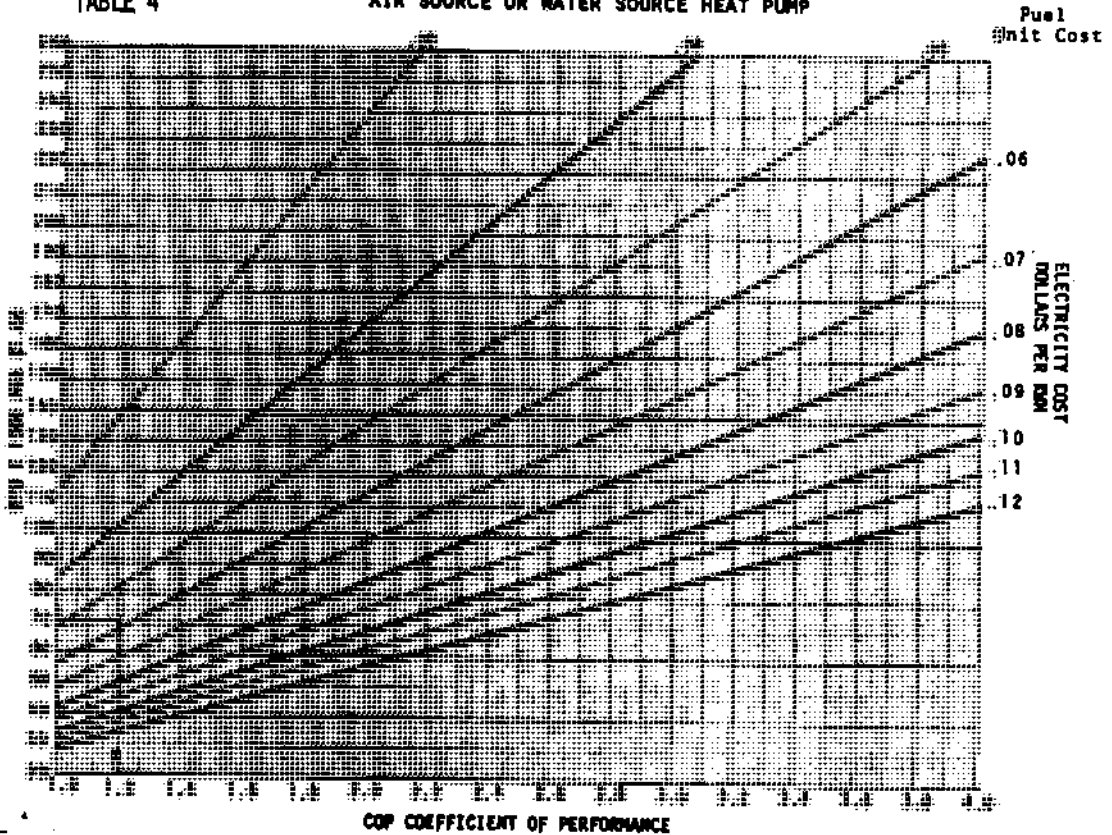

Example 2. Determine Economic Balance Point for Heat Pump when used with an oil furnace of 65% AFUE @ \$1.30 per gallon for oil from example 1 (oil furnace 70,000 Btu/h) and electric rate of .06 kWh. A 1.21 COP, heat pump and oil is equal in operating cost.

FUEL SAVER MODULE  
PART # FSH-18  
MUST BE INSTALLED  
INDOORS

T874N1024/057F1251



T874R1125/057AL1101  
OR  
IF58-45

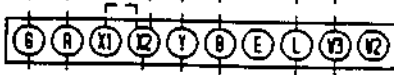

FAN CENTER TERMINALS

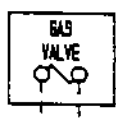

ON ELECTRIC IGNITION MODELS,  
CONNECT WIRE FROM "V" TO  
THE BLACK WIRE FROM  
MATING PLUG FOR  
OPTIONAL FLUE  
DAMPER

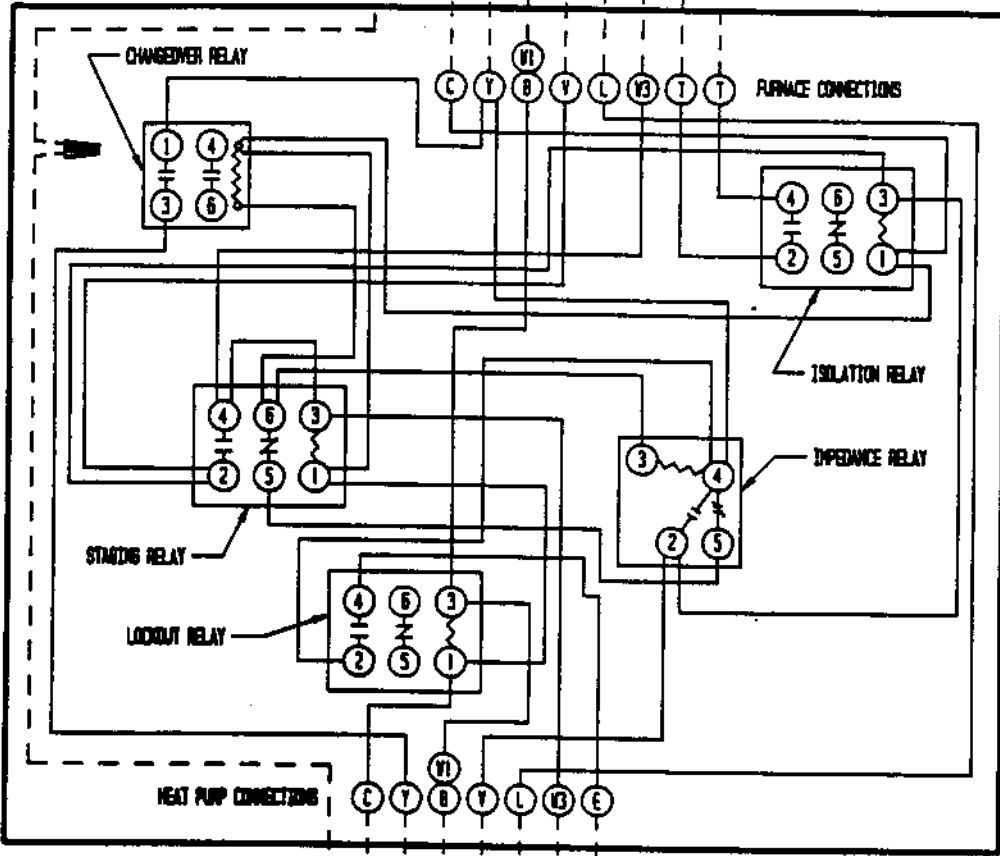
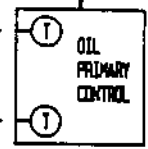

18 - 35 HPQ MODELS  
24V TERMINAL STRIP



24 - 35 HPQ MODELS  
24V TERMINAL STRIP



42 - 60 HPQ MODELS  
24V TERMINAL STRIP



THESE WIRES REQUIRED  
ONLY IF OPTIONAL  
OUTDOOR THERMOSTAT  
IS USED

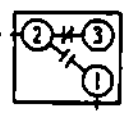

OPTIONAL ODT-070  
OUTDOOR THERMOSTAT  
RANGE 0° - +70°.  
USED AS LOW AMBIENT  
CUT OFF OR ECONOMIC  
BALANCE POINT CONTROL.

MAKE (DN) CONNECTION ONLY IF  
DESIRED TO OPERATE THE FURNACE  
DURING DEFOST CYCLE