

**MODELS  
B18EHQ1-B24EHQ1-B30EHQ  
BLOWER COIL UNIT**

**INSTALLATION INSTRUCTIONS**

**FOR RESIDENTIAL AND COMMERCIAL  
HEATING/COOLING APPLICATIONS**

**MOUNTING POSITIONS AND RETURN AIR OPTIONS**

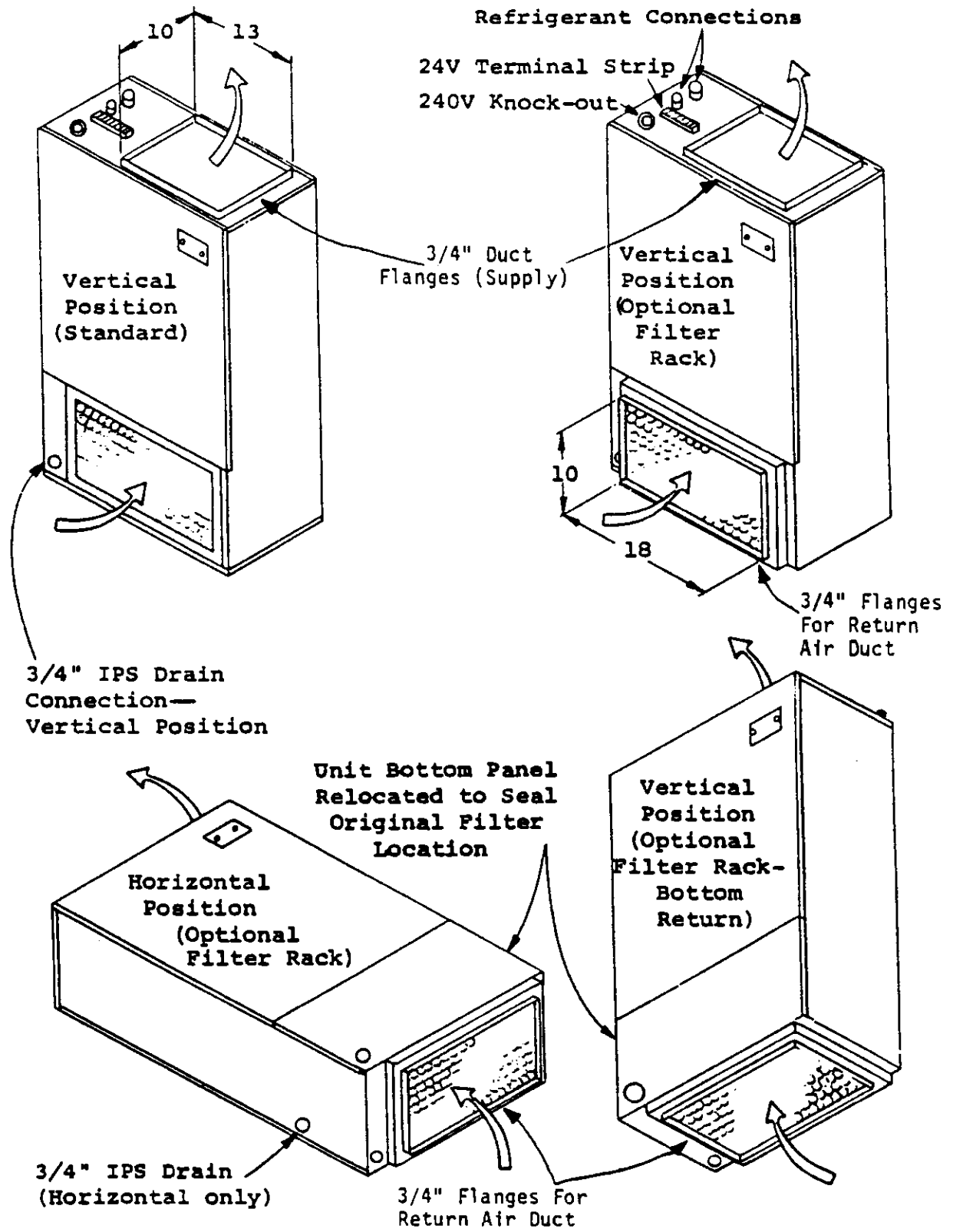

NOTE: If no return air duct is used, applicable installation codes may limit this cabinet to installation only in a single story structure.

**GENERAL**

Units are shipped completely assembled and internally wired, requiring only duct connections, thermostat wiring and external 220-240 volt AC power supply.

15Kw models require an external fuse panel, Model RFP-15, to comply with installation requirements. Refer to "Electrical Specifications" and "Field Wiring Data" for complete information. The approved matching combinations of indoor and outdoor sections are:

Type	Indoor Section	Outdoor Section
A/C	B18EHQ1	18ECQ2
A/C	B24EHQ1	18ECQ2
A/C	B18EHQ1	24ECQ4
A/C	B24EHQ1	24ECQ4
A/C	B24EHQ1	24UACQ,S-A
A/C	B30EHQ	30ECQ4
A/C	B30EHQ	31ECQ2
H/P	B18EHQ1	18HPQ5
H/P	B24EHQ1	18HPQ5
H/P	B18EHQ1	24HPQ5
H/P	B24EHQ1	24HPQ5
H/P	B30EHQ	30HPQ6

Upon receipt of equipment, carton should be checked for external signs of damage. If damage is found, request for inspection by carrier's agent should be made in writing immediately.

**INSTALLATION**

Size of unit for a proposed installation should be based on heat loss calculation made according to methods of Air Conditioning Contractors Association. The air duct should be installed in accordance with the Standards of the National Fire Protection Association for the Installation of Air Conditioning and Ventilating Systems of Other Than Residence Type, NFPA No. 90A, and Residence Type Warm Air Heating and Air Conditioning Systems, NFPA No. 90B. Where local regulations are at a variance with instructions, installer should adhere to local codes.

**DUCTWORK**

Design the ductwork according to methods given by the National Warm Air Heating and Air Conditioning Association. When duct runs through unheated spaces, it should be insulated with a minimum of two inches of insulation. Use insulation with a vapor barrier on the outside of the insulation. Flexible joints should be used to connect the ductwork to the equipment in order to keep the noise transmission to a minimum.

**FILTER**

This unit must not be operated without a filter. It comes equipped with a disposable 12x20x1 filter installed for free return application. An optional 12x20 filter rack is available for ducted return applications and can be used for both vertical and horizontal installations.

**LOCATION AND CLEARANCES**

Capacity and efficiency ratings are certified in the vertical installation position. Capacity may be reduced slightly for other installation positions. All access to the equipment is from one side, and at least 24 inches should be provided from this side for service access.

Unit casing is suitable for 0 inch clearance. The first two (2) feet of ductwork attached to the outlet (supply air) connections of the unit are to have a minimum of 1 inch clearance, with 0 inch clearance for any remaining ductwork.

Unit may be installed in utility room, closet, basement, attic, or closed crawl space in either upflow or horizontal position.

When installed horizontal in an attic installation, a platform should be made for the unit to sit on. This platform can be made from 3/4 inch plywood or boards. An auxiliary drain pan should always be used when equipment is installed over a finished living area, to provide protection from water damage in case of plugging of the primary drain line from the unit condensate collection pan.

Secure four pieces of cork or live rubber, 4" x 4", of sufficient thickness to allow primary drain to clear edge of auxiliary drain pan, under each corner of the unit.

**CONDENSATE DRAIN**

Determine where the drain line will run. This drain line contains cold water and must be insulated to avoid drops of water from dripping on ceiling, etc. A trap must be installed in the primary drain line below the bottom of the drain pan.

There is a separate drain connection for vertical and horizontal applications. Refer to drawings on page 2 for locations.

For horizontal installations with auxiliary drain pan, a separate drain line should be run from the auxiliary drain pan and terminated where the homeowner can see it. Be certain to show the homeowner the location of the drain line and to explain its purpose. In the event of overflow of primary drain, water will collect in auxiliary pan and run out through the auxiliary drain line.

It is not recommended that any condensate drain lines be connected to a sewer main. Drain lines must be installed in accordance with local codes.

**INTERCONNECTING TUBING**

It is recommended that the interconnecting tubing be the RW-series charged tubing sets. This is a precharged tubing set with an insulated suction line. Both suction and liquid line are equipped with the correct quick connect fittings for proper match-up to the indoor and outdoor sections. The RW-series is available in standard tubing lengths of 15, 25, 35 and 45 feet.

**THERMOSTAT LOW-VOLTAGE WIRING**

A 24V terminal block is mounted on the top (vertical position) of the unit. There is also a 24V terminal block located in the outdoor section of remote heat pumps and two tagged 24V wires in the outdoor section of remote air conditioners.

Specific control circuit wiring diagrams for the various applications are referenced in the sections titled "AIR CONDITIONING WITH ELECTRIC HEAT" and "HEAT PUMP WITH ELECTRIC HEAT." These diagrams detail the recommended controls and wiring to allow the best possible operation of the different types of systems with respect to energy conservation while still maintaining close comfort levels for the occupant.

**TWO SPEED BLOWER MOTOR**

The BLOWER COIL is supplied with a multiple speed blower motor, using two speed taps to provide airflow variation for the different basic capacity ratings of the outdoor sections.

MOTOR SPEED IDENTIFICATION		
Common	-	Yellow
High	-	Black
Low	-	Red
Capacitor	-	Brown

The HEATING-COOLING BLOWER RELAY provides for single blower speed operation of the motor. A manual changeover can be made by changing the motor speed tap that is connected to the blower relay.

All unused speed taps must be taped securely and individually from one another so as not to short out the motor. Refer to unit wiring diagram for correct identification of relay terminals.

All models are shipped wired on high speed. Refer to "Blower Performance Data" for information on airflow capabilities at different speeds and external static pressures.

FIELD WIRING DATA												
Model	KW	No. of Circuits	Ampacity		Power Wiring				Ground			
			Ckt. A	Ckt. B	Ckt. A		Ckt. B		Ckt. A		Ckt. B	
					CU	AL	CU	AL	CU	AL	CU	AL
All	0 5 10 15	1 1 1 2*	15 28 54 54*	26*	14 10 6 6	12 8 4 4	10	8	14 10 10 10	12 8 8 8	10	8

\*Two (2) circuits with ampacities as shown required between blower coil unit and RFP-15 Remote Fuse Panel. Single circuit ampacity input to RFP-15 is 80. Recommended power wiring is #3 CU or #1 AL, and ground wire #8 CU or #6 AL.

BLOWER COIL ELECTRICAL SPECIFICATIONS						
Model	Rated KW	Amps*	Ampacity		Main Fuse	
			Ckt. A	Ckt. B	Ckt. A	Ckt. B
All	0 5 10 15	1.7 22.5 43.3 64.1	15 28 54 54**	26**	15 30 60 80***	

\*Total unit amps including blower motor.  
\*\*See above note for Field Wiring Data.  
\*\*\*Main fuse applying RFP-15. Internal fuses of RFP-15 are 60A and 30A.

#### UNIT OPERATION

The controls in these blower coil units provide for manual/auto operation of the blower motor in addition to the staging of the installed electric heat. Staging is accomplished in basic 10Kw increments, that is, each heat contactor controls up to two 5Kw elements.

HEATER ELEMENT STAGING		
Model	Heater Kw	Stages
B18EHQ1 B24EHQ1	5 or 10 15	1 2
B30EHQ	5 10 or 15	1 2

Heater stage designations are as follows on the 24V terminal blocks:

Models B18EHQ1, B24EHQ1, B30EHQ:	1st stage, W2 2nd stage, DH
----------------------------------	--------------------------------

#### AIR CONDITIONING WITH ELECTRIC HEAT

Typical applications would be to use a 1-stage cool, 1-stage heat wall thermostat for 5Kw installations, and a 1-stage cool, 2-stage heat wall thermostat for 10 or 15Kw installations. Listed below are the appropriate control circuit wiring diagrams based on Kw rating.

Model B18EHQ1, B24EHQ1, B30EHQ /0Kw	CCD-1
Model B18EHQ1, B24EHQ1 w/5Kw or B30EHQ w/5Kw	CCD-2
Model B18EHQ1, B24EHQ1 w/15kw; B30EHQ w/10 or 15Kw	CCD-3

#### HEAT PUMP WITH ELECTRIC HEAT

The system and its safety controls are designed in such a manner that the heat pump and up to 10Kw (5Kw for B30EHQ) of the resistance electric strip heaters can operate at the same time, being brought on in stages. If there is 15Kw (10 or 15Kw for B30EHQ) installed in the blower coil unit, the remaining 5Kw (5 or 10Kw for B30EHQ) is utilized as the heat pump "replacement" heat. The "replacement" heat is brought on automatically if the wall thermostat is switched to "Emergency Heat" position, or if the compressor is de-energized by a compressor cut-off at extreme outdoor temperatures. This allows for total heating capability in the event of a compressor shutdown for the above reasons.

Listed below are the appropriate control circuit wiring diagrams based on Kw rating.

Models B18EHQ1, B24EHQ1, B30EHQ /0Kw	CCD-4
Models B18EHQ1, B24EHQ1, B30EHQ/5 or 10Kw	CCD-5
Models B18EHQ1, B24EHQ1, B30EHQ/10 or 15kw	CCD-6

#### WALL THERMOSTATS

The following wall thermostats and subbases should be used as indicated, depending on the application.

Appli- cation	KW	THERMOSTAT		SUBBASE	
		Part No.	Description	Part No.	Description
A/C	5, 10	8403-002	T 87F3111	8404-003	Q539A1220
A/C	15	8403-019	T 874C1000	8404-012	Q674A1001
H/P	All <sup>1</sup>	8403-017	T 874R1129	8404-009	Q674L1181
H/P	All <sup>2</sup>	8403-018	T 874N1024	8404-010	Q674F1261

<sup>1</sup> No automatic changeover position--must manually place in heat or cool. Reversing valve remains energized at all times system switch is in heat position (except during defrost cycle). No pressure equalization noise when thermostat is satisfied on either heating or cooling.

<sup>2</sup> Allows thermostat to control both heating and cooling operation when set in "AUTO" position. Reversing valve de-energizes at end of each "ON" heating cycle.

**IMPORTANT NOTE:** Both thermostat and subbase combinations shown above incorporate the following features: Man-Auto fan switch, Off-Heat-Cool-Em. Heat Switch, and two (2) indicator lamps--one for emergency heat and one for compressor malfunction.

#### BLOWER PERFORMANCE DATA

CFM — DRY COIL WITH FILTER		
E.S.P. Inches H <sub>2</sub> O	B18EHQ1, B24EHQ1, B30EHQ	
	Low/High 230V	Low/High 208V
.00	720/910	585/820
.10	700/880	575/800
.20	670/840	554/765
.30 <sup>1</sup>	650/800	535/730
.40	625/755	520/720
.50	590/710	500/705

<sup>1</sup> Maximum external static pressure when electric heaters are installed.

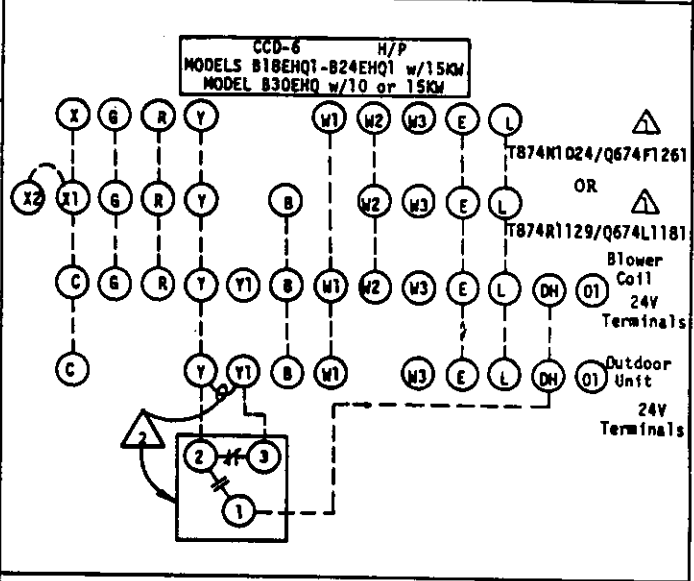
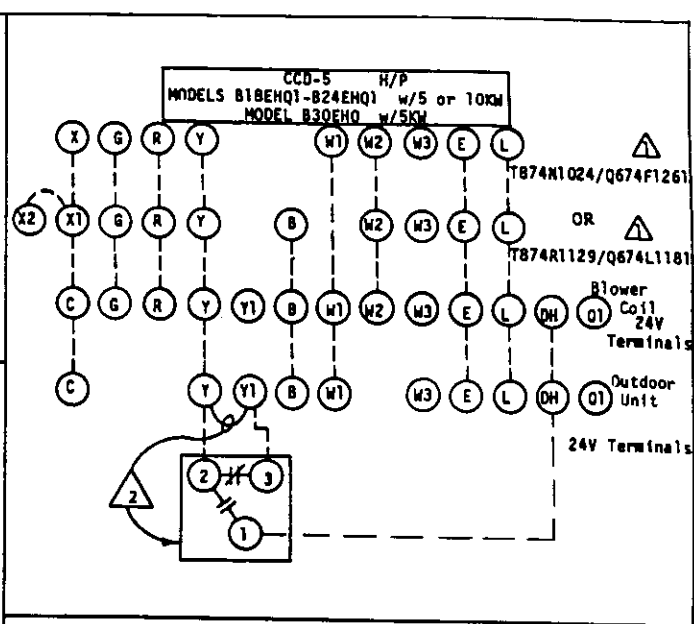
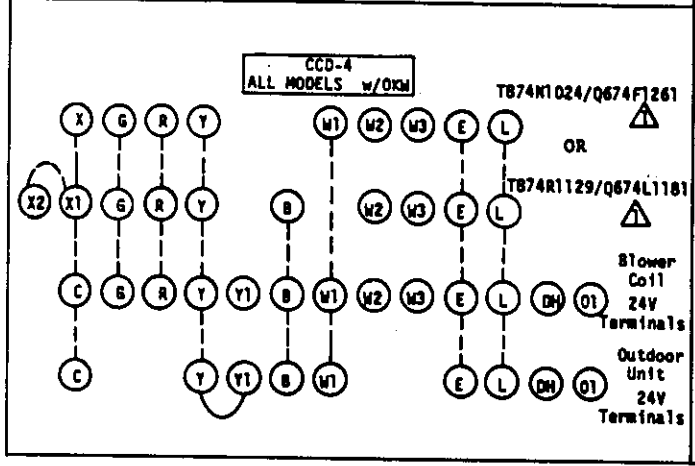
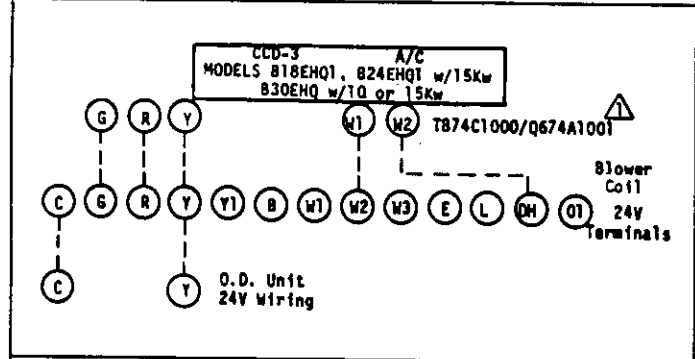
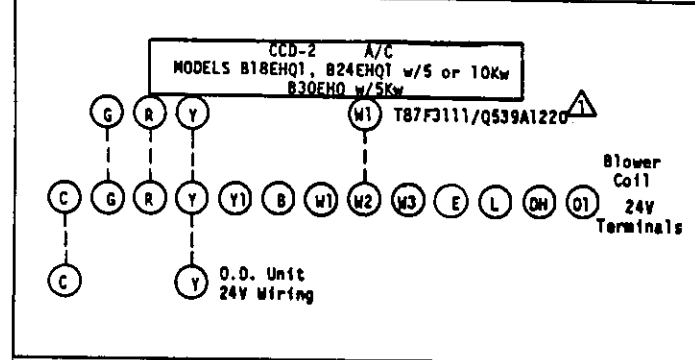
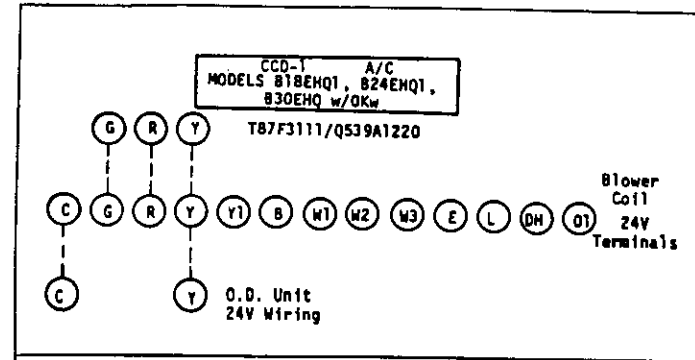

1 Set adjustable heat anticipator at .40A.  
 2 If optional compressor cutoff is installed,  
 remove jumper Y - Y1.

PARTS LIST  
SPLIT SYSTEM BLOWER COILS

Date: 05/10/89

Part No.	Description	B	B	B	B	B	B	B	B	B	B	B
		1	1	1	2	2	2	2	3	3	3	3
		E	E	E	E	E	E	E	E	E	E	E
		H	H	H	H	H	H	H	H	H	H	H
		Q	Q	Q	Q	Q	Q	Q	Q	Q	Q	Q
		1	1	1	1	1	1	1	1	1	1	1
			A	A		A	A	A		A	A	A
			0	1		0	1	1		0	1	5
			5	0		5	0	5		5	0	5
104-791	Angle	2	2	2	2	2	2	2	2	2	2	2
144-124	Diffuser	X	X	X	X	X	X	X	X	X	X	X
151-072	Blower Housing	X	X	X	X	X	X	X	X	X	X	X
4082-110	Wiring Diagram	X							X			
4082-111	Wiring Diagram				X							
4082-120	Wiring Diagram		X							X		
4082-121	Wiring Diagram					X						
4082-130	Wiring Diagram			X								
4082-131	Wiring Diagram						X					
4082-132	Wiring Diagram										X	
4082-141	Wiring Diagram							X				
4082-142	Wiring Diagram											X
5060-016	Evaporator Coil	X	X	X								
5060-028	Evaporator Coil				X	X	X	X	X	X	X	X
5152-008	Blower Wheel DD10-4A	X	X	X	X	X	X	X	X	X	X	X
5210-003	Strainer	X	X	X	X	X	X	X	X	X	X	X
5651-036	Check Valve	X	X	X	X	X	X	X	X	X	X	X
5811-001	Capillary Tube				3	3	3	3				
5811-010	Capillary Tube								3	3	3	3
5811-035	Capillary Tube	3	3	3								
7004-003	Filter 12x20	X	X	X	X	X	X	X	X	X	X	X
8103-012	Motor--Blower 1/5	X	X	X	X	X	X	X	X	X	X	X
8200-033	Motor Mount Band	X	X	X	X	X	X	X	X	X	X	X
8200-036	Motor Mount Arm	3	3	3	3	3	3	3	3	3	3	3
8201-009	Relay--Blower	X	X	X	X	X	X	X	X	X	X	X
8201-045	Relay--Time Delay				X	X	X	X				
8401-006	Contact--Heater 20A		1	1		1	1	2		1	1	2
8402-027	Thermal Cut-off		1	2		1	2	3		1	2	3
8402-028	Limit Switch L150-2.5					X	X	X		X	X	X
8402-029	Limit Switch L160-2.5											
8407-035	Transformer		X	X								
8552-002	Capacitor 5/370V	X	X	X	X	X	X	X	X	X	X	X
8604-023	Heat Strip 5KW			X						X		
8604-024	Heat Strip 10KW						X				X	
8604-025	Heat Strip 15KW			X								
8607-010	Terminal Block	X	X	X	X	X	X	X	X	X	X	X
8607-013	Terminal Block	X	X	X	X	X	X	X	X	X	X	X

NEC CLASS 2 Wiring  
Refer To Installation Instructions

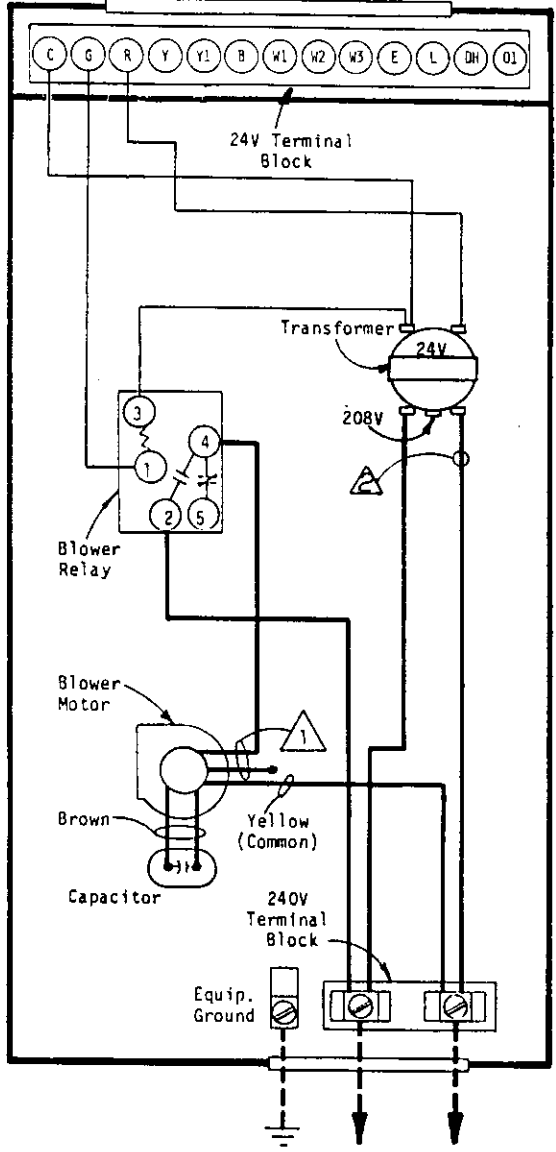

240/208-60-1  
240/220-50-1

FACTORY WIRING	FIELD WIRING
Low Voltage ———	—————
High Voltage ———	—————

⚠ For 208V operation move this wire to 208V transformer tap.

⚠ All models factory connected on high speed (Black). 1-1/2 ton models only may be reconnected to low speed (Red) by installer if matched with 18HPQ5 outdoor unit.

4082-110

NEC CLASS 2 Wiring  
Refer To Installation Instructions

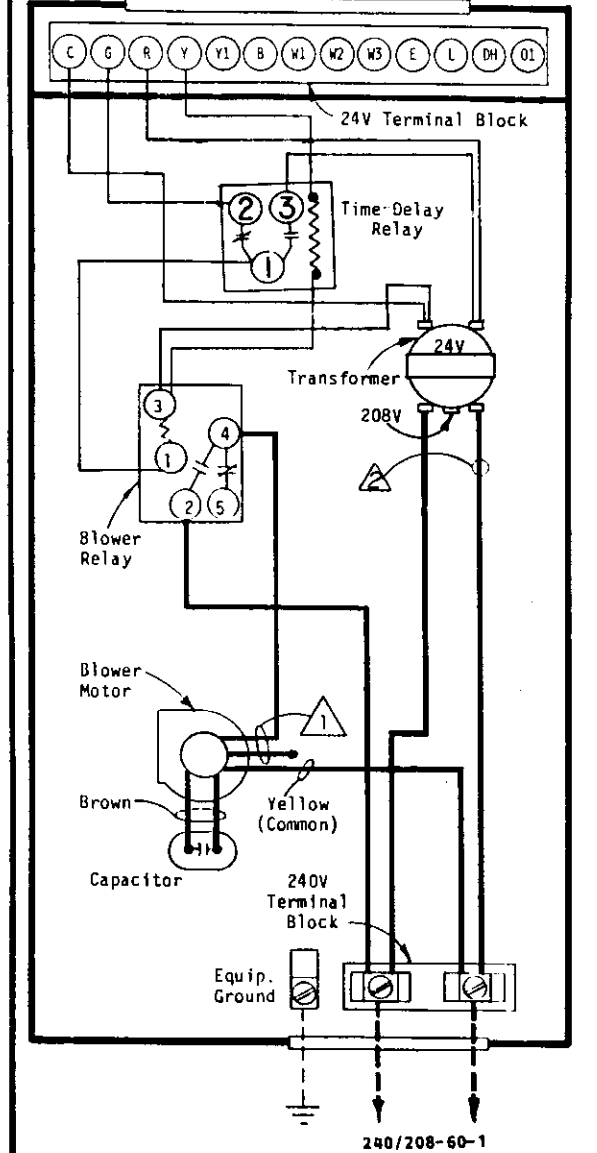

FACTORY WIRING	FIELD WIRING
Low Voltage ———	-----
High Voltage ———	-----

- ⚠ For 208V operation move this wire to 208V transformer tap.
- ⚠ All models factory connected on high speed (Black). 1-1/2 ton models only may be reconnected to low speed (Red) by installer if matched with 18HPQ5 outdoor unit.

4082-111



⚠ For 208V operation move this wire to 208V transformer tap.

NEC Class 2 Wiring  
Refer to Installation Instructions

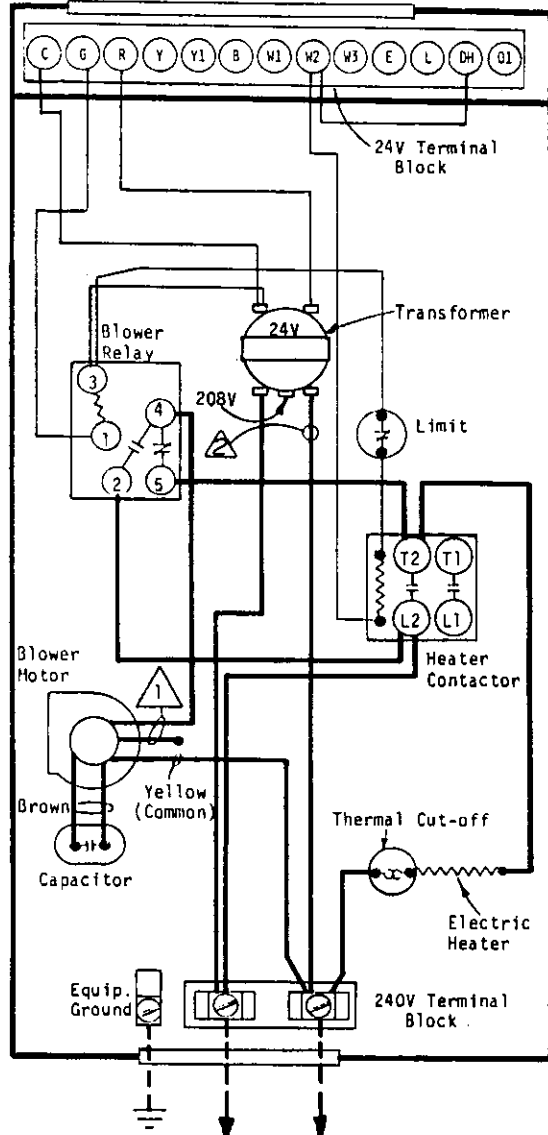

240/208-60-1

FACTORY WIRING	FIELD WIRING
Low Voltage ———	-----
High Voltage ———	-----

⚠ All models factory connected on high speed (Black). 1-1/2 ton models only may be reconnected to low speed (Red) by installer if matched with 18HPQ5 outdoor unit.

4082-120

⚠ For 208V operation move this wire to 208V transformer tap.

NEC Class 2 Wiring  
Refer to Installation Instructions

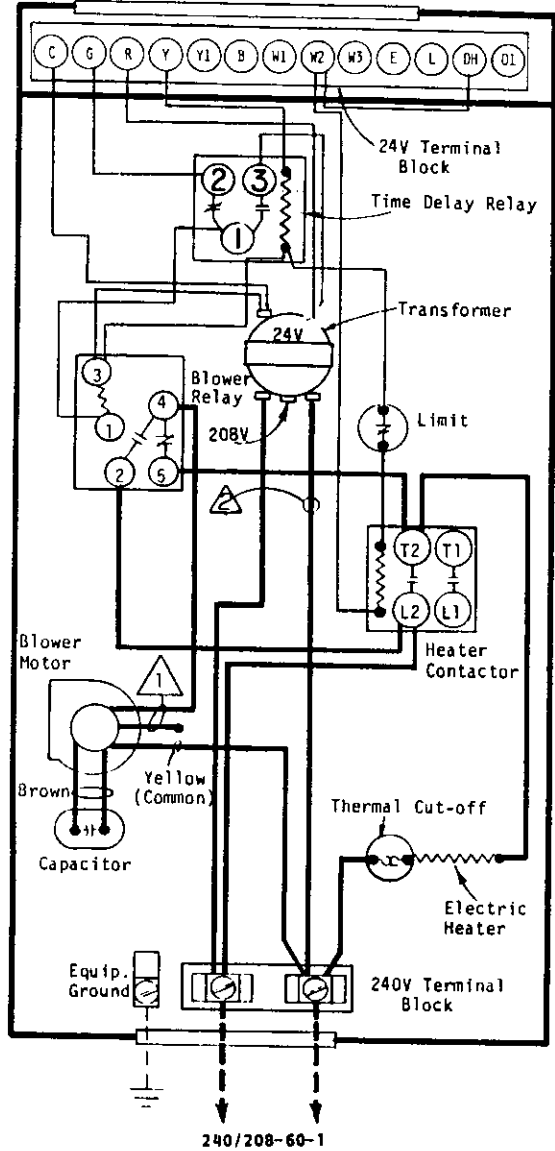

FACTORY WIRING	FIELD WIRING
Low Voltage ———	-----
High Voltage ———	-----

⚠ All models factory connected on high speed (Black). 1-1/2 ton models only may be reconnected to low speed (Red) by installer if matched with 18HPQ5 outdoor unit.

40B2-121

NEC Class 2 Wiring  
Refer to Installation Instructions

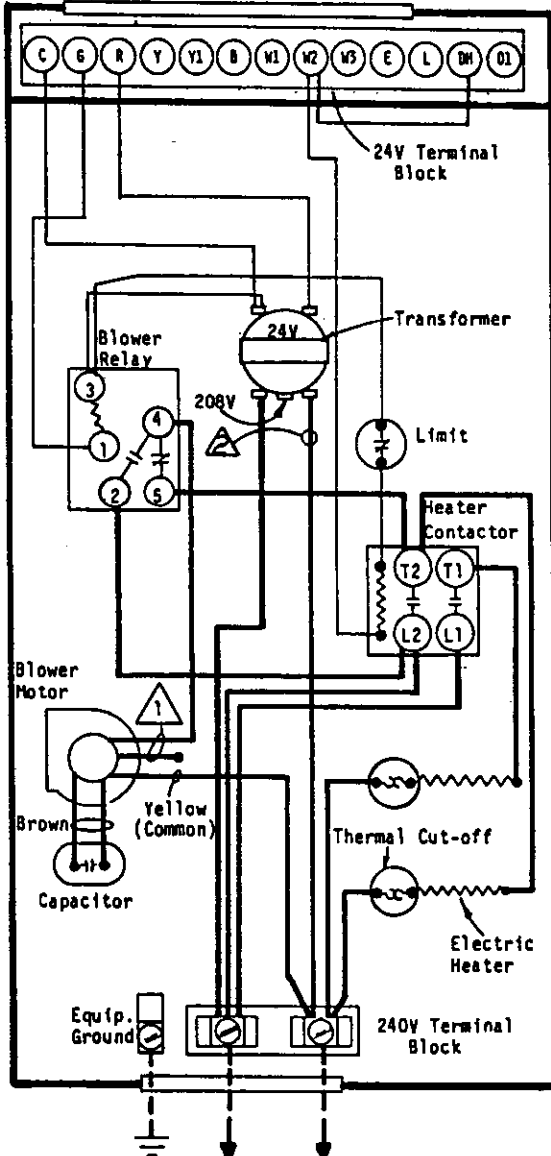

240/208-60-1  
240/220-50-1

FACTORY WIRING	FIELD WIRING
Low Voltage ———	-----
High Voltage ———	-----

⚠ All models factory connected on high speed (Black). DO NOT use low speed (Red).

⚠ For 208V operation move this wire to 208V transformer tap.

4082-130

NEC Class 2 Wiring  
Refer to Installation Instructions

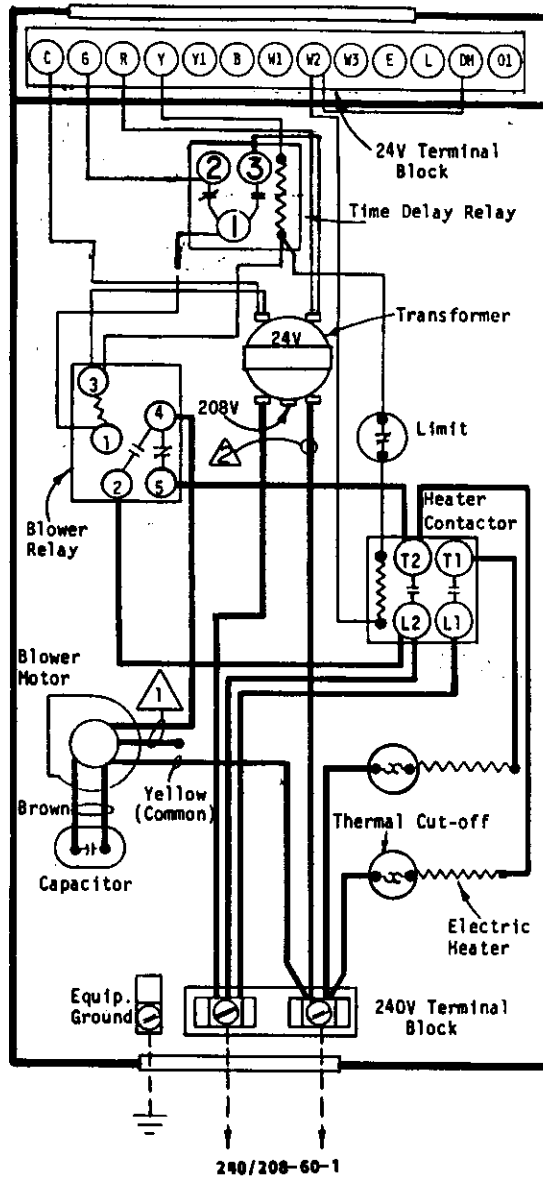

240/208-60-1

FACTORY WIRING	FIELD WIRING
Low Voltage ———	-----
High Voltage ———	-----

1 All models factory connected on high speed (Black). DO NOT use low speed (Red).

2 For 208V operation move this wire to 208V transformer tap.

4082-131

.NEC Class 2 Wiring  
Refer to Installation Instructions

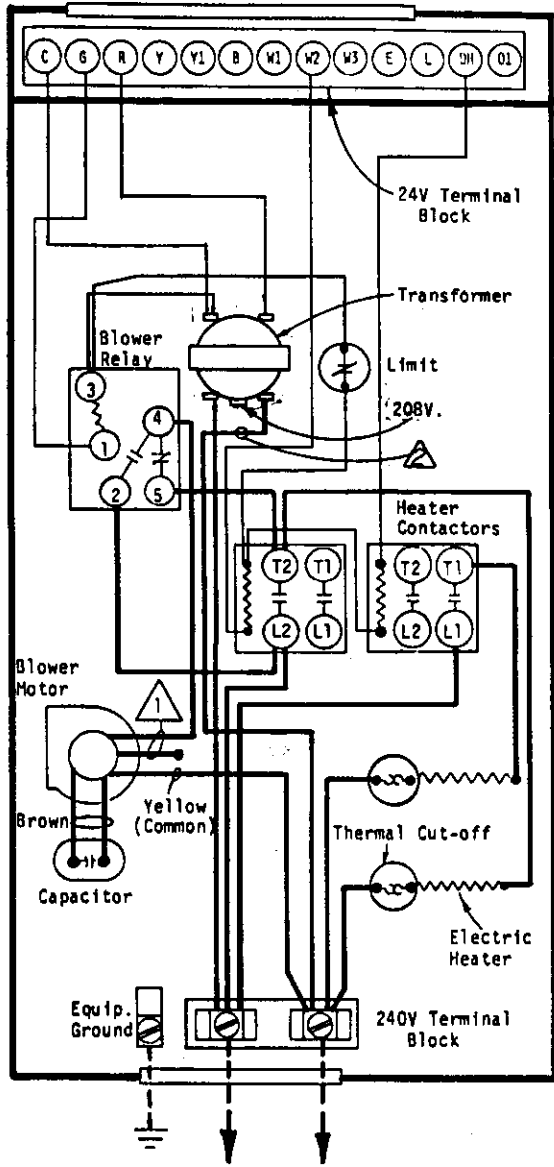

240/208-60-1  
240/220-50-1

FACTORY WIRING	FIELD WIRING
Low Voltage ———	—————
High Voltage ———	—————

⚠: Factory connected on high speed (Black). DO NOT use low speed (Red).

⚠ For 208V operation move this wire to 208V transformer tap. 40B2-132.

- 1 2-ton models connected on high speed (Black). Low speed (Red) not to be used.
- For 280V operation move this wire to 208V trans. tap. Use NEC Class 2 Wiring. Refer to Installation Instructions for recommended low-voltage wiring in conjunction with Matching outdoor unit.

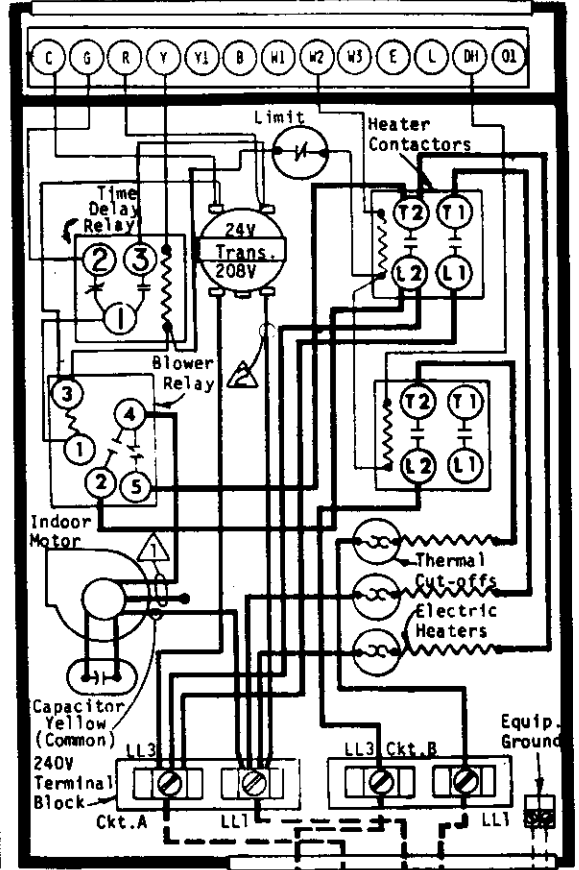

15kw models must use RFP-15 Fuse Panel Assembly

RFP-15

**USE COPPER OR ALUMINUM WIRE**

MOTOR SPEED IDENTIFICATION	
Common	- Yellow
High	- Black
Low	- Red
Capacitor	- Brown

FACTORY WIRING	FIELD WIRING
Low Voltage	-----
High Voltage	-----

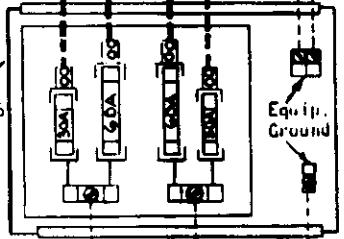

240/208-60-1

4082-141

- ⚠ Factory connected on high speed (Black). Low speed (Red) not to be used.
- ⚠ For 208V. operation move this wire to 208V. tap. Use NEC Class 2 Wiring. Refer to Installation Instructions for recommended low-voltage wiring in conjunction with Matching outdoor unit.

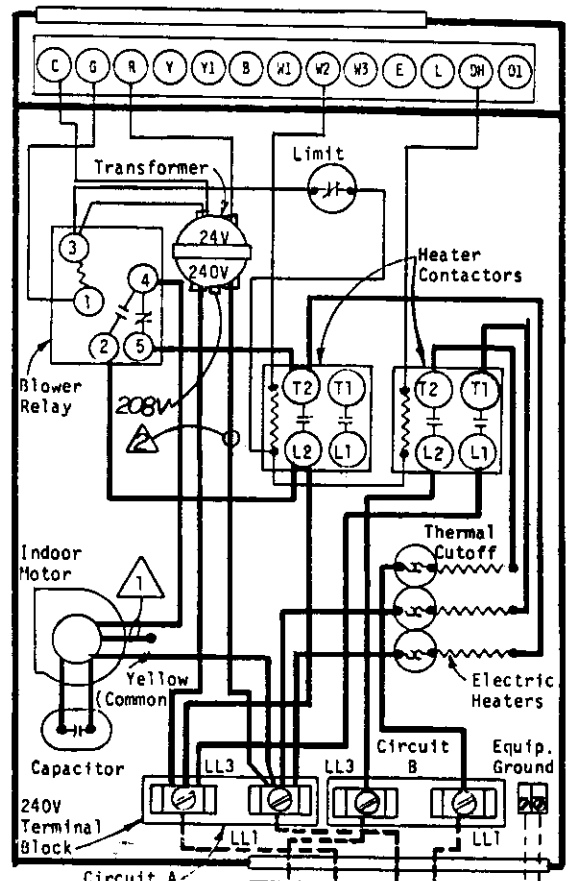

USE COPPER OR ALUMINUM WIRE

15kw models must use RFP-15 Fuse Panel Assembly

MOTOR SPEED IDENTIFICATION	
Common	- Yellow
High	- Black
Low	- Red
Capacitor	- Brown

FACTORY WIRING	FIELD WIRING
Low Voltage	-----
High Voltage	- - - - -

4082-142