

MANUAL 2100-058



## **BASIC ELECTRICITY**

## **REFRIGERATION, HEATING AND AIR CONDITIONING**

**BARD MANUFACTURING CO. • BRYAN, OHIO 43506**

*Dependable quality equipment... since 1914*

**SAFETY**

Although electricity is vitally important in carrying out our daily functions. It can also be deadly if handled carelessly. One tenth of an ampere of alternating current flowing through a vital organ can be fatal. Safety precautions must be taken whenever working with electricity. The following is a list of precautions to keep in mind.



Don't take chances with electricity.

1. Never cut off the third prong of a grounded plug. A grounded plug makes power tools and appliances safer to operate.
2. Never touch any wire without making sure that it is not a live wire.
3. Never turn an electrical appliance on or off while your skin is wet. Dry skin has a resistance of more than 100,000 ohms; wet skin's resistance is 1,000 ohms.
4. A current flow of .02 amperes is the maximum that a muscle can carry and still pull away from a conductor.
5. Always disconnect the master switch or main disconnect before working on an electrical line or circuit.
6. Always unplug an electrical appliance before working on it. Simply turning it off does not necessarily make it safe.
7. Replace worn appliance cords.
8. Unplug cords by pulling on the plug—not the cord.
9. Never turn an appliance on or off while standing in or touching a wet area.
10. Notify the proper authorities whenever you find broken electrical wiring touching the ground. Do not attempt to touch the wire with another object.
11. When working on electrical wiring that is live, try to use one hand only. If a person is shocked using one hand, current will probably flow through the hand and down through the feet. If a shock hits both hands, the electrical path would be through the heart, which could be fatal.

**ELECTRICAL SHOCK**

Here are some interesting facts\* about the cause and effects of electrical shock.

**120 VOLTS AND LESS CAN KILL!** The real killer is the strength of the current, expressed in amperes; and the right amount of current at 120 volts can kill.

Voltage and our body resistance determine the amount of current that will flow through our body. Dry skin has a resistance of 100,000 to 600,000 ohms; wet skin has about 1,000 ohms resistance. Internal body resistance, hand to foot, varies from 400 to 600 ohms. Resistance from ear to ear is approximately 100 ohms (do you suppose this last fact is telling us something?)

With a skin and internal body resistance of 1200 ohms, 100 milliamps (ma), or 1/10 of an ampere, is definitely enough current to cause death. Following are the effects from shock caused by currents of various values.

Safe Current Values

- 1 ma: Causes no sensation—not felt.
- 1 to 8 ma: Sensation of shock, but not painful; individual can release his contact at will, as muscular control is not lost.

Unsafe Current Values

- 8 to 15 ma: Painful shock; individual can let go at will; control not lost.
- 15 to 20 ma: Painful shock; muscular control of adjacent muscles lost. Cannot let go.
- 20 to 75 ma: Painful shock; severe muscular contractions with breathing extremely difficult.
- 100 to 200 ma: Painful shock; causing ventricular fibrillation of the heart. This is "irregular twitching of the wall of the ventricle of the heart." It is a fatal heart condition for which there is no known remedy or resuscitation. It means DEATH!
- 200 ma or over: Severe burns; severe muscular contractions—so severe that chest muscular reaction clamps the heart and stops it for the duration of the shock. This reaction prevents ventricular fibrillation. Artificial respiration should be administered immediately and in most cases, the victim can be revived.

\*Data compiled by Dr. Poitoff of the National Safety Council and by the Pacific Telephone and Telegraph Company.

**TABLE OF CONTENTS**

	PAGE
Safety . . . . .	1
Basic Electricity. . . . .	2
Electron Theory. . . . .	2
Sources of Electrical Current. . . . .	3
Electrical Fundamentals. . . . .	4
Voltage, Current and Resistance. . . . .	4
Direct and Alternating Currents. . . . .	5
Understanding Common Circuits. . . . .	5
Series Circuit . . . . .	5
Parallel Circuit . . . . .	6
Series Parallel Circuit. . . . .	6
Ohm's Law. . . . .	7
Electric Power - Watts . . . . .	8
Magnetism. . . . .	10
Electromagnet Effect . . . . .	11
Power Supply to Structure. . . . .	15
Control Circuit Electricity. . . . .	16
Parts of An Electrical Circuit . . . . .	19
Common Loads . . . . .	25
Resistance . . . . .	25
Inductive. . . . .	25
Electric Motors. . . . .	26
Capacitive . . . . .	28
Wire Sizes . . . . .	29
Electrical Symbols . . . . .	31

**BASIC ELECTRICITY**

Although very important, electricity is little understood by the average person. Electrical knowledge is useful to everyone, but to heating and cooling equipment service technicians, this knowledge is essential. All heating and cooling equipment utilizes electricity in one way or another. In order to service this equipment effectively, one must understand the principles of electricity.

**DEFINITION**

Electricity is a form of energy. Energy is the potential to do work. Energy can neither be created nor destroyed, it merely changes from one form to another. Electrical energy can be converted to light energy, mechanical energy and heat energy. Electricity is the movement of electrons. These electrons can be harnessed, stored and put to work for man. To understand how this is done, one must examine the theory of the electron.

**ELECTRON THEORY**

All matter, whether it is solid, liquid or gas, is composed of tiny particles called atoms. Millions of these atoms could be placed on the head of a pin and still not be seen. Atoms are composed of three even smaller particles. They are called electrons, protons and neutrons. These three particles form atoms which look very much like miniature solar systems. The sun is the core of the solar system; protons and neutrons form the core or "nucleus" of the atom. The sun has planets revolving around it; the atom's nucleus has electrons revolving around it. These electrons travel at the speed of light (186,000 miles per second).

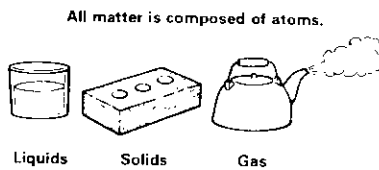

In the solar system, the gravitational pull of the sun holds the planets in their orbits. In the atom, the electrons are held in orbit by their attraction to the protons. Electrons have a negative (minus) charge while the protons have a positive (plus) charge. Neutrons have no charge. Oppositely charged particles (a plus charge to a negative charge) attract each other. Particles with like or similar charges (a plus charge to a plus charge or a negative charge to a negative charge) repel each other. Since electrons and protons have opposite charges, they are attracted to each other. This attraction holds the spinning electrons in orbit around the nucleus of the atom.

Atoms are composed of three smaller particles.

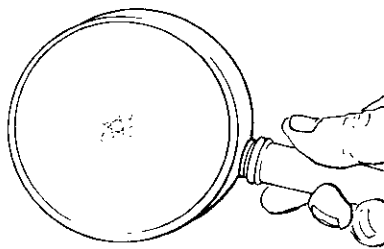

Atoms look like miniature solar systems.

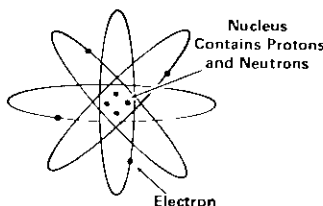

An atom has the same number of protons as electrons. This makes an atom "balanced". Electron orbits, however, vary in their distance from the nucleus. The electrons in orbit farthest from the nucleus are not attracted as strongly to the protons as the electrons closest to the nucleus. Under certain conditions, these outer electrons are knocked or forced out of orbit and become "free electrons".

When an electron is knocked from orbit, the atom has (one) more protons than electrons. This atom then has a net positive charge and becomes a "positive ion". An ion is any particle with a positive or negative charge. The positively-charged atom or positive ion would then try to pick up a stray electron to balance itself. This new electron might come from an atom nearby. The electron which was knocked from orbit will attach to another electron-deficient atom. This action creates a flow of electrons from atom to atom. This flow of electrons is called "electricity".

The quantity of electrons or electricity that can safely be transferred by a conductor is dependent on the size of the conductor. If an excess of electrons is pushed through a small conductor, large amounts of heat are generated. Therefore, the cross-sectional area of a conductor is the basis for sizing conductors or wire. Conductors are sized according to gauge numbers. The lower the gauge number, the larger the cross-sectional area.

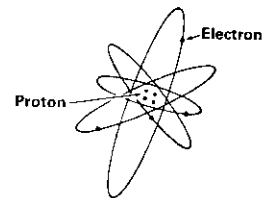

Electron orbits vary in distance from nucleus.

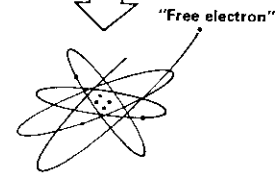

Some electrons are knocked out of orbit.

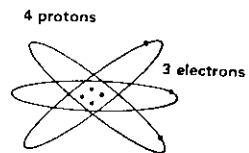

More protons - fewer electrons = positive charged atom

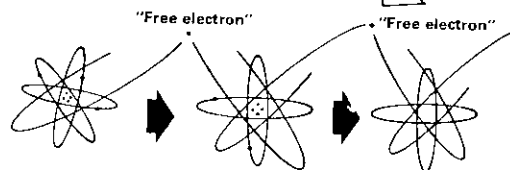

Atoms pick up "free electrons".

## SOURCES OF ELECTRICAL CURRENT

*Electricity is a form of energy, and must be obtained from another form of energy.*

*Chemical energy is converted to electrical energy in a battery. Action among different chemicals can cause electrons to be displaced. A continued chemical reaction results in the flow of displaced electrons or electron flow.*

*Mechanical energy is converted to electrical energy in a generator. The work of turning the generator shaft is converted to electrical energy.*

In order to put electrons to work, three items are necessary: a source, a path and a load. These items combine to form what is called an electrical circuit.

### SOURCE

In order for electrons to do work, an excess of electrons is gathered at a particular location. This location is called a source. The source could be an electric power plant or an ordinary automobile battery.

A battery will always have two terminals—one negative (-) and one positive (+). The excess of negatively charged electrons is gathered at the negative terminal in a battery, leaving a deficiency of electrons or positively charged ions at the positive terminal.

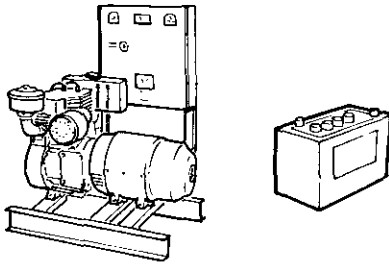

Typical Source — generator or battery

### PATH

There must be a way to transport the electrons from the source to the place where electrons will be put to work. A metal conductor or wire is usually the method used to transport electrons. This wire creates a path for the electrons to get to the point where work is to be done. This wire from the source to the work area is called the hot (H) leg of the circuit. (The hot leg will sometimes be designated "L1".)

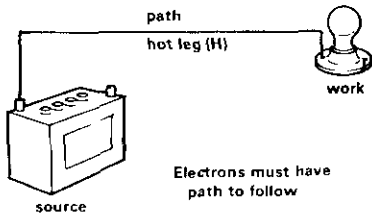

### LOAD

A load is the term used to designate the point in an electrical circuit where electrical work is to be done. The load will always have resistance to electron flow as electrical energy is converted to other forms of energy. These other forms of energy are heat energy (used in a toaster), light energy (used in a light bulb) and mechanical energy (used to run a clock). When electrical energy converts to other forms of energy, work is being done.

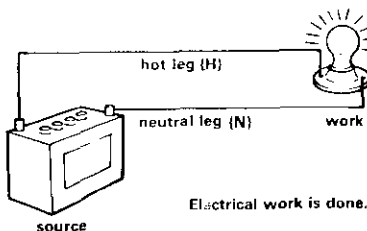

After the electron flow has passed through a resistance or load, there must be an electrical path from the load back to the source. The wire that runs from the load to the source is called the neutral (N) leg of the circuit. There is now a source, a path, a load and a path back to the source. This completes the circuit and allows the electrons to flow.

## CONDUCTORS

In order for electrons (electricity) to do work, they must be transported from one place to another. Electrons can be made to flow in all matter. However, this flow is much easier in some kinds of matter than others. The atoms of some matter hold on to their electrons in their outer orbits very tightly, while other forms of matter easily lose electrons from their outer orbit. To transport electrons, material should be selected that permits easy flow. Materials that permit this easy flow are referred to as conductors. Examples of good conductors are silver, copper, aluminum and mercury. Conductive material is usually formed into wire. Wire permits easy transportation of electricity over great distances.

The quantity of electrons or electricity that can safely be transferred by a conductor is dependent on the size of the conductor. If an excess of electrons is pushed through a small conductor, large amounts of heat are generated, creating a hazardous situation. Therefore, the cross-sectional area of a conductor is the basis for sizing conductors or wire. Conductors are sized according to gauge numbers. The lower the gauge number, the larger the cross-sectional area. The National Electrical Code sets the standards for the safe sizing of conductors. Measuring electron flow and determining the size of the conductor to be used will be discussed later in this section.

## INSULATORS

Insulators are those materials that have extremely low conductivity. These are materials that hold tightly to their electrons in their outer orbit. Some good insulators are rubber, plastic and glass.

The properties of conductors and insulators are essential in utilizing electricity. Conductors put electricity where it is needed; insulators isolate the flow of electricity.

GAUGE NO.	CROSS SECTIONAL AREA OF CONDUCTOR
20 GA.	
18 GA.	•
16 GA.	
14 GA.	
12 GA.	•
10 GA.	
8 GA.	•
6 GA.	•
4 GA.	

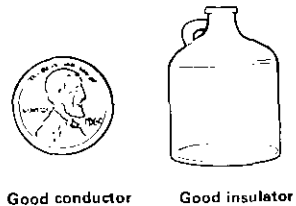

Good conductor

Good insulator

VOLTAGE, CURRENT, AND RESISTANCE

To get at the practical concept of electricity, let us consider for a moment the fluid flowing through a pipe, as shown in Figure 1. You must have: 1. A pressure driving the fluid from the pipe inlet to the outlet. 2. Fluid flow through the pipe. 3. Some opposition to the flow caused by friction or restrictions in the pipe.

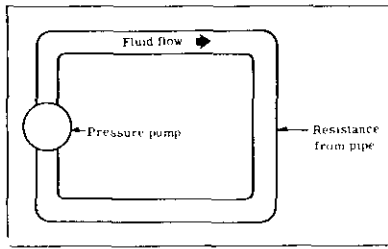

Figure 1 - Fluid flow through a pipe.

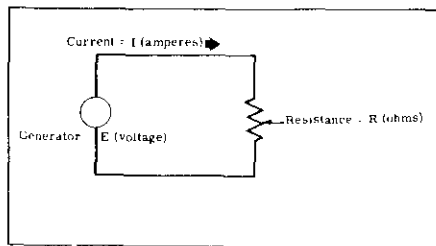

Figure 2 - Flow of electrons (electric current) through a conductor.

These same three conditions hold true for electricity, except that the names and symbols are different, Fig.2.

For electricity you must have: 1. A pressure between the conductor inlet and outlet called a voltage. 2. Flow through the conductor called an electric current. 3. Some opposition to the flow caused by "electrical friction" called resistance.

- E: voltage, or pressure, expressed as e.m.f. It is a unit of measure of the push, or pressure exerted against resistance.
- I: amperage, or quantity of current. Amperage measures the amount of flow of electrons per second.
- R: OHMS, resistance or opposition to flow.

VOLTAGE (Pressure Difference)

Voltage potential, potential difference, and electromotive force (emf) are all words for the same thing. Voltage is the measure of "pressure" which pushes the electrons through the circuit. Just as water will not flow through a pipe unless there is pressure behind it, so current will not flow through a wire unless there is voltage behind it.

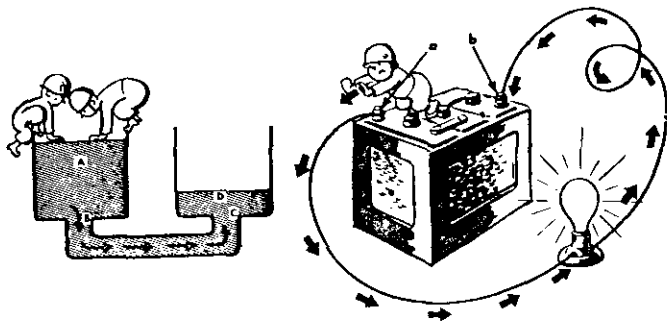

Figure 3 - Voltage (Pressure Difference)

In Figure 3, the pressure on the water in column A is greater than the pressure in column B. Therefore, due to the pressure difference, water will flow from B to C. Similarly, the electrical pressure (voltage) at A is greater than the electrical pressure at B and consequently electrical current will flow through the circuit.

AMPERAGE (Current Measurement)

Current is the "amount" of electricity passing a particular point in a circuit in a given time. This electrical flow is measured in amperes.

Just as we could place a water meter in the pipeline and measure the number of gallons per minute going through the pipe, we can place an ammeter in the circuit and measure the number of electrons going by each minute, or second.

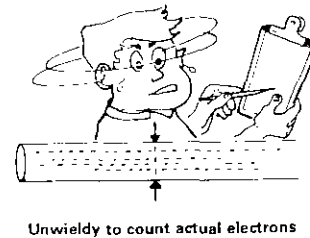

Electrons measured in AMPERES

Electron flow is measured in amperes (A). One ampere (or amp) equals 6.28 quintillion electrons passing a given point in one second.

Just as a water hose is sized according to amperage. For example, the chart below illustrates that a 14 gauge copper wire and a 12 gauge aluminum wire have a rating of 15 amps. This difference is due to the varying capabilities of different wires to carry electrons. Different materials require different size wire to carry the same quantity of electrons safely due to the amount of heat generated by friction within the wire.

AMPS	COPPER	ALUMINUM
15	14 GA.	12 GA.
20	12 GA.	10 GA.
25	10 GA.	8 GA.
30	10 GA.	8 GA.
35	8 GA.	6 GA.
40	8 GA.	6 GA.
45	6 GA.	4 GA.
60	4 GA.	4 GA.

Wire sized according to amperage.

RESISTANCE (Opposition to Flow)

Resistance is the opposition to electrical flow or current. Some materials allow current to flow through them easily and we say that they have a low resistance. Other materials do not allow current to pass through them and these have a high resistance (Figure 4).

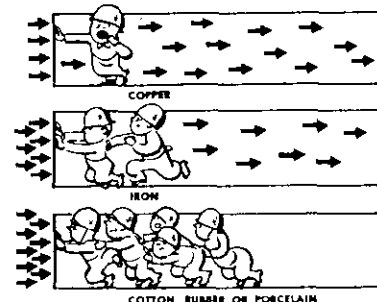

Figure 4 - Resistance

Point to be clear from now on: the length of the wire, temperature, and diameter are the important factors of the wire in use.

Resistance is measured in ohms. The more ohms, the greater the resistance.

Substances with low resistance are called conductors. Those with high resistance are called insulators.

Resistance is generally associated with a load. As electrons flow through a conductor, they have a tendency to crowd and push other atoms and electrons. This crowding is minimal and causes little resistance in the conductor. However, a load acts much like a funnel, causing greater crowding of the electrons. This resistance to flow causes heat. In the case of an electric toaster (heat energy), this heat is desirable. However, when electricity is converted to light or mechanical energy (i.e., light bulb, clock), heat is an undesirable by-product.

### GENERATING ELECTRICITY

To utilize electron flow or electric current, the source produces one of two basic types of electric current: alternating current (AC) or direct current (DC).

**DIRECT CURRENT** is said to be a current which flows in one direction only. This is based on the fact that electrons always flow from the negative terminal to the positive terminal. A chemical reaction inside the battery maintains the potential difference by depositing electrons on the negative terminal.

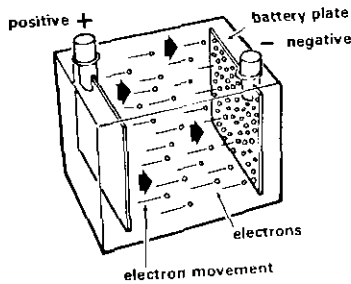

If a wire is connected from the negative terminal to a light bulb, then to the positive terminal, a circuit has been created. The electrons will move through the wire from the negative terminal to the light bulb then to the positive terminal. This is direct current. Direct current will continue to flow until the circuit is broken, or the source stops supplying electrons (due to a chemical breakdown in the case of a battery).

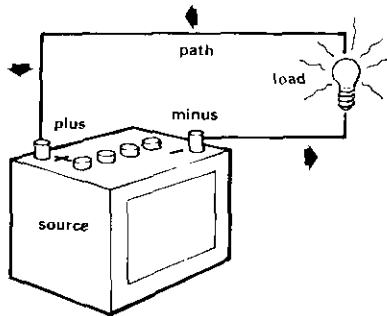

Electrons move from negative to positive.

**ALTERNATING CURRENT** flows from negative to positive but the force which causes the electrons to flow keeps changing from positive to negative, resulting in a current which flows through a conductor in one direction for a split second, then flows in the opposite direction for a split second. Current alternates because of a technique used at the power plant called electro-magnetic induction. This technique is based on power generated by passing a conductor through magnetic lines of force.

Induction involves the following principles:

1. Whenever there is an electron flow in the conductor, a magnetic field surrounds the conductor.
2. Whenever a conductor cuts magnetic lines of force, electrons are excited in the conductor and voltage is generated.

The generation of A.C. will be explained later.

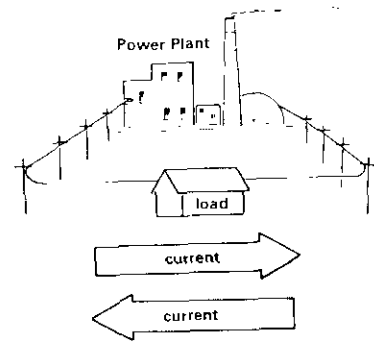

### UNDERSTANDING COMMON CIRCUITS

#### SIMPLE CIRCUIT

A simple circuit is a circuit that has a source, a path to the load (hot leg), a load and a path back to the source (neutral leg). With this circuit a toaster can toast, a light can glow and a clock can keep time. All electrical energy is used at the load. This electrical energy is converted to either heat energy, light energy or mechanical energy.

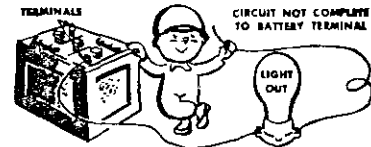
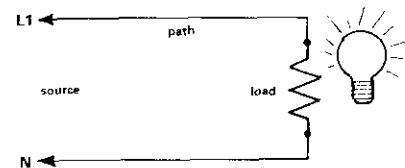

Incomplete Circuit

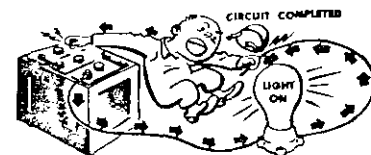

Complete Circuit

#### SERIES AND PARALLEL CIRCUITS

In refrigeration work it is often necessary to use two or more pieces of equipment in one electrical circuit. These pieces of equipment may be connected in a number of different ways. All circuits however intricate, may be divided into three general classes: series circuits, parallel circuits, and series-parallel circuits.

#### SERIES CIRCUIT

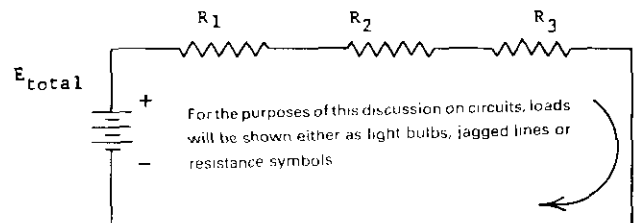

Series Circuit

SERIES CIRCUIT

A series circuit is one in which the resistance or other electrical devices are connected end to end so that the same current flows in each part of the circuit. Almost everyone is familiar with the string of Christmas tree lights in which all of the lights go out when any one of the lights burn out. These lights are connected in series.

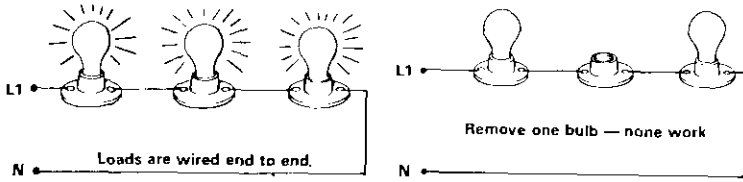

The three laws of a series circuit summarized below, should be committed to memory:

- a. The total resistance is the sum of the individual resistance.
- b. The same current flows in each part of the circuit.
- c. The sum of the voltage drops across the individual resistors is equal to the total or applied voltage.

The following formulas are very helpful in solving electrical circuits:

Total Resistance:  $R_{total} = R_1 + R_2$  or  
 $20 \Omega + 20 \Omega = 40 \Omega$

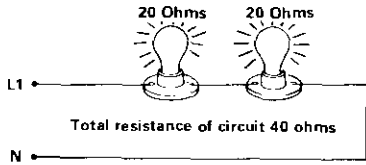

Total Current:  $I_{total} = \frac{E_{total}}{R_{total}}$

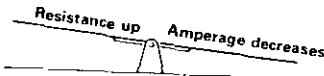
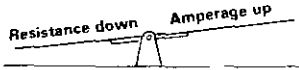

Voltage drop at resistor No. 1:  $E_1 = I \times R_1$

Voltage drop at resistor No. 2:  $E_2 = I \times R_2$

Voltage drop at resistor No. 3:  $E_3 = I \times R_3$

Total Voltage:  $E_{total} = E_1 + E_2 + E_3$

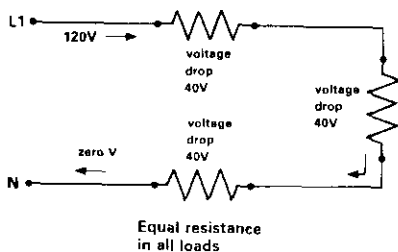

Equal resistance in all loads

PARALLEL CIRCUITS

In a series circuit only one path was provided through which the current might flow. There are also circuits which will provide more than one path through which current may flow. These circuits are known as parallel circuits.

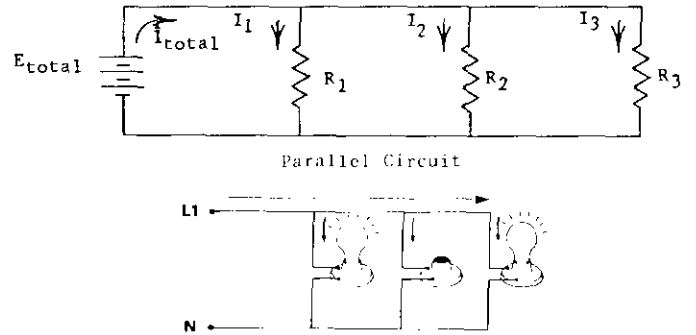

The three laws of a parallel circuit summarized below, should be memorized:

- a. The same voltage is across each resistor.
- b. The total current in a parallel circuit is equal to the sum of the currents flowing in the individual branches.
- c. The total resistance is always less than the smallest individual resistance in the circuit and can be found by dividing the applied voltage by the total current.

Total Voltage =  $E_{total} = E_1 = E_2 = E_3$

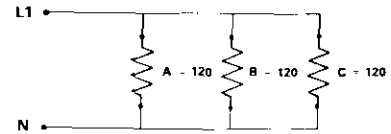

Current through Resistor No. 1 =  $I_1 = \frac{E}{R_1}$

Current through Resistor No. 2 =  $I_2 = \frac{E}{R_2}$

Current through Resistor No. 3 =  $I_3 = \frac{E}{R_3}$

Total Current =  $I_{total} = I_1 + I_2 + I_3$

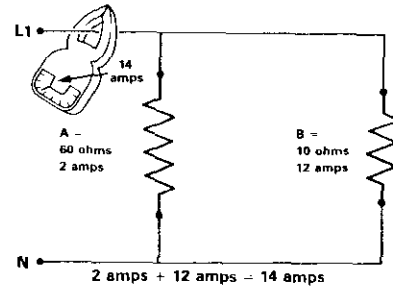

Total Resistance =  $R_{total} = \frac{E_{total}}{I_{Total}}$

Total Resistance  $\frac{1}{R_{Total}} = \frac{1}{R_1} + \frac{1}{R_2} + \frac{1}{R_3}$

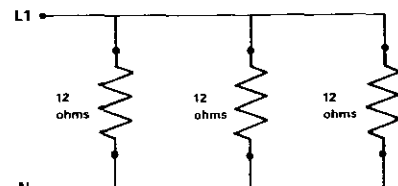

Equivalent resistance of circuit is 4 ohms.

**SERIES-PARALLEL CIRCUITS**

Series-parallel circuits consist of groups of parallel resistors in series with other resistors. Any leg of a parallel group may consist of two or more resistors in series. Series-parallel circuits may be solved by application of the rules already given for simple series and parallel circuits. To do this, the series-parallel circuit is reduced to an equivalent, simplified circuit. Each group of parallel resistors is first replaced by its equivalent single resistance, and the entire circuit is then treated as a series circuit.

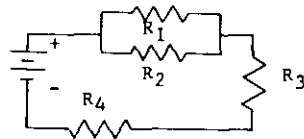

Series-Parallel Circuits (Four Resistors)

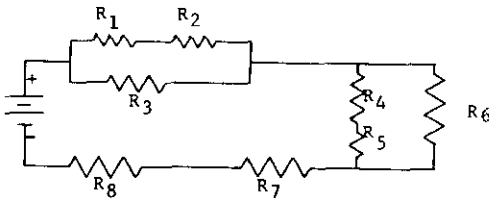

Series-Parallel Circuits (Eight Resistors)

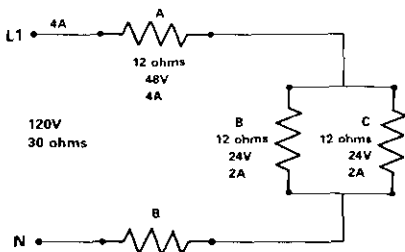
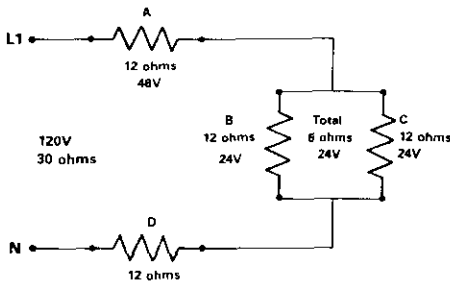
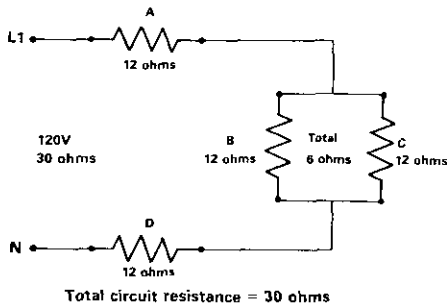

One vital part of circuit analysis is determining how many parts are connected in the circuit. Basically, there are only two types of circuits, series and parallel. A combination of these is called series-parallel.

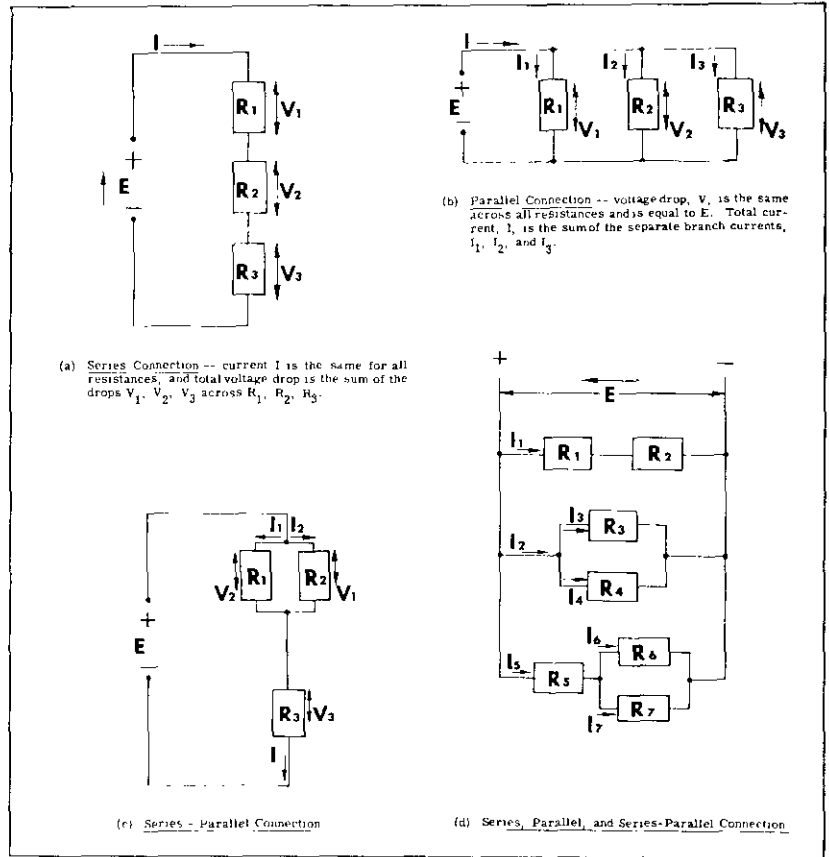

Schematic diagrams of basic electrical circuits.

**OHM'S LAW**

In 1827, George Simon Ohm found that the current flow  $I$  through a conductor was proportional to the applied voltage  $E$ , and inversely proportional to the resistance of the circuit  $R$ . Although today this statement seems hardly surprising—that is, that current  $I$  goes up when voltage  $E$  is increased and goes down when resistance  $R$  is increased—the equation expressing this relationship is a cornerstone of the modern use of electricity:

(1) Current in amperes ( $I$ ) =  $\frac{E.M.F. \text{ in volts } (E)}{\text{Resistance in ohms } (R)}$

or,  $I = \frac{E}{R}$

The equation can be used to find voltage and resistance when the other factors are known.

(2)  $R = \frac{E}{I}$

Or when current  $I$  and resistance  $R$  are known, voltage  $E$  can be found:

(3)  $E = IR$

**Memory Method.** The formulas for solving problems involving Ohm's Law must be learned. Do not bypass these formulas—they must be understood and remembered. A simple aid to memorizing the Ohm's Law formulas is shown in Figure 5. Part A of this figure shows a circle with the three symbols arranged in separate spaces. If any one of the symbols is covered, the arrangement of the other two symbols forms the right-hand side of the formula for determining the value of the covered symbol. Thus, if a finger is placed



over the I (B of Figure 5), E/R remains, and indicates that I is equal to E/R. If R is covered (C of Figure 5), E/I remains, and indicates that R equals E/I. In the same way, if E is covered (D of Figure 5), IR remains, and indicates that E equals IR.

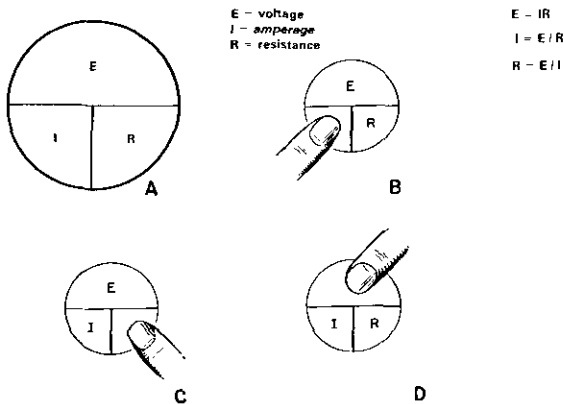

Figure 5 - Memory Aid for Learning Ohm's Law

Units of Measurement. It is best when solving problems with Ohm's law to use the practical units of measurement; that is, in terms of volts, amperes, and ohms. Problems are frequently given with fractional or multiple values of these units, such as the milliamperes, kilovolt, etc. When such values are given in a problem, convert all values to the basic units; volts, amperes, and ohms.

**SAMPLE PROBLEMS**

Some examples will clearly illustrate Ohm's Law.

**SERIES CIRCUITS**

Series Circuit Example 1 — Three 20-ohm loads in series give a total circuit resistance of 60 ohms. The total circuit voltage is 120 volts. To determine the total circuit amperage, divide 120 volts by 60 ohms. This equals 2 amperes. Since the amperage is the same throughout a series circuit, the total amperage is equal to partial amperages at each load. Individual load voltage drops can also be calculated with Ohm's Law. 20 ohms multiplied by 2 amps equals 40 volts. The sum of the individual voltage drops totals the source voltage of 120 volts.

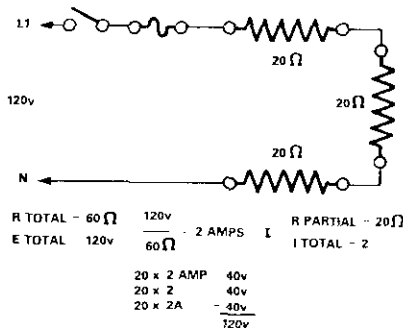

**PARALLEL CIRCUITS**

Parallel Circuit Example 1 — Here, 30 ohm loads are wired in parallel. The additional paths for electron flow give the effect of reduced circuit resistance. The equivalent resistance of these three loads is 10 ohms which makes the total circuit resistance 10 ohms. Equivalent resistances can be found by:

$$\frac{1}{R_T} = \frac{1}{R_1} + \frac{1}{R_2} + \frac{1}{R_3}$$

$$\frac{1}{R_T} = \frac{1}{30} + \frac{1}{30} + \frac{1}{30}$$

$$\frac{1}{R_T} = \frac{3}{30}$$

$$R_T = \frac{30}{3}$$

$$R_T = 10\Omega$$

Using Ohm's Law, find the total circuit amperage by dividing 120 volts by 10 ohms or 12 amperes. 12 amperes times 30 ohms equals 360 volts. This is not the potential difference at each load. Remember, in a parallel circuit, amperage divides. Here, each sub-circuit has the same resistance so the amperage will divide equally. This means that there will be 4 amps in each subcircuit. Since 120 volts is present across each path, Ohm's Law can be used to check this. 120 volts divided by 30 ohms equals 4 amps.

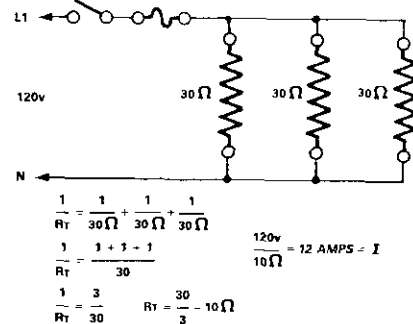

**SERIES-PARALLEL CIRCUIT**

Series-Parallel Circuit Example 1 — This is a series-parallel circuit with a 20 ohm load in series with two 20 ohm loads, which are in parallel with each other. The equivalent resistance of the two 20 ohm loads in parallel is 10 ohms. Therefore, the total circuit resistance is 30 ohms. 120 volts divided by 30 ohms equals 4 amperes. 4 amperes at load A means the voltage drop at load A is 80 volts. 120 volts minus 80 volts equals 40 volts left for load B and C. 40 volts divided by 20 ohms equals 2 amperes. Since the resistance was the same in each parallel leg, the 4 amps divided equally through each path.

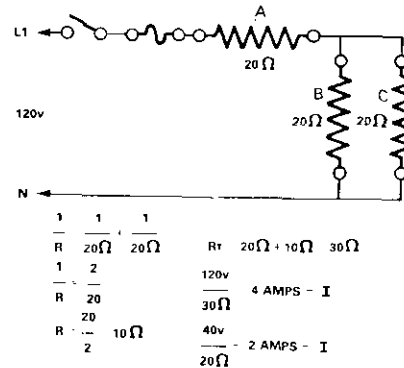

**ELECTRIC POWER**

When an electric current flows through a circuit, the circuit delivers "power" in the form of electrical energy, chemical energy, thermal energy, mechanical energy, etc. Thus, the passage of an electric current through a wire will result in the generation of heat or heat energy; when used to recharge a battery, it is transformed to chemical energy; when used to power a motor-driven blower, it is changed to mechanical energy.

The rate at which power is supplied to a direct-current circuit is represented by the equation:

Power (P) = Volts (E) x Amperes (I),

or, P = EI

Power may also be expressed in other forms of equations, which are shown in Figure 6. The unit of power is the watt (W). One very important form of the power equation is:

(5) P = I<sup>2</sup>R

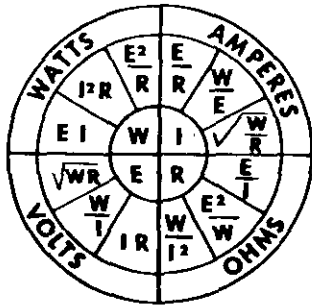
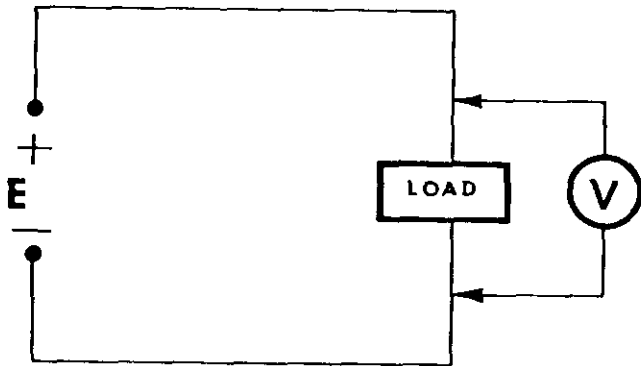

Figure 6 - Power equations wheel

Equation (5) shows directly the amount of electrical power delivered when current passes through a resistance. Now, assume  $I = 2$  amperes and  $R = 3$  ohms. Using equation (5), you can find that 2 amperes of current passing through a resistance of 3 ohms will require 12 watts of power.

What happens to this electric power? When delivered to a resistance load, it is changed from electrical energy to heat energy. If the process continues for one hour, 12 watt-hours of electrical energy will have been converted to heat energy. Since 1 watt-hour = 3.413 Btu, the circuit will develop 12 times 3.413 Btu of heat energy or about 41.0 Btu during 1 hour.



Voltage

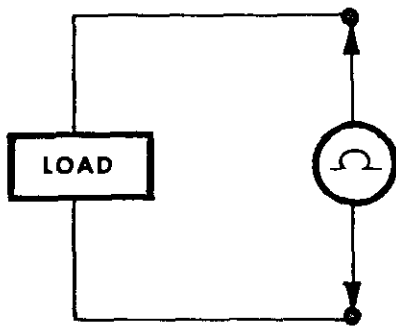

Resistance

MEASUREMENT

Figure 7 shows instrument connections to measure voltage, current, resistance and power. The e.m.f. or potential present at any point in a circuit is measured by a voltmeter connected across the circuit, and is expressed in volts. Current flow through the load is measured in amperes by placing an ammeter in "series" (see below) with the load. The direct-current resistance of an electrical component can be measured by first disconnecting the component from the circuit, and then using an ohm-meter across its terminals to obtain a reading in ohms.

The rate of energy consumption by the load is expressed in watts and is measured with a wattmeter. It should be remembered that watts is a rate of power consumption rather than total power consumption. Total power consumption depends upon how long power has been supplied at a certain rate and is usually measured in watt-hours or kilowatt-hours (1 kilowatt = 1000 watts).

WIRING SYMBOLS

The last two pages of this manual lists wiring symbols commonly used on circuit diagrams of heating and air conditioning systems. To indicate the various component parts, our discussion so far has dealt mainly with resistive components, but later we will discuss inductive, capacitive, and other components as well. The figure shows symbols for many of these.

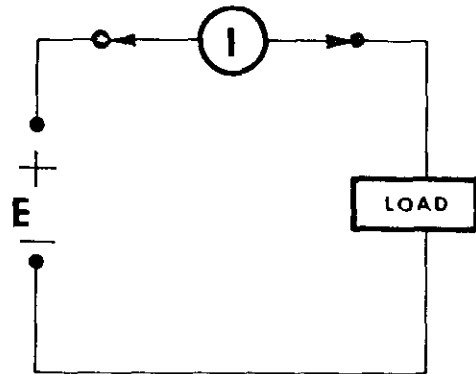

Current

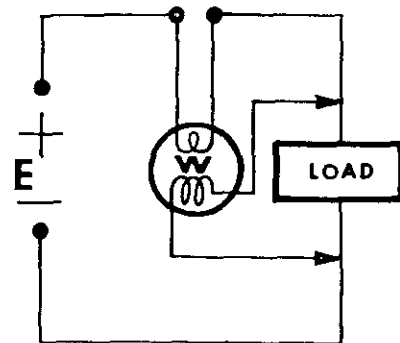

Energy Consumption

LEGEND:

- V - Voltmeter
- I - Ammeter
- Ω - Ohmmeter
- W - Wattmeter (includes current-carrying coil and voltage measuring coil)

Figure 7 - Basic electrical measurements.

MAGNETISM

Magnetism plays a major role in the operation of modern electrical devices. Permanent magnets are vital in the operation of many room thermostats. Figure 8 highlights some of the important features of permanent magnets.

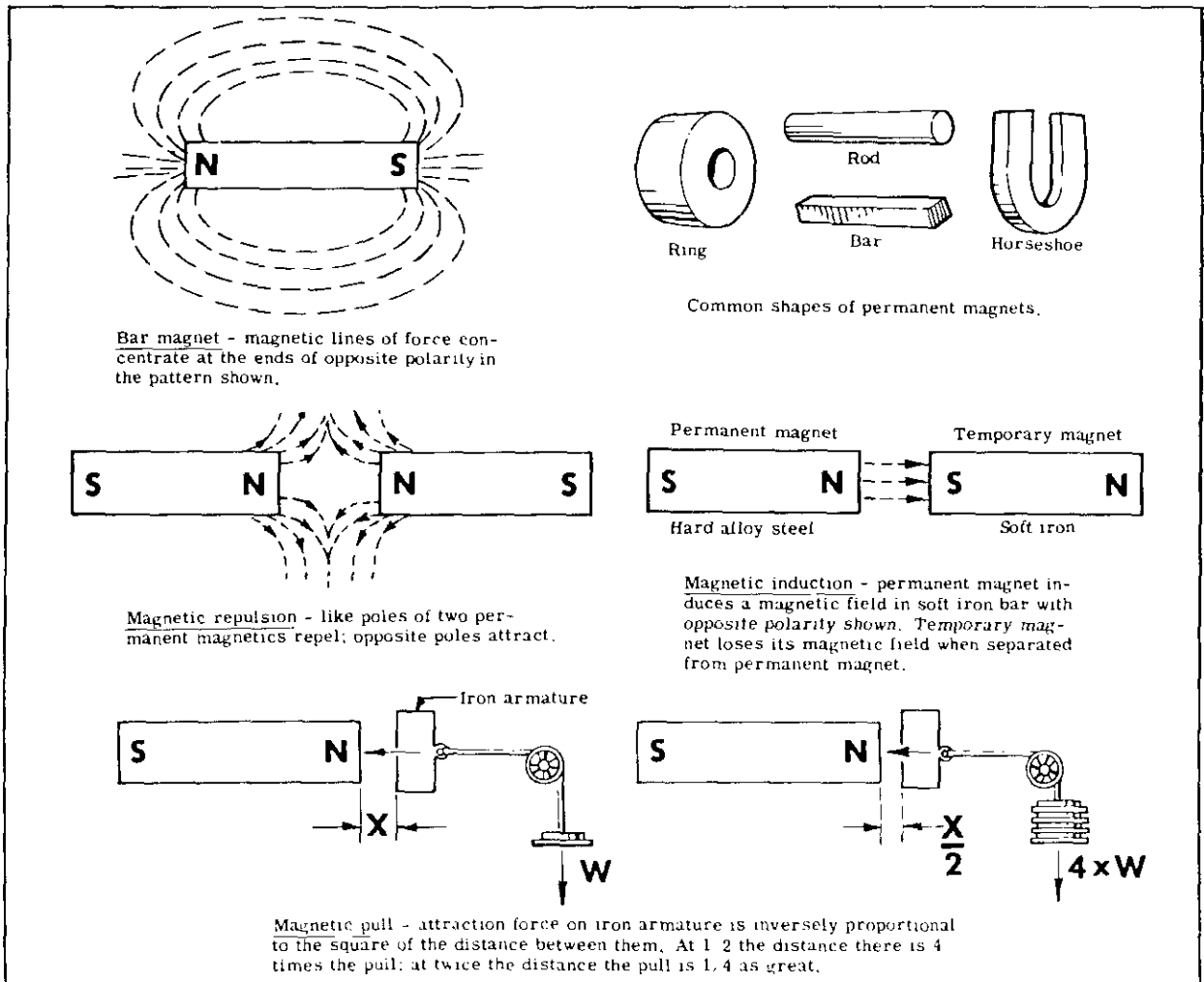

Figure 8 - Magnets and Magnetic Principles

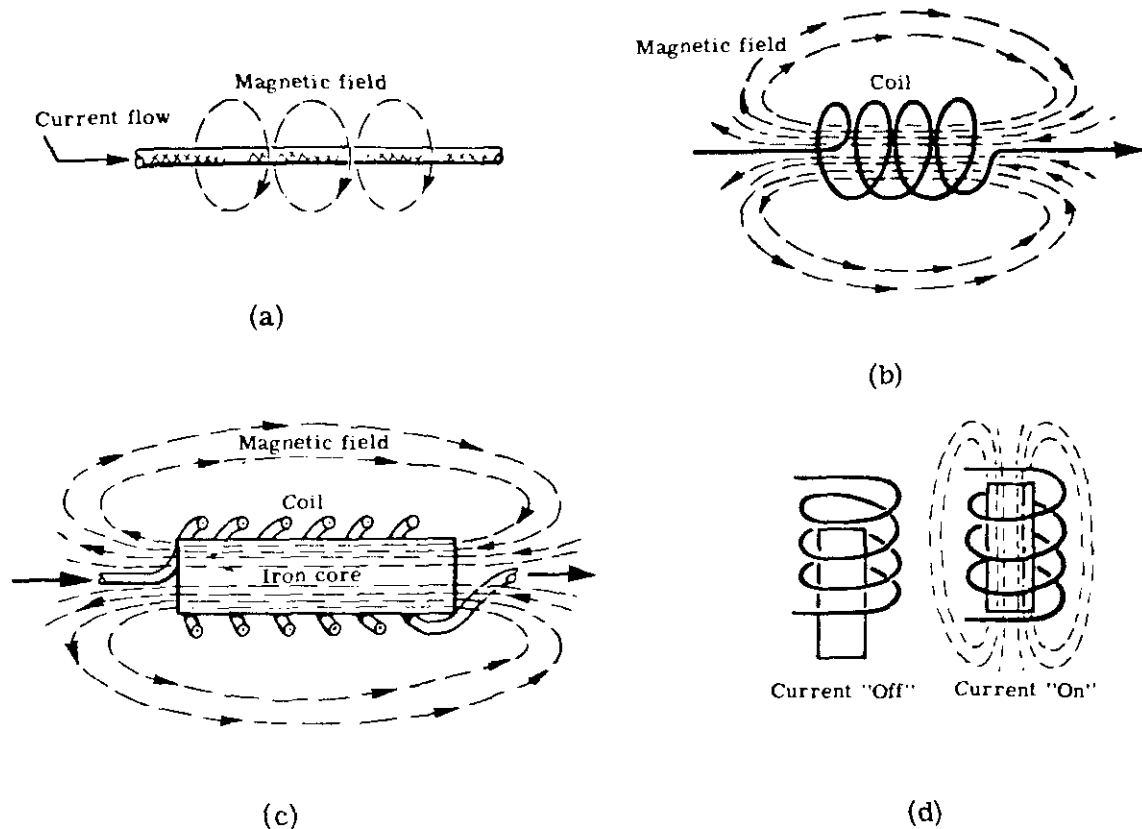

Figure 9 - Electromagnetic effects: (a) Magnetic field around current carrying conductor. (b) Magnetic field around air-core coil. (c) Magnetic field around solenoid coil with iron core. (d) Magnetic field around coil moves iron core when current flows through coil.

#### ELECTROMAGNETIC EFFECT

When electric current passes through a conductor, it sets up a magnetic field around the conductor, as shown in Figure 9 (a). If a compass (a freely suspended small magnet) is placed near the wire, the compass needle will deviate from its normal north-south position. We say that current flow through a conductor sets up magnetic "lines of force" around the conductor, which influences the compass. These lines of force exert a definite physical effect on magnetized or magnetic substances.

Normally, for a small current flowing through a single wire, this effect is of little importance. But by winding the conductor into a coil, Figure 9 (b), a more concentrated and useful magnetic field can be set up. We call such an electric winding a coil, or a solenoid. Its one important job is to increase the strength of the magnetic field to a usable level.

Now suppose we apply a d-c voltage across the ends of the coil. Once the magnetic field has been built up, the coil acts like a permanent magnet, having a north pole, a south pole, and lines of force.

Because air is a poor "conductor" of magnetic lines of force, we may place a soft iron core through the center of the coil, Figure 9 (c). This increases the number of lines of magnetic force, and therefore strengthens the magnetic field.

Figure 9 (d) illustrates a vertical coil and an iron core. It shows how a solenoid-operated plunger works. When voltage is applied to energize the solenoid, the electromagnetic field pulls the iron-core plunger up into the center of the solenoid. When the circuit is broken the plunger, no longer held by electro-magnetism, drops down because of the force of gravity or a spring.

The action of solenoid-operated plungers is widely used in control work. Such a plunger can be attached to a valve seat or disc. Energizing or de-energizing the solenoid attracts or releases the plunger, causing the attached valve seat to open or close the valve.

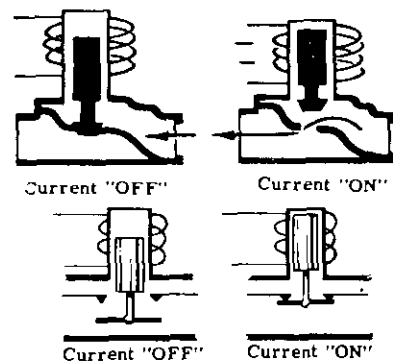

Figure 10 - Electromagnetic controls: (a) Magnetic valve. (b) Magnetic switch.

The magnetic valve shown in Figure 10 (a) illustrates this principle. With the coil de-energized, the valve stem and seat are held down by the force of gravity or a spring to shut off flow through the valve. When the coil is energized, its magnetic field lifts the valve stem and seat, opening the valve and allowing fluid to flow. Electro-magnetic valves are usually called "solenoid valves." You will find them used for starting or shutting off the flow of gas, oil, air, water and refrigerants.

The same electromagnetic principle is used to actuate many switching devices. Figure 10 (b), called electric relays, contactors, or motor starters. Only a small current need be passed through a coil to close or open the contacts, which in turn can switch comparatively large load currents on and off. Also, the voltage applied to the coil may be either the same or different from the voltage of the controlled circuit.

**ELECTROMAGNETIC INDUCTION**

In 1831, both Michael Faraday and Joseph Henry discovered and demonstrated the principle of electromagnetic "induction" which, as you will see, was a most important step in applying electric energy. If a magnetic field is moved past a conductor or if the conductor is moved through a magnetic field, and electromotive force is induced in the conductor. Figure 11 shows the experimental arrangement for demonstrating this effect.

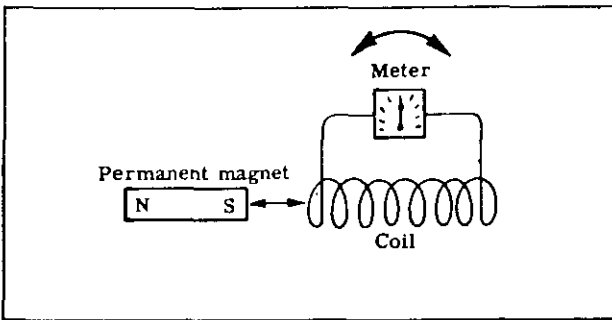

Figure 11 - Magnetic induction with stationary coil. Bar magnet is run in and out of coil to induce a current in the coil and cause a reading on the meter.

As the permanent magnet is moved into or out of the coil, its magnetic lines or force cut across the turns of the coil. This induces a voltage in the coil, which will be indicated by a sudden deflection on a voltmeter connected across the coil. As the permanent magnet is moved into and out of the coil, the direction of current flow reverses.

The conductor need not be formed into a coil. A magnet moved past a straight piece of wire will demonstrate the same effect. One application of the induction effect is in the transformer. Although the transformer will be discussed later in the section on alternating current, we might look briefly at its operating principle here. Figure 12 shows a primary winding connected to a battery. A secondary winding is placed close by, but is not connected to the primary winding. Opening or closing the power switch results in a sudden movement of the voltmeter connected across the secondary winding. The sudden increase or decrease of current through the primary winding has caused a magnetic field to build up or collapse. Since the lines of this field cut across the secondary winding, any sudden buildup or collapse generates a voltage in the secondary circuit.

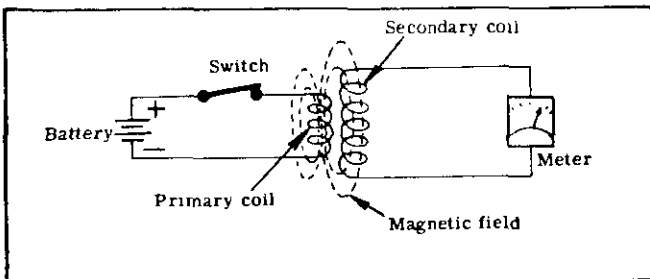

Figure 12 - Transformer principle: Opening and closing switch causes current to flow in primary coil thus setting up a varying magnetic field. Field cuts secondary coil and induces current in meter circuit.

**GENERATOR EFFECT**

The generator effect is in a sense the reversal of the electromagnetic effect. In a generator, a magnetic field is used to produce an electric current. As discussed previously, when a conductor cuts across magnetic lines of force, an e.m.f. or voltage is created, as shown in Figure 13 (a). If the conductor is formed into a closed loop, current will actually flow through the loop. A physical force must be exerted to move the closed loop through the magnetic field. Thus, in the generator effect, mechanical energy is changed into electrical energy.

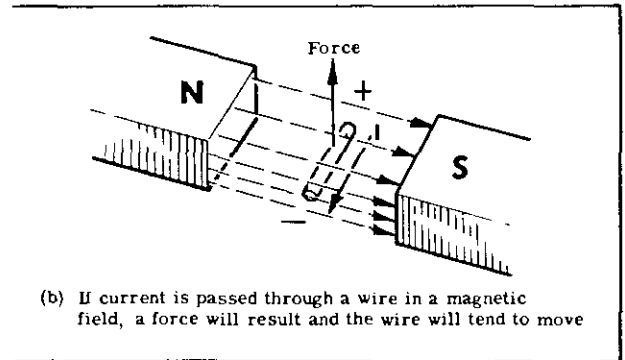
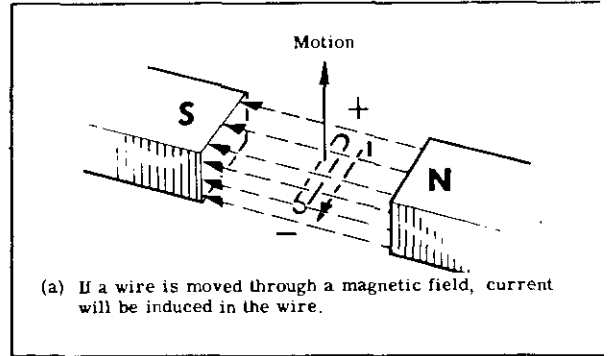

Figure 13 - Schematic of generator effect (a) and motor effect (b).

**MOTOR EFFECT**

Electrical energy can be changed into mechanical energy by applying the motor effect. When a conductor is placed in a magnetic field and current is passed through the conductor, a mechanical force is developed which tends to move the wire, Figure 13 (b). This force is the basis for all rotating electric motors.

**BACK E.M.F.**

When a voltage and current in a closed circuit are induced in a conductor by the motion of a magnet or magnetic field, an opposing magnetic field will be produced by the induced current in the conductor. Or as stated by Lenz's Law, a current set up by an induced e.m.f., will be in such a direction that its magnetic field opposes the motion generating the e.m.f. Referring again to Figure 11, the induced magnetic field set up in the coil tends to resist the movement of the magnet into the coil.

**ALTERNATING CURRENT**

So far we have been discussing basic electricity as applied to direct-current (d-c) circuits. Now let us turn to consider alternating current (a-c) circuits.

Early electrical systems were supplied power from d-c generators. While d-c power distribution still offers advantages in some applications, the alternating-current (a-c) system of power generation and distribution is greatly superior in most modern applications, and a-c power has been almost universally adopted through the United States.

Alternating current flows along a conductor first in one direction and then in the other. These reversals of direction occur periodically and very rapidly. Each change of direction is called an alternation and every two alternations are called a complete cycle. The number of cycles per second is called the frequency of the alternating current. In the United States, a standard frequency of 60 cycles per second (60 cps) is employed in most communities.

This rapidly changing direction and quantity of current in a conductor sets up a rapidly changing magnetic field around the conductors and in coil windings.

Figure 14 (a) shows the basic principle of how a-c may be generated. Figure 14 (b) is a graphic representation of a "sine wave" curve showing how the output voltage of an alternator can be illustrated.

The voltage starts at 0, rises to a positive maximum, decreases through 0 to a negative maximum, and then rises to 0, thus completing a single cycle to two alternations.

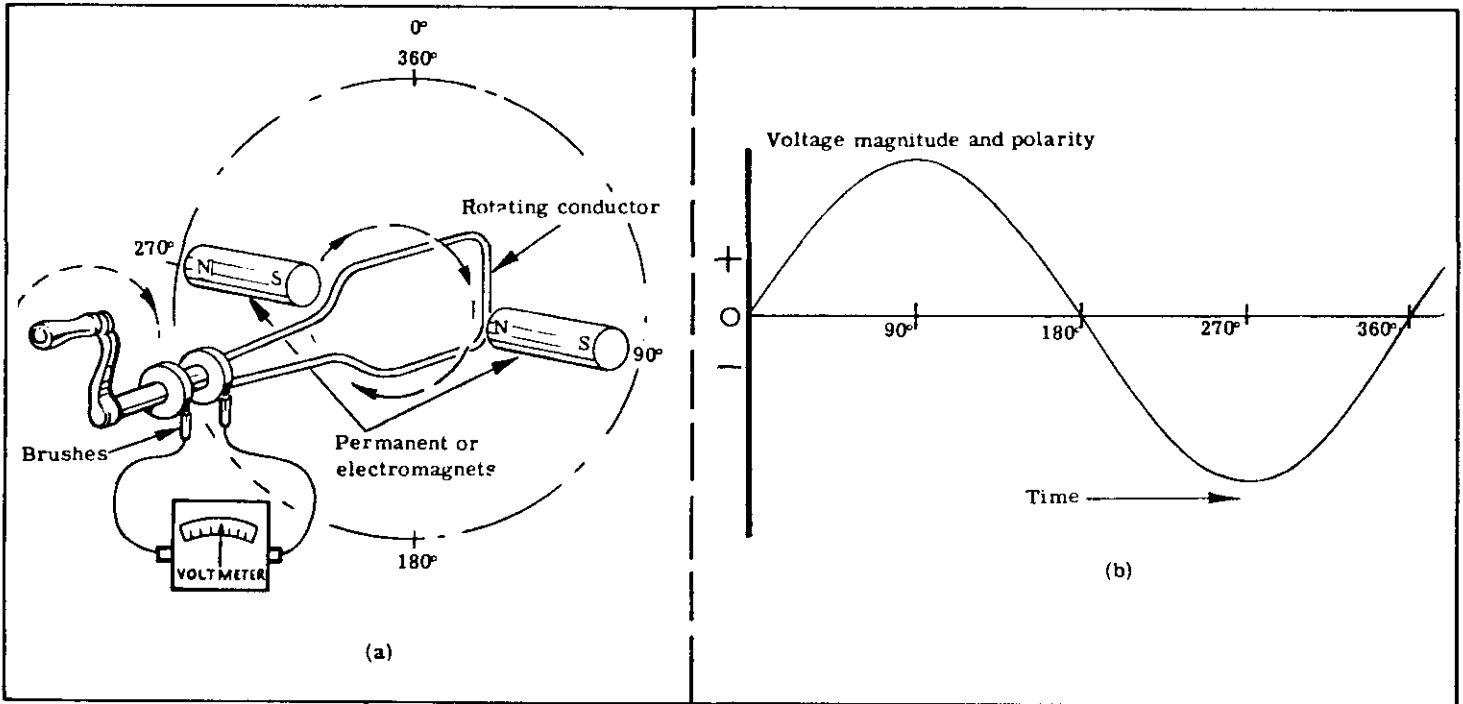

Figure 14 - Schematic of alternator (a), and typical sine wave curve of alternator voltage output (b).

**TRANSFORMERS**

The main advantage of a-c distribution is that voltage can be changed or "transformed" easily. The generated voltage can be stepped up or stepped down to almost any voltage required. Referring to Figure 12, you will recall that a conductor or coil could "induce" a voltage in a nearby conductor while the magnetic field of the primary coil was building up from zero to a maximum, and again when the magnetic field was collapsing from maximum to zero. In the same changing field, the voltage will be proportional to the number of turns of the coil in the "primary" and "secondary." Figure 15 illustrates the principle of a voltage transformer, which is a simple method of increasing or decreasing voltage of any a-c circuit. A core of iron is indicated in a form commonly used for better efficiency. Note that in any transformer, the wire sizes, number of coil turns, and size and construction of the iron core must vary with the power (watts or volt-amperes) requirements.

Transformers are rated or sized according to the amount of power the secondary can handle. The power capability is expressed in va, which means "voltage x amperage." If the secondary voltage of a transformer is 24v and the amperage capacity of the secondary is 2 amps, the va rating of that transformer is computed as follows:

$$\begin{aligned} \text{TRANSFORMER RATING} &= \text{VA} \\ \text{VA} &= \text{VOLTAGE} \times \text{AMPERAGE} \\ \text{VA} &= 24\text{V} \times 2 \text{ AMPS} \\ \text{VA} &= 48\text{VA} \end{aligned}$$

This transformer is rated at 48va. This is the operating capability of that transformer. This transformer should not be replaced by a transformer with a smaller va rating. In time, a smaller va rated transformer will burn out. The transformer can be replaced by one with a larger va rating.

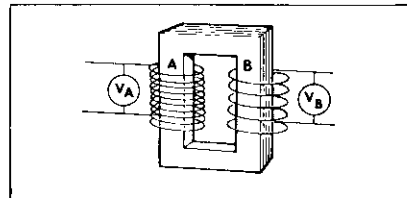

Figure 15 - Basic "step-down" or "step-up" transformer. "A" has twice as many turns as "B". If an a-c voltage is supplied to "A", the output voltage from "B" will be 1/2 of "V<sub>A</sub>". If "B" receives an input voltage, the output voltage at "A" will be twice "V<sub>B</sub>".

## INDUCTANCE

Now let us recall that as the amount of current flowing in a conductor changes, the magnetic field set up around the conductor expands or decreases, and the opposing or back e.m.f. set up resists the flow of current passing through the conductor. This is called self-inductance. While the magnitude of this inductance is relatively unimportant in a straight conductor, the resistance due to the inductive effect can be important and sizable when conductors are coiled. If a coiled conductor is carrying a-c, the "inductive resistance" can far exceed the "conductive resistance" of the conductor and depends on the number and spacing of the coil turns, type and location of iron "cores" etc. This "inductive resistance" is reactance and, like conductive resistance, is measured in ohms.

The voltage or "back e.m.f." set up by "induction" opposes the current flow. In an a-c circuit, the build-up of current in one direction and its decrease to zero is slowed by "inductance" so that the current "lags" behind the voltage changes. In a pure inductance load, the "current is out of phase" or falls behind the voltage changes by  $90^\circ$ . Graphically, Figure 16 shows this effect.

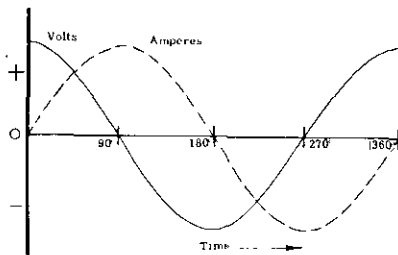

Figure 16. Relationship of voltage and current in a pure inductive circuit; i.e., a transformer. Current lags voltage by  $90^\circ$ .

## CAPACITANCE

In your work with controls and control motors, you will encounter components called capacitors or condensers. To understand how a capacitor works, let us assume we have two metal plates separated by an insulator (called a "dielectric"), and electrically connected to a battery through an ammeter and a switch, as shown in Figure 17.

The e.m.f. or voltage of the battery will force "free" electrons to flow toward one plate. This plate will accumulate a surplus of electrons, or a negative charge, while the other plate will become deficient in electrons and therefore will carry a positive charge. Electrons will continue to flow until the "potential difference" between the two plates becomes the same value as the battery voltage.

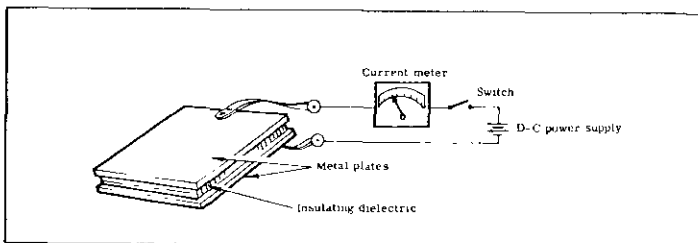

Figure 17. Schematic of a capacitor in a d-c circuit.

The capacitor actually stores electrical energy (in an "electric field" between its plates), and for a brief period while the plates are charging, a current will flow, as indicated by the ammeter. Once the plates become charged to the same voltage as the source, the current (flow of electrons) will stop. Then, if the capacitor is disconnected from the battery and the two plates are connected together, a discharge current will briefly flow, this time in the opposite direction.

It can be seen that a capacitor, when connected to a d-c source, will only momentarily carry a charging current or discharging current. Thus, after the initial surge of charging current, a capacitor serves to block direct current.

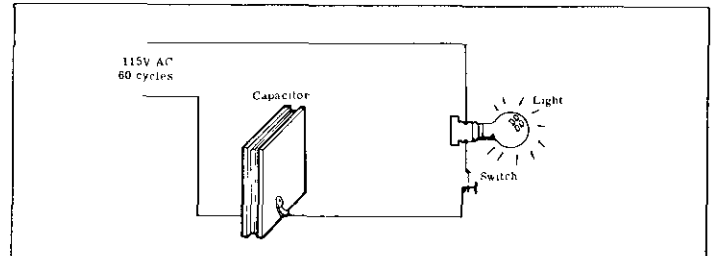

Figure 18. Schematic of a capacitor in an a-c circuit.

Now let us connect this capacitor to an a-c source, as shown in Figure 18. Because the polarity of the current reverses each  $1/2$  cycle, the plates of this capacitor are charged, discharged, charged in the opposite direction and discharged—60 times each second. Although the electric current does not flow through the capacitor, electric current does flow through the electric lamp shown, and the lamp consumes electric power.

The practical unit for the capacitor is the microfarad. In the example shown, the capacitor is rated at 5 microfarads.

By controlling the flow of a-c current to the load, the capacitor acts as a resistance to the flow of alternating current. The type of resistance it offers to a-c is called capacitive reactance. As capacitance (in microfarads) increases, capacitive reactance decreases, and vice versa. Thus if the capacitance were raised to 10 microfarads, or double its rating, the capacitive reactance (measured in ohms) would decrease, and more current would flow.

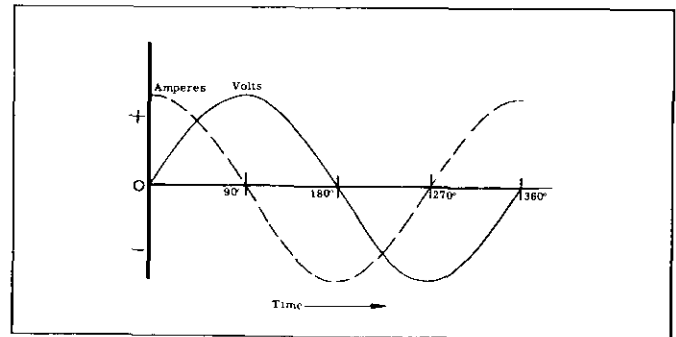

Figure 19. Relationship of voltage and current in a pure capacitance circuit. Current leads voltage by  $90^\circ$ .

An important property of a capacitor in an a-c circuit is the fact that the current "leads" the voltage by  $90^\circ$ , Figure 19. Recall that inductive loads caused the current to lag behind the voltage with resulting low "power factor" and wattless current. By combining capacitive loads with inductive loads, current lead and lag may be made to compensate so that the current and voltage are more nearly brought "into step," and the out-of-step wattless current will be reduced.

The practical use of capacitors you will encounter will be "starting capacitors" and "running capacitors" on single-phase motors.

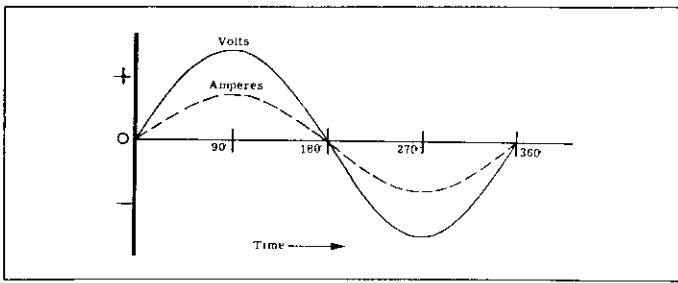
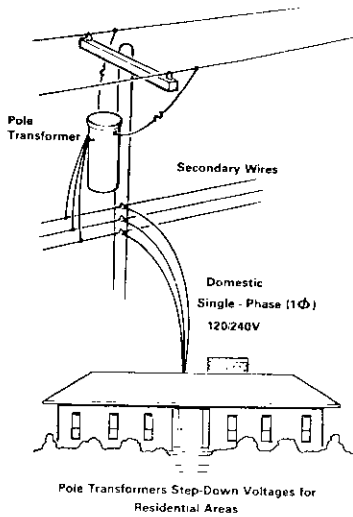

Figure 20. Relationship of voltage and current in a pure resistance load. Current and voltage are in phase.

Motor design theory is beyond the scope of this course, but we can point out that starting capacitors establish a "rotating field" to make the motor start. "Running capacitors" used on certain types of hermetic refrigeration compressor motors reduce the "wattless current" in the motor while it is running. On a pure resistance load with alternating current, the current remains "in phase" with the voltage, Figure 20.

**POWER SUPPLY TO STRUCTURE**

The mechanical rotation needed to cause relative motion between a magnetic field and electrical conductors is produced by turbines which are driven by hydropower or by gas, oil or coal fired steam. Large step-up transformers are fed this induced electricity. For this example, the step-up transformer is fed 18,000 volts, generated by the turbines. This is raised to 120,000 volts or the amount of voltage required by the system. Transmission line losses are less at high voltages.



After the voltage has been stepped up in the transformer, a mat, defined as a type of shipping department, is necessary. Through the maze of equipment at a power station, the electricity travels to the customers along transmission lines. This transmission voltage is now lowered to 4800 volts in a step-down transformer located in the sub-station. From here, distribution lines carry the electricity either directly to industrial customers or to appropriately located step-down transformers. The industrial customers purchase power at a primary rate and do their own stepping down. The other step-down transformers serve a group of industrial or domestic customers.

The 4800 volts from the sub-station are reduced through an a-c network to voltages which can be utilized by individual customers. The voltage step-down is usually accomplished by pole transformers in residential area.

The secondary windings of these power transformers have many configurations. One is the Edison hookup. The step down transformer reduces 4800 volts to 240 volts. This creates two hot (H) legs (L). These are sometimes termed L1 and L2. The secondary of the transformer is center tapped. This leg is called the neutral (N). 240 volts exist between L1 and L2. 120 volts exist between either L1 or L2 and N. The N is electrically grounded at the transformer. Other grounds may exist at the electrical meter and the main circuit panel base.

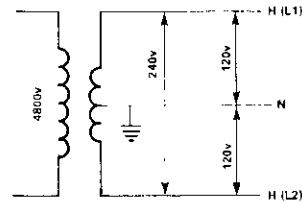

Edison Hookup

After being stepped-down, the power enters the residence through the service entrance which is a meter or fuse box. This electrical service is 240v single phase, three wire. With the heavy electrical loads drawn by appliances such as an electric stove, electric clothes dryer, air conditioner and other powered equipment, the service to most modern houses is sized to carry 100 or 200 amperes and sometimes even more.

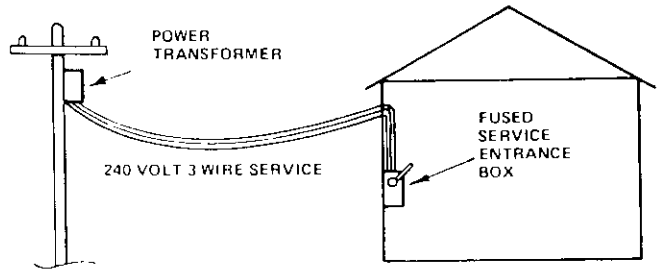

This service is connected to a main fused or circuit breaker box located in the house as close to the electric service entrance as possible. The two hot 240V legs are both fused to the total capacity of the service which is determined by the size of wire entering the house. A third wire is grounded to the power company service transformer located in the vicinity of the house. The voltage between either of the hot 240V legs to this grounded conductor is 120 volts.

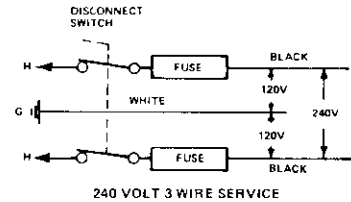

240 VOLT 3 WIRE SERVICE

Within the Main Box the circuits are broken down into a series of branch circuits. The branch 240V circuits are to serve such major appliances as the air conditioner, electric range and electric clothes dryer. These are in turn fused in both legs for the current the appliance will draw. The wire connecting these circuits to the appliance must be heavy enough to carry the load determined by the size of the fuse.

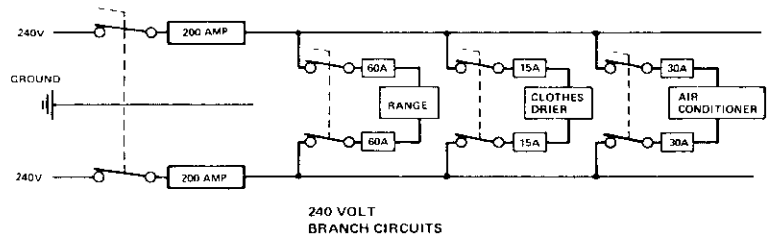

240 VOLT BRANCH CIRCUITS



The Main Box may have reset Circuit Breakers or Fuses.

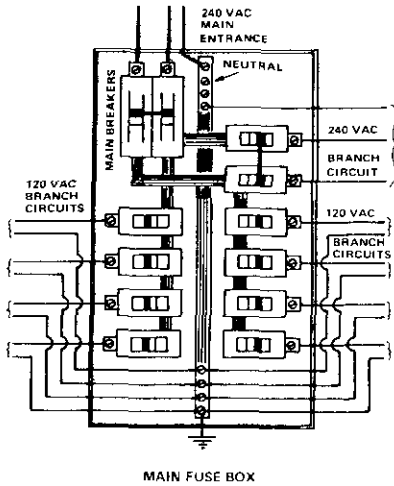

The 120V circuits are also broken down into fused branches. These are generally fused for 15 or 20 amperes. Each branch is fused in the hot leg only. The branches from each side of the 240V legs are taken off to balance the loads insofar as possible. Each branch serves as specific area of the house or appliance as governed by the local electrical code. One branch supplies power to the heating unit and/or cooling unit.

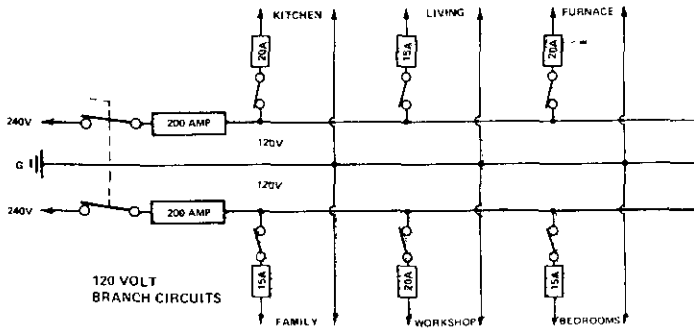

Wires are run from the branch circuit which serves the furnace to a fused switch box located in the vicinity of the furnace. The purpose of this fused switch is to provide a convenient means for disconnecting the furnace both for service purposes and as a safety means in case of malfunction of the equipment. The fuse in this box must be sized in accordance with the maximum amperage stated on the AGA plate on gas furnaces. This plate is permanently affixed to the front panel of the furnace. For most residential furnaces the load is stated as "12 amps or less" which allows the fuse size to be no more than 15 amperes.

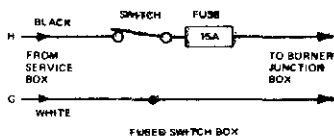

A black 120 volt wire and white ground wire are run from the fused switch box to a set of terminals or pig-tail connections provided within the furnace. These are located within a junction box or control box located in the furnace and the connection is called out on the furnace wiring diagram.

When these connections have been made, the field-installed line voltage wiring is complete. From this point the remainder of the 120V circuits have been factory-installed and are already connected within the furnace itself.

All switching within the furnace line voltage circuits is done in the hot 120V leg. The reason is that switching, if done in the ground leg, could result in an unsafe grounding fault. See diagram.

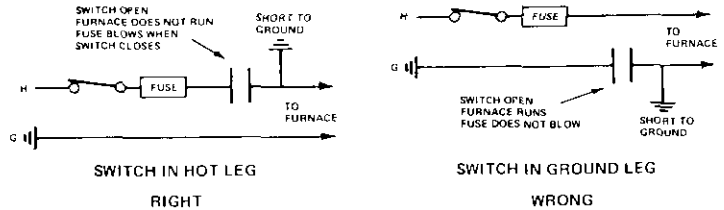

The furnace blower motor, which is always line voltage, is the first electrical component wired into the system. When the disconnect switch is placed in the "on" position, a complete circuit is made and the blower motor is energized. This motor, in turn, drives the blower which delivers air through the furnace and duct system. When the switch is placed in the "off" position, the circuit is not complete and the blower motor will not run. Air flow in the system will stop. A 240V fused disconnect breaks each hot leg simultaneously. The circuit breakers perform the same safety function.

### CONTROL CIRCUIT ELECTRICITY

Our modern world of automatic machines and instruments has been made possible in large part by man's ability to understand and apply electricity. A basic knowledge of electricity, how it works, how it is measured, and how it can be applied and controlled, will be of great value to you.

Since, as a technician you will be required to work with these electrical circuits, the more you know about electricity the more competent you will be. This lesson consists of a main section covering complete control circuits and an appendix, covering basic principles. Your instructor will help you to concentrate on those parts of the lesson which will be of the most value to you.

For more complete information, you should refer to textbooks on electricity and electrical engineering, which are available in most libraries.

Many different symbols are used to denote electrical components. Those shown in last two pages have been recommended by the Refrigeration Service Engineers Society (RSES) Educational Committee for use on circuit diagrams for heating and air conditioning equipment.

Many types of wiring diagrams can be used to show circuits for heating and cooling systems. It is important to be familiar with some of these diagrams in order to understand how all the controls are interrelated within a particular circuit.

### HEATING SYSTEM

The simplest system that you will find in the field, is a forced-air heating system with a direct drive or indirect drive blower. Figure 21 shows a typical wiring diagram for a heating system with a pilot safety switch and an upper limit control used on counterflow furnaces. The same wiring diagram would be valid for a heating unit with an automatic pilot valve, and the switch shown in Figure 21 would be omitted.

There are two basic circuits in this system: A high-voltage circuit and a low-voltage circuit. In most heating systems, the high-voltage circuit operates the furnace blower motor and component controls. The low-voltage circuit energizes the thermostat and burner controls.

**HIGH VOLTAGE CIRCUIT** - The controls and components connected to the high voltage circuit are the blower motor, fan control, and primary side of the transformer. Also, an ON-OFF switch is usually provided.

The blower motor is energized when the fan control senses heat from the furnace heat exchanger, and the fan control switch closes. The blower motor and fan control switch are connected in series.

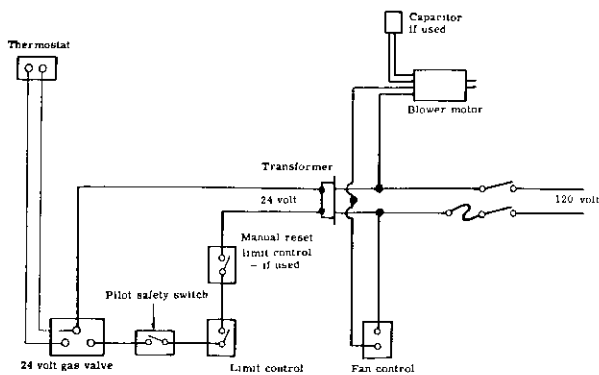

Figure 21. Simplified sketch of heating system and operating controls.

**LOW-VOLTAGE CIRCUIT** - The low-voltage circuit (generally 24 volts) is energized from the secondary winding of the transformer. There are generally two, three, or four switch-type automatic controls connected in series in the 24-volt circuit: the room thermostat; the high-temperature limit control; the pilot safety switch (may not be included); and a manual reset limit control (for use in counterflow furnaces). In order for the gas valve to be energized by the transformer, all switches in the circuit must be in the closed position. In a properly functioning system, only the thermostat switch opens and closes. All other switches remain closed.

With a drop in room temperature, the thermostat switch closes, completing the circuit and energizing the gas valve, causing it to open. If an overheating occurs while the gas valve is open, the limit-control switch will open, thus breaking the circuit and allowing the gas valve to close. In a counterflow furnace, the upper limit switch may also function to break the 24-volt circuit, thus de-energizing the gas valve. And, if the pilot burner does not function properly, the pilot safety switch will open, breaking the low voltage circuit.

#### COOLING SYSTEM

The circuit shown in Figure 22 is a simplified sketch of a very simple cooling system consisting of a low voltage thermostat and the refrigeration compressor energized by a high voltage line. In this sketch, the compressor is started by a relay or motor contactor pulled in by a coil in the 24-volt circuit which is energized when the thermostat contacts close. For clarity, the contactor coil is separated for the two circuits, so that the components in each circuit can be clearly visualized.

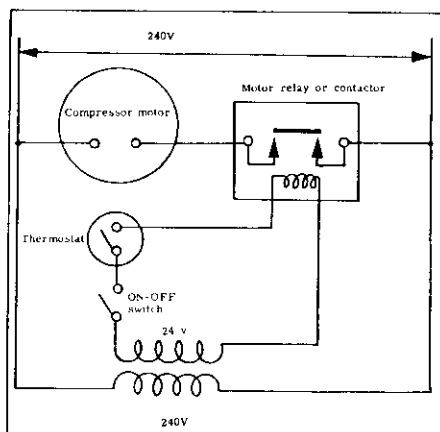

Figure 22. Simplified basic cooling system and operating controls.

Figure 23 is a different type of circuit diagram, but still in the simplified form. This diagram includes the blower motor for circulating cooling air, and an anti-cipating thermostat equipped with a blower motor switch to allow operation of the blower on automatic or manual control. For normal operation, the blower switch is on automatic, and so is the thermostat or season switch. Thus the blower will run only if the thermostat contacts close and call for operation of the compressor. For constant air circulation, the season switch is kept in the AUTO position and the blower switch is in the "ON" position. With this arrangement, the blower circulates air continuously, and the compressor runs only when the thermostat completes the circuit for the compressor motor contactor on a rise in room temperature, thus calling for cooling.

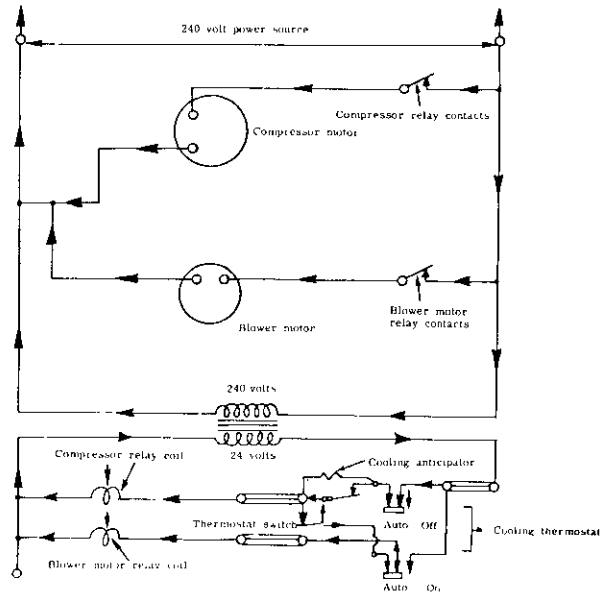

Figure 23. "Unfolded" schematic circuit diagram of cooling system with manual-automatic thermostat.

Not shown in these circuits are the auxiliary controls and motors that constitute a complete cooling system. This would include a motor to power the condenser fan, motor protective devices to guard against motor overload and/or overheating. In addition the compressor motor would be protected by switches that detect high and low pressure in the refrigerant.

The condenser fan motor is often connected in series with the compressor motor through the same contactor, and therefore operates only when the compressor motor is energized. The pressure controls can also be wired in series with the compressor motor circuit, or if low voltage controls are used (24 volts) they can be wired in series with the thermostat switch.

This is an "unfolded" diagram. That is, the high voltage and low voltage circuits are shown separately so that controls (relays for example) with 24 and 240 lines are shown as split units in this schematic.

#### HEATING AND COOLING

Finally, the third type of wiring diagram that will be encountered will be the type that shows the actual wiring, binding posts, junction boxes, control panels, and other electrical features. A typical diagram for a combination heating and cooling unit is shown in Figure 24.

In this circuit, the condenser fan motor and the compressor motor in addition to the various capacitors and overload protectors are in the high-voltage circuit. On the heating side of the equipment, only the furnace blower motor and the plenum fan switch are in the high-voltage circuit. All other controls for both heating and cooling are in the low-voltage circuit.

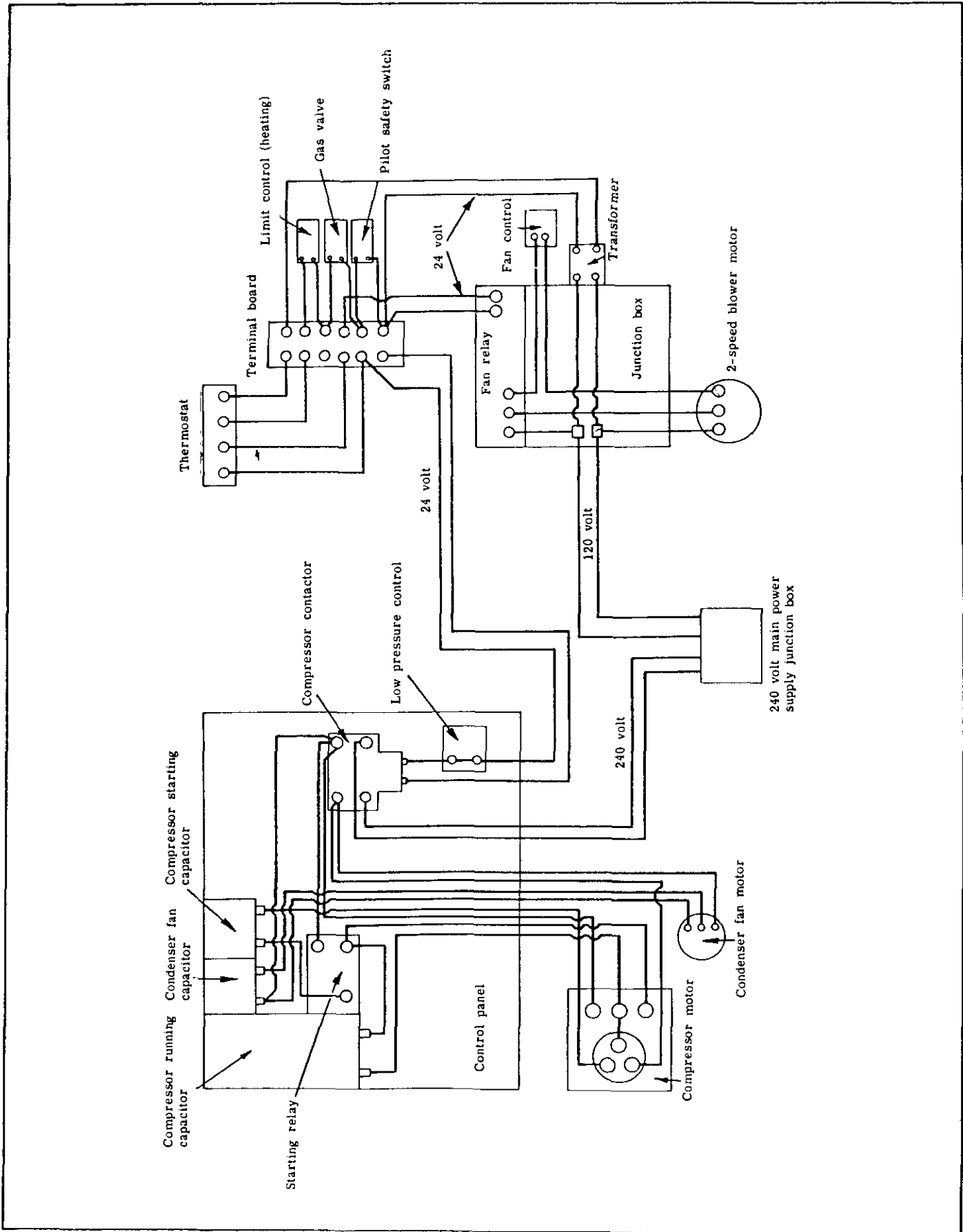

Fig. 24, Complete "field" wiring diagram for heating and cooling system.

**Low Voltage Circuit** - The 24-volt transformer is powered by a primary winding which is connected across a 120 volt a-c line. The 24-volt circuit operates a motor contactor, which is energized when the thermostat calls for cooling, and its contacts close to complete the circuit. The motor contactor pulls in a switch which closes to energize the high-voltage circuit (generally 240 volts for cooling compressors). Most residential units are also equipped with a condenser fan motor which operates on 120 volts. A relay in the 24-volt line operates this motor too.

**High Voltage Circuit** - The following controls are generally found in the high-voltage circuit in a residential cooling system: Compressor contactor, compressor starting relay, compressor motor, condenser fan motor, starting relay for condenser fan motor, high pressure limit control, low pressure limit control. In addition, the motors may have built-in protective devices. The compressor motor is generally equipped with an overload control, and the condenser fan motor with a temperature limit control.

**PARTS OF AN ELECTRICAL CIRCUIT**

**SWITCHES**

A switch is a device that opens or closes an electrical circuit. A switch has at least two positions: open and closed. When a switch is open, no electricity flows through it. When a switch is closed, electricity flows through the circuit. When the switch is closed, the circuit is said to be energized.

In order to perform service on a load, one must discontinue the electron flow to the load for safety purposes. The load is said to be isolated. Switches are used to isolate loads. For this reason, switches are always located in the hot (H) leg of the circuit, never in the neutral (N) leg. When the switch is opened, electrons will not flow to the load, allowing service to be performed on the load.

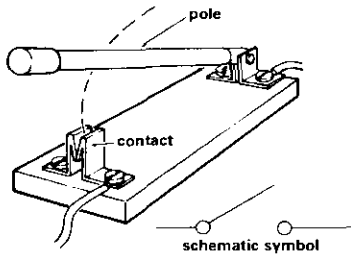

**SPST single pole — single throw**

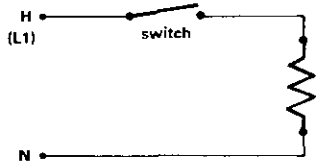

The simplest switch is a single pole, single throw (SPST) switch. This means the switch has one pole (moving mechanism) and one throw (position) that the pole can make contact with.

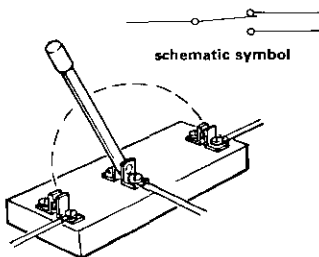

**SPDT single pole — double throw**

Switches are described by the number of poles and throws they have. When a switch is thrown, the pole is moved to another position. Thus, a throw is one position of the pole.

If another contact is added to a SPST switch, the switch becomes a single pole, double throw (SPDT) switch. The pole can be thrown to one of two positions to energize one of two different circuits or loads.

Some household appliances require 240 volts. In this case, two poles each carrying 120 volts are linked mechanically to move together. These poles are connected to two separate hot legs called L1 and L2. The poles make and break at the same time. This type of switch is called a double pole, single throw (DPST) switch. A common use of a double pole, single throw switch is the disconnect switch on a window air conditioner.

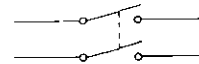

**DPST Switch — schematic symbol**

If another throw is added to the DPST switch, it becomes a double pole, double throw (DPDT) switch. Now the poles can make contact in two positions.

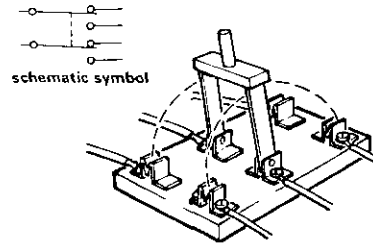

**DPDT double pole — double throw**

Disconnect switches should always be placed in the hot leg of a circuit. The disconnect switch is the first electrical device in the path from the source. All loads in the circuit can be de-energized by throwing the disconnect switch. Only the contacts of the switch will have electrical potential when the switch is open.

If a switch has a single pole that can be thrown to make contact with any one of a number of contacts, the switch is called a rotary switch. Each throw energizes a separate circuit or load. A typical rotary switch is the channel selector or dial on a television set.

**CIRCUIT PROTECTORS**

Excessive current flowing through a circuit can be dangerous. It can also damage components. Some point in the circuit could eventually become so hot that a fire could result. To prevent this, something must be placed in the circuit to sense excessive current and open the circuit before danger arises. This protection is provided by circuit protectors. There are two major types of circuit protectors: fuses and circuit breakers.

**FUSES**

A fuse is used in a circuit to protect against wiring overloads. An overload occurs whenever there is too much current for the size of the wire. This could happen if too many loads are plugged into the same circuit.

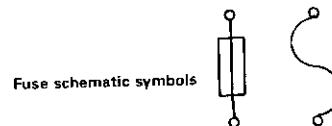

**Fuse schematic symbols**

Another example of an overload would be if a piece of metal fell across the bare wires of a circuit. This may also be called a "short". A short could also occur if there is a malfunction in the load such as a motor that burns out causing a direct short across the motor windings. In the case of a short circuit, the current takes the path of least resistance, which would be the metal bar or the shorted motor windings. Electrons would surge through the metal bar or shorted motor windings. Since the wires in this circuit are sized for the operating amperage of the load, they are much too small to handle the high amperage caused by the short.

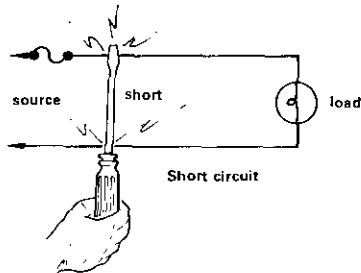

A short could cause the wire to heat up to a point where a fire is possible due to the combustible materials that usually surround electrical wiring. A short would also occur if bare wires in a circuit came in contact and bypassed the loads in the circuit.

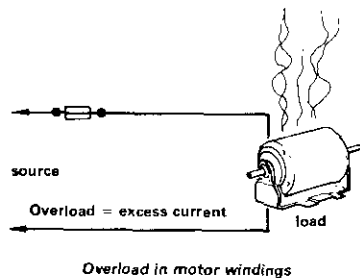

The simplest fuse is a metal conductor with a low melting point. When excessive current flows through the circuit, the fuse begins to heat up. When the temperature reaches the melting point, the conductor melts (blows), breaking the circuit. The wiring in the circuit has not reached a dangerous temperature and hazard is averted.

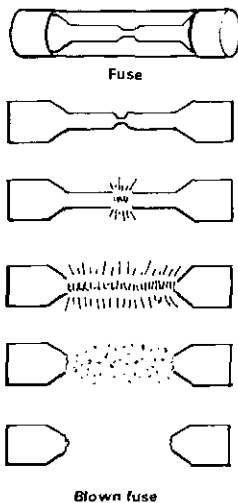

Fuses are sized according to the amount of amperage they will carry without breaking the circuit. A 15 amp fuse will conduct up to 15 amperes. If too much load is plugged into the circuit or a short drawing more than 15 amps occurs, the fuse will blow. Fuses come in many

different amperage ratings. Never use a larger fuse than the circuit is rated for. An oversized fuse does not protect a circuit. Most fuses must be replaced when they burn out...little expense for the damage they prevent.

#### TIME-DELAY FUSES

Time-delay fuses are designed and built to withstand the initial current load caused by the starting of electric motors. A motor will take several seconds to come up to speed on starting. This start takes more current than when the motor is running full speed. If a fuse was sized for motor start-up, it would be too large to protect the wire in the circuit. If the fuse was sized properly for the wiring in the circuit, it would blow each time the motor started.

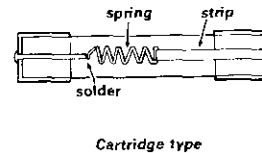

A time-delay fuse has a metal fuse strip that has one end attached to the case of the fuse. The other end is attached to a pin held under spring tension. The end of the pin is embedded in solder. If the solder gets hot enough to melt, the pin pulls out of the solder, breaking the circuit. This solder will withstand a momentary overload (i.e. motor start-up) without melting. If the heat from the overload is continuous, the solder melts and breaks the circuit. This might take several seconds. If a direct short should occur, the metal fuse strip melts instantly and opens the circuit.

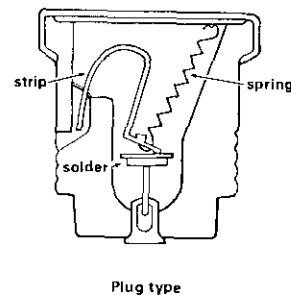

#### CIRCUIT BREAKER

The other type of circuit protector is the circuit breaker. Some circuit breakers look much like a switch. They usually have a lever with "on" and "off" positions. When in the "on" position, current flows through a thermal device within the breaker. If excessive current passes through this device, it heats up. If the thermal element gets too hot, it "trips" the breaker. When the breaker is tripped, the lever is in the "off" position and the circuit is open. After the thermal element has cooled sufficiently, the breaker can be manually reset to close the circuit again. (Be sure the short or overload has been corrected.)

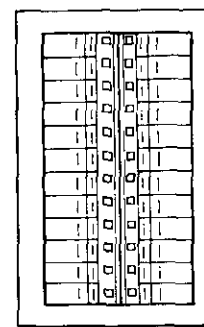
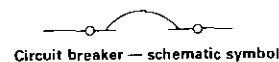

Circuit breaker panel

Another type of circuit breaker looks like a regular strip fuse with a button protruding from the top. When this breaker trips, it can be manually reset by pressing the button. Whenever a fuse blows or a circuit breaker trips, the cause should be determined and corrected before replacing or resetting.

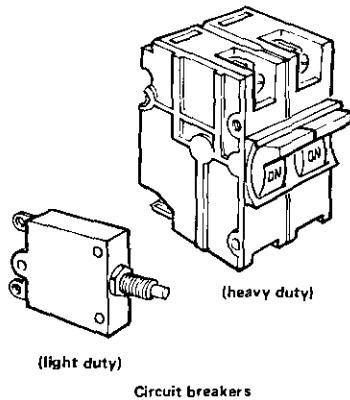

In a 120V household circuit, fuses or circuit breakers are always placed in the hot leg of the circuit. In a 240V circuit, both hot legs are fused.

#### ELECTRICALLY ACTUATED SWITCHES

Heating and cooling equipment efficiency and safety are enhanced with the usage of relays. Relays introduce considerable electrical circuit flexibility. A relay consists of an electrical actuating mechanism and one set or multiple sets of contacts. Whenever a relay is used in a circuit, the voltage rating and amperage rating of both electrical actuator and contacts should be noted. The relay is sometimes termed an electrically actuated switch.

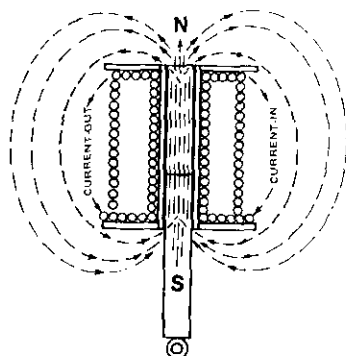

COIL AND PLUNGER

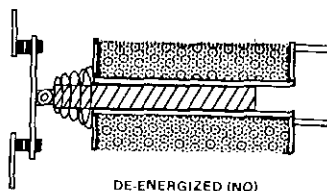

DE-ENERGIZED (NO)

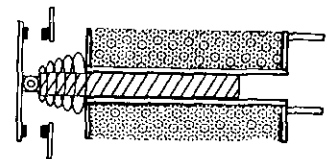

DE-ENERGIZED (NC)

Electrically actuated switches would include all types of relays and solenoids. The actuating mechanism usually consists of an electrical coil and an iron plunger. When the coil is energized, a magnetic field is created around the coil which will attract the iron plunger and draw it up into the field. When the coil is de-energized, the plunger will return to its original position either by gravity or spring action.

A set of contacts at the end of the plunger will make or break as the plunger moves up and down providing the switching action needed. The original position of the contacts can be either "made" (closed) or "open". If they are closed when the coil is de-energized, the switch is said to be (NC) normally closed and the symbol for this on a diagram is shown  $\text{---} \text{---} \text{---}$ . If the original position of the contacts is such that they are open when the coil is de-energized, they are said to be (NO) normally open with the symbol  $\text{---} \text{---} \text{---}$ .

Note that the coil will frequently be in the low voltage circuit while the contacts actuated by it are in the line voltage circuit. These two circuits are totally independent of each other. Line voltage, therefore, can be controlled by the coil in the low voltage circuit.

The switching action of an electrically actuated switch can be single-pole single-throw, single-pole double-throw or any of the other basic actions.

#### SOLENOID

A solenoid consists of a coil of conductor wire and a movable iron rod. A solenoid might also be called an electromagnet.

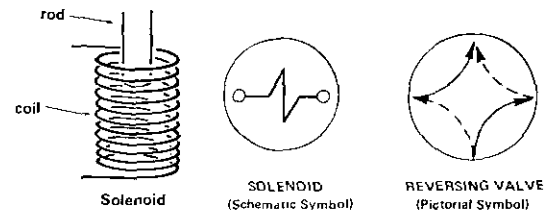

The tip of the iron rod is positioned just inside the entrance of the coil opening. When the coil is electrically energized, the resulting magnetic field of the coil pulls the iron rod into the center of the coil. The iron rod will remain in this position until the coil is de-energized. Normally, there is a spring attached to the rod that returns it to the de-energized position.

#### SOLENOID OR GAS VALVE

A variation of this type of switch can be found in a Solenoid or Gas Valve where the low voltage coil would pull the plunger into its magnetic field and open or close a valve rather than an electrical contact. The valve would then either pass or oppose the flow of gas or liquid through the line so this switch becomes a mechanical switch controlling flow rather than an electrical one, controlling line voltage.

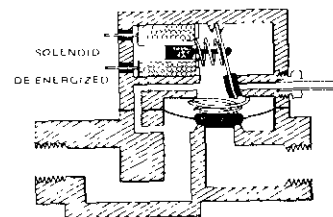

GAS VALVE (Schematic Symbol)

## REVERSING VALVE

This same principle is used in the reversing valve of a heat pump. As the coil is energized, it moves the pilot circuit valve in the heat pump to the opposite position which in turn changes the main valve in the heat pump, reversing the flow of refrigerant from the indoor to the outdoor coil or vice versa.

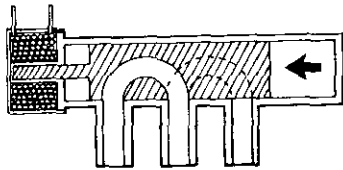

REVERSING VALVE  
(Solenoid Operated)

## RELAYS

Electrical relays utilize the principle of the electro-magnet. A relay consists of a coil of wire and an iron core located near a movable metal armature. The armature has an electrical contact on one end. Another contact is stationary. When the relay becomes electrically energized, the iron core becomes magnetized and attracts the metal armature. When the armature moves to the magnet, the armature contact closes against the stationary contact. When the relay is de-energized, the core is de-magnetized. A spring returns the armature to its original position and the contacts separate.

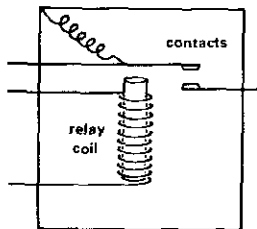

Relay

A relay is used when it is necessary to control an electrical device from another location. For instance, a large electrical motor (drawing many amps) is located in the basement of a building. To save inconvenient trips to the basement, motor operation is to be controlled from the fourth floor. To do this, high voltage (also called line voltage) wires would have to be used to connect the motor in the basement with the switch on the fourth floor. This wiring is very cumbersome and expensive.

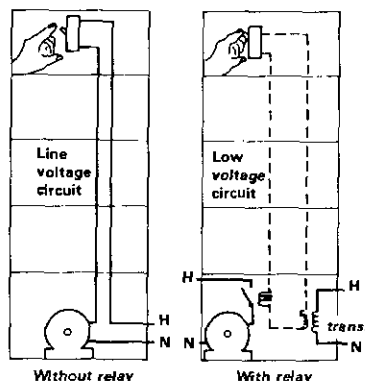

The electrical relay solves the problem shown in the following manner. The low voltage circuit connects the switch on the fourth floor with the relay in the basement. The low voltage circuit is usually 24V. Thus, smaller wiring can be run from the fourth floor to the basement. When the fourth floor switch is "on", 24V electricity

energizes the relay and the relay's contacts close. The closed set of relay contacts completes the high voltage or line voltage circuit to the motor. Less line voltage wire is now needed to run the motor.

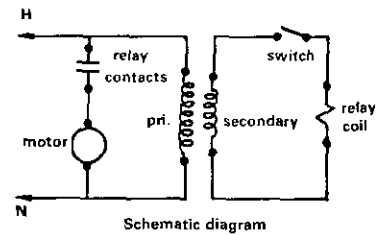

There are several types of relays. The relay described in the previous examples is used to close or complete a circuit. This type of relay contains a set of normally open (NO) contacts. This means the contacts are open when the relay is not energized and closed when the relay is energized.

Another type of relay is used to open a circuit. This relay contains a set of normally closed contacts (NC). This means the contacts are closed when the relay is not energized and opened when the relay is energized.

Some relays are capable of opening one circuit and closing another circuit at the same time. This can be done with the use of a single pole, double throw switch (SPDT). A SPDT switch has one set of normally open contacts and one set of normally closed contacts. When the coil is not energized, the first circuit's contacts are closed and the second circuit's contacts are open. When the coil is energized, the first circuit's contacts will open and the second circuit's contacts will close.

A typical relay capable of opening and closing several circuits is shown below.

Relays are produced in a variety of shapes and sizes, with many different voltage and current-carrying capabilities. Although the variations are many, basic operating principles are the same.

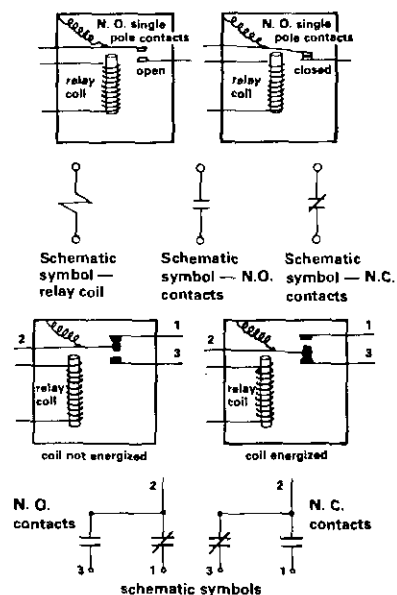

## POTENTIAL RELAY

Another electrically operated switch is a Potential Relay. This device has a set of (NC) contacts and a coil; both are in the line voltage circuit. As the compressor comes up to speed, there is a voltage build-up across the coil in excess of the applied line voltage. This is because the compressor start windings act as a generator building voltage across the coil. When the voltage is great enough (around 400 volts), the coil picks up and opens the switch, taking the start capacitor out of the circuit.

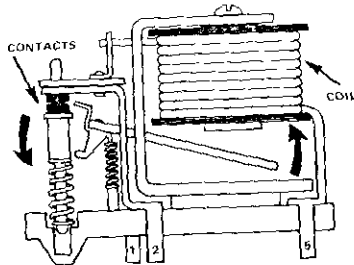

POTENTIAL RELAY  
SINGLE POLE SINGLE THROW  
(NC) DOUBLE CONTACTS

As long as the compressor is running, this voltage will be maintained across the coil, and the contacts will remain open. When the compressor stops, the voltage drops and the coil will be de-energized, closing the switch.

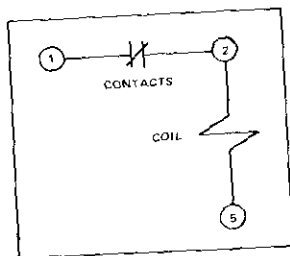

POTENTIAL RELAY  
(Schematic Symbol)

## CONTACTORS

A contactor is an electromagnetic device which makes and breaks the power to either a compressor or a large motor. Although a contactor looks different than a control relay, both operate the same. Both incorporate a magnetic coil which is powered by a control circuit, and both contain a set of contacts to make or break a desired electrical circuit. These two circuits are electrically separate. The real difference is in size and ability to carry increased current. Contactors use heavier contacts and a larger coil to create enough magnetism to move the switch. Relays generally do not control power consuming devices except motors and solenoids which draw less than 2 amps.

Contactors that are approved for special applications are referred to as "definite purpose contactors." A compressor contactor is a definite purpose contactor. Since this contactor is subjected to frequent recy- ciling, the contacts are enlarged for satisfactory heat dissipation to prevent contactor overheating. In addition, the contacts are made of silver cadmium or a silver alloy. This material is designed to provide low contact resistance, clean arc-breaking capability and antiwelding characteristics.

The design of a definite purpose contactor should equal the life of the equipment, providing it operates under normal conditions. Contactors are often replaced needlessly because the service man is not aware of normal contact wear. Before the contactor is condemned, any carbon that forms on the contact surface should be wiped away.

However, if the contactor is subjected to abnormal operating conditions, carefully analyze the condition of the contactor before allowing it to remain in the circuit. The correlation between compressor and contactor failures is very close. A compressor failure could ruin a contactor while a contactor failure could cause a compressor burnout.

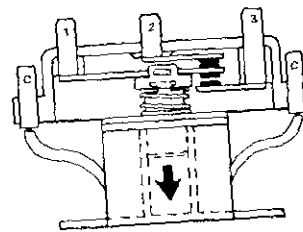

DOUBLE POLE CONTACTOR

Any contact hesitation or contact bounce results in detrimental arcing that produces excessive heat. There are a number of causes.

1. The snapping action of the releasing force is fundamental to the controls longevity. Turn the power off to the machine and push in on the armature. Release the armature to test the spring's tension. It should snap back into place. If the spring has lost its resiliency, the contactor should be replaced immediately.
2. If the control circuit is over voltaged, continuous operation can cause both coil failures and contact bounce. Contact bounce burns contact tips and causes welding. The added shock from the increased magnetic pull may also cause mechanical damage to the contactor. Check the secondary voltage of the transformer and correct the condition if necessary. On multi-tap transformers, make sure the correct tap is used.
3. Short cycling on units without timed off controls or compressor interlocks can also cause hot arcs. Vibrations at the thermostat or contactor in addition to rapid cycling of a safety control can cause short cycling.

Excessive current will produce heat which could damage the contactor. An electrically shorted motor, lightning, a power surge, etc. could create such a current. The generated heat may deteriorate the coil or affect the spring resiliency in addition to possibly damaging the contacts.

Because of the damage inflicted by heat during a compressor burnout, it is advisable to replace the contactor as well as the compressor. Although the control may appear normal, the heat could have damaged the coil or the spring. The danger is that the contactor may well shut in the near future and cause another compressor burnout.

Generally, the price of a contactor is about 10% the cost of the compressor. When the added expense of a compressor and system cleanup are considered, the price of a contactor is small. The possible savings in practicing this preventive tactic increases as the size of the compressor increases.

## SINGLE PHASING

Basically, single phasing is when current flows through two phases while no current flows through the open phase. This causes increased amperage draw at the two phases which overheats the motor. Single phasing can cause a motor failure even though the motor protection may trip to open the control circuit. If single phasing occurs, the motor may stall unless lightly loaded, and once stopped, it will not start resulting in locked rotor amps. An amp meter can readily determine a single phase condition.

If the motor is single phasing, inspect the contactor closely to determine if it is the cause.



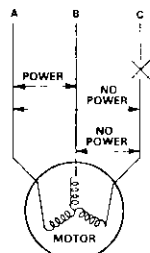
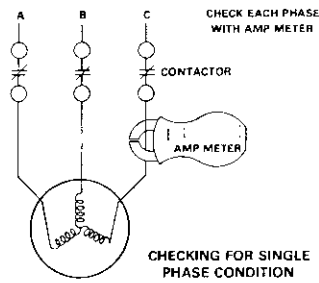

SIMPLE SINGLE PHASE FAULT IN LOAD CIRCUIT

**CONTACTOR MAINTENANCE TIPS**

1. Never use lubricant sprays or solvents on the contactor. The excess runs into the sliding mechanism. The lubricant film on surfaces captures dust and metal particles. Contact resistance and friction can increase, and the entrapped particles may eventually interfere with the armature travel. This could cause an increase in arc duration and possible contact welding.

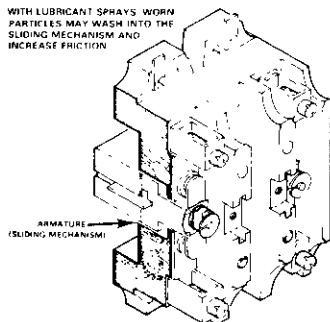

NEVER USE LUBRICANT SPRAYS OR SOLVENTS

2. Never force a contactor closed while power is on. You may damage the contacts. In addition, never hold a compressor contactor in to run the equipment. A safety control may have opened the control circuit and continued operation may damage the compressor.
3. The contact points should never be filled or dressed.
4. Always keep the relay cover in place as well as the unit access panel. Dirt and dust will collect on the contact surface and can quickly burn the contacts. Without the unit panels in place, other adverse conditions such as high humidity or moisture could also damage the control.
5. If the contactor is taken apart for any reason, extreme care should be taken when reassembling it. Many of the contactors that are returned for credit have been reassembled wrong or have parts missing.
6. Carefully check the condition of contactor when making a cooling service call. Closely observe the contactor coil for cracking, swelling or bubbling. Terminal discoloration indicates poor or loose connections.
7. Insects may nest in and around the contactor since it is warm (especially in the spring). Clean if necessary.

**THERMOCOUPLE**

A thermocouple is another type of heat actuated device. The heat from the pilot flame produces a small amount of electrical current which in turn energizes a coil which opens a valve in the safety circuit. The flow of current "proves" that the pilot is lit and it is safe to open the main gas valve.

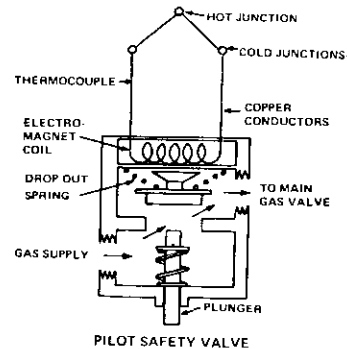

**TIME DELAY RELAY**

A further variation of a heat actuated relay would be a "Time Delay" relay, such as used on an electric furnace. This relay has a set of normally open contacts in the line circuit, actuated by a coil in the control circuit. The control circuit contains a resistance which heats up when the circuit is energized. At a pre-set point the heat generated actuates a bi-metal which closes the switch to the next control circuit. The time required for the bi-metal to close is about 30 or 45 seconds which effectively delays bringing on the element for this amount of time.

This can also operate in reverse and hold the element on the line for some time period after the coil is de-energized.

Some heat actuated switches are designed so that the heat generated by electrical current passing through the wires will activate the switch if it becomes excessive. In "Basic Electricity" it was determined that heat is produced by friction due to the resistance of the wire to the flow of electrons. If the cross sectional area of the wire is too small for the amount of electrons flowing through it, it will heat up. This is why the size of the wire is important and must be matched to the amount of current it must carry. However, in the case of a "short," the electrons bypass the load (resistance) and many more than expected will flow through the wire, causing it to heat up rapidly. Thus a "fuse" is nothing more than a heat actuated switch.

**AMPACITY**

Ampacity is an electrical rating used to properly size conductors to electrical equipment. This rating is based upon (1) type of conductor, (2) size of conductor, and (3) kind of insulation used on conductors.

Manufacturers are now putting ampacity ratings on the nameplate of their electrical equipment. When selecting wire size for equipment, take the ampacity rating shown on the equipment and use the ampacity chart found in the National Electric Code (NEC) manual.

The NEC manual will show the various wire sizes and configurations to match the equipment ampacity rating.

The ampacity rating is equivalent to 125 percent of the actual amperage draw of the electrical component. For example, if an electric heater draws 5 amps, the ampacity can be calculated in the following manner:

$$5 \text{ amps} \times 125\% = 6.25 \text{ ampacity}$$

The extra 25% is to make sure the wiring will not catch fire in the event of an electrical overload. If the circuit is properly fused, an overload will blow the fuse before the wire gets hot.

**COMMON LOADS**

Common loads that are encountered in residential and commercial HVAC heating and cooling equipment can be categorized into three groups: resistive loads, inductive loads and capacitive loads. The skilled service person must be able to use electrical test equipment to isolate the electrical condition of a load. Determining whether a load is open, shorted, or good is impossible without an understanding of the electrical information obtained from testing equipment.

Learning this troubleshooting technique has several advantages. This knowledge assures that only faulty loads are replaced. Also, communicating equipment problems to a service manager can be easier with this troubleshooting knowledge.

**RESISTIVE LOADS**

Examples of resistive loads are: electric heat elements and heaters on thermally actuated relays. A voltage check cannot determine the exact electrical condition of the component. If the load is electrically open, a potential difference will still exist across the load, and this will be indicated on a V-O-M meter as a voltage reading. To check out all resistive loads with confidence, make an Ohm's check. Remember when conducting an Ohm's (continuity) check, turn the power off; the load must be isolated from the circuit, and the V-O-M meter must be zeroed.

The symbol for resistive loads is . The circles at each end of the symbol indicates electrical test points or terminals. The following illustrations summarize these electrical checks on resistive loads.

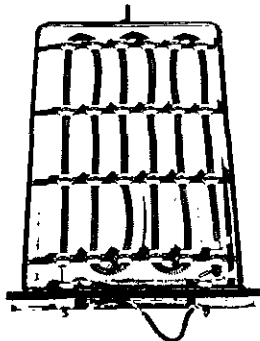

Electric Heat Element

**INDUCTIVE LOADS**

Examples of inductive loads are: relay solenoids, transformers, and blower motors. The operation of all inductive loads is based on the principle of induction. Induction is defined as the relative motion between a conductor and a magnetic field. A corollary to this principle is the fact that whenever an electron flow exists in a conductor, a magnetic field surrounds the conductor.

A transformer is a good example of an inductive load.

schematic symbol

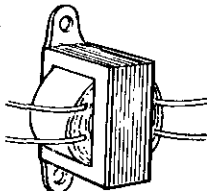

Transformer

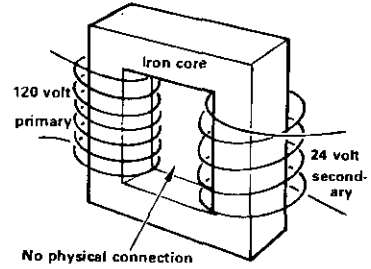

Step-down transformer

Oftentimes, there is a need to increase the amperage capacity in the secondary of a transformer. This is especially true when additional accessory control relays or devices are wired into a 24 volt control circuit. These controls are wired in parallel and consequently the equivalent resistance of the control circuit decreases. This decreased resistance means an increased amperage. The increased amperage capacity of the transformer can be obtained in two ways. A new, higher rated va transformer can be installed. However, it is also possible to wire two 30 va transformers together and have the equivalent of a 60 va transformer. These transformers must be wired in parallel and phased. Phasing can be defined as confirming that all electrons are flowing in the same direction in the controlling circuit. Phasing is also described as polarizing transformers.

**SHORT CIRCUIT PHASING**

Note that the illustration below shows the wrong way to connect transformers in parallel for increased power. The arrows represent the direction of current flow at one instant in the ac cycle. At the instant shown, the polarity of the transformer secondaries are such that the voltages are in series and the current will flow in a loop path from one to the other. The result is the equivalent of a direct short circuit across the secondary terminals of each transformer. One or both transformers will burn out unless protected by replaceable fuses or limited output design. In addition, no current will flow in the circuit.

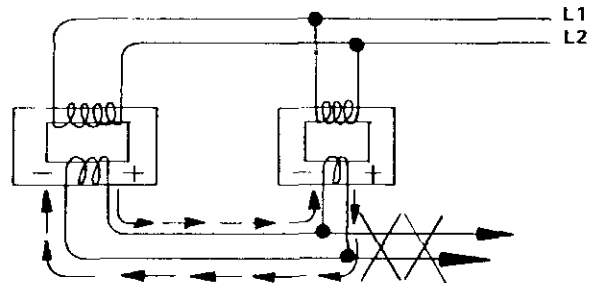

Wrong Way to Connect Transformers in Parallel

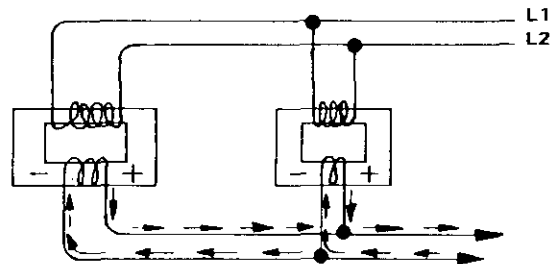

Right Way to Connect Transformers in Parallel

The second illustration shows that the instantaneous polarities of any two inter-connected terminals are the same. As long as the two voltages are approximately equal, the secondary coil current of each transformer will flow only in the wiring to the relay and not through the secondary coil of the other transformer.

Many transformers have color-coded leads to assure proper phasing. The installing contractor or serviceman is assured of proper phasing by merely connecting like colors. An example of color coding follows:

230v Red & Black primary  
Yellow & Blue secondary

120v White & Black primary  
Yellow & Blue secondary

In addition most transformers with screw terminals are coded by coloring - one a brass shading and the other silver or nickel color.

CAUTION: Never short low voltage wiring or substitute any material in place of the fuse.

#### PHASING WITH TWO LOW VOLTAGE CONTROL DEVICES

This problem of phasing occurs when two low voltage control devices (relays, etc.), each with its own low voltage power supply, are used in the same control system. The illustration below shows a single thermostat controlling a heating relay and a cooling relay, each with its own transformer. The circuit is assumed to be open at the thermostat, and no current is flowing.

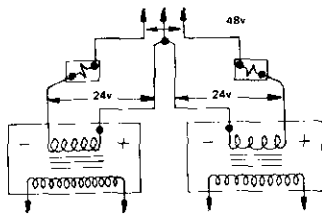

The "+" and "-" signs indicate instantaneous polarities. While voltage measured across either transformer secondary would be 24v, a voltage of 48v exists between the two leads from the relays. Unless the maximum current which can be supplied by the transformers is limited to 1.6 amp, this condition violates the NEC voltage current limits for Class 2 remote control and signal systems. The existence of this situation, can be checked as follows:

1. Leave one of the two thermostat terminals from one relay transformer combination unconnected.
2. Using a voltmeter, check voltage between the unconnected wire and terminal at the relay.
3. A voltage reading noticeably higher than 24v indicates wrong phasing. Reverse the two thermostat wiring connections at the two-wire control relay.

OR

1. Connect thermostat leads at the relays, but not at the thermostat.
2. Using a voltmeter, check voltage at the thermostat between one wire and each of the others in turn.
3. A voltage reading noticeably higher than 24v indicates wrong phasing. Reverse the two thermostat wiring connections at the two-wire control relay.

NOTE: Older models of a control transformer did not have a replaceable fuse. When the transformer is found defective, the entire transformer must be replaced.

NOTE: Transformers wired to three-phase power must be connected to the same phase to make exact phasing of the secondary possible.

#### ELECTRIC MOTORS

Electric motors are another good example of inductive loads. Motors have many uses ranging from power tools to air handlers and compressors.

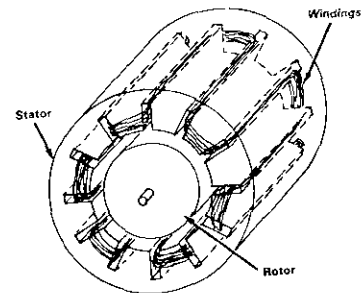

Motor construction consists of a stator which is nothing more than a special configuration of copper wire windings. In the center of these wire windings is a rotor. The rotor is a cylindrical, multiple section magnet with N and S poles. It has a shaft connected to it and set inside the stator, supported by bearings. The stator windings are divided into run windings and start windings. When a motor is energized, the electrical energy fed through the windings sets up magnetic fields by induction. These magnetic fields have poles, much like the N and S poles of a bar magnetic. Since unlike poles attract and like poles repel, forces of attraction and repulsion exist between the stator and rotor; consequently, the rotor begins to spin.

Oftentimes, a capacitor is used in conjunction with a motor.

A capacitor has the ability to store an electrical charge. Following the ac sine wave, the capacitor charges as the voltage builds to a maximum. However, that electrical pressure keeps the capacitor from immediately discharging. As the power source voltage begins to decrease, the capacitor can discharge, after a small delay, and create its own voltage spike. This additional surge of electrons displaces and intensifies the poles of magnetic fields created in the stator.

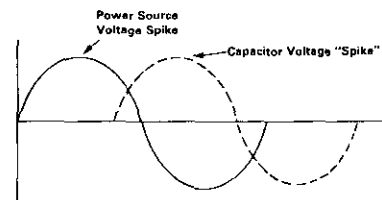

The capacitor causes a phase shift of emf in the start windings. This additional displacement of the magnetic field in the start windings increases the rotational capability of the motor on start-up. Bard uses the split-phase and permanent split capacitor motors.

#### BLOWER MOTORS

The type and size of blower motor installed in a heating and cooling system depend upon the blower load required to deliver the correct amount of air to the system. Because systems vary from one installation to another, the blower speed needs to be adjustable to match the needs of the air distribution system. This speed adjustment may be done either mechanically or electrically.

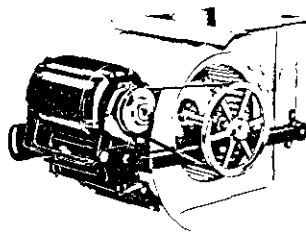

BELT-DRIVE BLOWER

The motor may be connected to the blower by a belt and pulley. In this case, the speed adjustment is accomplished mechanically by a change in the pulleys. This is referred to as a "belt drive blower".

Or, the blower wheel may be mounted directly on the motor shaft. In this case, the motor speed must be changed electrically. This is referred to as a "direct drive blower".

**BELT DRIVE BLOWER MOTORS**

When the load requires a motor of 1/3 hp or less, a SPLIT-PHASE motor is used. The smaller blowers have a low starting load. Therefore, the split-phase motor has enough starting torque to bring it up to speed without any outside assistance to the start winding. When the motor reaches running speed, the starting switch opens, taking the start winding out of the circuit.

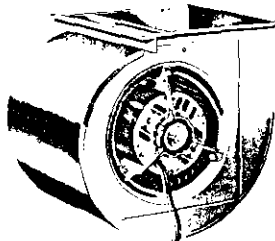

DIRECT-DRIVE BLOWER

A commonly used direct drive blower motor is a PERMANENT SPLIT CAPACITOR motor and is generally referred to as a PSC motor. If a capacitor is used in a start winding circuit, it is simpler if the capacitor can be left in the circuit at all times. The capacitor can remain in the circuit if the correct capacitor is selected for use with the start winding. The capacitor must be able to pass enough current to the start winding to provide adequate torque, but it must not allow so much current that the start winding will overheat while the motor is in operation.

A PSC motor with good starting torque is shown below. This motor is provided with an auxiliary winding which is in series with the capacitor. The auxiliary windings and capacitor are continuously energized while the motor is running. This improves both the starting torque and running efficiency of the motor. The capacitor is usually mounted on the blower housing with the wire leads to the motor. Because the capacitor is energized at all times, no centrifugal switch is necessary.

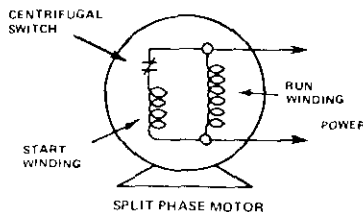

SPLIT PHASE MOTOR

The PSC motor has six poles and a rate of speed of 1050 rpm. However, because of its better starting torque and high running efficiency, it can be used in sizes from 1/8 to 3/4 hp. There, the PSC direct drive motor can be used in all types of heating equipment. It also provides a sufficient quantity of air for cooling.

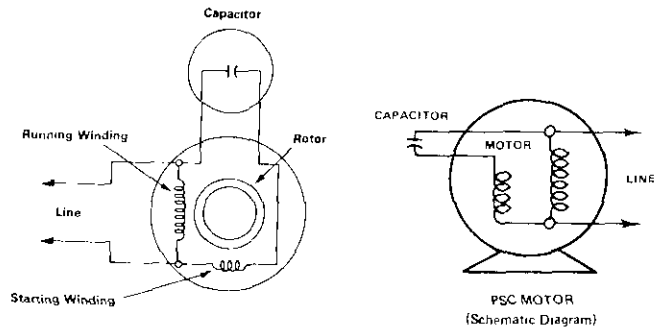

PSC MOTOR (Schematic Diagram)

**PERMANENT-SPLIT CAPACITOR**

**SPEED CONTROLLER**

When these direct drive motors are used, there must be a way of changing the motor speed. This is accomplished by the blower speed being matched to the requirements of the individual heating air distribution system. This also provides a means for changing speeds between heating and cooling since more air is usually required during the cooling season.

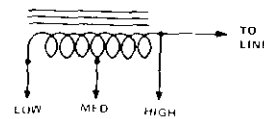

TAPS TO MOTOR

Changing the voltage to the motor windings alters the speeds for the PSC motor. As the voltage is reduced below the 120v line voltage, the motor slows down. The lower the voltage, the slower the motor. The voltage to the motor is regulated by a device called a SPEED CONTROLLER.

The speed controller is an electrical device also called a reactor. It consists of a series of electrical windings around a steel core. These windings are tapped at two or three points and wire leads are run from these taps.

The end tap of the speed controller is connected directly to the hot side of the 120v line. The hot line from the motor then may be connected to any one of the taps including the line voltage connection. Regardless of the tap used, the speed controller is then connected electrically in series with the motor.

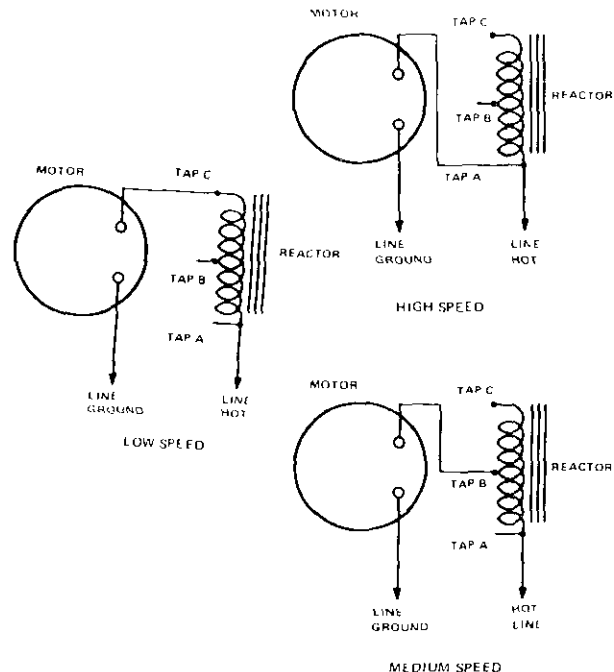

## TAP WOUND MOTORS

Another method commonly used to vary or change the motor speed is the motor tap method. A tap wound motor is provided with four or five wire leads; each is connected to a different point in the motor windings. One wire is the ground connection to the motor. The number of motor winding turns which are energized determine the motor speed. To obtain the desired speed, select a speed tap and connect it to the line. There may be either 3 or 4 speed selections. PSC motors may be tap wound.

When more windings are used, there is maximum resistance to electrical current flow, and the motor turns at low speed. As fewer windings are used, there will be less resistance to current flow, and the motor will run at a higher speed. See diagrams.

The identification of the speed taps appears in a table on the furnace wiring diagram. Using this, select two leads to obtain the desired speed.

**NOTE:** The unused leads must then be taped separately so that they will not short out.

Some of the newer model furnaces are equipped with motor quick-connect terminals in the wiring junction box. Each of the tap wound motor leads is also equipped with a quick-connect fitting. In this case the desired leads may be connected to the two line terminals. Insulated dummy terminals can also be used for the unused leads. These do not have to be taped.

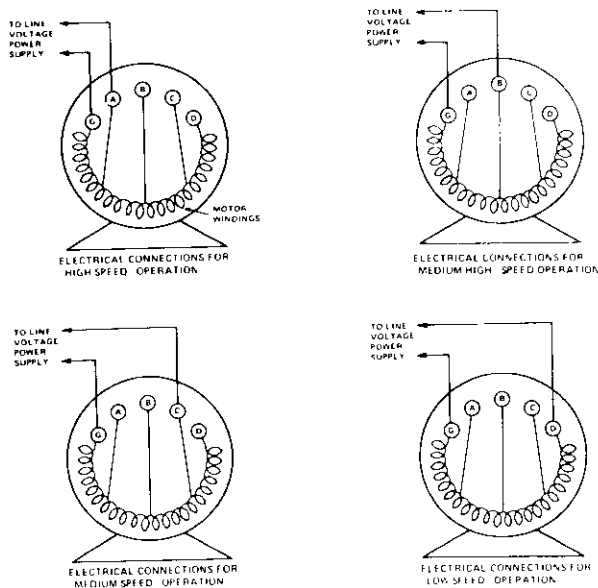

## OPERATING AMPERAGES OF MOTORS

Anticipating or at least having an idea of the operating amperage of any motor is always to the service person's advantage. This can be found on unit nameplates and motor nameplates. Here is a table indicating average running amps for various fractional and nominal horsepower motors in both 115 volt and 230 volt models.

HP	AVERAGE RUNNING AMPS	
	Single Phase 115v	230v
1/6	4.4	2.2
1/4	5.8	2.9
1/3	7.2	3.6
1/2	9.8	4.9
3/4	13.8	6.9
1	16	8
1-1/2	20	10
2	24	12
3	34	17
5	56	28
7-1/2	80	40
10	100	50

## SERVICE CHECKS FOR INDUCTIVE LOADS

The service checks for inductive loads that allow the service person to determine the electrical condition of a load are the same as those for resistive loads. Since the inductive load's check is again an ohm's check, the power must be off, the load electrically isolated, and the ohmmeter must be zeroed. Following is a summary of these checks.

## CAPACITIVE LOADS

Capacitors are electrical storage devices often used in conjunction with the starting and/or running circuits of induction motors. The capacitor is important because it can affect the operating wattage, amperage draw, torque, speed, efficiency, and power factor of a motor.

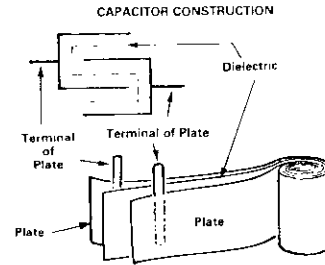

The construction of a capacitor consists of two separate metal plates separated by an insulator, commonly called a dielectric. The circuits of the middle plates are used to collect electrons. Therefore, the surface area of the metal plates will influence the number of electrons stored. Capacitors are rated according to their storage capabilities. The unit of measure is the farad. Capacitors are rated in millionths of farads called micro-farads. The greater the micro-farad rating, the greater the ability of the capacitors to store electrons. Capacitors also have a voltage rating. This is an indication of the insulating capability of the dielectric. The greater the voltage rating, the thicker the dielectric. The thickness of the dielectric determines the placement of the plates. The thicker the dielectric, the farther the plates are apart.

Capacitors are usually named by the type of dielectric used. There are paper capacitors, plastic capacitors and ceramic capacitors. A common type of capacitor is the electrolytic. The electrolytic capacitor is designed for intermittent duties—rated at 20, 3 second starts per hour at 120 degrees maximum operating temperature. It is designed for 50,000 starts. If it fails, the electrolytic capacitor will fail open about 85% of the time. The plates of an electrolytic capacitor are rolled in an acid or salt medium. They are usually sealed in a plastic container.

Another type of capacitor is the oil-filled, continuous duty capacitor. If operated within specifications, it is designed to give 12 to 15 years of operation. A 10% increase in continuous supplied voltage or a 10 degree rise in capacitor case temperature will reduce the life expectancy of the capacitor by 25%. If the continuous duty (run) capacitor fails, it will normally fail open. It may show a bulge. The oil used in this style of capacitor serves to dissipate heat. In the past, this oil contained polychlorinated biphenyls. Because of environmental hazards, capacitor manufacturers have now gone to non-PCB polychlorinated biphenyl (capacitors).

The run capacitor's job is to dampen the minor voltage variations in the line and supply constant voltage to the compressor motor. It, therefore, improves motor efficiency and increases the power factor, allowing maximum use and economy from the current supplied by the power company.

Sometimes on a service call, due to availability, it is necessary to wire two capacitors together to obtain a specific micro-farad ratings. When capacitors are wired in parallel, the equivalent micro-farad rating is the sum of the individual capacitor micro-farad ratings. The capacitance of each capacitor is added together for total capacitance. The equivalent voltage rating is the lowest voltage rating of the capacitors wired. This means that wiring capacitors in parallel has the effect of increasing plate area. Although the surface area of the plates is increased, the dielectric distance remains the same.

When capacitors are wired in series, the micro-farad drops. A formula can be used to calculate the equivalent micro-farad rating of capacitors wired in series. The capacitance of two capacitors wired in series will be one-half the capacitance of a single capacitor. The voltage rating equivalent is simply the sum of the individual voltage ratings of the capacitors wired. Wiring capacitors in series has the effect of increasing the thickness of the dielectric while leaving the plate area the same.

Remember, THE VOLTAGE RATINGS ON ANY CAPACITOR ARE ITS ACTUAL OPERATING VOLTAGE AND NOT A SAFETY FACTOR. Therefore, never substitute a capacitor with a lower voltage rating. It is possible to substitute capacitors with a higher voltage rating. If in doubt about the voltage rating on the equipment, always use 440v capacitor for 230v applications. Capacitance rating is also critical to run capacitors, and only very small deviations on the plus side are used.

The pictorial diagram shows the run capacitors wired into the circuit. Note that 2 run capacitors are wired across the start and run windings of the motor.

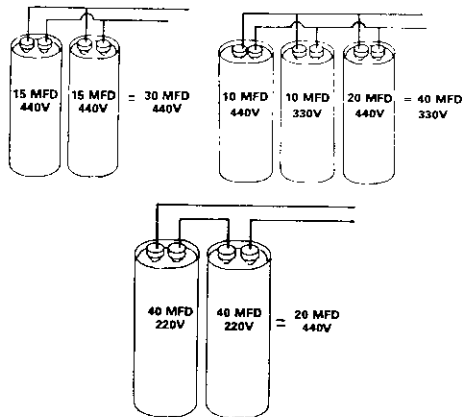

$$\frac{1}{C_T} = \frac{1}{C_1} + \frac{1}{C_2} + \frac{1}{C_3} \text{ etc.}$$

#### SERVICE CHECK FOR CAPACITIVE LOADS

The service check procedures for capacitors utilize a type of ohm's check. It is summarized by the following illustrations. Several capacitor analyzers are on the market. To have confidence in the electrical condition of the capacitor, use one of these devices when checking capacitive loads.

#### POWER FACTOR

Because inductance and capacitance have opposing effects in a circuit, capacitors are used with a motor or on a power line to improve the power factor. In an alternating current circuit, containing pure resistance only, power in watts is equal to the product of volts and amps.  $P=EL$ . This means that an incandescent lamp drawing 0.8 amps on 120 volt line would be:  $P = EL = 120 \times 0.8 = 96$  watts. This is almost a 100 watt bulb. The formula would work like this for a 120 volt circuit containing several resistant devices with the total amp draw of 15.  $P=EL=120 \times 15 = 1,800$  watts or 1.8 kilowatts. The power factor is almost 100% for this type of circuit; in other words the circuit almost uses the calculated 1,800 watts. The definition of power factor is the ratio of consumed power to supplied power or the percentage of time that the product of volts and amps equals actual power.

The voltage and current must be in phase for a 100% power factor to exist. When inductive reactance or capacitive reactance causes the current to lag or lead the voltage (meaning it is out of phase), the product of volts and amps gives only apparent power rather than actual power.

This means that a utility connected to a typical commercial circuit high in inductance must supply some power which does not actually perform work. This power is not measured on a normal watt meter and deprives the company of revenue. For example, the calculation of measured volts and amps equals 2,000 watts, but the device on the circuit line actually shows 1,600 watt consumption. Therefore, the power factor is:

$$PF = \frac{1,600}{2,000} \times 100 = 80\%$$

Only 80% of the supplied power is doing measurable work. The remaining 20% is magnetizing current. This 20% enables induction devices to function, but it does no work itself; therefore, this 20% is not normally recorded.

Induction devices such as motors and florescent lighting uses so much magnetizing current, utility companies dislike this type of illumination. However, because induction devices are necessary to our technology, power companies have established a practical minimum power factor of 90% which must be maintained on their lines.

Due to design and application, motors may have an inherent power factor as low as 60%. Based on wave forms, the inductive reactance is causing the current to lag considerably behind the voltage. Capacitive reactance tends to make the current lead the voltage; therefore, if capacitance is placed in the line, a low power factor due to inductance can be raised.

Capacitance is raised in the line when a running capacitor is placed on a motor; when a bank of capacitors is installed in an industrial plant; when utility companies strategically locate pole capacitors on distribution lines. The resulting capacitance acts in opposition to the inductance, thereby establishing a more favorable power factor than would be possible with only inductance acting on the line.

#### JOINING TECHNIQUES FOR COPPER AND ALUMINUM CONDUCTORS

Because aluminum and copper have dissimilar electrical and chemical properties, electrically joining copper and aluminum conductors can present some service problems. In order to prevent these problems, use the following joining techniques.

To prevent electrical problems, closely adhere to the following items on equipment installations:

1. Use only connectors which are Underwriters' Laboratories approved for aluminum-copper usage. Such connectors will be tin plated; have separate bars for placement between conductors to prevent direct contact between aluminum and copper; and have proper bearing surfaces to minimize unit pressures for minimum cold flowing of the aluminum wire and subsequent loosening of joints.
2. After insulation is stripped from aluminum conductor, coat the end of this conductor with corrosion inhibitor, such as Burndy "Penetrox A." Then wire brush through the inhibitor to the aluminum surface.
3. After cleaning, recoat aluminum conductor with Penetrox A and make connections.

IMPORTANT - Follow the manufacturer's recommendations of torque requirements for tightening all connections.

4. After connections are tight, coat the entire connection with Penetrox A.
5. If possible, provide suitable wrap around the connection for moisture and/or electrical protection.

CAUTION - It is recommended that terminal connections to a contactor be made with copper. When aluminum wire is used, we recommend that: (1) short lengths of properly sized copper wire be connected to the contactor and then properly spliced to the aluminum power supply wiring with suitable connectors, or (2) copper wiring be used from the unit contactor and then joined to the aluminum field wiring at a field installed disconnect switch that is suitable for both copper and aluminum conductors.

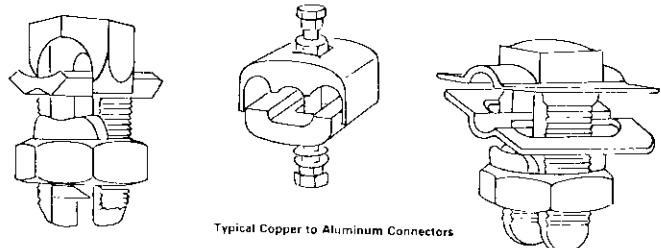

Typical Copper to Aluminum Connectors

60°C COPPER WIRE SIZE (FOR 3% VOLTAGE DROP)

SUPPLY WIRE LENGTH-FEET	SUPPLY CIRCUIT AMPACITY									
	15	20	30	40	55	70	85	95	110	125
100	14	12	10	8	6	4	3	2	1	0
150	12	10	8	8	6	4	2	1	0	00
200	12	10	8	6	4	3	2	0	0	00
250	10	8	6	6	4	3	2	0	00	000
300	8	8	6	6	4	3	2	0	00	000

60°C ALUMINUM WIRE SIZE (FOR 3% VOLTAGE DROP)

SUPPLY WIRE LENGTH-FEET	SUPPLY CIRCUIT AMPACITY										
	15	25	30	40	55	65	75	85	100	115	130
100	12	10	8	6	4	3	2	1	0	00	000
150	10	8	6	6	4	3	2	1	0	00	000
200	8	6	4	4	3	2	1	0	00	000	0000
250	8	4	4	3	2	2	1	0	00	000	0000
300	6	4	3	3	2	1	0	00	000	0000	0000

75°C COPPER WIRE SIZE (FOR 3% VOLTAGE DROP)

SUPPLY WIRE LENGTH-FEET	SUPPLY CIRCUIT AMPACITY								
	15	20	30	50	65	85	100	115	130
100	14	12	10	8	6	4	3	2	1
150	12	10	8	6	6	3	2	1	0
200	12	10	8	6	4	3	2	1	0
250	10	8	6	4	4	2	1	0	0
300	8	8	6	4	3	2	1	0	00

75°C ALUMINUM WIRE SIZE (FOR 3% VOLTAGE DROP)

SUPPLY WIRE LENGTH-FEET	SUPPLY CIRCUIT AMPACITY									
	15	25	40	50	65	75	90	100	120	135
100	12	10	8	6	4	3	2	1	0	00
150	10	8	6	4	3	3	2	1	0	00
200	8	6	4	4	3	2	1	0	00	000
250	8	4	4	3	2	1	0	0	00	000
300	6	4	3	2	1	1	0	00	000	0000

NOTE: ALL OF ABOVE TABLES ARE BASED ON NOT MORE THAN THREE (3) CONDUCTORS IN RACEWAY OR CONDUIT. IF 4 THROUGH 6 CONDUCTORS ARE USED IN A COMMON RACEWAY OR CONDUIT, THE AVAILABLE AMPACITY OF ALL CONDUCTORS IS REDUCED BY 20% (MULTIPLY ALL VALUES BY .80 TO OBTAIN DERATED VALUE.

ALL WIRES, BOTH SUPPLY AND GROUND COUNT TOWARDS THE TOTAL NUMBER OF CONDUCTORS.

# symbols

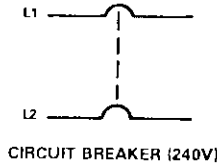
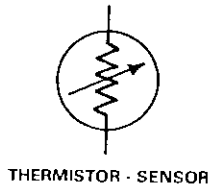
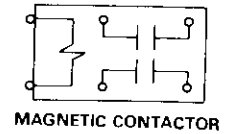
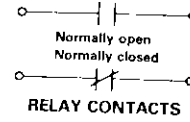
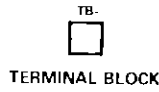
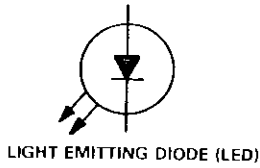
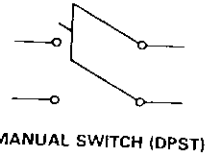
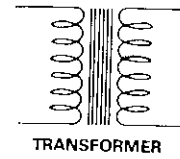
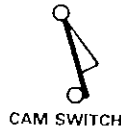

## TEMPERATURE-ACTUATED SWITCHES

