

# INSTALLATION INSTRUCTIONS

## MODELS

HI-BOY  
COUNTERFLOW

## GAS FURNACES

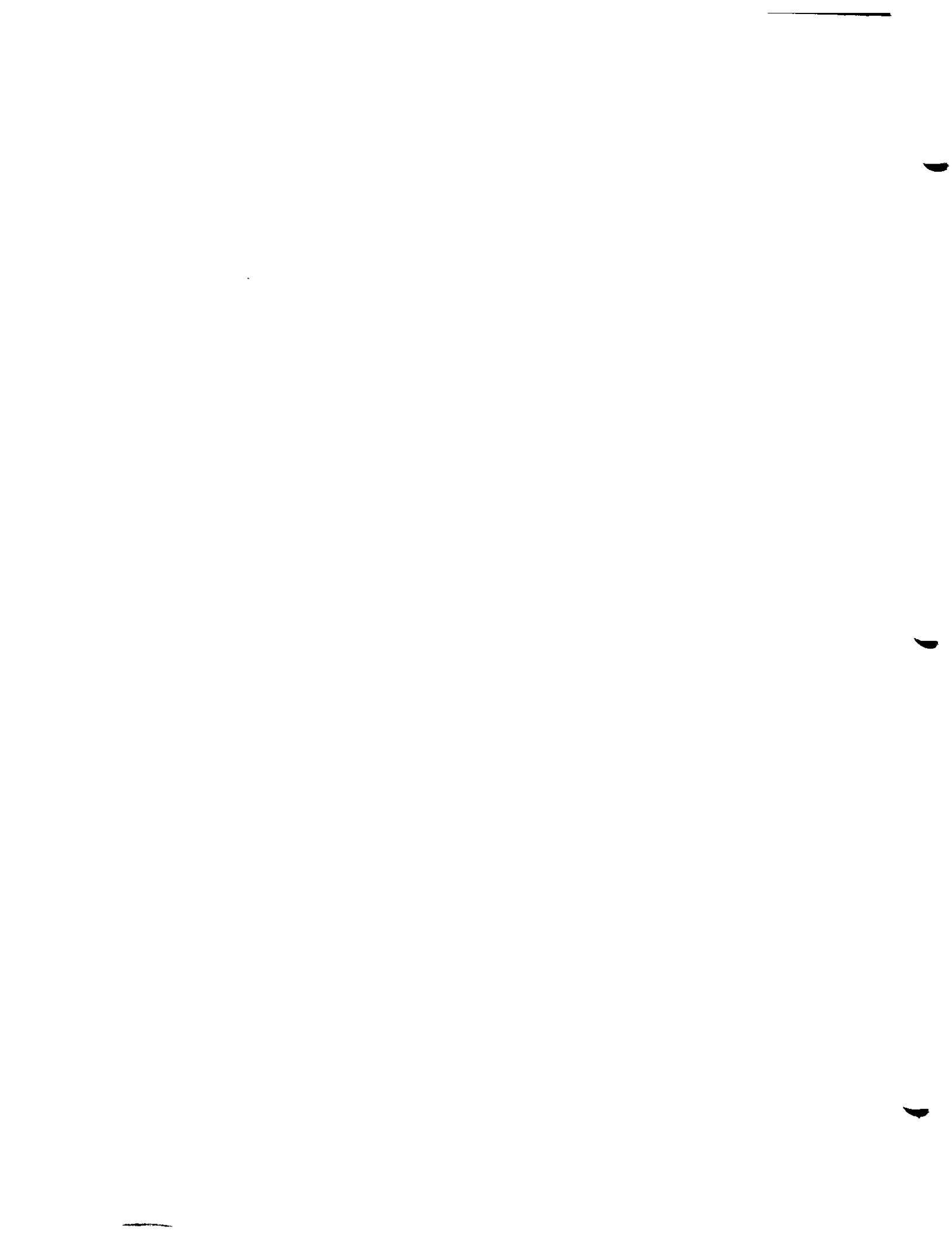

**APPLICATION**

This is a forced air gas furnace for indoor installation in building constructed on site. The furnace installation must conform with local building codes and ordinances or, in their absence with the National Fuel Gas Code, ANSI Z223.1-1984, and the National Electrical Code, ANSI/NFPA 70-1984. It is the personal responsibility and obligation of the purchaser to contract a qualified installer to assure that installation is adequate and is in conformance with governing codes and ordinances.

**HIGH ALTITUDE APPLICATIONS**

Rating of gas utilization equipment are based on sea level operation and need not be changed for operation at elevations up to 2,000 feet. For operation at elevations above 2,000 feet and, in the absence of specific recommendations from the local authority having jurisdiction, equipment ratings shall be reduced at the rate of 4 percent for each 1,000 feet above sea level before selecting appropriately sized equipment. (Ref. ANSI Z223.1-1984, Par. 8.12).

**TRANSPORTATION DAMAGE**

All units are packed securely in shipping container. All units should be carefully inspected upon arrival for damage. In the event of damage, the consignee should:

1. Note on delivery receipt of any damage to container.
2. Notify carrier promptly, and request an inspection.
3. In case of concealed damage, the carrier must be notified as soon as possible within 15 days after delivery.
4. Claims for any damage, apparent or concealed, should be filed with the carrier, using the following supporting documents, and within the 9-month statute of limitations.
  - a) Original Bill of Lading, certified copy, or indemnity bond.
  - b) Original paid freight bill or indemnity in lieu thereof.
  - c) Original invoice or certified copy thereof showing trade and other discounts or deductions.
  - d) Copy of the inspection report issued by carrier's representative at the time damage is reported to carrier.

The carrier is responsible for making prompt inspection of damage and for a thorough investigation of each claim.

**LOCATING THE FURNACE**

When selecting a location for the furnace, observe the following points:

1. The furnace should be set on a level floor. If the floor may become damp or wet at times, the furnace should be supported above the floor using a concrete base, bricks, patio blocks, etc., making sure adequate support is available for the furnace. Counterflow furnaces require use of combustible floor base if installed on combustible surface. The combustible floor base is not part of the furnace and must be ordered separately. Furnaces approved for installation on combustible flooring shall not be installed directly on carpeting, tile or other combustible material other than wood flooring.
2. The furnace should be as centralized as practical with respect to the air distribution system.
3. Provisions must be made for venting combustion products outdoors through an individual venting system.
4. Provide at least the minimum clearances specified in Fig. 1 for fire protection, proper operation and service access. These clearances must be permanently maintained. The combustion and ventilating air openings in the front of the furnace must never be obstructed.
5. Minimum service clearances must take precedence over fire protection clearances (minimum installation clearances).
6. All models are approved for a utility room or closet installation.
7. A gas-fired furnace installed in a residential garage must be installed so that the burners and ignition source are located not less than 18 inches above the floor, and the furnace must be located or protected to avoid physical damage by vehicles.

**FIGURE 1. MINIMUM CLEARANCES**

MODEL	MINIMUM INSTALLATION CLEARANCES ①						MINIMUM ① SERVICE CLEARANCES
	Top	Front	Flue	Back	Sides	Floor	Front
60,000 - 80,000 Hi-Boy	1	6	② 6 ④	0	③ 1 ④	C	24
105,000 - 120,000 140,000 - 160,000 Hi-Boy	1	6	6	0	0	C	24
200,000 Hi-Boy	1	6	6	1	1	C	24
60,000 - 80,000 Counterflow	1	6	② 6 ④	0	③ 1 ④	NC	24
105,000 - 120,000 140,000 - 160,000 Counterflow	1	6	6	0	0	NC	24

① All clearances are in inches.      ④ On these models, reduced clearances per notes ② and ③ do not apply if vent damper is used.      ⑤ 0" if note ③ applies.  
 ② 1" if Type B-1 vent is used.  
 ③ 0" if Type B-1 vent is used.  
 C - Floor may be combustible material.  
 NC - Floor must be non-combustible.

## DUCT WORK

The air distribution system should be designed and installed in conformance with Manuals 7 or 7A published by Air Conditioning Contractors of America (ACCA), as set forth in their Manual K.

### CAUTION

When a furnace is installed so that supply ducts carry air circulated by the furnace to areas outside the space containing the furnace, the return air must also be handled by a duct(s) sealed to the furnace casing and terminating outside the space containing the furnace. This is to prevent drawing possible hazardous combustion products into the circulated air.

When the furnace is used in connection with a cooling unit\*, the furnace shall be installed parallel with or on the upstream side of the cooling unit to avoid condensation in the heating element. With a parallel flow arrangement, the dampers or other means used to control flow of air shall be adequate to prevent chilled air from entering the furnace and, if manually operated, must be equipped with means to prevent operation of either unit, unless the damper is in the full heat or cool position.

\*A cooling unit is an air conditioning coil, heat pump coil or chilled water coil.

## COMBUSTION AND VENTILATION AIR

The furnace and furnace room must have an adequate supply of air for safe combustion and ventilation. The provisions necessary to assure an adequate air supply will vary depending upon differences in the tightness of house construction and in the location of the furnace. Methods of providing air from some typical situations are described below. Consult local codes and ordinances for requirements applicable to your specific furnace installation conditions and comply with them. In the absence of local codes and ordinances, comply with the National Fuel Gas Code, ANSI Z223.1-1984.

### EXAMPLE 1 -- FURNACE LOCATED IN AN UNCONFINED SPACE

A. If the furnace is located in a basement or other large, open area of a conventionally built house (loose construction), the air that leaks into the building normally will provide an adequate air supply.

### EXAMPLE 2 -- FURNACE LOCATED IN A CONFINED SPACE

- A. When the furnace is in a closet or utility room, install two open grilles in a wall or door opening to the rest of the house. Each grille must have a free area of at least one square inch for each 1000 Btuh of total input rating of all gas appliances in the confined space. Refer to Figure 2. The grilles must communicate with other open areas having adequate air infiltration from outdoors.
- B. If the building is tightly constructed, not enough outside air may enter for safe combustion. Install a fresh air duct from a point near the burners to the outside or to a ventilated attic or crawl space. Refer to Figure 3. This duct must have a free area of at least one square inch for each 4000 Btuh of total input of all gas appliances in the space. The minimum dimension of a rectangular duct must not be less than three inches.

### CAUTION

When a furnace is installed in a closet or utility room, never use this room as a return air plenum.

FIGURE 2 — FURNACE LOCATED IN CONFINED SPACE

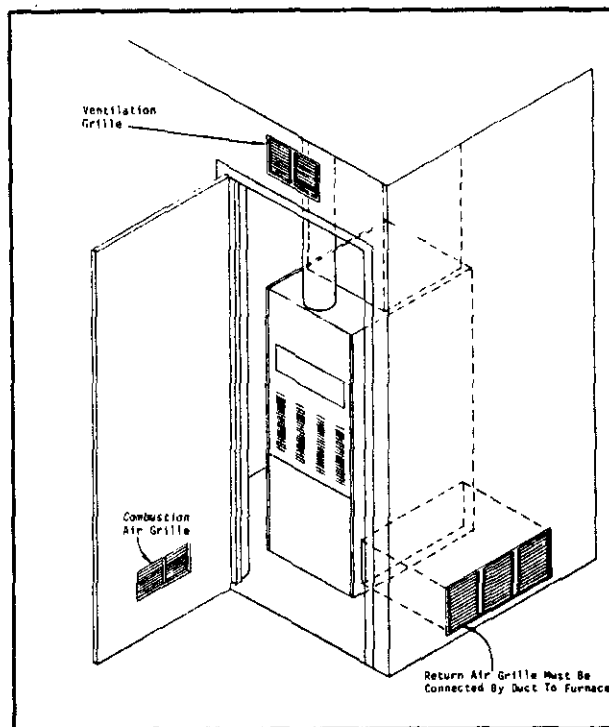

FIGURE 3 — FRESH AIR DUCT FOR TIGHTLY SEALED BUILDING

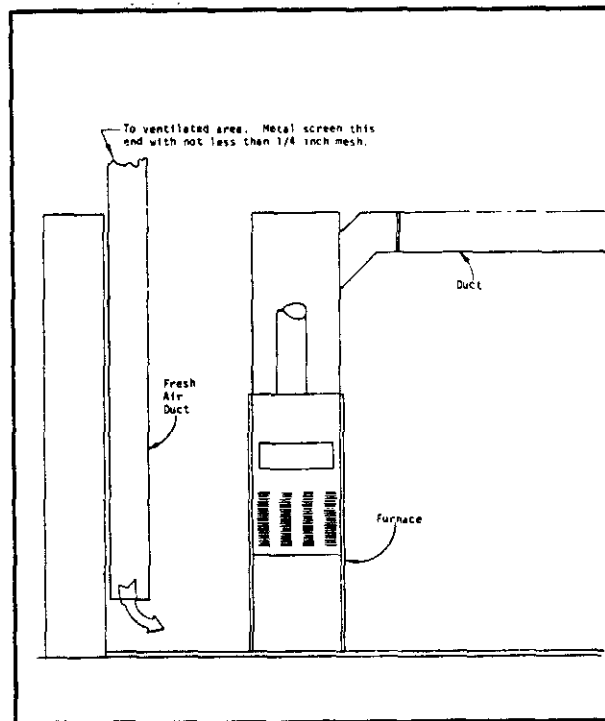

FIGURE 4 -- CHIMNEY OR VENT CAP INSTALLATION

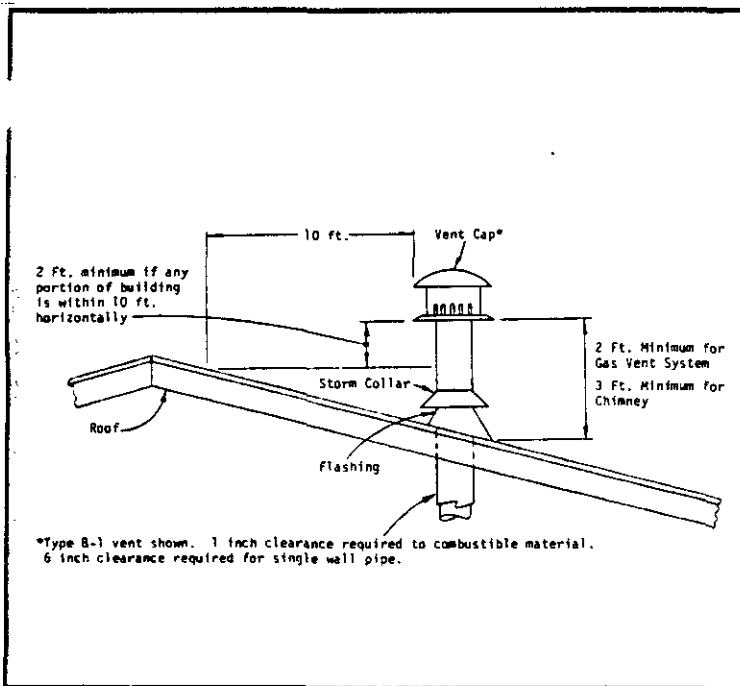

FIGURE 6 -- VENT THROUGH FLOOR

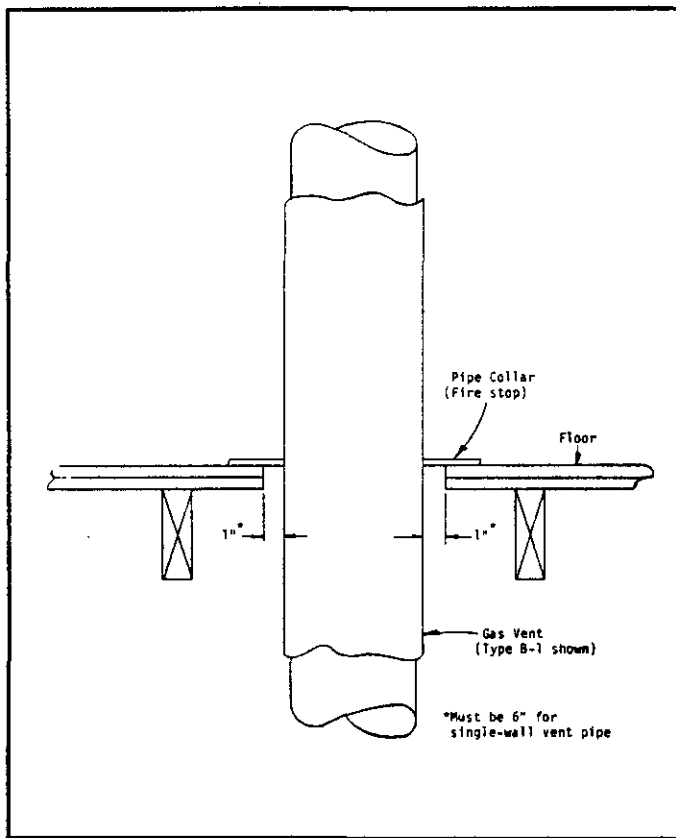

FIGURE 5 -- HORIZONTAL VENTING, COMBUSTIBLE WALL

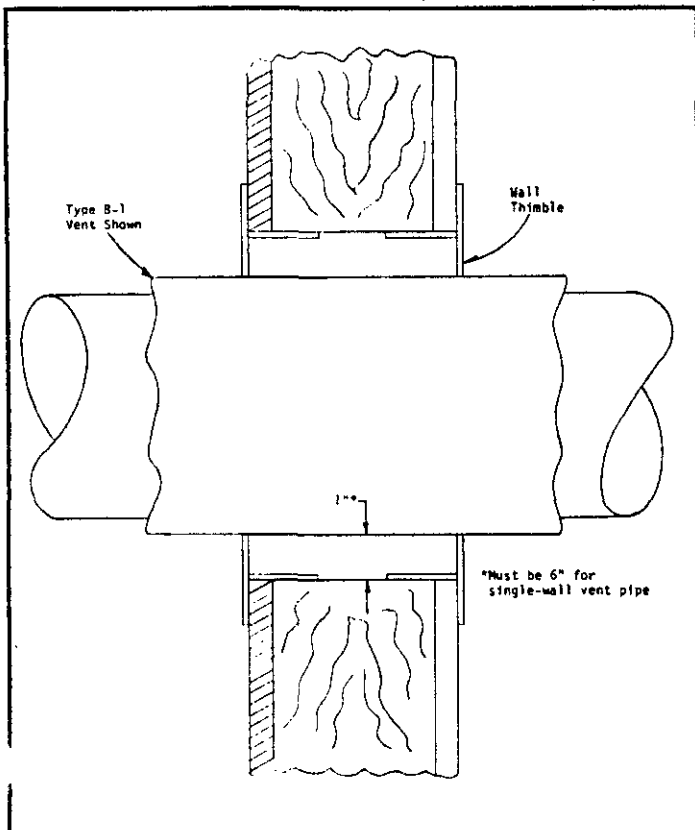
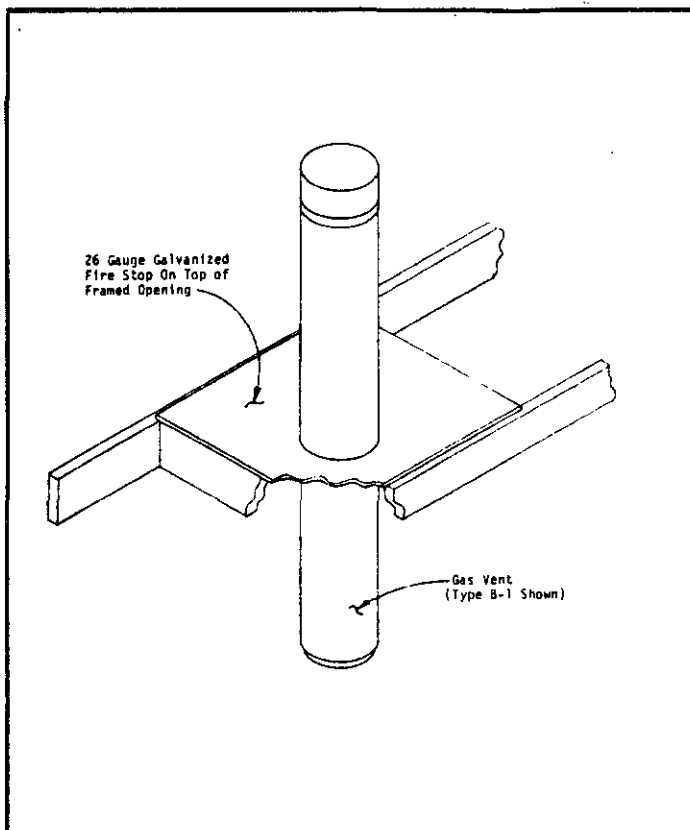

FIGURE 7 -- VENT THROUGH CEILING



### VENT PIPE CONNECTION

This furnace must be vented either directly to the outside or connected into a suitable masonry chimney. The vent installation shall be in accordance with Part 7, Venting of Equipment, of the National Fuel Gas Code, ANSI Z223.1-1984, or applicable provisions of the local building codes.

### GENERAL INSTRUCTIONS

1. The vent pipe must be the same size as the outlet of the draft diverter hood.
2. A furnace shall not be connected to a chimney flue serving a separate appliance designed to burn solid fuel.
3. Vent connectors serving appliances vented by natural draft shall not be connected into any portion of mechanical draft systems operating under positive pressure.
4. Maintain a minimum clearance of 6 inches (1 inch for Type B-1) between the vent pipe and any adjacent combustible materials. This rule applies whether the vent is enclosed or installed in the open; is horizontal or vertical, or passes through floors, walls, roofs, or furred out spaces. Joists, studs, floors, dry wall, sheathing, rafters, roofing and other materials classified as combustible must not be closer than 6 inches (1 inch for Type B-1) to the flue.
5. Where two appliances vent into a common flue, the area of the common flue should equal the sum of the areas of the individual vent pipes.
6. If connected into a chimney, the vent pipe must be inserted into, but not beyond the inside wall of the chimney.
7. The gas vent must extend at least 2 feet above the highest point where it passes through the roof of a building (3 feet for a chimney) and at least 2 feet higher than any portion of a building within a horizontal distance of 10 feet. See Figure 4.
8. The vent pipe system shall be installed so as to avoid excessive turns which create unnecessary resistance to flow of vent gases.
9. Horizontal runs shall be as short and direct as possible. The maximum length of a single-wall vent pipe shall not exceed 75 percent of the height of the vent system. The maximum length of a Type B-1 double wall vent connection shall not exceed 100 percent of the height of the vent system.
10. All horizontal vent pipe shall be pitched upward from the furnace at least 1/4 inch per foot.
11. Horizontal portions of the vent system shall be supported to prevent sagging. Pipe strap or equivalent means should be used every 3 to 5 feet depending upon pipe joint lengths.
12. All vent systems shall be adequately supported to maintain proper clearances, to prevent physical damage, and to prevent separation of the joints.
13. Vents passing through a combustible wall or partition must use a ventilated wall thimble. See Figure 5.
14. Vents passing through floors or ceilings must be fire-stopped. See Figure 6 and Figure 7.

### LENGTH OF STANDARD PIPE THREADS (inches)

PIPE SIZE	EFFECTIVE LENGTH OF THREAD	OVERALL LENGTH OF THREAD
3/8	3/8	9/16
1/2	1/2	3/4
3/4	1/2-9/16	13/16
1	9/16	1

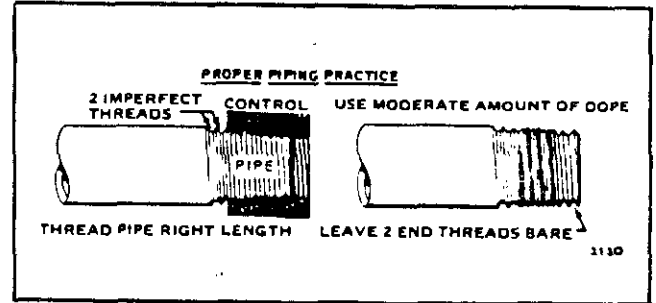
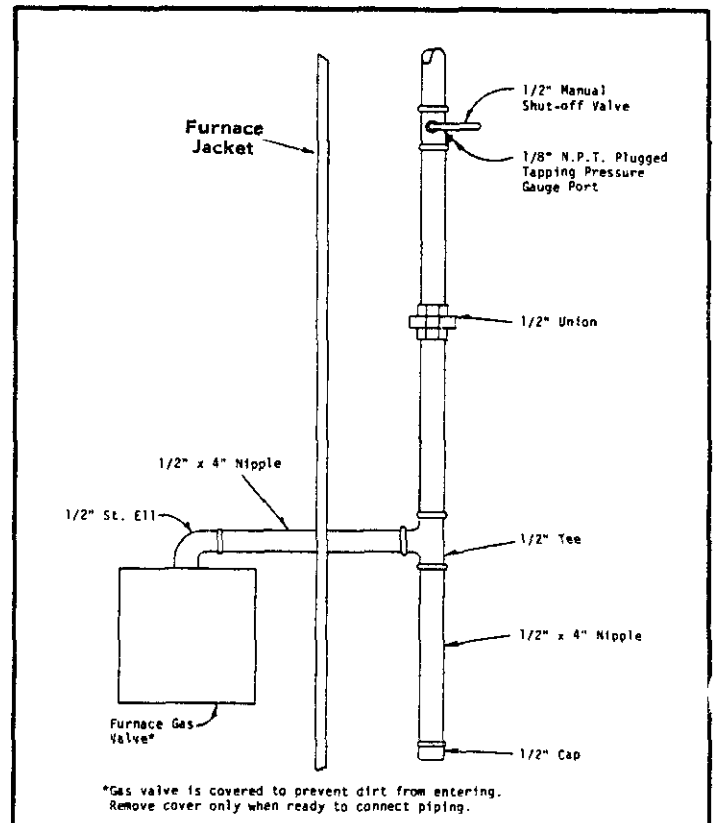

FIGURE 8 - GAS PIPE SIZES -- NATURAL GAS

Length of Pipe, Ft.	Pipe Capacity -- Btu Per Hour Input Pipe Size			
	1/2"	3/4"	1"	1-1/4"
10	132,000	278,000	520,000	1,050,000
20	92,000	190,000	350,000	730,000
30	73,000	152,000	285,000	590,000
40	63,000	130,000	245,000	500,000
50	56,000	115,000	215,000	440,000
60	50,000	105,000	195,000	400,000
70	46,000	96,000	180,000	370,000
80	43,000	90,000	170,000	350,000
100	38,000	79,000	150,000	305,000

FIGURE 9 - TYPICAL GAS PIPING



\*Gas valve is covered to prevent dirt from entering. Remove cover only when ready to connect piping.

## GAS SUPPLY AND PIPING

### General Recommendations

1. Be sure the gas line complies with the local codes and ordinances, or in their absence with National Fuel Gas Code, ANSI Z223.1-1984.
2. A sediment trap or drip leg must be installed in the supply line to the furnace.
3. A ground joint union shall be installed in the gas line adjacent to and upstream from the gas valve and downstream from the manual main shut off valve.
4. A 1/8" N.P.T. plugged tapping accessible for test gauge connection shall be installed immediately upstream of the gas supply connection to the furnace for the purpose of determining the supply gas pressure.
5. A manual shut-off valve shall be installed in the supply gas line external to the furnace when required by local code. See Figure 9.
6. Use steel or wrought iron pipe and fittings.
7. DO NOT thread pipe too far. Valve distortion or malfunction may result from excess pipe within the control. Use pipe joint compound resistant to the action of liquified petroleum gases on male threads only. DO NOT use Teflon tape. See illustrations.
8. Refer to Figure 8 for Gas Pipe Sizes for natural gas. If more than one appliance is supplied from a single line size, capacity must equal or exceed the combined input to all appliances, and the branch lines feeding the individual appliances properly sized for each input.

### CHECKING THE GAS PIPING

Before turning gas under pressure into piping, all openings from which gas can escape should be closed. Immediately after turning on gas, the system should be checked for leaks. This can be done by watching the 1/2 cubic foot test dial and allowing 5 minutes to show any movement, and by soaping each pipe connection and watching for bubbles. If a leak is found, make the necessary repairs immediately and repeat the above test. The furnace must be isolated from the gas supply piping system by closing the manual shutoff valve on the combination gas control valve during pressure testing of the gas supply piping system at pressures up to 1/2 psig. The furnace must be disconnected from supply piping and supply piping capped during any pressure testing of supply piping system at test pressures in excess of 1/2 psig.

Defective pipes or fittings should be replaced and not repaired. Never use a flame or fire in any form to locate gas leaks, use a soap solution.

After the piping and meter have been checked completely, purge the system of air. DO NOT bleed the air inside the furnace. Be sure to relight all the gas pilots on other appliances that may have been extinguished because of interrupted gas supply.

### WIRING

#### CAUTION

For your personal safety, turn off electric power at service entrance panel before making any electrical connections.

All electrical work must conform with local codes and ordinances or, in their absence, with the National Electrical Code, ANSI/NFPA 70-1984.

### ELECTRICAL POWER SUPPLY

Run a separate 120 volt, 15 ampere, 60 Hz, AC circuit from a separate fuse or circuit breaker in the service entrance panel. Locate a shut off switch at the furnace. Make connections from this switch to furnace junction box as shown in the furnace wiring diagram.

## ELECTRICAL GROUNDING

### A. RECOMMENDED GROUNDING METHOD

When installed, the furnace must be electrically grounded in accordance with local codes or in the absence of local codes, with the National Electrical Code, ANSI/NFPA No. 70-1984. Use a #14 AWG copper wire from green screw or green ground wire on the furnace to a grounded connection in the service panel or a properly driven and electrically grounded ground rod.

### B. ALTERNATE GROUNDING METHOD

If the recommended grounding method is impossible, permanently ground the furnace from the ground connector to a grounded cold water pipe\* using a separate, green colored, insulated conductor of appropriate size. THIS, HOWEVER, IS NOT RECOMMENDED.

\*Cold water pipe must have metal continuity to electrical ground and not be interrupted by plastic, rubber or other electrically insulating connectors (including water meter or pump) without adding a jumper wire at these connections.

NOTE: DO NOT ground to a gas supply pipe. DO NOT connect to electric power supply until appliance is permanently grounded.

### THERMOSTAT

Install the thermostat in accordance with instructions packed with it. Locate the thermostat 4-1/3 feet from the floor on an inside wall away from drafts, warm air registers and floor or table lamps. Refer to furnace wiring diagrams for connections.

All 24V wall thermostats have heat anticipators to compensate the thermostat for various system controls and allow the best possible cycle rates. Some anticipators are fixed and require no adjustment. However, the majority of wall thermostats have adjustable anticipators and do require adjustment to match the current rating of the gas valve. Most gas valves currently used are rated at .60 but check the rating of the valve on the furnace being installed to be sure.

Failure to adjust the anticipator lever to correspond to the actual current draw through the thermostat will cause severe short cycling if set too low and room temperature may never attain the thermostat set point, and if set too high, will cause room temperature to overshoot the set point.

NOTE: Optional damper does not change anticipator setting.

### BLOWER OPERATION

All three and four speed direct drive models are equipped with a heating-cooling blower relay, and when matched with the appropriate wall thermostat offers manual blower operation from the wall thermostat for air circulation.

Heating only models have no provisions for continuous air circulation, and blower operates only upon demand from combination fan-limit control based upon temperature in the heat exchanger compartment.

NOTE: On standing pilot models, it is recommended that the pilot flame be turned off on all air conditioning applications during the period when the air conditioner is expected to be operating the majority of the time (summer operation).

#### CAUTION

After the furnace is operating with filters installed and all cabinet panels are in place, check the temperature rise through the unit to insure it is within the range specified on the furnace rating plate. If it is not, adjust blower speed until the temperature rise is within specified range.

### FIELD INSTALLED EQUIPMENT

Wiring to be done in the field between the furnace and devices not attached to the furnace, or between separate devices which are field installed and located, shall conform with the temperature limitation for Type Y wire [63°F rise (36°C)] when installed in accordance with the manufacturer's instructions. Refer to wiring diagrams, pages 14 thru 17.

**FILTERS**

All models are shipped with filters. See Figure 10 for sizes. Hi-Boy models have the filters in their intended positions. Hi-Boy models are shipped with filter on the left side. They can alternately be located on right side or bottom. See following information. The counterflow models require a bracket installation and final filter location projects into return air plenum attachment to furnace. See Figure 11 and Figure 12.

**FIGURE 10**

FILTER SIZES FOR GAS FURNACES			
Model		Size	
60,000	Hi-Boy	(1)	16x25x1 P
80,000			
105,000			
120,000			
140,000			
160,000			
200,000	Hi-Boy	(2)	16x25x1 P
60,000	Counterflow	(1)	15x20 P
80,000			
105,000	Counterflow	(2)	10x20 P
120,000			
140,000	Counterflow	(1)	15x20 P
160,000			

P = Permanent Filter

**FILTER LOCATIONS--REMOVAL AND REPLACEMENT PROCEDURES - ALL HI-BOY FURNACES**

To remove filters from ALL sectional Hi-Boys, first remove the upper burner door and then the lower blower compartment door by grasping top of door and pull up and away from the furnace. Then, remove the "S" clip and spring by pulling the clip towards the front of the furnace.

For right hand side filter location, relocate filter and retaining spring assembly to right side filter brackets.

For right hand side filter location on 60,000 and 80,000 model furnaces, the optional filter rack is required because there is no room between the blower motor and right side of furnace to remove or install filter.

The filter may now be removed simply by pulling it towards the center of the furnace and outward.

The location may vary, depending on which side the installer located the return air duct.

This filter is the permanent high velocity type foam filter which may be washed and used over and over. DO NOT replace it with a fiberglass filter of the same size.

To replace filter, reverse the above process.

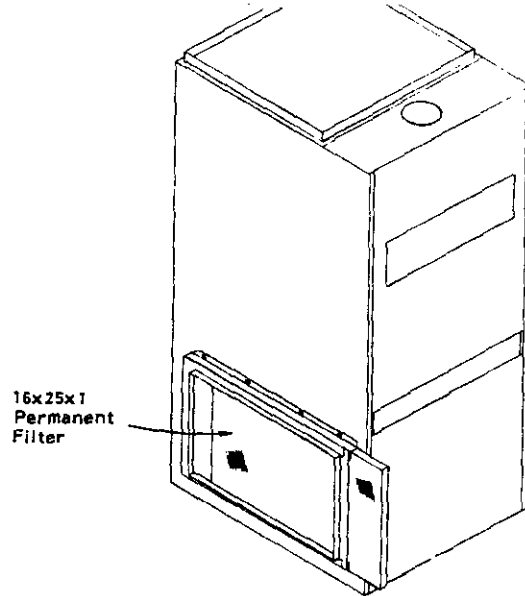

To remove filter from the optional external filter rack, grasp the exposed end of the filter and pull from the filter rack.

The location may vary, depending on which side the installer located the return air duct.

This filter is the permanent high velocity type foam filter which may be washed and used over and over. DO NOT replace it with a fiberglass filter of the same size.

To replace filter, reverse the above process.

**ALTERNATE BOTTOM FILTER LOCATION**

All Hi-Boy models except 200,000 have a removeable panel on base for a bottom return air installation.

To utilize this feature, remove the fill plate by bending the four tabs up 90°. Relocate filter retainer spring from side to bottom brackets. Leave the four tabs bent in the upright position as they will now serve to keep the filter positioned left to right.

On the 60,000-80,000 models the standard 16x25x1 filter must be cut down to 12x25x1. See illustration below.

Cut along top of rib with metal shears. Remove top 4 inches.

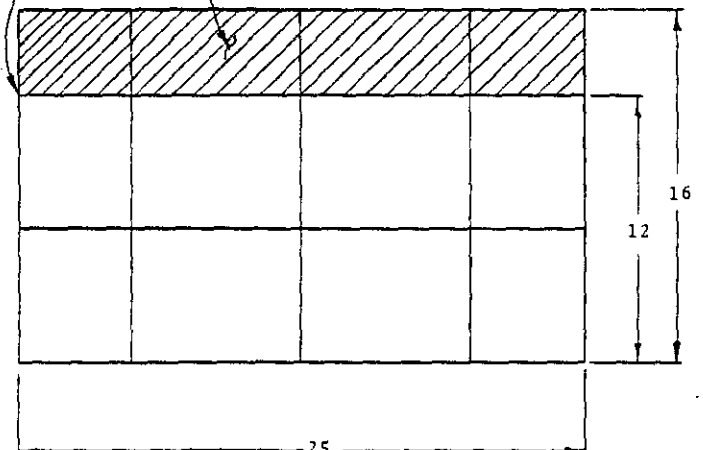
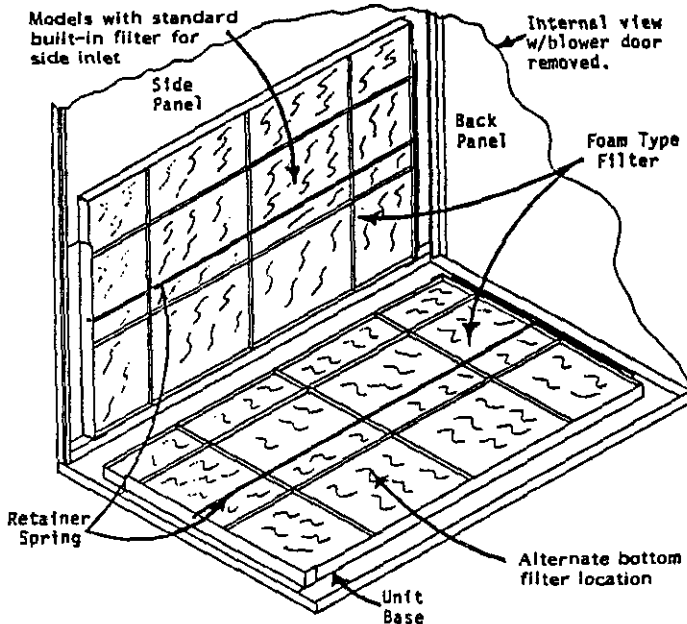



## FILTER LOCATIONS -- COUNTERFLOW MODELS

Counterflow models normally have filters installed in the return air plenum above the furnace unless a common return air/filter grille is used.

The electrical switch should be turned "off" before the front door to furnace is removed. After removing the front door, remove the left side filter door in the upper section of the furnace. Refer to the illustrations below for proper filter locations.

## REPLACEMENT PARTS

Replacement parts for the gas furnaces are available through your local distributor.

Parts lists covering all of the normally serviceable items are shown on pages 10-13. When ordering parts or making inquiries pertaining to any of the furnaces covered by these instructions, it is very important to always supply the COMPLETE model number and serial number of the furnace. This is necessary to assure that the correct parts (or an approved alternate part) are issued to the service agency.

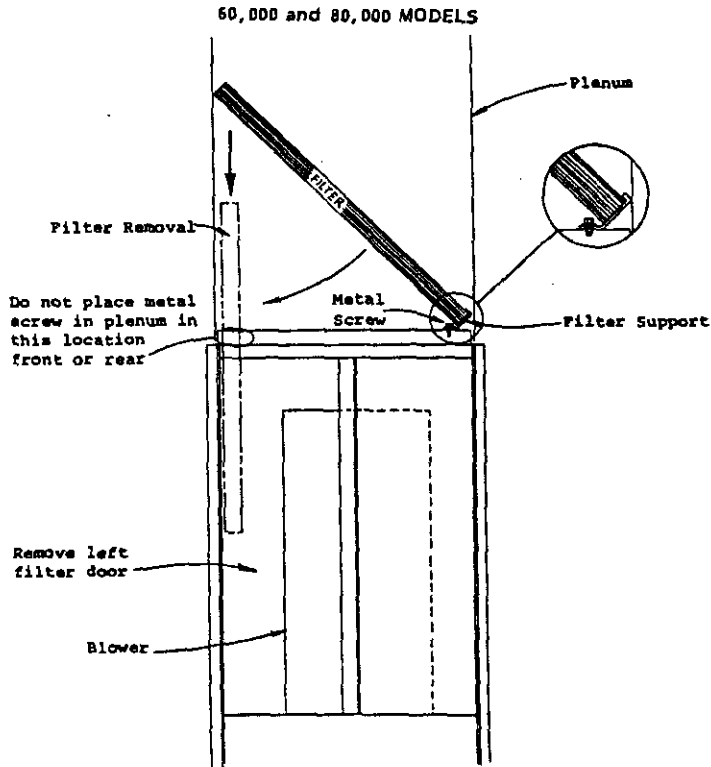

Attach filter support to furnace as shown with two sheet metal screws. The filter can be installed and removed through the left filter door.

FIGURE 11.

## PILOT BURNER LOCATIONS

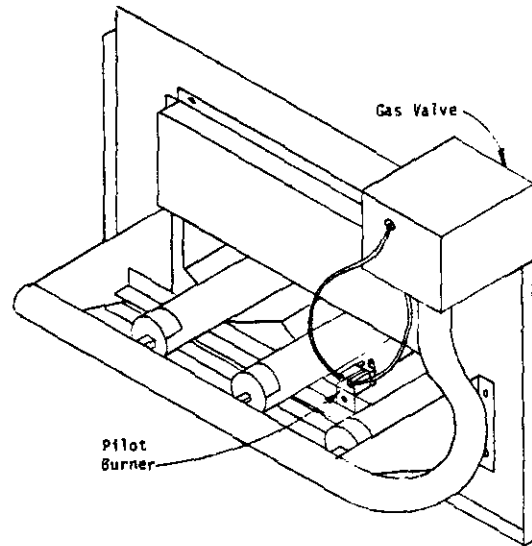

HI-BOY AND COUNTERFLOW MODELS

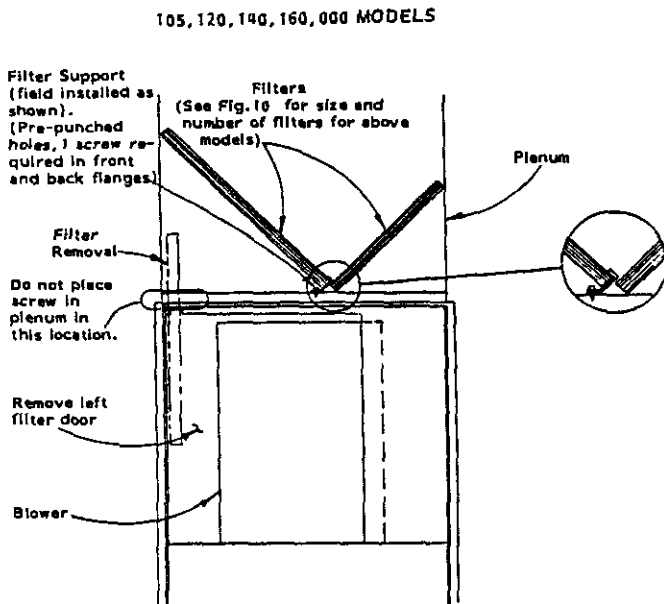

FIGURE 12.

## MAINTENANCE INSTRUCTIONS

The furnace and its vent system should be inspected annually by a qualified service agency, generally prior to the heating season.

**NOTE:** Prior to the start of any of the following maintenance procedures shut off all power to the unit.

Routine maintenance procedures are the responsibility of the owner and are contained in the Owner's Manual. These are briefly outlined below:

- Air Filters.** Check the condition on at least a monthly basis when the furnace is in use or replace whenever it is necessary.
- Lubrication Requirements.** Direct drive motors are permanently lubricated, no maintenance required. Belt drive motors and blower bearings should be oiled twice per heating season (every two months if CAC, constant air circulation, is used) with 5-6 drops of SAE20 motor oil. **DO NOT OVER OIL.**
- Fan Belt Adjustment.** Check and adjust if necessary for proper tension, approximately one inch depression with light pressure. Replace belt if cracked or frayed.
- Check Temperature Rise.** Adjust blower speed if necessary to obtain a temperature rise within the range specified on the furnace rating plate.
- Basic Examination of Furnace.** Visual inspection of pilot flame (if standing pilot model) and the main burners. Also inspection of the burner compartment and the draft diverter area for sooting and scaling.
- Periodic Inspection of the Vent System.** Visual inspection of the vent system from the furnace to the chimney for any leaking or defective parts.

## SERVICE AGENCY PROCEDURES

- If the furnace is a standing pilot model (burns all the time), observe the pilot flame. The pilot flame should be a "soft blue flame" enveloping or covering approximately 1/2 inch of the tip of the thermocouple.

FIGURE 14.

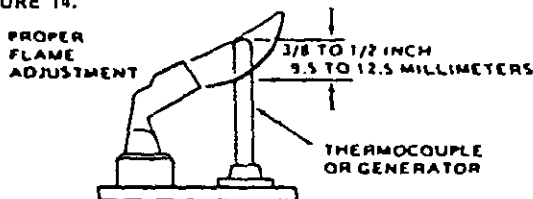

### STANDING PILOT

On intermittent pilot models, the pilot lights only when the thermostat calls for heat and the main burner lights within a few seconds thereafter. It is recommended that any observation of pilot or main burner operation be done only with the burner compartment door in place and viewing through the combustion air slots.

FIGURE 15

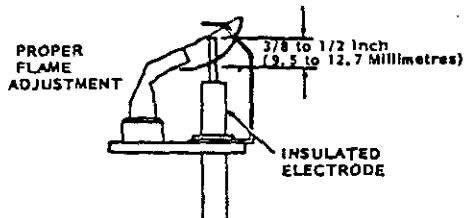

### INTERMITTENT PILOT

The pilot flame can be adjusted by removing the pilot adjustment cover screw. Turn inner adjustment screw clockwise to decrease and counterclockwise to increase pilot flame. Be sure to replace cover screw after adjustment to prevent possible gas leakage.

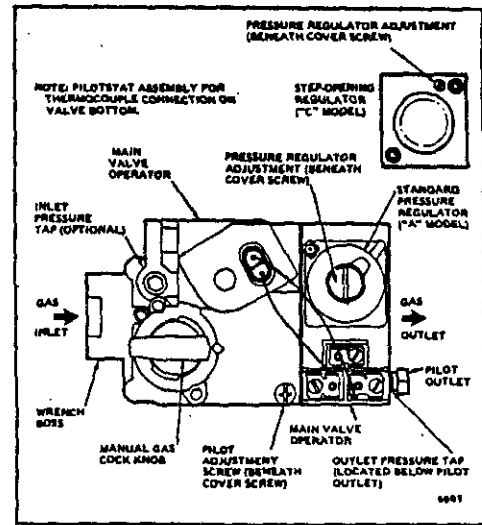

Top view of VR800 gas control - Standing Pilot

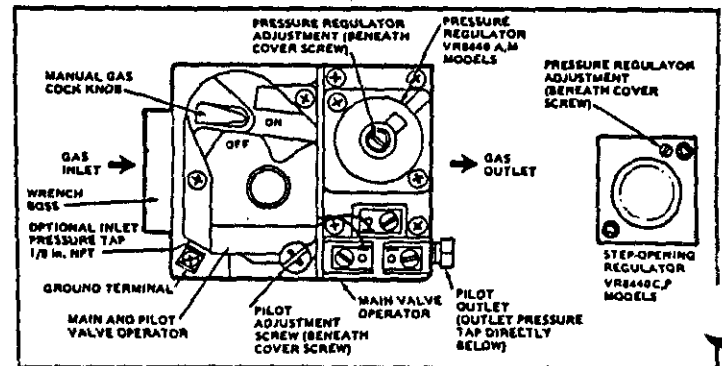

Top view of VR840 gas control - Intermittent Pilot

- Observe the main burners in operation, viewing through the combustion air slots. The flame should be mostly "blue" with possibly a little orange (not yellow) at the tips of the flames. The flames should be in the center of the heat exchanger compartments and not impinging on the heat exchanger surfaces themselves.

Observe the fire until the blower starts (there is a normal delay period until the heat exchanger warms up). There should be no change in the size or shape of the flame. If there is any wavering or blowing of the flame on the blower startup, it is an indication of a possible leak in the heat exchanger.

The air shutter on the burner(s) should be closed until "yellow" tips show in the burner flame, then opened slowly until the "yellow" tips just disappear. Then, lock the air shutter in place by means of the lock nut or set screw.

Make the final adjustment after several minutes of burner operation to assure any dust is not adding color to the flame and make it more difficult to determine yellow tipping of the burner flame.

FIGURE 16 - BURNER AIR SHUTTER ADJUSTMENT

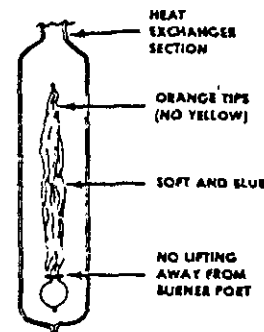

ALL MULTIPLE SECTION FURNACES

**OPTIONAL AUTOMATIC VENT DAMPER**

**IMPORTANT:** The following information is intended for use in mating the damper with current production model furnaces. These furnaces all have the redundant (dual) gas valve type and therefore do not require the optional safety switch referenced in the instructions also packed with the damper.

This unit must be installed by a qualified installer and the installer must fill out label on damper cover. This unit must be installed in compliance with local codes, or in the absence of local codes, with the National Fuel Gas Code ANSI Z223.1--1984 and the National Electrical Code ANSI C1--1981. Also, unit must be installed in a vent system so that it serves a single appliance only.

- A. Must only be used on a listed gas-fired appliance with a draft hood. The outlet area of which is no greater than the inlet area of the device.
- B. When installing the damper it must be located on the vent pipe after the draft diverter as close to the draft hood as possible without modification of draft hood. Screw securely to furnace and vent piping.
- C. Clearance of not less than 6 inches (152mm) from any combustible material is required when installing unit.
- D. Prior to installing the unit check all the venting from the appliance to the outermost area of the venting. The venting should be checked for any holes or corrosion and although the damper is of stainless steel that will last for many years, the appliance/damper combination should be checked yearly by a qualified service agency.
- E. Damper must be installed with position indicator in a visible location, and allow access to damper for inspection.
- F. The damper is to be located so as no error is made as to which appliance it serves. See Figure A and B. Damper must serve a single appliance only.

**FOR ALL ELECTRIC IGNITION SERIES FURNACES**

1. All electric ignition furnaces are built with a four pin plug designed to mate with the four pin plug on the damper wiring cord. These plugs are mounted into a bracket spotwelded to the furnace side just to the left of the draft diverter. Pull out the 4 inch red jumper wire from the mating connector on the furnace, align the plug from the damper correctly, and push together. It will only go one way and the wire colors in the furnace and on the damper will match up. The red jumper wire is shipped in place from the factory to allow the furnace to operate if the optional vent damper is NOT INSTALLED.
2. After the remainder of the venting system is installed, the installation is ready to be checked out. Turn on electric and gas to furnace and cycle damper and furnace through two or three complete cycles by turning the thermostat up and down. Damper unit takes about 7½ seconds open or close.
3. Insofar as is practical, close all building doors and windows and all doors between the space in which the appliance is located and other spaces of the building. Turn on any exhaust fans (range hood, bathroom exhausts, etc.) so they will operate at maximum speed. DO NOT operate a summer exhaust fan. Close fireplace dampers.
4. Place appliance in operation. Follow the lighting instructions. Adjust thermostat so appliance will operate continuously.
5. Test for spillage at the draft hood relief opening after 5 minutes of main burner operation. Use a match, candle or smoke from a cigarette, cigar or pipe.
6. Visually determine that main burner gas is burning properly: i.e., no floating, lifting or flashback. Adjust the primary air shutter(s) as required.
7. Determine that the pilot(s) is burning properly and that main burner ignition is satisfactory by turning the main power supply switch off and on.
8. Check both the limit control and the fan control for proper operation.

**NOTE:** The switch on the front of the damper control box is an override switch for emergency use in case of a damper malfunction. Instructions for its use are on the side of the damper. Should the switch accidentally get turned off, the damper will still rotate to the open position when the thermostat calls for heat.

**FIG. A**  
**THIS IS CORRECT**

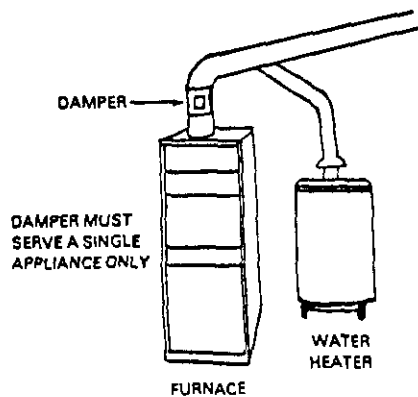

**FIG. B**  
**THIS IS NOT CORRECT**

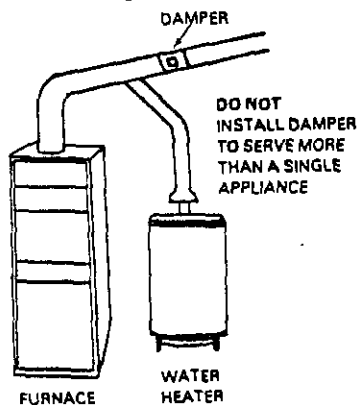

**PARTS LIST**  
**HI-BOY GAS FURNACES**

7/86

Part No.	Description	60,000 Heat	80,000 Heat	80,000 Heat/Cool	105,000 Heat	105,000 Heat/Cool	120,000 Heat/Cool	140,000 Heat/Cool	160,000 Heat/Cool	200,000 Heat
5601-004	Belt 39"									x
8552-002	Capacitor 5/370V			x		x	x			
8402-001	Fan and Limit 11"	x	x		x					
8402-007	Fan and Limit 8"									x
7003-004	Filter 16x25 P	x	x	x	x	x	x	x	x	x
9041-008	Heat Exchanger	x	x	x						
9041-009	Heat Exchanger				x	x	x			
9041-010	Heat Exchanger							x	x	
9041-023	Heat Exchanger									x
*	Housing - Blower 10-7	x	x	x	x					
*	Housing - Blower 10-9					x	x			
*	Housing - Blower 12-12									x
*	Housing - Blower 10-10							x	x	
5818-001	Manifold 3/4 NS2	x	x	x						
5818-002	Manifold 3/4 NS3				x	x	x			
5818-003	Manifold 3/4 NS4							x	x	
5818-004	Manifold 3/4 NS5									x
8102-005	Motor 1/6 hp	x	x		x					
8105-008	Motor 1/3 hp			x						
8106-001	Motor 1/2 hp									x
8105-009	Motor 1/3 hp					x	x			
8106-018	Motor 1/2 hp							x	x	
5153-005	Motor Adj. Bracket									x
8200-003	Motor Mount	x	x	x	x	x	x			
8200-028	Motor Mount							x	x	
5451-011	Motor Mounting Parts	x	x	x	x	x	x	x	x	
8402-042	Fan and Limit 11"			x		x	x	x	x	
9010-010	Orifice - Nat	x								
9010-008	Orifice - Nat		x	x			x		x	x
9010-009	Orifice - Nat				x	x	x	x	x	
8406-013	Micro Switch	x	x	x	x	x	x	x	x	x
8554-002	Pilot Burner - Nat	x	x	x	x	x	x	x	x	x
5501-012	Pulley - Blower 6 x 3/4									x
5501-015	Pulley - Motor 3 1/4 x 1/2									x
8407-006	Transformer	x	x		x					x
8201-007	Transformer w/Relay	x	x		x					x
8201-006	Trans.w/2 speed Relay			x		x	x	x	x	
5651-032	Valve - Nat. 1/2 x 3/4	x	x	x	x	x	x	x	x	x
9010-015	Venturi - 2 Cell	x	x	x						
9010-016	Venturi - 3 Cell				x	x				
9010-017	Venturi - 4 Cell							x	x	
9010-018	Venturi - 5 Cell									x
5152-004	Wheel - Blower DD9-7A	x	x		x					
5152-010	Wheel - Blower DD10-7A			x						
5152-014	Wheel - Blower DD10-9A					x	x			
5152-042	Wheel - Blower CL220									x
5152-015	Wheel - Blower DD10-10A							x	x	
8554-003	Thermocouple	x	x	x	x	x	x	x	x	x

\*Please order by model number.

Supersedes all previous lists, Subject to change without notice.

PARTS LIST  
ELECTRIC IGNITION  
HI-BOY GAS FURNACES

7/86

Part No.	Description	60,000 Heat	80,000 Heat	80,000 Heat/Cool	105,000 Heat	105,000 Heat/Cool	120,000 Heat/Cool	140,000 Heat/Cool	160,000 Heat/Cool	200,000 Heat
5601-004	Belt 39"									x
8552-002	Capacitor 5/370V			x		x	x			
8402-001	Fan and Limit 11"	x	x		x					
8402-042	Fan and Limit 11"			x		x	x	x	x	
8402-007	Fan and Limit 8"									x
7003-004	Filter 16x25 P	x	x	x	x	x	x	x	x	x
9041-008	Heat Exchanger	x	x	x						
9041-009	Heat Exchanger				x	x	x			
9041-010	Heat Exchanger							x	x	
9041-023	Heat Exchanger									x
*	Housing - Blower 10-7	x	x	x	x					
*	Housing-Blower 10-9					x	x			
*	Housing-Blower 10-10							x	x	
*	Housing-Blower 12-12									x
8600-002	Ignition Wire	x	x	x	x	x	x	x	x	x
5651-024	Ignition Module	x	x	x	x	x	x	x	x	x
5818-001	Manifold 3/4 NS2	x	x	x						
5818-002	Manifold 3/4 NS3				x	x	x			
5818-003	Manifold 3/4 NS4							x	x	
5818-004	Manifold 3/4 NS5									x
8102-005	Motor 1/6 hp	x	x		x					
8105-008	Motor 1/3 hp			x						
8106-001	Motor 1/2 hp									x
8105-009	Motor 1/3 hp					x	x			
8106-018	Motor 1/2 hp							x	x	
5153-005	Motor Adj. Bracket									x
8200-003	Motor Mount	x	x	x	x	x	x			
8200-028	Motor Mount							x	x	
5451-011	Motor Mounting Parts	x	x	x	x	x	x	x	x	
9010-010	Orifice - Nat	x								
9010-008	Orifice - Nat		x	x			x		x	x
9010-009	Orifice - Nat				x	x		x		
8406-013	Micro Switch	x	x	x	x	x	x	x	x	x
8554-009	Pilot Burner - Nat	x	x	x	x	x	x	x	x	x
5501-012	Pulley -Blower 6x3/4									x
5501-015	Pulley-Motor 3 1/2 x 1/2									x
8407-025	Transformer	x	x		x					x
8201-007	Transformer w/Relay	x	x		x					x
8201-006	Trans.w/2-speed Relay			x		x	x	x	x	
5651-023	Valve-Nat. 1/2 x 3/4	x	x	x	x	x	x	x	x	x
9010-015	Venturi - 2 Cell	x	x	x						
9010-016	Venturi - 3 Cell				x	x	x			
9010-017	Venturi - 4 Cell							x	x	
9010-018	Venturi - 5 Cell									x
5152-004	Wheel-Blower DD9-7A	x	x		x					
5152-010	Wheel-Blower DD10-7A			x						
5152-014	Wheel-Blower DD10-9A					x	x			
5152-042	Wheel-Blower CL220									x
5152-015	Wheel-Blower DD10-10A							x	x	

\*Please order by model number.

Supersedes all previous lists. Subject to change without notice.

PARTS LIST  
COUNTERFLOW GAS FURNACES

8/86

Part No.	Description	60,000 Heat	80,000 Heat	80,000 Heat/Cool	105,000 Heat/Cool	120,000 Heat/Cool	140,000 Heat/Cool	160,000 Heat/Cool
8402-046	Fan and Limit 11"	x	x	x	x	x		
8402-045	Fan and Limit 8"						x	x
7003-001	Filter 10x20 P				(2)	(2)	x	x
7003-003	Filter 15x20	x	x	x			x	x
9041-005	Heat Exchanger	x	x	x				
9041-006	Heat Exchanger				x	x		
9041-007	Heat Exchanger						x	x
*	Housing - Blower 10-7	x	x	x				
*	Housing - Blower 10-9				x	x		
*	Housing - Blower 10-10						x	x
8402-014	Limit Switch	x	x	x	x	x	x	x
5818-001	Manifold	x	x	x				
5818-002	Manifold				x	x		
5818-003	Manifold						x	x
8102-005	Motor 1/6 hp	x	x					
8105-008	Motor 1/3 hp			x				
8105-009	Motor 1/3 hp				x	x		
8106-018	Motor 1/2 hp						x	x
8200-003	Motor Mount	x	x	x	x	x		
8200-028	Motor Mount						x	x
5451-011	Motor Mounting Parts	x	x	x	x	x	x	x
9010-010	Orifice - Nat	x						
9010-008	Orifice - Nat		x	x		x		x
9010-009	Orifice - Nat				x		x	
8554-002	Pilot Burner	x	x	x	x	x	x	x
8406-013	Micro Switch	x	x	x	x	x	x	x
8554-003	Thermocouple	x	x	x	x	x	x	x
8407-006	Transformer	x	x					
8201-007	Transformer w/Relay	x	x					
8201-006	Transformer w/2-speed relay			x	x	x	x	x
5651-032	Valve - Nat 1/2 x 3/4	x	x	x	x	x	x	x
9010-015	Venturi 2-Cell	x	x			x		
9010-016	Venturi 3-Cell			x	x			
9010-017	Venturi 4-Cell						x	x
5152-004	Wheel - Blower DD9-7A	x	x					
5152-014	Wheel - Blower DD10-9A				x	x		
5152-010	Wheel - Blower DD10-7A			x				
5152-015	Wheel - Blower DD10-10A						x	x
8552-002	Capacitor 5/370V			x	x	x		

\*Please order by model number.

Supersedes all previous lists. Subject to change without notice.

PARTS LIST  
ELECTRIC IGNITION  
COUNTERFLOW GAS FURNACES

8/86

Part No.	Description	60,000 Heat	80,000 Heat	80,000 Heat/Cool	105,000 Heat/Cool	120,000 Heat/Cool	140,000 Heat/Cool	160,000 Heat/Cool
8552-002	Capacitor 5/370V			x	x	x		
8402-046	Fan and Limit 11"	x	x	x	x	x		
8402-045	Fan and Limit 8"						x	x
7003-001	Filter 10x20 P				(2)	(2)	x	x
7003-003	Filter 15x20 P	x	x	x			x	x
9041-005	Heat Exchanger	x	x	x				
9041-006	Heat Exchanger				x	x		
9041-007	Heat Exchanger						x	x
*	Housing - Blower 10-7	x	x	x				
*	Housing - Blower 10-9				x	x		
*	Housing - Blower 10-10						x	x
8600-002	Ignition Wire	x	x	x	x	x	x	x
8402-014	Limit Switch 140°	x	x	x	x	x	x	x
5818-001	Manifold	x	x	x				
5818-002	Manifold				x	x		
5818-003	Manifold						x	x
8406-013	Micro Switch	x	x	x	x	x	x	x
8102-005	Motor 1/6 hp	x	x					
8105-009	Motor 1/3 hp				x	x		
8105-008	Motor 1/3 hp			x				
8601-018	Motor 1/2 hp						x	x
8200-003	Motor Mount	x	x	x	x	x		
8200-028	Motor Mount						x	x
5451-011	Motor Mounting Parts	x	x	x	x	x	x	x
5651-024	Ignition Module	x	x	x	x	x	x	x
9010-010	Orifice - Nat	x						
9010-008	Orifice - Nat		x	x		x		x
9010-009	Orifice - Nat				x		x	
8554-009	Pilot and Orifice - Nat	x	x	x	x	x	x	x
8607-005	Terminal Block	x	x	x	x	x	x	x
8407-025	Transformer 20VA	x	x					
8201-006	Fan Relay w/Trans.			x	x	x	x	x
5651-023	Valve - Nat. 1/2 x 3/4	x	x	x	x	x	x	x
9010-015	Venturi 2-Cell	x	x	x				
9010-016	Venturi 3-Cell				x	x		
9010-017	Venturi 4-Cell						x	x
5152-004	Wheel DD9-7A (blower)	x	x					
5152-014	Wheel DD10-9A (blower)				x	x		
5152-015	Wheel DD10-10A (blower)						x	x
5152-010	Wheel DD10-7A (blower)			x				

\*Please order by model number.

Supersedes all previous lists. Subject to change without notice.

DANGER: ELECTRICAL SHOCK HAZARD,  
DISCONNECT POWER BEFORE SERVICING

CONNECTION DIAGRAM

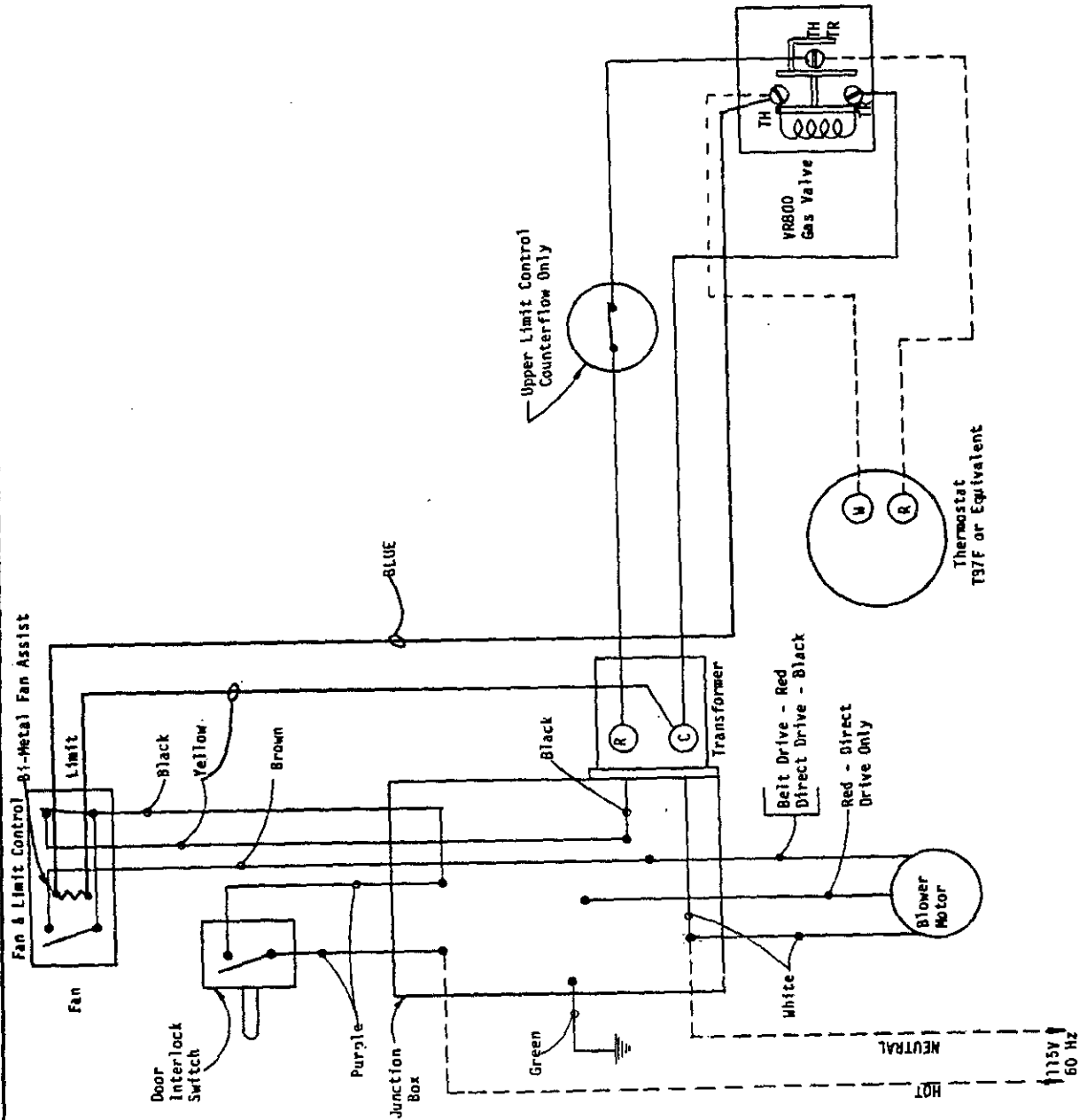

LADDER DIAGRAM

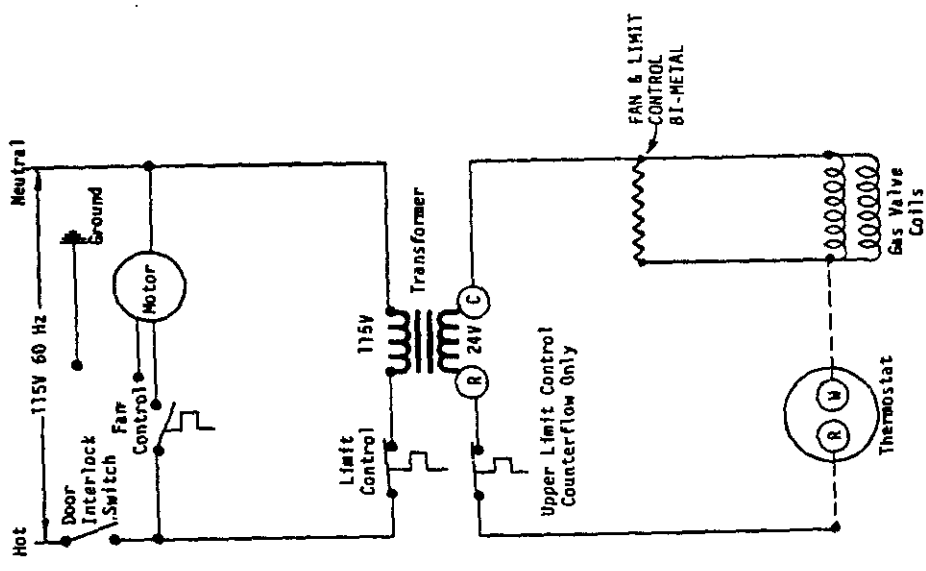

ALL MODELS, 1 & 2 SPEED, STANDING PILOT  
WIRING DIAGRAM 4046-100 C

IF ANY OF THE ORIGINAL WIRE AS SUPPLIED WITH THE APPLIANCE  
MUST BE REPLACED, IT MUST BE REPLACED WITH WIRING MATERIAL  
HAVING A TEMPERATURE RATING OF AT LEAST 105°F.

FACTORY WIRING ———  
FIELD WIRING - - - - -



**DANGER: ELECTRICAL SHOCK HAZARD;  
DISCONNECT POWER BEFORE SERVICING**

**CONNECTION DIAGRAM**

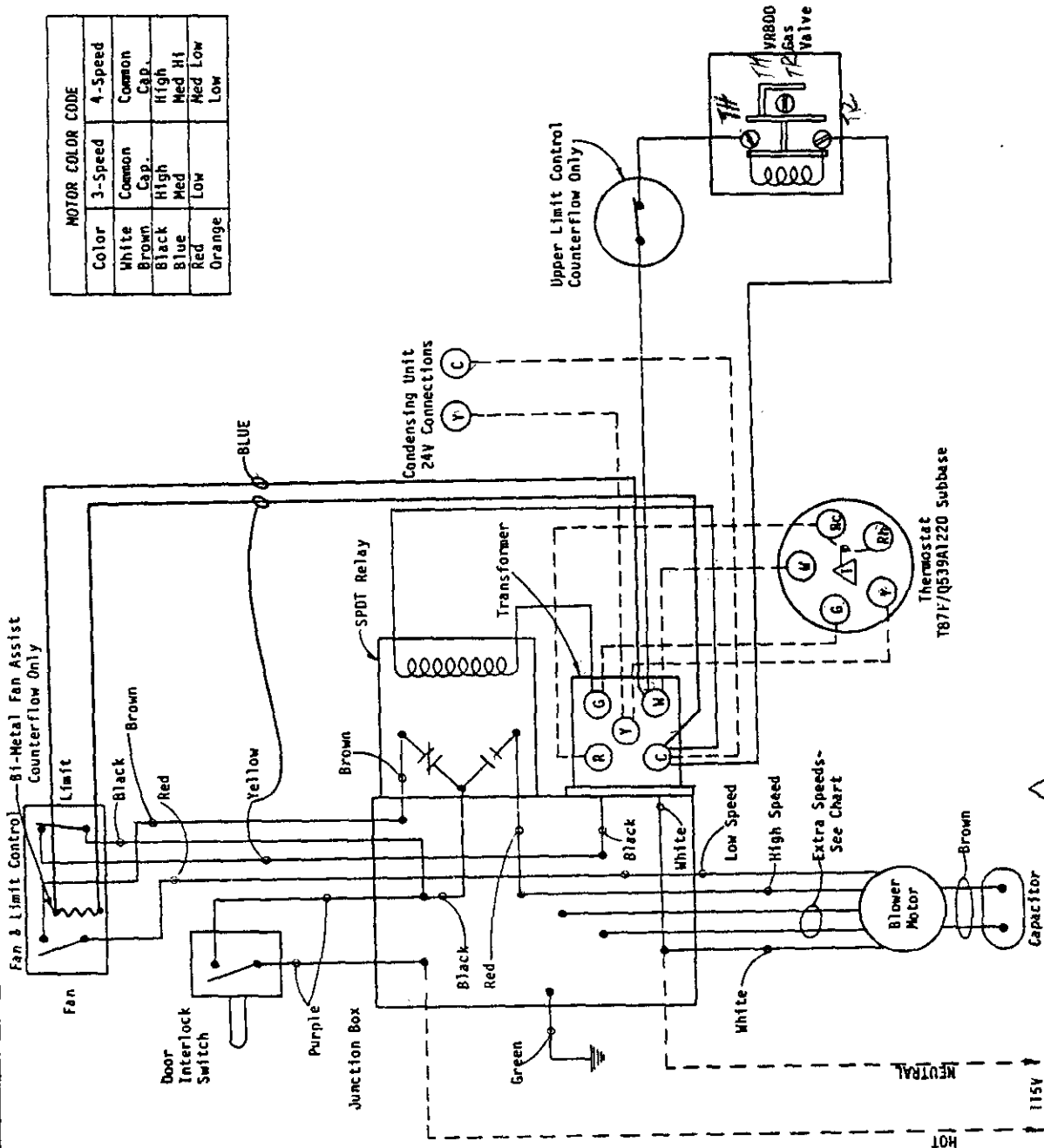

MOTOR COLOR CODE			
Color	3-Speed	4-Speed	
White	Common	Common	
Brown	Cap.	Cap.	
Black	High	High	
Blue	Med	Med	
Red	Low	Low	
Orange			

**LADDER DIAGRAM**

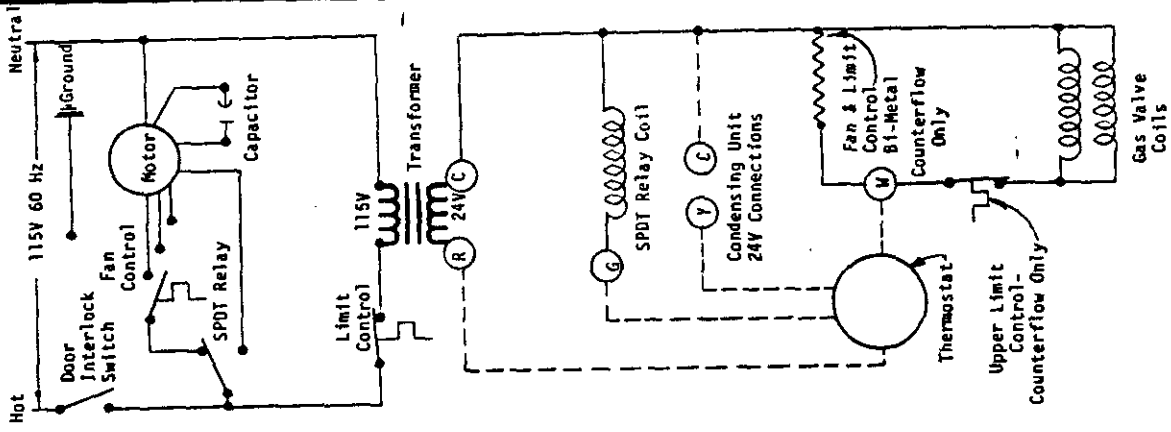

IF ANY OF THE ORIGINAL WIRE AS SUPPLIED WITH THE APPLIANCE MUST BE REPLACED, IT MUST BE REPLACED WITH WIRING MATERIAL HAVING A TEMPERATURE RATING OF AT LEAST 105° C.

1 Jumper Rc-Rh required on Q539A1220

FACTORY WIRING  
FIELD WIRING

ALL MODELS, 3 and 4 SPEED, STANDING PILOT  
WIRING DIAGRAM  
4046-101C

