

INSTALLATION AND OPERATING INSTRUCTIONS  
FOR GAS FIRED FURNACES

APPLICATION

This is a forced air gas furnace for installation in building constructed on site or manufactured building with furnace installed at final site. The furnace installation must conform with local building codes and ordinances or, in their absence with the National Fuel Gas Code, ANSI Z223.1-1974 and the National Electrical Code, ANSI C1-1978 (NFPA No. 70-1978). It is the personal responsibility and obligation of the purchaser to contract a qualified installer to assure that installation is adequate and is in conformance with governing codes and ordinances.

HIGH ALTITUDE APPLICATIONS

Input ratings and bonnet capacities shown in the specification sheets are for elevations up to 2000 feet. For elevations above 2000 feet, ratings should be reduced at the rate of four percent for each 1000 feet above sea level (Ref. ANSI Z223.1, 1974 Appendix 1-C).

TRANSPORTATION DAMAGE

All units are packed securely in shipping container. All units should be carefully inspected upon arrival for damage. In the event of damage, the consignee should:

1. Note on delivery receipt of any damage to container.
2. Notify carrier promptly, and request an inspection.
3. In case of concealed damage, the carrier must be notified as soon as possible within 15 days after delivery.
4. Claims for any damage, apparent or concealed, should be filed with the carrier, using the following supporting documents, and within the 9-month statute of limitations.
  - a. Original Bill of Lading, certified copy, or indemnity bond.
  - b. Original paid freight bill or indemnity in lieu thereof.
  - c. Original invoice or certified copy thereof showing trade and other discounts or deductions.
  - d. Copy of the inspection report issued by carrier's representative at the time damage is reported to carrier.

The carrier is responsible for making prompt inspection of damage and for a thorough investigation of each claim.

LOCATING THE FURNACE

When selecting a location for the furnace, observe the following points:

1. The furnace should be set on a level floor. If the floor may become damp or wet at times, the furnace should be supported above the floor using a concrete base, bricks, patio blocks, etc., making sure adequate support is available for the furnace. C-Series counterflow furnaces require use of Combustible Floor Base if installed on combustible surface. The Combustible Floor Base is not part of the furnace and must be ordered separately. Models G127, G127E, G152 and G152E are not approved for installation on combustible flooring.
2. The furnace should be as centralized as practical with respect to the air distribution system.
3. Provisions must be made for venting combustion products outdoors through an individual venting system.
4. Provide at least the minimum clearances specified in Fig. 1 for fire protection, proper operation and service access. These clearances must be permanently maintained. The combustion and ventilating air openings in the front of the furnace must never be obstructed.

5. Minimum service clearances must take precedence over fire protection clearances (minimum installation clearances).
6. All models except the G-Series are approved for a utility room or closet installation. The G-Series is approved for an alcove installation only (enclosed on three sides only, front open).

FIG. 1 — MINIMUM CLEARANCES

MODEL	MINIMUM INSTALLATION CLEARANCES					MINIMUM SERVICE CLEARANCES			
	TOP	FRONT	FLUE	BACK	SIDES	FLOOR	FRONT	SIDES	BACK
H1610Z, H1610M, H1502E, H1502M, H1510Z, H1510M	1	6	6	6	1	C	24		
H100E, H100M, H1000E, H1000M, H1110E, H1110M, H1115E, H1115M, H1415E, H1415M	1	4	5	0	0	C	24		
H2015E, H2015M	1	5	6	1	1	C	24		
G150M, G150E, G152M, G152E	1	5	6	0	6	NC	24		
G10E, G10M, G120E, G120M, G121E, G121M, G140E, G140M, G141E, G141M, G142E, G142M	1	4	6	0	2	NC	24		
G101, G101E, G127, G127E, G152, G152E	1	Alcove	6	1	1	NC	24	10	24

▲ All clearances are in inches.  
 ▲ If Type B-1 vent is used.  
 ▲ If Type B-1 vent is used.  
 ▲ On these E-Series models, reduced clearances per notes ▲ and ▲ do not apply if vent damper is used.

▲ If data ▲ applies.  
 ▲ Minimum clearance at least one side for access to rear of furnace.  
 C - Floor may be combustible material.  
 NC - Floor must be non-combustible.

DUCT WORK

The air distribution system should be designed and installed in conformance with Manuals 7 or 7A published by Air Conditioning Contractors of America (ACCA), as set forth in their Manual K.

**WARNING**

When a furnace is installed so that supply ducts carry air circulated by the furnace to areas outside the space containing the furnace, the return air must also be handled by a duct(s) sealed to the furnace casing and terminating outside the space containing the furnace. This is to prevent drawing possible hazardous combustion products to the circulated air.

When the furnace is used in connection with a cooling unit, the furnace shall be installed parallel with or on the upstream side of the cooling unit to avoid condensation in the heating element. With a parallel flow arrangement, the dampers or other means used to control flow of air shall be adequate to prevent chilled air from entering the furnace and, if manually operated, must be equipped with means to prevent operation of either unit, unless the damper is in the full heat or cool position.

## COMBUSTION AND VENTILATION AIR

The furnace and furnace room must have an adequate supply of air for safe combustion and ventilation. The provisions necessary to assure an adequate air supply will vary depending upon differences in the tightness of house construction and in the location of the furnace. Methods of providing air from some typical situations are described below. Consult local codes and ordinances for requirements applicable to your specific furnace installation conditions and comply with them. In the absence of local codes and ordinances, comply with the National Fuel Gas Code, ANSI Z223.1-1974.

### EXAMPLE 1 — FURNACE LOCATED IN AN UNCONFINED SPACE

- A. If the furnace is located in a basement or other large, open area of a conventionally built house (loose construction), the air that leaks into the building normally will provide an adequate air supply.
- B. If the furnace is located in a tightly constructed building (storm windows, weather stripping, cracks caulked, etc.) an outdoor air intake must be provided. Example 2, Section B, shows a typical method.

### EXAMPLE 2 — FURNACE LOCATED IN A CONFINED SPACE

- A. When the furnace is in a closet or utility room, install two open grilles in a wall or door opening to the rest of the house. Each grille must have a free area of at least one square inch for each 1000 Btu/h of total input rating of all gas appliances in the confined space. Refer to Fig. 2. The grilles must communicate with other open areas having adequate air infiltration from outdoors.
- B. If the building is tightly constructed, not enough outside air may enter for safe combustion. Install a fresh air duct from a point near the burners to the outside or to a ventilated attic or crawl space. Refer to Fig. 3. This duct must have a free area of at least one square inch for each 4000 Btu/h of total input of all gas appliances in the space. The minimum dimension of a rectangular duct must not be less than three inches.

**CAUTION:** WHEN A FURNACE IS INSTALLED IN A CLOSET OR UTILITY ROOM, NEVER USE THIS ROOM AS A RETURN AIR PLenum.

FIG. 2 — FURNACE LOCATED IN CONFINED SPACE

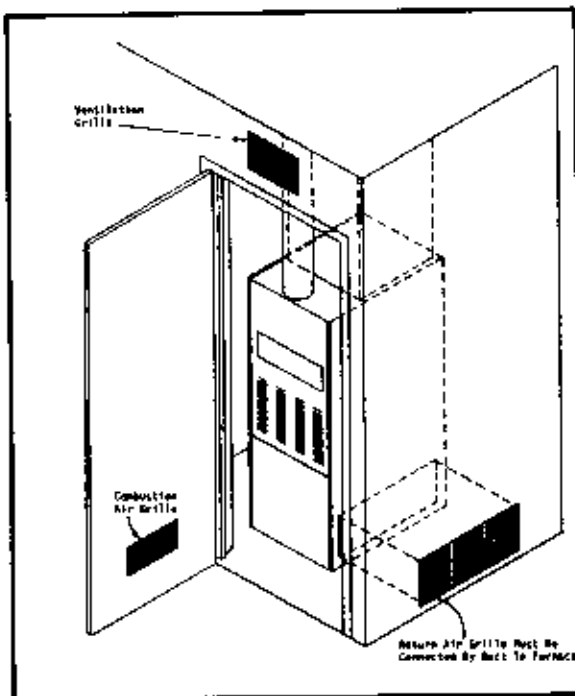
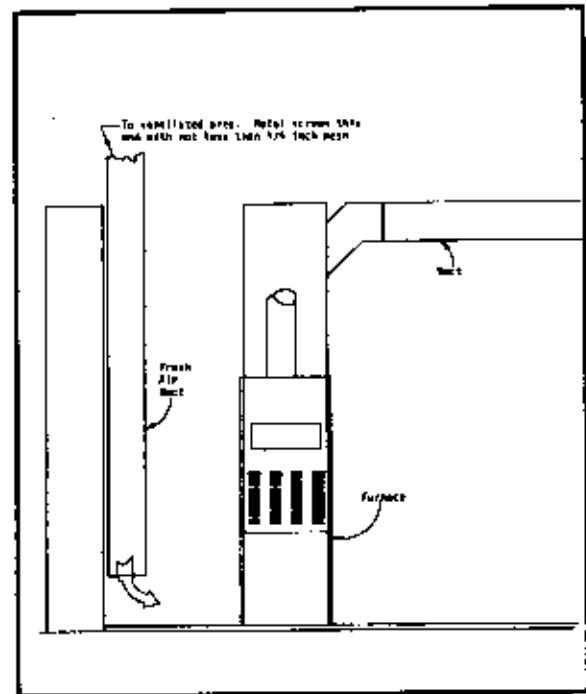

FIG. 3 — FRESH AIR DUCT FOR TIGHTLY SEALED BUILDING



### FLUE PIPE CONNECTION

This furnace must be vented either directly to the outside or connected into a suitable masonry chimney. The vent must be installed in compliance with the National Fuel Gas Code (ANSI Standard Z223.1-1974) and these instructions.

### GENERAL INSTRUCTIONS:

1. The flue pipe must be the same size as the outlet of the draft diverter hood.
2. Maintain a minimum clearance of 6 inches (1 inch for Type B-1) between the flue pipe and any adjacent combustible materials. This rule applies whether the flue is enclosed or installed in the open; is horizontal or vertical, or passes through floors, walls, roofs, or furred out spaces. Joists, studs, floors dry wall, sheathing, rafters, roofing and other materials classified as combustible must not be closer than 6 inches (1 inch for Type B-1) to the flue.
3. Where two appliances vent into a common flue, the area of the common flue should equal the sum of the areas of the individual flue pipes.
4. If connected into a chimney, the flue pipe must be inserted into, but not beyond the inside wall of the chimney.
5. The gas vent must extend at least 2 feet above the highest point where it passes through the roof of a building (3 feet for a chimney) and at least 2 feet higher than any portion of a building within a horizontal distance of 10 feet. See Fig. 4.
6. The flue pipe system shall be installed so as to avoid excessive turns which create unnecessary resistance to flow of vent gases.
7. Horizontal runs shall be as short and direct as possible. The maximum length of a single-wall flue pipe shall not exceed 75 percent of the height of the vent system. The maximum length of a Type B-1 double wall flue connection shall not exceed 100 percent of the height of the vent system.
8. All horizontal vent pipes shall be pitched upward from the furnace at least 1/4 inch per foot.
9. All vent systems shall be adequately supported to maintain proper clearances, to prevent physical damage, and to prevent separation of the joints.
10. Vents passing through a combustible wall or partition must use a ventilated wall thimble. See Fig. 5.
11. Vents passing through floors or ceilings must be fire-stopped. See Fig. 6 and Fig. 7.

FIG. 4 — CHIMNEY OR VENT CAP INSTALLATION

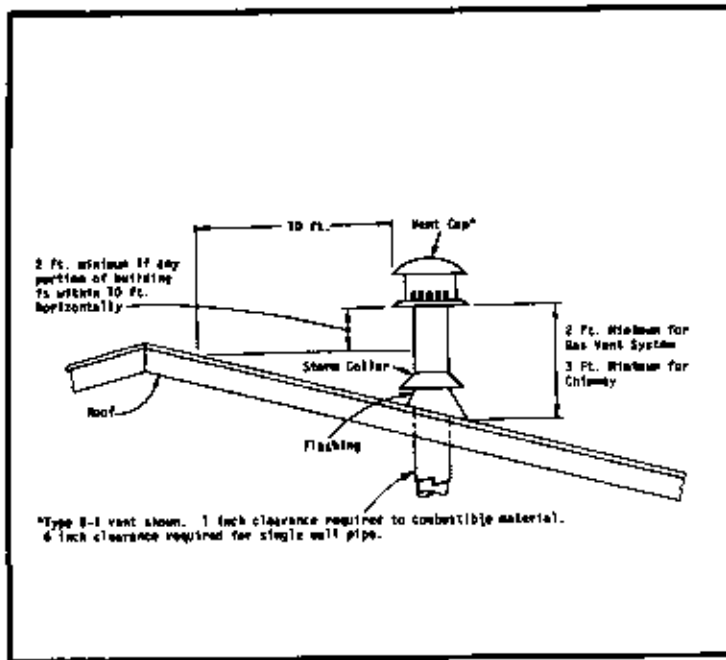

FIG. 6 — VENT THROUGH FLOOR

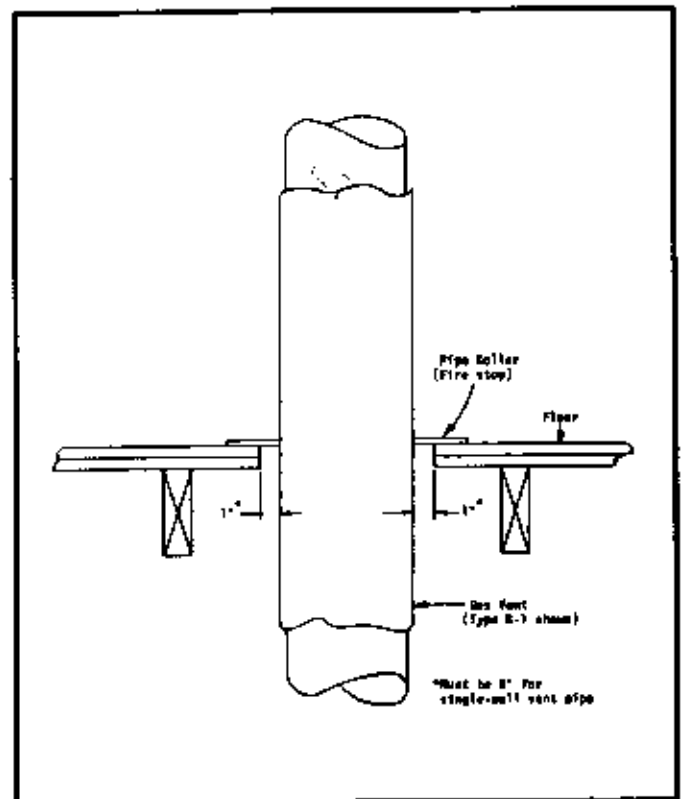

FIG. 5 — HORIZONTAL VENTING, COMBUSTIBLE WALL

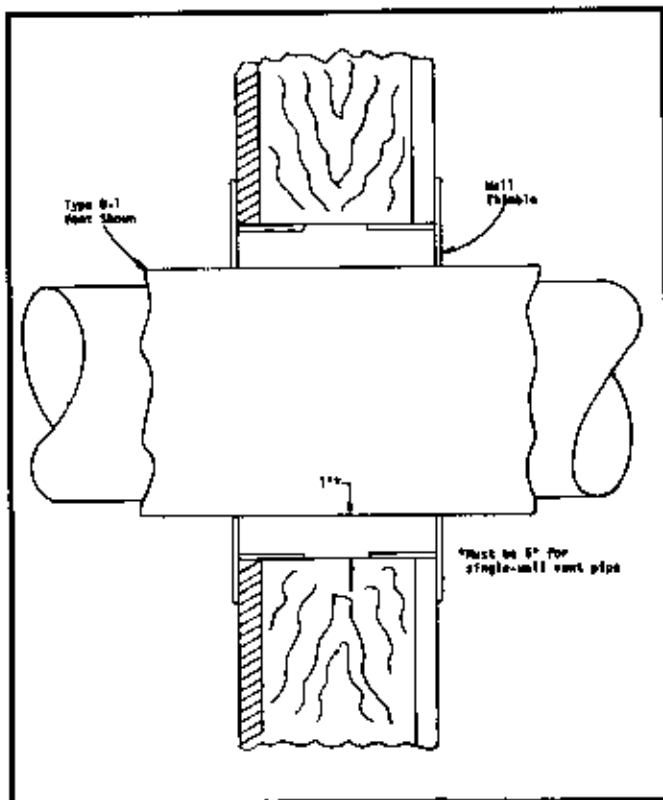
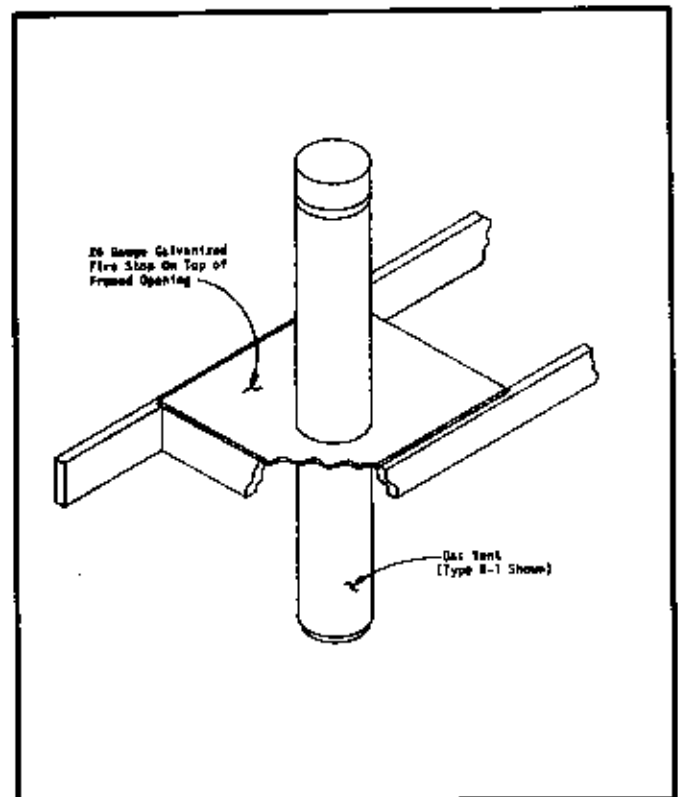

FIG. 7 -- VENT THROUGH CEILING



**GAS SUPPLY AND PIPING**

**GENERAL RECOMMENDATIONS**

1. Be sure the gas line complies with the local codes and ordinances, or in their absence with National Fuel Gas Code, ANSI Z223.1-1974.
2. A sediment trap or drip leg must be installed in the supply line to the furnace.
3. A ground joint union shall be installed in the gas line adjacent to and upstream from the gas valve and downstream from the manual main shut off valve.
4. A 1/8" N.P.T. plugged tapping accessible for test gauge connection shall be installed immediately upstream of the gas supply connection to the furnace for the purpose of determining the supply gas pressure.
5. A manual shut-off valve shall be installed in the supply gas line external to the furnace.
6. Use steel or wrought iron pipe and fittings.
7. DO NOT thread pipe too far. Valve distortion or malfunction may result from excess pipe within the control. Use pipe joint compound resistant to the action of Liquefied Petroleum gases on male threads only. DO NOT use Teflon tape. See illustrations below.

**LENGTH OF STANDARD PIPE THREADS (Inches)**

PIPE SIZE	EFFECTIVE LENGTH OF THREAD	OVERALL LENGTH OF THREAD
3/8	3/8	9/16
1/2	1/2	3/4
3/4	1/2-9/16	13/16
1	9/16	1

**FIG. 9 — TYPICAL PIPING FOR H-SERIES AND C-SERIES**

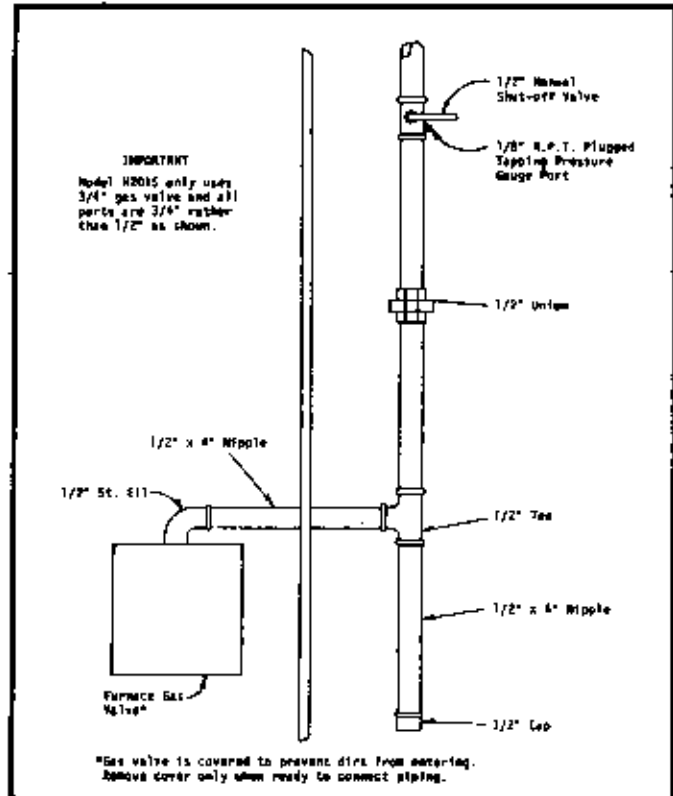

**FIG. 10 — TYPICAL PIPING FOR G-SERIES**

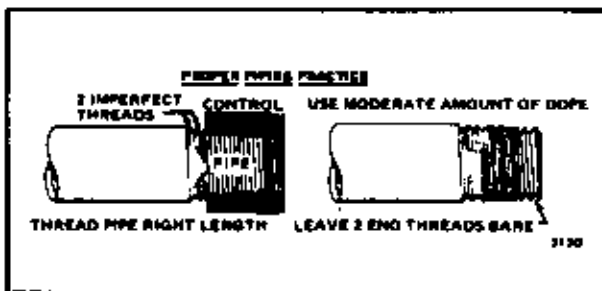
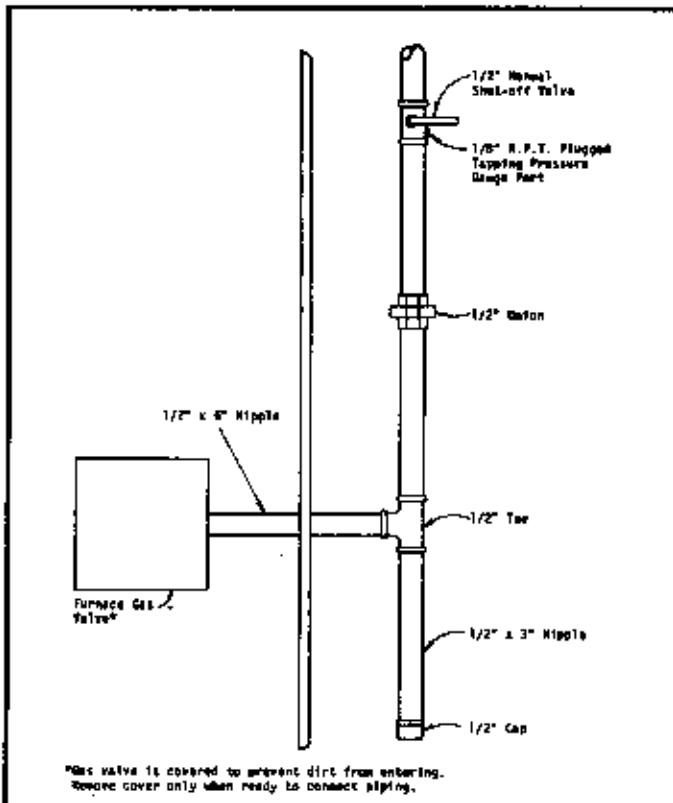

8. Refer to Fig. 8 for Gas Pipe sizes for natural gas. If more than one appliance is supplied from a single line size, capacity must equal or exceed the combined input to all appliances, and the branch lines feeding the individual appliances properly sized for each input.

**FIG. 8 — GAS PIPE SIZES — NATURAL GAS**

Length Of Pipe, Ft.	Pipe Capacity — Btu Per Hour Input			
	Pipe Size			
	1/2"	3/4"	1"	1-1/4"
10	132,000	278,000	520,000	1,050,000
20	92,000	190,000	350,000	730,000
30	71,000	152,000	285,000	590,000
40	63,000	130,000	245,000	500,000
50	56,000	115,000	215,000	440,000
60	50,000	105,000	195,000	400,000
70	46,000	96,000	180,000	370,000
80	43,000	90,000	170,000	350,000
100	38,000	79,000	150,000	305,000

## CHECKING THE GAS PIPING

Before turning gas under pressure into piping, all openings from which gas can escape should be closed. *Immediately after turning on gas*, the system should be checked for leaks. This can be done by watching the 1/2 cubic foot test dial and allowing 5 minutes to show any movement, and by soaping each pipe connection and watching for bubbles. If a leak is found, make the necessary repairs immediately and repeat the above test.

Defective pipes or fittings should be replaced and not repaired. *Never use a flame or fire in any form to locate gas leaks, use a soap solution.*

After the piping and meter have been checked completely, purge the system of air. **DO NOT** bleed the air inside the furnace. Be sure to relight all the gas pilots on other appliances that may have been extinguished because of interrupted gas supply.

## WIRING

**WARNING**

For your personal safety, turn off electric power at service entrance panel before making any electrical connections.

All electrical work must conform with local codes and ordinances or, in their absence, with the National Electrical Code, ANSI C1-1978.

### ELECTRICAL POWER SUPPLY

Run a separate 120 volt, 15 ampere, 60 Hz, AC circuit from a separate fuse or circuit breaker in the service entrance panel. Locate a shut off switch at the furnace. Make connections from this switch to furnace junction box as shown in the furnace wiring diagram.

### ELECTRICAL GROUNDING

#### A. RECOMMENDED GROUNDING METHOD

Permanently ground this furnace in accordance with the National Electrical Code or local codes and ordinances. Use a #14 AWG copper wire from grounding lug or green ground wire on the furnace to a grounded connection in the service panel or a properly driven and electrically grounded ground rod.

#### B. ALTERNATE GROUNDING METHOD

If the recommended grounding method is impossible, permanently ground the furnace from the ground connector to a grounded cold water pipe\* using a separate, green colored, insulated conductor of appropriate size. **THIS, HOWEVER, IS NOT RECOMMENDED.**

\*Cold water pipe must have metal continuity to electrical ground and not be interrupted by plastic, rubber or other electrically insulating connectors (including water meter or pump) without adding a jumper wire at these connections.

**NOTE: DO NOT ground to a gas supply pipe. DO NOT connect to electric power supply until appliance is permanently grounded.**

### THERMOSTAT

Install the thermostat in accordance with instructions packed with it. Locate the thermostat 4-1/3 feet from the floor on an inside wall away from drafts, warm air registers and floor or table lamps. Refer to furnace wiring diagrams for connections.

All 24V wall thermostats have heat anticipators to compensate the thermostat for various system controls and allow the best possible cycle rates. Some anticipators are fixed and require no adjustment. However, the majority of wall thermostats have adjustable anticipators and do require adjustment to match the current rating the gas valve. Most gas valves currently used are rated at .60, but check the rating of the valve on the furnace being installed to be sure.

Failure to adjust the anticipator lever to correspond to the actual current draw through the thermostat will cause severe short cycling if set too low and room temperature may never attain the thermostat set point, and if set too high, will cause room temperature to overshoot the set point.

### BLOWER OPERATION

All G-Series models employ a combination fan-limit control with a manual blower switch allowing continuous fan operation if desired.

All three and four speed direct drive models are equipped with a heating-cooling blower relay, and when matched with the appropriate wall thermostat offers manual blower operation from the wall thermostat for air circulation.

Heating only models have no provisions for continuous air circulation, and blower operates only upon demand from combination fan-limit control based upon temperature in the heat exchanger compartment.

**NOTE:** On standing pilot models, it is recommended that the pilot flame be turned off on all air conditioning applications during the period when the air conditioner is expected to be operating the majority of the time (summer operation).

### FIELD INSTALLED EQUIPMENT

Wiring to be done in the field between the furnace and devices not attached to the furnace, or between separate devices which are field installed and located, shall conform with the temperature limitation for Type T wire [61°F rise (36°C)] when installed in accordance with the manufacturer's instructions. Refer to wiring diagrams, pages 9-12.

### FILTERS

All models are shipped with filters. See Fig. 11 for sizes. H-Series and G-Series have the filters in their intended positions (E-Series can be installed on either side). The C-Series models require a bracket installation and final filter location projects into return air plenum attachment to furnace. See Fig. 12 and Fig. 13.

FIG. 11

FILTER SIZES FOR GAS FURNACES		
MODEL		SIZE
H815D2, H815D2E	(1)	16 x 25
H815D2, H815D2E	(1)	16 x 25 P
H815D3, H815D3E	(1)	16 x 25
H1065, H1065E	(1)	16 x 25 P
H1065D2, H1065D2E	(1)	16 x 25
H1065D3, H1065D3E	(1)	16 x 25 P
H1215, H1215E	(1)	16 x 25 P
H1215D4, H1215D4E	(1)	16 x 25 P
H1415, H1415E	(1)	16 x 25 P
H1615, H1615E	(1)	16 x 25 P
H2015, H2015E	(2)	16 x 25 P
C615D2, C615D2E	(1)	15 x 20 P
C815D2, C815D2E	(1)	15 x 20 P
C1065, C1065E	(1)	18 x 20
C1065D3, C1065D3E	(1)	15 x 20
C1215, C1215E	(1)	15 x 20
C1415, C1415E	(1)	15 x 20
C1615, C1615E	(1)	15 x 20
G101, G101E	(1)	20 x 20 x 1
G127, G127E	(1)	20 x 25 x 1
G152, G152E	(2)	16 x 25 x 1

P = Permanent, otherwise are throwaway type.

## MAINTENANCE INSTRUCTIONS

The furnace and its vent system should be inspected annually by a qualified service agency, generally prior to the heating season.

**NOTE: PRIOR TO THE START OF ANY OF THE FOLLOWING MAINTENANCE PROCEDURES SHUT OFF ALL POWER TO THE UNIT.**

Routine maintenance procedures are the responsibility of the owner and are contained in the Owner's Manual. These are briefly outlined below:

1. **Air Filters.** Check the condition on at least a monthly basis when the furnace is in use or replace whenever it is necessary.
2. **Lubrication Requirements.** Direct drive motors are permanently lubricated, no maintenance required. Belt drive motors and blower bearings should be oiled twice per heating season (every two months if CAC, constant air circulation, is used) with 5-6 drops SAE20 motor oil. **DO NOT OVER OIL.**
3. **Fan Belt Adjustment.** Check and adjust if necessary for proper tension, approximately one inch depression with light pressure. Replace belt if cracked or frayed.
4. **Basic Examination of Furnace.** Visual inspection of pilot flame (if standing pilot model) and the main burners. Also inspection of the burner compartment and the draft diverter area for sooting and scaling.
5. **Periodic Inspection of the Vent System.** Visual inspection of the vent system from the furnace to the chimney for any leaking or defective parts.

### SERVICE AGENCY PROCEDURES

1. If the furnace is a standing pilot model (burns the time), observe the pilot flame. The pilot flame should be a "soft blue flame" enveloping or covering approximately 1/2 inch of the tip of the thermocouple.

FIG. 14

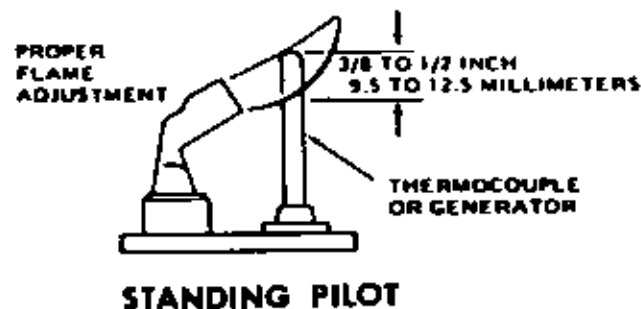

On intermittent pilot models, the pilot lights only when the thermostat calls for heat and the main burner lights within a few seconds thereafter. It is recommended that any observation of pilot or main burner operation be done only with the burner compartment door in place and viewing through the combustion air slots.

The pilot flame can be adjusted by removing the pilot adjustment cover screw. Turn inner adjustment screw clockwise to decrease and counterclockwise to increase pilot flame. Be sure to replace cover screw after adjustment to prevent possible gas leakage.

FIG. 15

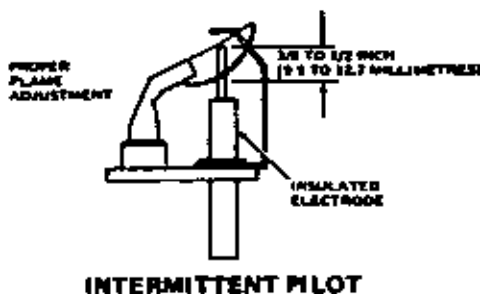

2. Observe the main burners in operation, viewing through the combustion air slots. The flame should be mostly "blue" with possibly a little orange (not yellow) at the tips of the flames. The flames should be in the center of the heat exchanger compartments and not impinging on the heat exchanger surfaces themselves.

Observe the fire until the blower starts (there is a normal delay period until the heat exchanger warms up). There should be no change in the size or shape of the flame. If there is any wavering or blowing of the flame on blower start-up, it is an indication of a possible leak in the heat exchanger.

The air shutter on the burner(s) should be closed until "yellow" tips show in the burner flame, then opened slowly until the "yellow" tips just disappear. Then, lock the air shutter in place by means of the lock nut or set screw.

Make the final adjustment after several minutes of burner operation to assure any dust is not adding color to the flame and make it more difficult to determine yellow tipping of the burner flame.

FIG. 16 — BURNER AIR SHUTTER ADJUSTMENT

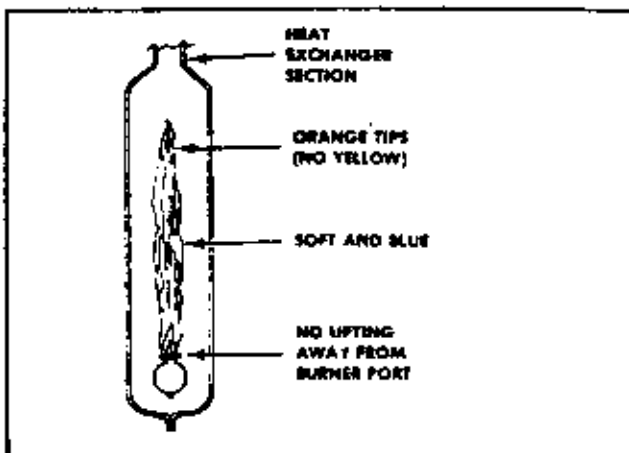

H-SERIES AND C-SERIES  
(Multiple Section Type)

FIG. 17 — BURNER AIR SHUTTER ADJUSTMENT

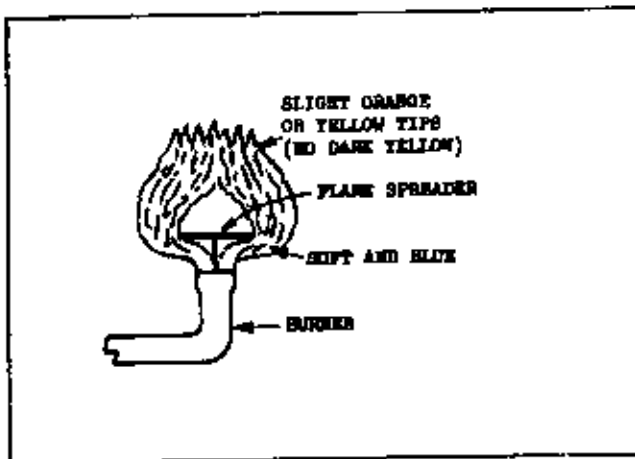

G-KERINS  
(Single Port Burner)

**NOTE: DANGER OF PERSONAL INJURY HAZARD. DISCONNECT POWER BEFORE SERVICING AND TURN OFF MANUAL GAS VALVE.**

3. Remove and inspect burners for lint and dirt accumulation and any evidence of deterioration from corrosion, cracking or other causes. Clean with a long handled brush. Replace any damaged burners.
4. Inspect the combustion chamber and flue passages annually. Look for soot and any evidence of deterioration due to corrosion, cracking or other cause. Use a good light to look up into the section(s) above the burner(s). A small mirror is helpful. If passages are sooted or appear deteriorated, follow the procedure below:
  - a. Make sure gas and electric power supply is off.
  - b. Break the gas pipe union. Remove gas manifold and burner assembly.
  - c. Disconnect vent pipe from the top of the draft diverter.
  - d. Remove the upper door, exposing the draft diverter.
  - e. Remove the draft diverter.
  - f. On multiple section furnaces, remove the restrictor plate and the flue baffles.
  - g. Clean heat exchanger section(s) using long handled wire brush and vacuum cleaner. Clean the top section first, then clean upwards from the combustion chamber.
  - h. Replace parts in reverse order. Check pilot burner or ignitor/sensor for proper alignment. See Fig. 14 and 15 for reference.
  - i. Reinstall burner manifold. Reconnect gas line and wiring.
  - j. Turn gas on. Check for leaks. Turn power on.
  - k. Refer to lighting instructions. Check for proper operation.

#### REPLACEMENT PARTS

Replacement parts for the gas furnaces are available through local distributor.

Parts lists covering all of the normally serviceable items are shown on pages 13-15. When ordering parts or making inquiries pertaining to any of the furnaces covered by these instructions, it is very important to always supply the COMPLETE model number and serial number of the furnace. This is necessary to assure that the correct parts (or an approved alternate part) are issued to the service agency.

**CONNECTION DIAGRAM**

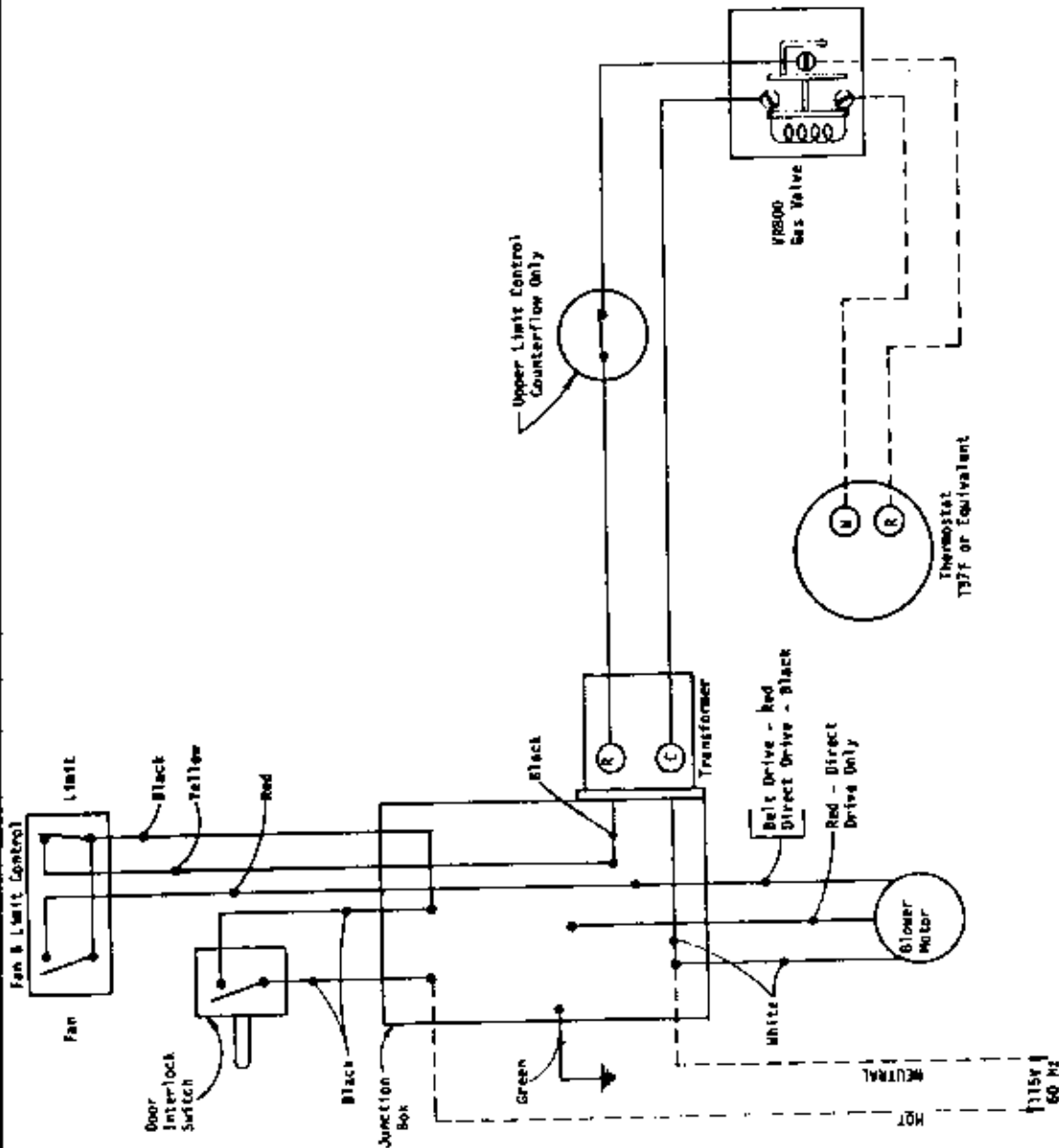

IF ANY OF THE ORIGINAL WIRE AS SUPPLIED WITH THE APPLIANCE MUST BE REPLACED, IT MUST BE REPLACED WITH WIRING MATERIAL HAVING A TEMPERATURE RATING OF AT LEAST 105°C.

Factory Wiring  
Field Wiring

**LADDER DIAGRAM**

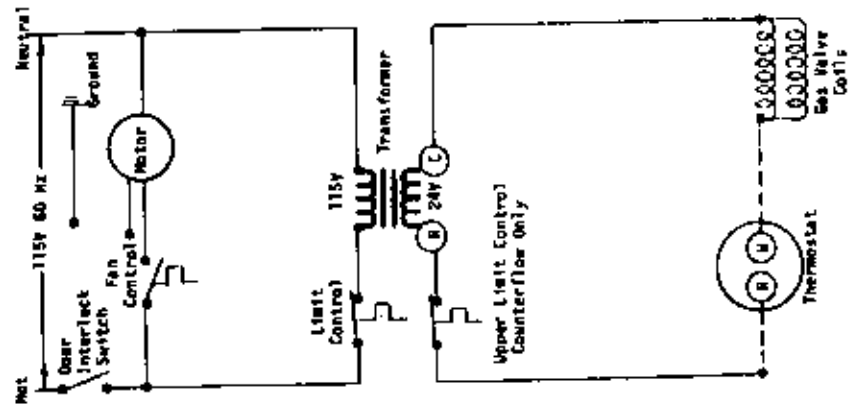

ALL MODELS, 1 & 2 SPEED, STANDING PILOT  
WIRING DIAGRAM 4046-100



**DANGER: ELECTRICAL SHOCK HAZARD.  
DISCONNECT POWER BEFORE SERVICING.**

**CONNECTION DIAGRAM**

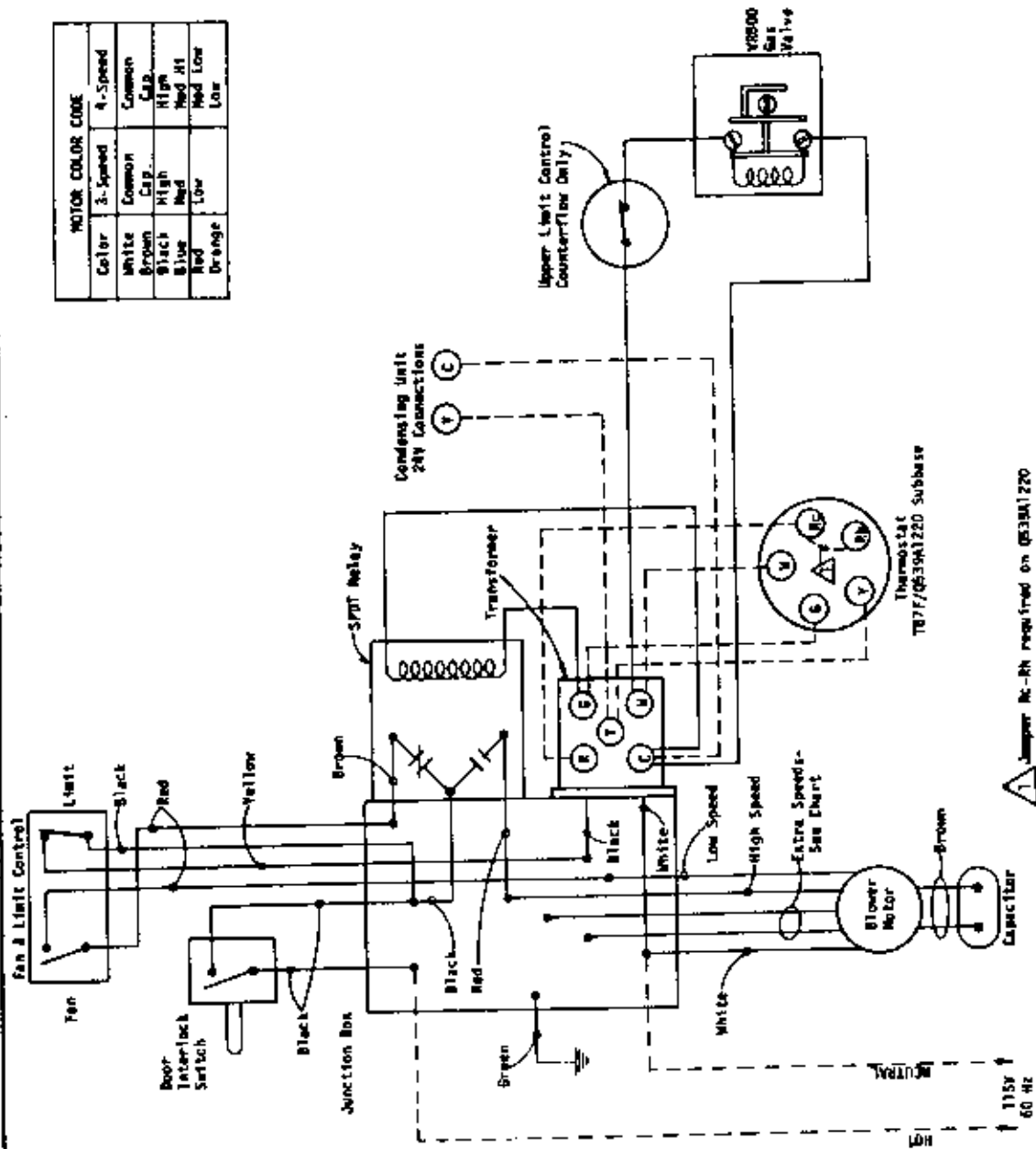

MOTOR COLOR CODE	
Color	3-Speed
White	Common
Brown	Cap.
Black	High
Blue	Med. HI
Red	Low
Orange	Med. Low
	Low
	Common
	Cap.
	High
	Med. HI
	Low
	Med. Low
	Low

Factory Wiring  
Field Wiring

IF ANY OF THE ORIGINAL WIRE AS SUPPLIED WITH THE APPLIANCE MUST BE REPLACED, IT MUST BE REPLACED WITH WIRING MATERIAL HAVING A TEMPERATURE RATING OF AT LEAST 105°C.

C-SERIES, M-SERIES, 3 & 4 SPEED STANDING PILOT  
WIRING DIAGRAM 4046-101

**DANGER: ELECTRICAL SHOCK HAZARD.  
DISCONNECT POWER BEFORE SERVICING.**

**CONNECTION DIAGRAM**

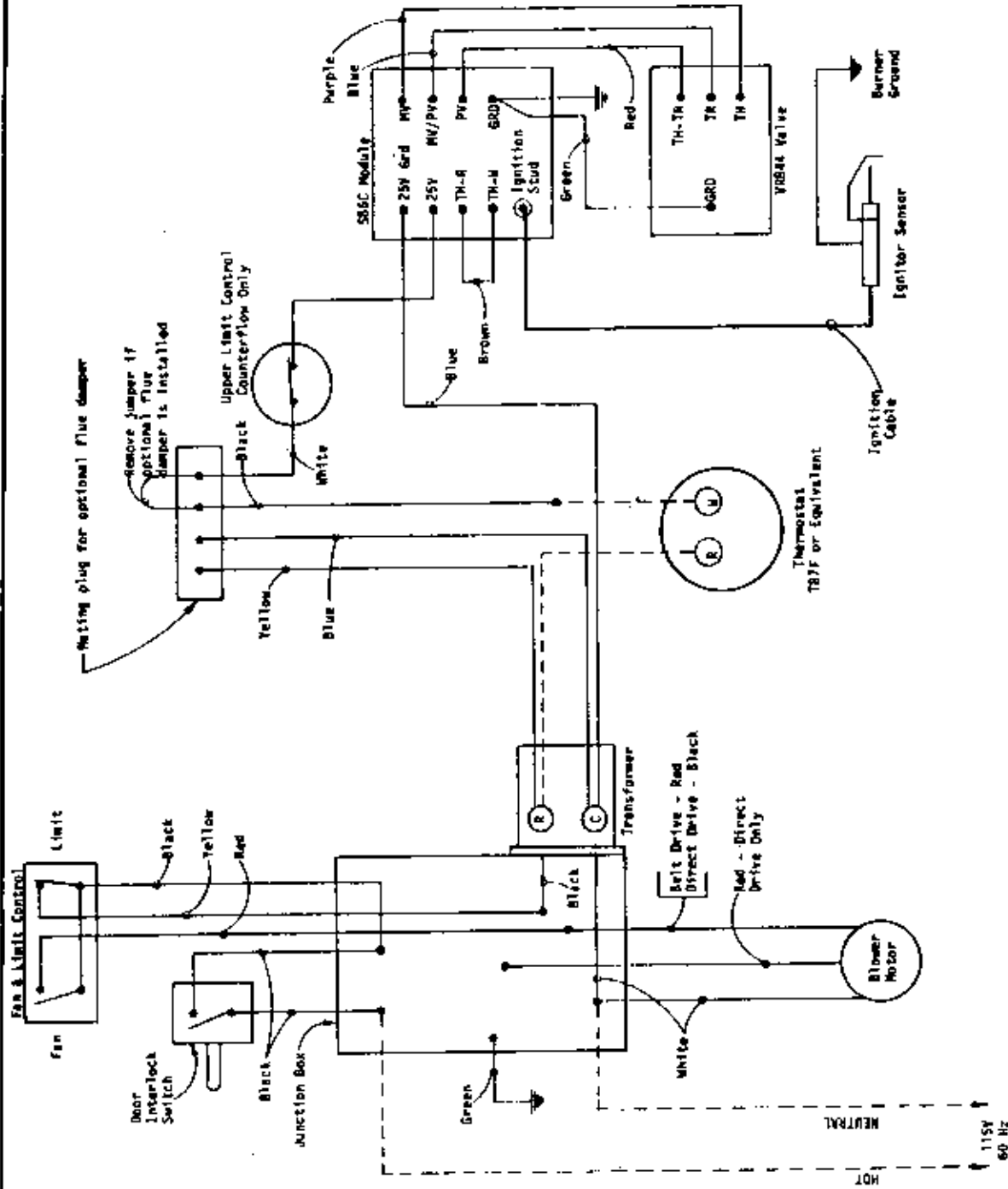

Factory Wiring \_\_\_\_\_  
Field Wiring - - - - -

IF ANY OF THE ORIGINAL WIRE AS SUPPLIED WITH THE APPLIANCE  
MUST BE REPLACED, IT MUST BE REPLACED WITH WIRING MATERIAL  
HAVING A TEMPERATURE RATING OF AT LEAST 105°C.

**LADDER DIAGRAM**

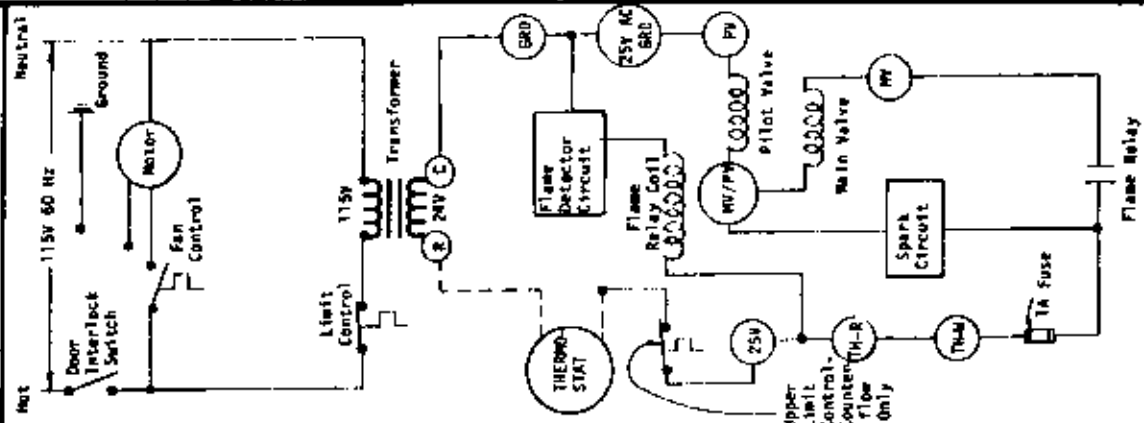

1 & 2 SPEED MODELS, ELECTRIC IGNITION  
WIRING DIAGRAM 4046-102

**CONNECTION DIAGRAM**

**DANGER: ELECTRICAL SHOCK HAZARD, DISCONNECT POWER BEFORE SERVICING.**

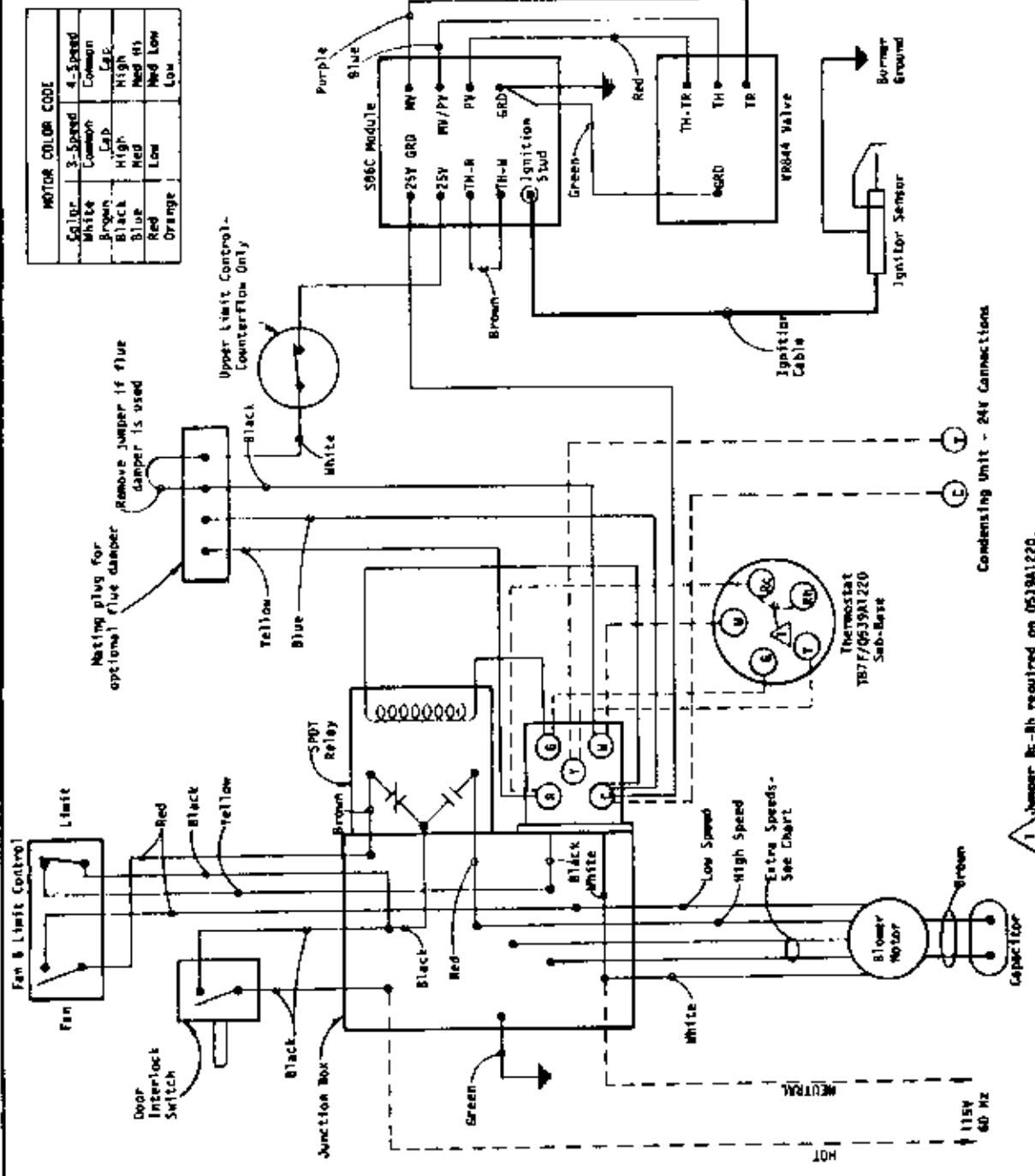

**LADDER DIAGRAM**

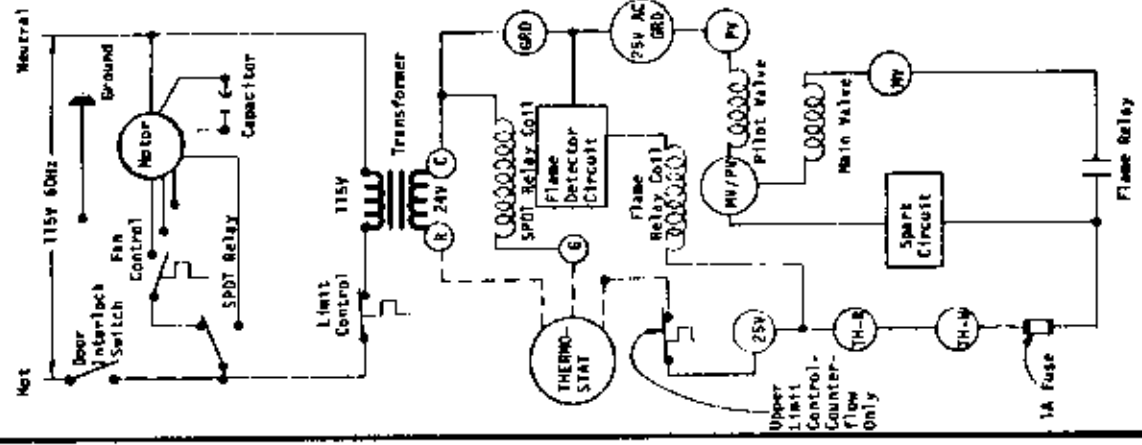

Factory Wiring  
Field Wiring

IF ANY OF THE ORIGINAL WIRING IS SUPPLIED WITH THE APPLIANCE, IT MUST BE REPLACED WITH WIRING MATERIAL HAVING A TEMPERATURE RATING AT LEAST 105°C.

3 & 4 SPEED MODELS, ELECTRIC IGNITION  
WIRING DIAGRAM 4046-103



PARTS LIST  
COUNTERFLOW GAS FURNACES

PART NO.	DESCRIPTION	CR1502	CR1502E	CR1502S	CR1502T	CR1502U	CR1502V	CR1502W	CR1502X	CR1502Y	CR1502Z
5153-012	Bearings 3/4"				X				X		X
5601-005	Belt 40"				X				X		X
5601-006	Belt 41"				X				X		X
5601-008	Belt 43"								X		X
8552-002	Capacitor 5/370V			X					X		X
5153-018	Collar 3/4"			X					X		X
5153-016	Cushion, Bearing			X					X		X
8402-001	FAN AND LIMIT 11"			X					X		X
7003-001	Filter 10x20 P			X					X		X
7003-003	Filter 15x20			X					X		X
9041-005	Heat Exchanger			X					X		X
9041-006	Heat Exchanger			X					X		X
9041-007	Heat Exchanger			X					X		X
*	Housing - Blower 10-7		X	X	X	X	X	X	X	X	X
*	Housing - Blower 10-9		X	X	X	X	X	X	X	X	X
*	Housing - Blower 12-10		X	X	X	X	X	X	X	X	X
8402-014	Limit Switch				X				X		X
5818-001	Manifold				X				X		X
5818-002	Manifold				X				X		X
5818-003	Manifold				X				X		X
8105-005	Motor 1/6 hp				X				X		X
8105-008	Motor 1/3 hp				X				X		X
8104-002	Motor 1/4 hp				X				X		X
8105-002	Motor 1/3 hp				X				X		X
8106-001	Motor 1/2 hp				X				X		X
5153-006	Motor Adj. Bracket				X				X		X
8200-016	Motor Mount				X				X		X
8200-013	Motor Mount				X				X		X
5481-011	Motor Mounting Parts				X				X		X
9010-010	Office - Mat				X				X		X
9010-009	Office - Mat				X				X		X
9010-004	Office - Mat				X				X		X
8584-002	Pilot Burner				X				X		X
8406-013	Micro Switch				X				X		X
5501-005	Pulley - Blower 6 x 3/4				X				X		X
5501-001	Pulley - Motor 3-1/4 x 1/2				X				X		X
5501-012	Pulley - Motor 6 x 3/4				X				X		X
5501-015	Pulley - Motor 3-1/4 x 1/2				X				X		X
1912-001	Shaft - Blower 15-1/4 x 3/4				X				X		X
1912-005	Shaft - Blower 16-1/2 x 3/4				X				X		X
8458-003	Thermocouple				X				X		X
8407-006	Transformer				X				X		X
8201-007	Transformer w/Relay				X				X		X
8201-006	Transformer w/2-Speed Relay				X				X		X
5651-032	Valve - Mat 1/2 x 3/4				X				X		X
9010-018	Venturi 2-Cell				X				X		X
9010-017	Venturi 3-Cell				X				X		X
9010-016	Venturi 4-Cell				X				X		X
5153-002	Wheel - Measure				X				X		X
5152-003	Wheel - Blower D09-6A				X				X		X
5152-014	Wheel - Blower D010-9A				X				X		X
5152-002	Wheel - Blower 10-9A				X				X		X
5152-022	Wheel - Blower 11-10				X				X		X

\*Please order by model number.

PARTS LIST  
ELECTRIC IGNITION  
COUNTERFLOW GAS FURNACES

PART NO.	DESCRIPTION	CR1502	CR1502E	CR1502S	CR1502T	CR1502U	CR1502V	CR1502W	CR1502X	CR1502Y	CR1502Z
5153-012	Bearings 3/4"				X				X		X
5601-005	Belt 40"				X				X		X
5601-006	Belt 41"				X				X		X
5601-008	Belt 43"								X		X
8552-002	Capacitor 5/370V			X					X		X
5153-018	Collar 3/4"			X					X		X
5153-014	Cushion, Bearing			X					X		X
8402-001	FAN AND LIMIT 11"			X					X		X
7003-001	Filter 10x20 P			X					X		X
7003-003	Filter 15x20 P			X					X		X
9041-005	Heat Exchanger			X					X		X
9041-006	Heat Exchanger			X					X		X
9041-007	Heat Exchanger			X					X		X
*	Housing - Blower 10-7		X	X	X	X	X	X	X	X	X
*	Housing - Blower 10-9		X	X	X	X	X	X	X	X	X
*	Housing - Blower 12-10		X	X	X	X	X	X	X	X	X
8600-001	Ignition Wire		X						X		X
8600-002	Ignition Wire		X						X		X
8600-003	Ignition Wire		X						X		X
8402-014	Limit Switch 140°				X				X		X
5818-001	Manifold MS2				X				X		X
5818-002	Manifold MS3				X				X		X
5818-003	Manifold MS4				X				X		X
8406-013	Micro Switch				X				X		X
8102-005	Motor 1/6 hp				X				X		X
8105-008	Motor 1/3 hp				X				X		X
8104-002	Motor 1/4 hp				X				X		X
8105-002	Motor 1/3 hp				X				X		X
8106-001	Motor 1/2 hp				X				X		X
8107-001	Motor 3/4 hp				X				X		X
5153-006	Motor Adj. Bracket				X				X		X
8200-016	Motor Mount				X				X		X
5451-011	Motor Mounting Parts				X				X		X
5651-024	Module - Mat				X				X		X
9010-010	Office - Mat				X				X		X
9010-009	Office - Mat				X				X		X
9010-004	Office - Mat				X				X		X
8584-002	Pilot and Grifice - Mat				X				X		X
5501-005	Pulley - Blower 6 x 3/4				X				X		X
5501-012	Pulley - Blower 3-1/4 x 1/2				X				X		X
5501-015	Pulley - Blower 6 x 3/4				X				X		X
5601-001	Pulley - Motor 3-1/4 x 1/2				X				X		X
5501-018	Pulley - Motor 4 x 5/8				X				X		X
1912-001	Shaft 15-1/4 x 3/4				X				X		X
1912-005	Shaft 16-1/2 x 3/4				X				X		X
8407-005	Terminal Block				X				X		X
8407-002	Transformer 20VA				X				X		X
8201-006	Fan Relay w/Trans.				X				X		X
5651-023	Valve - Mat 1/2 x 3/4				X				X		X
9010-018	Venturi 2-Cell				X				X		X
9010-016	Venturi 3-Cell				X				X		X
9010-017	Venturi 4-Cell				X				X		X
5152-003	Wheel D09-6A				X				X		X
5152-014	Wheel D010-9A				X				X		X
5152-002	Wheel A10-9A				X				X		X
5152-022	Wheel 11-10				X				X		X

\*Please order by model number.

PARTS LIST  
ELECTRIC IGNITION  
LO-BOY GAS FURNACES

Effective 1/1/80  
Supersedes 1/1/79

PART NO.	DESCRIPTION	G101C	G127E	G152E
5153-012	Bearings 3/4"	X	X	X
5601-005	Belt 40"	X	X	X
5601-001	Belt 36"	X	X	X
9010-014	Burner Venturi	X	X	X
9010-002	Burner Venturi	X	X	X
5153-018	Collar 3/4"	X	X	X
5153-014	Cushion - Bearing	X	X	X
1171-003	Door Handles	X	X	X
1171-002	Door Pull	X	X	X
8402-004	Fan and Limit 8"	X	X	X
8402-002	Fan and Limit 11"	X	X	X
7004-012	Fillter 20x20	X	X	X
7004-013	Fillter 20x25	X	X	X
7004-011	Fillter 16x25	X	X	(2)
5451-001	Grismet - Blower Leg	X	X	X
9041-001	Heat Exchanger	X	X	X
9041-002	Heat Exchanger	X	X	X
9041-003	Heat Exchanger	X	X	X
*	Housing - Blower 10-10	X	X	X
8406-005	Housing - Blower 12-10	X	X	X
8406-006	Ignition Wire	X	X	X
8406-013	Micro Switch	X	X	X
5651-024	Module 58501007	X	X	X
8102-001	Motor 1/6 hp	X	X	X
8104-002	Motor 1/4 hp	X	X	X
8105-002	Motor 1/2 hp	X	X	X
8200-014	Motor Adj. Kit	X	X	X
8200-015	Motor Mount	X	X	X
9010-005	Orifice Mat. #13 LP #24	X	X	X
8554-009	Pilot & Orifice Mat. #20 LP #14	X	X	X
5501-012	Pulley - Blower 6 x 3/4	X	X	X
5501-015	Pulley - Motor 3-1/4 x 1/2	X	X	X
8502-005	Shaft - Blower 15-1/4 x 3/4	X	X	X
8502-005	Terminal Block 0308001	X	X	X
8402-025	Thermostat	X	X	X
5651-005	Valve - Mat 1/2 x 3/4	X	X	X
5153-002	Washer - Neoprene	X	X	X
5152-008	Wheel - Blower 10-10	X	X	X
5152-022	Wheel - Blower 11-10	X	X	X

PARTS LIST  
LO-BOY GAS FURNACES

Effective 1/1/80  
Supersedes 1/1/79

PART NO.	DESCRIPTION	G101	G127	G152
5153-012	Bearings 3/4"	X	X	X
5601-005	Belt 40"	X	X	X
5601-001	Belt 36"	X	X	X
9010-014	Burner Venturi	X	X	X
9010-002	Burner Venturi	X	X	X
5153-018	Collar 3/4"	X	X	X
5153-014	Cushion - Bearing	X	X	X
1171-003	Door Handles	X	X	X
1171-002	Door Pull	X	X	X
8402-004	Fan and Limit 8"	X	X	X
8402-002	Fan and Limit 11"	X	X	X
7004-012	Fillter 20x20	X	X	X
7004-013	Fillter 20x25	X	X	X
7004-011	Fillter 16x25	X	X	(2)
5451-001	Grismet - Blower Leg	X	X	X
9041-001	Heat Exchanger	X	X	X
9041-002	Heat Exchanger	X	X	X
9041-003	Heat Exchanger	X	X	X
*	Housing - Blower 10-10	X	X	X
8406-013	Housing - Blower 12-10	X	X	X
8102-001	Motor 1/6 hp	X	X	X
8104-002	Motor 1/4 hp	X	X	X
8105-002	Motor 1/2 hp	X	X	X
8200-014	Motor Adj. Kit	X	X	X
8200-015	Motor Mount	X	X	X
9010-005	Orifice Mat. #13 LP #24	X	X	X
8554-002	Pilot Burner - Mat.	X	X	X
5501-012	Pulley - Blower 6 x 3/4	X	X	X
5501-015	Pulley - Motor 3-1/4 x 1/2	X	X	X
1912-001	Shaft - Blower 15-1/4 x 3/4	X	X	X
8502-004	Thermocouple	X	X	X
8402-005	Valve - Mat 1/2 x 3/4	X	X	X
5651-004	Washer - Neoprene	X	X	X
5153-002	Wheel - Blower 10-10	X	X	X
5152-005	Wheel - Blower 10-10	X	X	X
5152-022	Wheel - Blower 11-10	X	X	X

\*Please order by model number.