

INSTALLATION INSTRUCTIONS

BC48A AND BC60A

INDOOR BLOWER COIL UNIT

**FOR USE WITH
SPLIT HEAT PUMP AND
SPLIT AIR CONDITIONER SYSTEMS**

COPYRIGHT APRIL, 1989
BARD MANUFACTURING COMPANY
BRYAN, OHIO

INDEX

I.	Application and Location	7
	General	7
	Unpacking	7
	Application	7
	Ductwork	7
	Location and Clearances	8
	Mounting Positions	8
	Interconnecting Tubing	9
	Condensate Drain	9
II.	Wiring	10
	Thermostat Low-Voltage Wiring	10
	Transformer, Heat-Cool Blower Relay, Time Delay Relay (Optional), . .	10
	Fusing	
	Unit Operation	11
	Air Conditioning With or Without Supplemental Electric Heat	12
	Wire Diagrams	13
	Heat Pump With Supplemental Electric Heat	16
	Wire Diagrams	17
	Wall Thermostats	19
	How To Set An Adjustable Anticipator	20
	Additional Information For Electric Heat or Heat Pump Application . .	21
III.	Service	21
	Two Speed Blower Motor	21
	Blower Motor Oilers	21
	Filter	22
	Compressor Malfunction Relay	22
	Thermal Cut-Offs and Limit Control	22

INDEX OF FIGURES AND TABLES

Figure 1	1
Figure 2	8
Figure 3	20
Figure 4	21

Table 1	2
Table 2	3
Table 3	4
Table 4	5
Table 5	6
Table 6	10
Table 7	11
Table 8	12
Table 9	16
Table 10	19

BC48A AND BC60A SERIES
Built-In Electric Heating 5-30KW (230V)
Direct Drive Multispeed Motor (230V)
Slide-In Return Air Filter
Upflow-Downflow-Horizontal

FIGURE 1

**INDOOR SECTION
 UPFLOW POSITION**

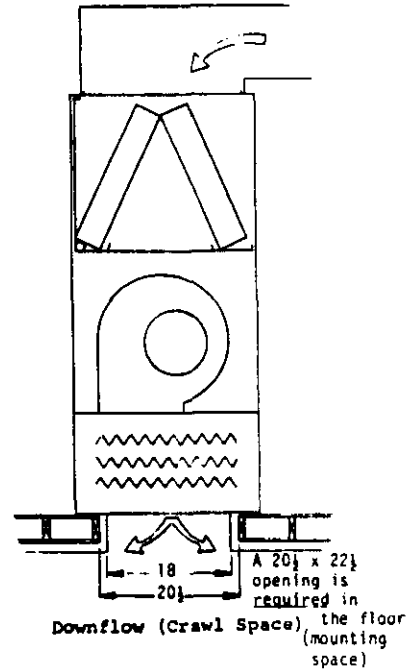
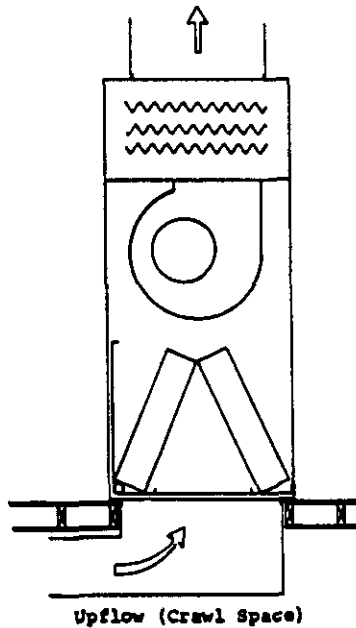
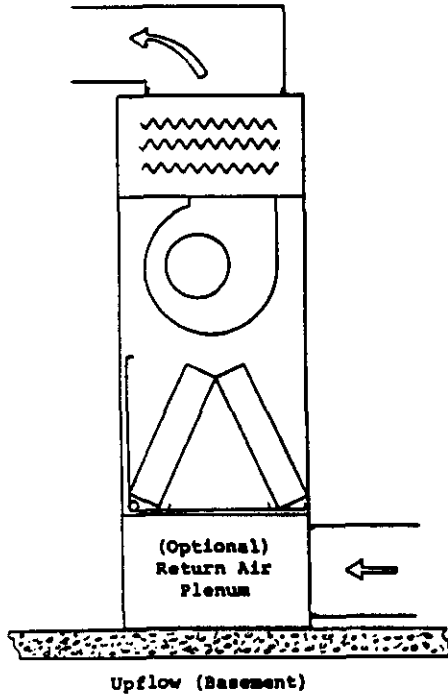
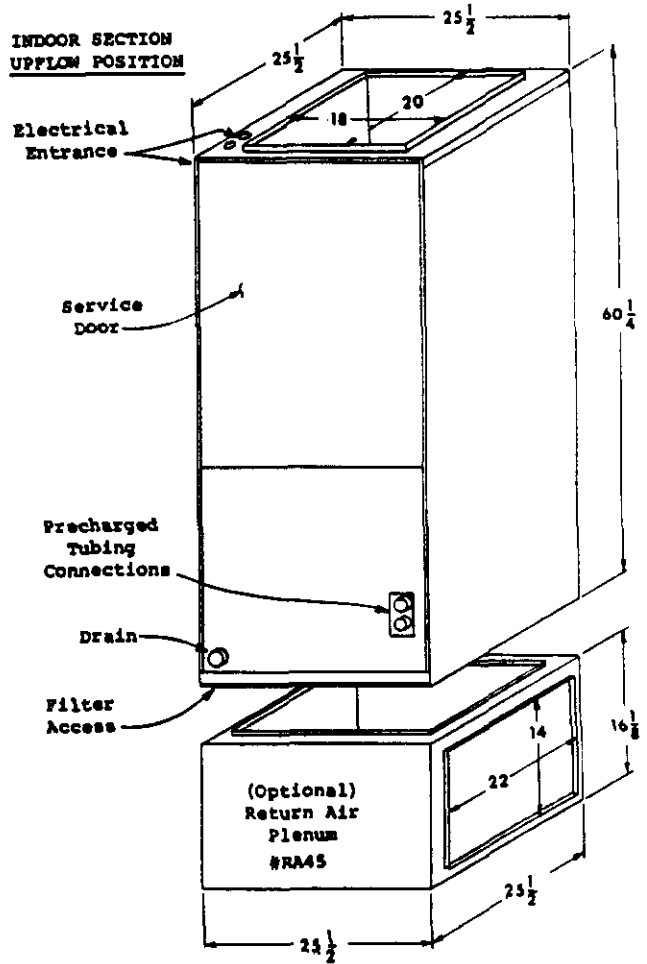
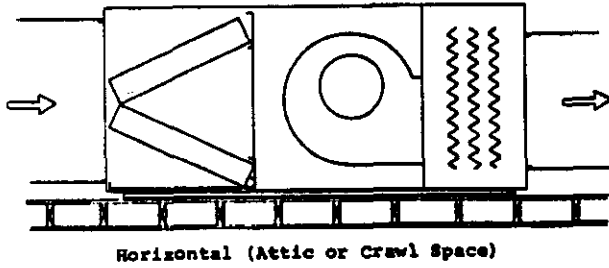

WARNING: Failure to provide the one inch clearance for the first two feet between the supply duct and a combustible surface can result in fire.

TABLE 1
 APPROVED MATCHED COMBINATIONS, RATED CFM, E.S.P.

Condensing Unit Model Number	Blower Coil Model Number	Rated Airflow 60 HZ		Blower Speed	Recommended Air Flow Range
		CFM	ESP		
42UACQA	BC48A	1525	.20	Low	1400 - 1675
	BC60A	1640	.40	Low	1515 - 1790
48UACQA	BC48A	1700	.30	High	1575 - 1850
	BC60A	1750	.30	Low	1625 - 1900
60UACQA	BC48A	1625	.40	High	1500 - 1775
	BC60A	1800	.20	High	1620 - 1980
42HPC4	BC48A	1540	.50	High	1415 - 1690
48HPC5	BC48A	1735	.45	High	1600 - 1875
	BC60A	1735	.35	High	1600 - 1875
60HPC5	BC60A	1800	.30	High	1620 - 1980
42ECQ1	BC48A	1575	.40	Low	1450 - 1725
48ECQ2	BC48A	1725	.30	Low	1600 - 1875
60ECQ1	BC48A	1625	.30	High	1500 - 1775
	BC60A	1800	.30	High	1620 - 1980

TABLE 2
ELECTRICAL RATINGS AND FACTORY INSTALLED ELECTRIC HEAT TABLE

Model	Volts/PH	Heater KW @ 240V	Max. Unit Amps	Heater Amps	Internal Fuses		Required Overcurrent Protection 4		Minimum Circuit Ampacity		Power Circuit Wiring ①		Ground Wire Size ②		
					Ckt. A	Ckt. B	Ckt. A	Ckt. B	Ckt. A	Ckt. B	Ckt. A	Ckt. B	Ckt. A	Ckt. B	
BC48A	240/208-1	0	4.4				15		15		14		14		
		10	46	41.6			60		58		4		10		
		15	66.9	62.5	60/30		90		84		2		8		
		20③	87.6	83.2	60/60		110		110		2		6		
		25	108.6	104.2	60	60/30	60	80	58	78	4	3	10	8	
		30	129.4	125.0	60	60/60	60	110	58	104	4	2	10	6	
	240/208-3	0	4.4					15		15		14		14	
		9	26.1	21.7				35		33		8		10	
		12	33.3	28.9				45		42		6		10	
		15	40.5	36.1				60		51		6		10	
		18③	47.6	43.2				60		60		4		10	
		21	54.9	50.5	35/40		70		69		4		8		
		24	62.2	57.8	45/40		80		78		3		8		
		27	69.4	65.0	45/45		90		87		2		8		
30	76.6	72.2	60/45		100		96		1		8				
BC60A	240/208-1	0	4.4				15		15		14		14		
		10	46	41.6			60		58		4		10		
		15⑤	66.9	62.5	60/30		90		84		2		8		
		20	87.6	83.2	60/60		110		110		2		6		
		25	108.6	104.2	60	60/30	60	80	58	78	4	3	10	8	
		30	129.4	125.0	60	60/60	60	110	58	104	4	2	10	6	
	240/208-3	0	4.4					15		15		14		14	
		9	26.1	21.7				35		33		8		10	
		12	33.3	28.9				45		42		6		10	
		15⑤	40.5	36.1				60		51		6		10	
		18	47.6	43.2				60		60		4		10	
		21	54.9	50.5	35/40		70		69		4		8		
		24	62.2	57.8	45/40		80		78		3		8		
		27	69.4	65.0	45/45		90		87		2		8		
30	76.6	72.2	60/45		100		96		1		8				

- ① Suggested size based on use of 60 degree C wiring material for ampacities less than 100A and 75 degree C wiring material for ampacities greater than 100A.
- ② Based upon Table 250-95 degree F 1981 N.E.C.
- ③ Maximum of 20KW 1 phase and 18KW 3 phase operates in conjunction with heat pump. Any installed KW above these amounts operates during emergency heat operation. See Tables 8 and 9 for additional information.
- ④ Time delay fuses or "BACR Type" circuit breakers must be used for 60 and smaller sizes. Standard fuses or circuit breakers are suitable for sizes 70 and larger.
- ⑤ Maximum of 15KW, 1 phase and 3 phase, operates in conjunction with heat pump. Any installed KW above this amount operates during emergency heat operation.

TABLE 3
 MAXIMUM E.S.P. OPERATION INFORMATION ① BC48A

Type Of Application	Upflow		Counterflow		Horizontal	
	Blower Speed		Blower Speed		Blower Speed	
	Low	High	Low	High	Low	High
Heat Pump w/30KW 1PH	②	②	②	②	②	②
Heat Pump w/25KW 1PH	②	②	②	②	②	②
Heat Pump w/20KW 1PH	.50	.60	.45	.55	.45	.55
Heat Pump w/15KW 1PH	.50	.60	.45	.55	.45	.55
Heat Pump w/10KW 1PH	.50	.60	.45	.55	.45	.55
Heat Pump w/30KW 3PH	②	②	②	②	②	②
Heat Pump w/27KW 3PH	②	②	②	②	②	②
Heat Pump w/24KW 3PH	②	②	②	②	②	②
Heat Pump w/21KW 3PH	②	②	②	②	②	②
Heat Pump w/18KW 3PH	.50	.60	.45	.55	.45	.55
Heat Pump w/15KW 3PH	.50	.60	.45	.55	.45	.55
Heat Pump w/12KW 3PH	.50	.60	.45	.55	.45	.55
Heat Pump w/9KW 3PH	.50	.60	.45	.55	.45	.55
30KW Only 1PH	.50	.60	.45	.55	.45	.55
25KW Only 1PH	.50	.60	.45	.55	.45	.55
20KW Only 1PH	.50	.60	.45	.55	.45	.55
15KW Only 1PH	.50	.60	.45	.55	.45	.55
10KW Only 1PH	.50	.60	.45	.55	.45	.55
30KW Only 3PH	.50	.60	.45	.55	.45	.55
27KW Only 3PH	.50	.60	.45	.55	.45	.55
24KW Only 3PH	.50	.60	.45	.55	.45	.55
21KW Only 3PH	.50	.60	.45	.55	.45	.55
18KW Only 3PH	.50	.60	.45	.55	.45	.55
15KW Only 3PH	.50	.60	.45	.55	.45	.55
12KW Only 3PH	.50	.60	.45	.55	.45	.55
9KW Only 3PH	.50	.60	.45	.55	.45	.55

① Values shown are for standard bottom return opening. Reduce the E.S.P. shown by .10 when using RA45 return air plenum.

② Not an approved application.

MAXIMUM E.S.P. OPERATION INFORMATION ① BC60A

Type Of Application	Upflow Blower Speed		Counterflow Blower Speed		Horizontal Blower Speed	
	Low	High	Low	High	Low	High
Heat Pump w/30KW 1PH	②	②	②	②	②	②
Heat Pump w/25KW 1PH	②	②	②	②	②	②
Heat Pump w/20KW 1PH	②	②	②	②	②	②
Heat Pump w/15KW 1PH	.50	.60	.45	.55	.45	.55
Heat Pump w/10KW 1PH	.50	.60	.45	.55	.45	.55
Heat Pump w/30KW 3PH	②	②	②	②	②	②
Heat Pump w/27KW 3PH	②	②	②	②	②	②
Heat Pump w/24KW 3PH	②	②	②	②	②	②
Heat Pump w/21KW 3PH	②	②	②	②	②	②
Heat Pump w/18KW 3PH	.50	.60	.45	.55	.45	.55
Heat Pump w/15KW 3PH	.50	.60	.45	.55	.45	.55
Heat Pump w/12KW 3PH	.50	.60	.45	.55	.45	.55
Heat Pump w/9KW 3PH	.50	.60	.45	.55	.45	.55
30KW Only 1PH	.50	.60	.45	.55	.45	.55
25KW Only 1PH	.50	.60	.45	.55	.45	.55
20KW Only 1PH	.50	.60	.45	.55	.45	.55
15KW Only 1PH	.50	.60	.45	.55	.45	.55
10KW Only 1PH	.50	.60	.45	.55	.45	.55
30KW Only 3PH	.50	.60	.45	.55	.45	.55
27KW Only 3PH	.50	.60	.45	.55	.45	.55
24KW Only 3PH	.50	.60	.45	.55	.45	.55
21KW Only 3PH	.50	.60	.45	.55	.45	.55
18KW Only 3PH	.50	.60	.45	.55	.45	.55
15KW Only 3PH	.50	.60	.45	.55	.45	.55
12KW Only 3PH	.50	.60	.45	.55	.45	.55
9KW Only 3PH	.50	.60	.45	.55	.45	.55

① Values shown are for standard bottom return opening. Reduce the E.S.P. shown by .10 when using RA45 return air plenum.

② Not an approved application.

TABLE 5
 INDOOR BLOWER COIL PERFORMANCE (DRY COIL @ 230 VOLT 60 HZ ②) ①

Model	KW	Speed	Position	IN H ₂ O						
				.00	.10	.20	.30	.40	.50	.60
BC48A	0	Hi	All	2040	1965	1885	1810	1715	1615	1520
BC48A	0	Low	All	1825	1775	1725	1670	1585	1500	1420
BC48A	10	Hi	All	2010	1935	1855	1780	1685	1585	1490
BC48A	10	Low	All	1795	1745	1695	1640	1555	1470	--
BC48A	20	Hi	All	1980	1905	1825	1750	1655	1555	1460
BC48A	20	Low	All	1765	1715	1665	1610	1525	1440	--
BC48A	30	Hi	All	1950	1875	1795	1720	1625	1525	1430
BC48A	30	Low	All	1735	1685	1635	1580	1495	1410	--
BC60A	0	Hi	All	2050	2010	1950	1875	1800	1715	1620
BC60A	0	Low	All	1830	1810	1785	1715	1660	1590	--
BC60A	10	Hi	All	2020	1980	1920	1845	1770	1685	1590
BC60A	10	Low	All	1800	1780	1755	1685	1630	1560	--
BC60A	20	Hi	All	1990	1950	1890	1815	1740	1655	1560
BC60A	20	Low	All	1770	1750	1725	1655	1600	1530	--
BC60A	30	Hi	All	1960	1920	1860	1785	1710	1625	1530
BC60A	30	Low	All	1740	1720	1695	1625	1570	1500	--

① Values shown are standard for both bottom return. Add .10 ESP when using RA45 return air plenum.

② Reduce airflow values shown by 190 CFM for 208 volt operation.

I. APPLICATION AND LOCATION

GENERAL

Units are shipped completely assembled and internally wired requiring only duct connections, thermostat wiring, and external 208-240 volt AC power supply.

The BC48A and BC60A blower coil units with various KW electric heat options, are suitable for use with the following air conditioner and heat pump outdoor sections. It can be used both as an air conditioning system with electric heat and as a heat pump with electric heat. Refer to sections titled, "Air Conditioning With Electric Heat" and "Heat Pump With Electric Heat" for complete information.

UNPACKING

Upon receipt of equipment, carton should be checked for external signs of damage. If damage is found, request for inspection by carrier's agent should be made in writing immediately.

APPLICATION

Size of unit for a proposed installation should be based on heat loss calculation made according to methods of Air Conditioning Contractors of America. The air duct should be installed in accordance with the Standards of the National Fire Protection Association for the Installation of Air Conditioning and Ventilating Systems of Other Than Residence Type, NFPA No. 90A, and Residence Type Warm Air Heating and Air Conditioning System, NFPA No. 90B. Where local regulations are at a variance with instructions, installer should adhere to local codes.

DUCTWORK

Design the ductwork according to methods given by the Air Conditioning Contractors of America. When duct runs through unheated spaces, it should be insulated with a minimum of two inches of insulation. Use insulation with a vapor barrier on the outside of the insulation. Flexible joints should be used to connect the ductwork to the equipment in order to keep the noise transmission to a minimum.

LOCATION AND CLEARANCES

All access to the equipment is from one side, and at least 24 inches should be provided from this side for service access.

Unit casing is suitable for 0 inch clearance. The first four (4) feet of ductwork attached to the outlet (supply air) connections of the unit are to have a minimum of one inch clearance, with 0 inch clearance for any remaining ductwork.

A CFB45 combustible floor base is required for downflow installations to assure a 1" clearance from combustible materials to the outlet plenum (duct).

A 20-1/2 x 22-1/2 opening is required in the floor (mounting surface). See illustration.

The CFB45 combustible floor base must be ordered separately. It is not included as part of the basic unit.

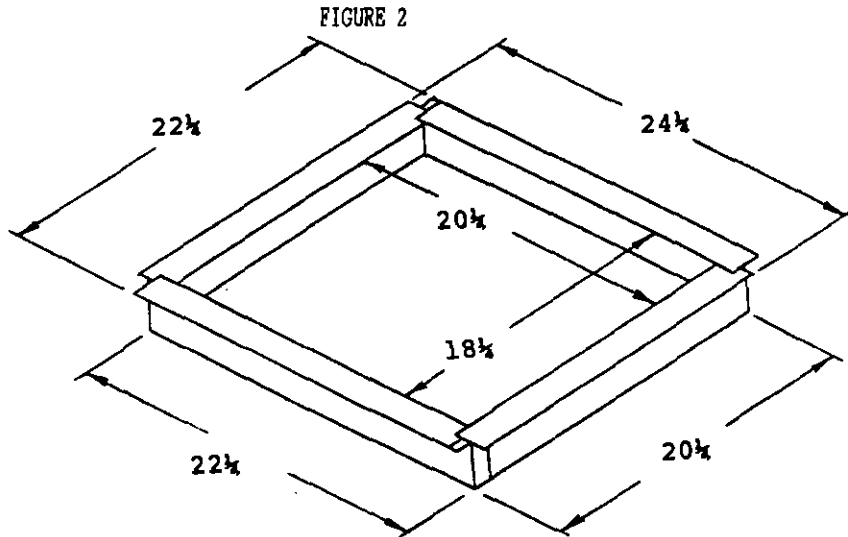

WARNING: Failure to provide the one inch clearance for the first two feet between the supply duct and a combustible surface can result in fire.

MOUNTING POSITIONS

The BC48A and BC60A can be installed in three positions with respect to airflow direction: upflow, horizontal and downflow. The general intent of these mounting positions is shown on Page 1 of this installation manual. Capacity and efficiency ratings are certified in the vertical installation position. Capacity may be reduced slightly for other installation positions.

Return air plenum RA45 is required for upflow installations (unless a crawl space or similar installation with return air duct beneath unit mounting surface). The RA45 plenum is square in design and the 14" x 22" duct flange can be positioned as desired for ease of installation.

The unit is shipped with the coil installed for upflow mounting position. It is secured in place by four screws, one at each bottom front corner of the slide support angles and one on the front and rear of the top left slide support. To convert to either horizontal or downflow position, remove front access panel, remove the four screws securing coil pan assembly, and remove coil.

Place cabinet in desired mounting position and reinstall coil as shown on Page 1. Make sure the coil is installed as shown with respect to blower. It is not necessary to reinstall shipping bracket or the two securing screws through the slide angles.

IMPORTANT: The unit as received has coil installed for upflow position only. It must be rotated 180 degrees for horizontal and downflow positions. See note under "Condensate Drain."

INTERCONNECTING TUBING

It is recommended that the interconnecting tubing be the CT-12 series charged tubing sets. This is a precharged tubing set with an insulated suction line. Both suction and liquid line are equipped with the correct quick connect fittings for proper match-up to the indoor and outdoor sections. The CT-12 series is available in standard tubing lengths of 15, 25, 35 and 45 feet.

NOTE: Applicable installation codes may limit installation to single story structures only if return air duct is not used.

CONDENSATE DRAIN

Determine where the drain line will run. This drain line contains cold water and must be insulated to avoid drops of water from dropping on ceiling, etc. A trap must be installed in the primary drain line below the bottom of the drain pan.

For horizontal installations with auxiliary drain pan, a separate drain line should be run from the auxiliary drain pan and terminated where the homeowner can see it. Be certain to show the homeowner the location of the drain line and to explain its purpose. In the event of overflow of primary drain, water will collect in auxiliary pan and run out through the auxiliary drain line.

It is not recommended that any condensate drain lines be connected to a sewer main. Drain lines must be installed in accordance with local codes.

When installed horizontal in an attic installation, a platform should be made for the unit to sit on. This platform can be made from 3/4" plywood or boards. An auxiliary drain pan should always be used when equipment is installed over a finished living area to provide protection from water damage in case of plugging of the primary drain line from the unit condensate collection pan.

Secure 4 pieces of cork or live rubber, 4" x 4", of sufficient thickness to allow primary drain to clear edge of auxiliary drain pan, under each corner of the unit.

NOTE: There is a 3/8" copper tube brazed on an angle through the coil drain pan approximately 2" from the 3/4" main drain pipe coupling. This is an overflow drain to control the point at which water would exit the drain pan in the event the primary drain becomes plugged. When the coil assembly is removed and reinstalled for downflow, make sure the 3/8" drain overflow tube extends slightly beyond the coil door when in place.

II WIRING

THERMOSTAT LOW-VOLTAGE WIRING

A 24V terminal block is mounted on the inside of the unit. There is also a 24V terminal block located in the outdoor section of remote heat pumps and two tagged 24V wires in the outdoor section of remote air conditioners. Wire sizing is determined from the table below for 24V control circuit wiring.

<u>Transformer VA</u>	<u>FLA @ 240V</u>	<u>Maximum Distance in Feet</u> ①
65	2.7	20 gauge - 40 18 gauge - 55 16 gauge - 85 14 gauge - 135 12 gauge - 210

① For split systems, this is the maximum distance between the indoor section and outdoor section, and between the indoor section and thermostat each could be up to 90 feet for 18 gauge and 65 feet for 20 gauge on 40VA transformer. With a 65VA transformer and 20 gauge wire, the maximum distance is 40 feet. For single package equipment, this is the distance between the unit and the thermostat.

Specific control circuit wiring diagrams for the various applications are referenced in the sections titled "Air Conditioning With Electric Heat" and "Heat Pump With Electric Heat". These diagrams detail the recommended controls and wiring to allow the best possible operation of the different types of systems with respect to energy conservation while still maintaining close comfort levels for the occupant.

TRANSFORMER, HEAT-COOL BLOWER RELAY, TIME DELAY RELAY (OPTIONAL), FUSING

The BC48A and BC60A are provided with a 65VA transformer. The transformer is protected by a 3 amp fuse located in the 24V terminal block compartment and wired into the transformer secondary.

A heat-cool blower relay is installed to provide blower operation automatically with any thermostat demand for heating or cooling, or can be operated continuously for air circulation on command from the thermostat fan switch.

An optional time delay relay may be installed in the cooling low voltage circuit. This relay permits the blower motor to continue to operate for approximately one minute following each cooling cycle.

All single phase models with 15KW or higher and all three phase models with 18KW or higher are internally fused and subdivided. See electrical data tables for more information.

UNIT OPERATION

The controls in the BC48A and BC60A provide for manual/auto fan blower operation in addition to the staging of the installed electric heat. The table below lists the stages by KW breakdown for both air conditioning and heat pump installations.

IMPORTANT NOTE: With model BC48A, a maximum of 20KW 1 phase and 18kw 3phase can be operated in conjunction with a heat pump. If using model BC60A, the maximum amount of electric heat, single and three phase to be used in conjunction with a heat pump, is 15KW. Larger KW's can be installed as shown below, but will function only during defrost cycle, emergency heat operation, or periods of compressor cut-off if used.

TABLE 7
CONTROL STAGES BY HEATER KW

Model	Total KW	PH	Matched With A/C			Matched with Heat Pump			
			Wall Thermostat		Outdoor Thermostat	Wall Thermostat		Outdoor Thermostat	Emergency Heat
			1st Stage	2nd Stage		1st Stage	2nd Stage		
BC48A	10	1	10	--		HP ①	10 ⑤		
	15	1	10	5		HP	15 ⑤⑧	⑧	
	20	1	10	10		HP	20 ③⑤	③	
	25	1	10	10	5 ②	HP	20 ③⑤	③	5
	30	1	10	10	10 ②	HP	20 ③⑤		10
	9	3	9	--		HP	9 ⑤		
	12	3	12	--		HP	12 ⑤		
	15	3	15	--		HP	15 ⑤		
	18	3	9	9		HP	9 ④		9
	21	3	9	12		HP	9 ④		12
	24	3	12	12		HP	12 ④		12
	27	3	12	15		HP	12 ④		15
	30	3	15	15		HP	15 ④		15
	BC60A	10	1	10	--		HP ①	10 ⑤	
15		1	10	5		HP	15 ⑤⑧	⑧	
20		1	10	10		HP	15 ⑤⑧	⑧	
25		1	10	10	5 ②	HP	15 ⑤⑧	⑧	5
30		1	10	10	10 ②	HP	15 ⑤		10
9		3	9	--		HP	9 ⑤		
12		3	12	--		HP	12 ⑤		
15		3	15	--		HP	15 ⑤		
18		3	9	9		HP	9 ④		9
21		3	9	12		HP	9 ④		12
24		3	12	12		HP	12 ④		12
27		3	12	15		HP	12 ④		15
30		3	15	15		HP	15 ④		15

- ① Heat pump is always in 1st stage.
- ② If outdoor thermostat is not used, 24V terminals DH and O1 must be connected together. The KW shown under outdoor thermostat will then cycle with 2nd stage.
- ③ If one outdoor thermostat is used, 10KW will switch from 2nd stage to outdoor thermostat, leaving only 10KW on 2nd stage. This is normally recommended.
- ④ This amount of heat also cycles on during brief defrost cycles.
- ⑤ If 2nd stage wall thermostat is not calling for heat, this amount of KW will automatically come on during defrost cycles.
- ⑥ If 2nd stage wall thermostat is not calling for heat, 5KW will automatically come on during defrost.
- ⑦ To operate all 18KW with HP, use one outdoor thermostat.
- ⑧ If one outdoor thermostat is used, 5KW will switch from 2nd stage to outdoor thermostat, leaving only 10KW on 2nd stage.

AIR CONDITIONING WITH OR WITHOUT SUPPLEMENTAL ELECTRIC HEAT

When the BC48A or BC60A are matched with the approved outdoor air conditioning sections, different thermostats may be required depending on installed KW and desired staging. Listed below are the "recommended" wall thermostats, subbases, number of outdoor thermostats, and number of 24V wires required, and connection diagrams.

TABLE 8

Model	KW	PH	Part No.	Description	Part No.	Description	No. of ^① Outdoor Thermostats	Number of 24V Wires Required		Connection Diagram	
								Thermostat To I.D. Unit	I.D. Unit To O.D. Unit		
BC48A	0	1	8403-002	T87F3111	8404-003	Q539A1220		3	2	4091-300	
	10	1	8403-002	T87F3111	8404-003	Q539A1220		4	2	4091-301	
	15	1	8403-019	T874C1000	8404-012	Q674A1001		5	2	4091-303	
	20	1	8403-019	T874C1000	8404-012	Q674A1001		5	2	4091-303	
	25	1	8403-019	T874C1000	8404-012	Q674A1001	1	5	4	4091-304	
	30	1	8403-019	T874C1000	8404-012	Q674A1001	1	5	4	4091-304	
	0	3	8403-002	T87F3111	8404-003	Q539A1220		3	2	4091-300	
	9	3	8403-002	T87F3111	8404-003	Q539A1220		4	2	4091-301	
	12	3	8403-002	T87F3111	8404-003	Q539A1220		4	2	4091-301	
	15	3	8403-002	T87F3111	8404-003	Q539A1220		4	2	4091-301	
	18	3	8403-019	T874C1000	8404-012	Q674A1001		5	2	4091-303	
	21	3	8403-019	T874C1000	8404-012	Q674A1001		5	2	4091-303	
	24	3	8403-019	T874C1000	8404-012	Q674A1001		5	2	4091-303	
	27	3	8403-019	T874C1000	8404-012	Q674A1001		5	2	4091-303	
	30	3	8403-019	T874C1000	8404-012	Q674A1001		5	2	4091-303	
	BC60A	0	1	8403-002	T87F3111	8404-003	Q539A1220		3	2	4091-300
		10	1	8403-002	T87F3111	8404-003	Q539A1220		4	2	4091-301
		15	1	8403-019	T874C1000	8404-012	Q674A1001		5	2	4091-303
20		1	8403-019	T874C1000	8404-012	Q674A1001	1	5	4	4091-305	
25		1	8403-019	T874C1000	8404-012	Q674A1001	1	5	4	4091-305	
30		1	8403-019	T874C1000	8404-012	Q674A1001	1	5	4	4091-305	
0		3	8403-002	T87F3111	8404-003	Q539A1220		3	2	4091-300	
9		3	8403-002	T87F3111	8404-003	Q539A1220		4	2	4091-301	
12		3	8403-002	T87F3111	8404-003	Q539A1220		4	2	4091-301	
15		3	8403-002	T87F3111	8404-003	Q539A1220		4	2	4091-301	
18		3	8403-019	T874C1000	8404-012	Q674A1001		5	2	4091-303	
21		3	8403-019	T874C1000	8404-012	Q674A1001		5	2	4091-303	
24		3	8403-019	T874C1000	8404-012	Q674A1001		5	2	4091-303	
27		3	8403-019	T874C1000	8404-012	Q674A1001		5	2	4091-303	
30		3	8403-019	T874C1000	8404-012	Q674A1001		5	2	4091-303	

① ODT-070 adjustable range 0 to 70 degree F. These are field installed in outdoor sections.

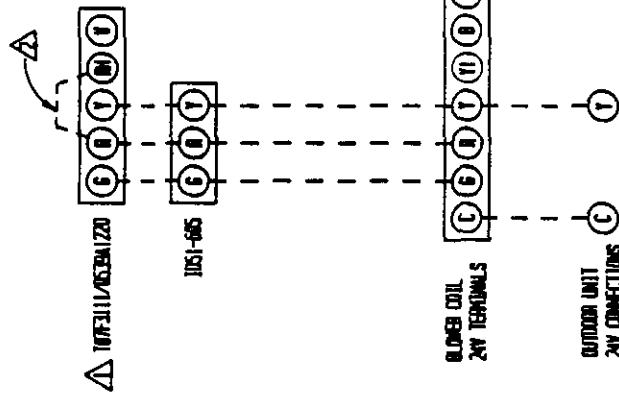

△ 167F311/653B/1228

1151-665

BLOWER COIL
24V TERMINALS

OUTDOOR UNIT
24V CONNECTIONS

- △ SET ADJUST HEAT ANTICIPATOR (SEE BLOWER COIL INSTRUCTIONS).
- △ INSTALL JUMPER R-RH

AIR CONDITIONER W/ORN BLOWER COIL

LOW VOLTAGE	FACTORY WIRING	FIELD WIRING
HIGH VOLTAGE	FACTORY WIRING	FIELD WIRING

4091-300

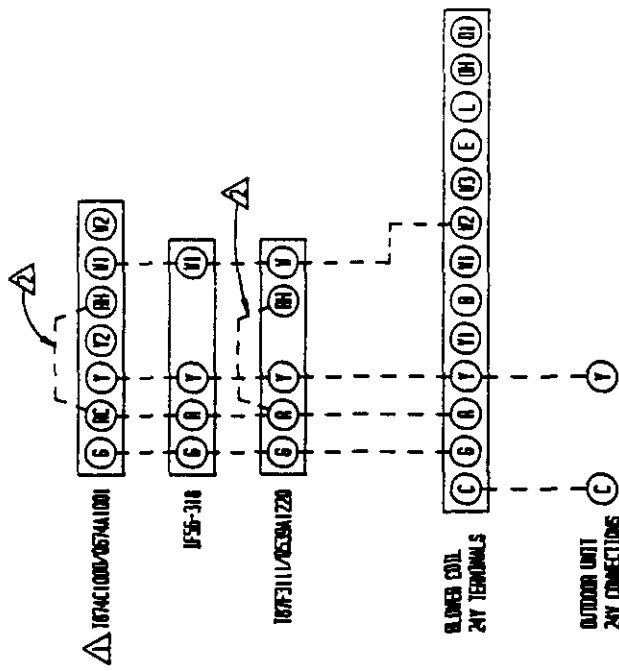

△ 167F311/653B/1228

1F55-316

167F311/653B/1228

BLOWER COIL
24V TERMINALS

OUTDOOR UNIT
24V CONNECTIONS

- △ SET ADJUST HEAT ANTICIPATOR (SEE BLOWER COIL INSTRUCTIONS).
- △ INSTALL JUMPER R-RH OR R-RH

AIR CONDITIONER W/VS TO YORK BLOWER COIL EXCEPT FOR R-RH/A10

LOW VOLTAGE	FACTORY WIRING	FIELD WIRING
HIGH VOLTAGE	FACTORY WIRING	FIELD WIRING

4091-301

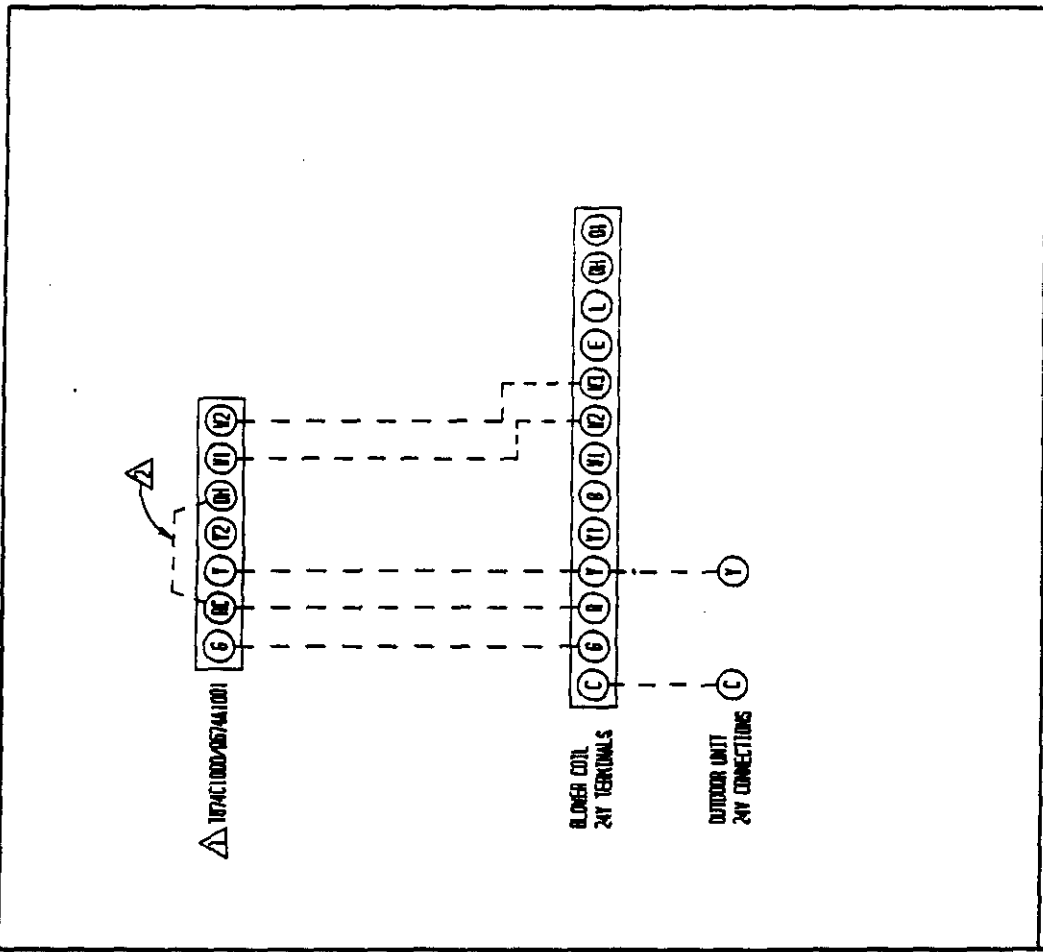

- △ SET ADJUST HEAT ANTICIPATOR (SEE BLOWER COIL INSTRUCTIONS).
- △ INSTALL JUMPER RC-RH

AIR CONDITIONER 1/4 TO 200V BLOWER COIL EXCEPT FOR RC-RH-A15 & RC-RH-A16

FACTORY WIRING	FIELD WIRING
LOW VOLTAGE	---
HIGH VOLTAGE	---

4891-303

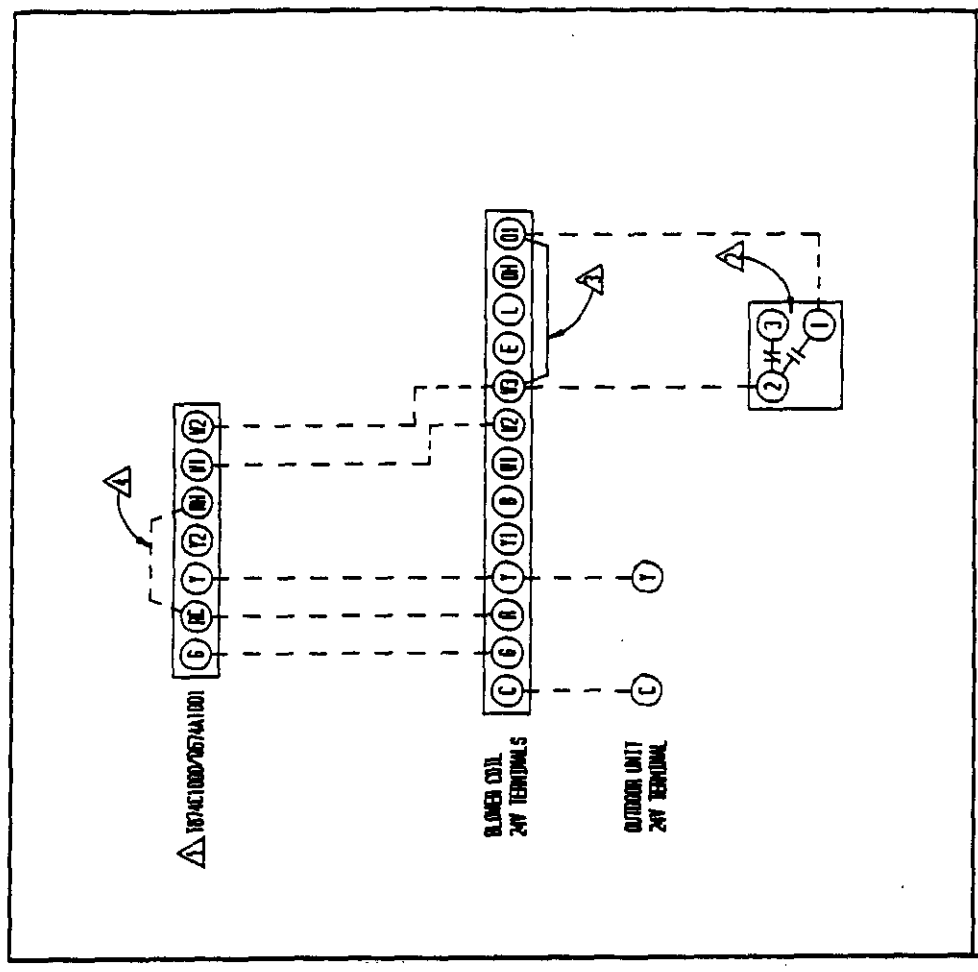

AIR CONDITIONER 1/4 TO 300V BLOWER COIL EXCEPT RC-RH MODELS

- △ SET ADJUST HEAT ANTICIPATOR (SEE BLOWER COIL INSTRUCTIONS).
- △ WHEN OUTDOOR THERMOSTAT IS USED TO HOLD LAST 5.0, OR 150W OF HEAT, FROM CYCLING WITH THE NORMAL 100W ON 2ND STAGE. LOCATE IN OUTDOOR UNIT.
- △ WHEN OUTDOOR THERMOSTAT IS USED, REMOVE JUMPER RC-RH.
- △ INSTALL JUMPER RC-RH.

FACTORY WIRING	FIELD WIRING
LOW VOLTAGE	---
HIGH VOLTAGE	---

4891-304

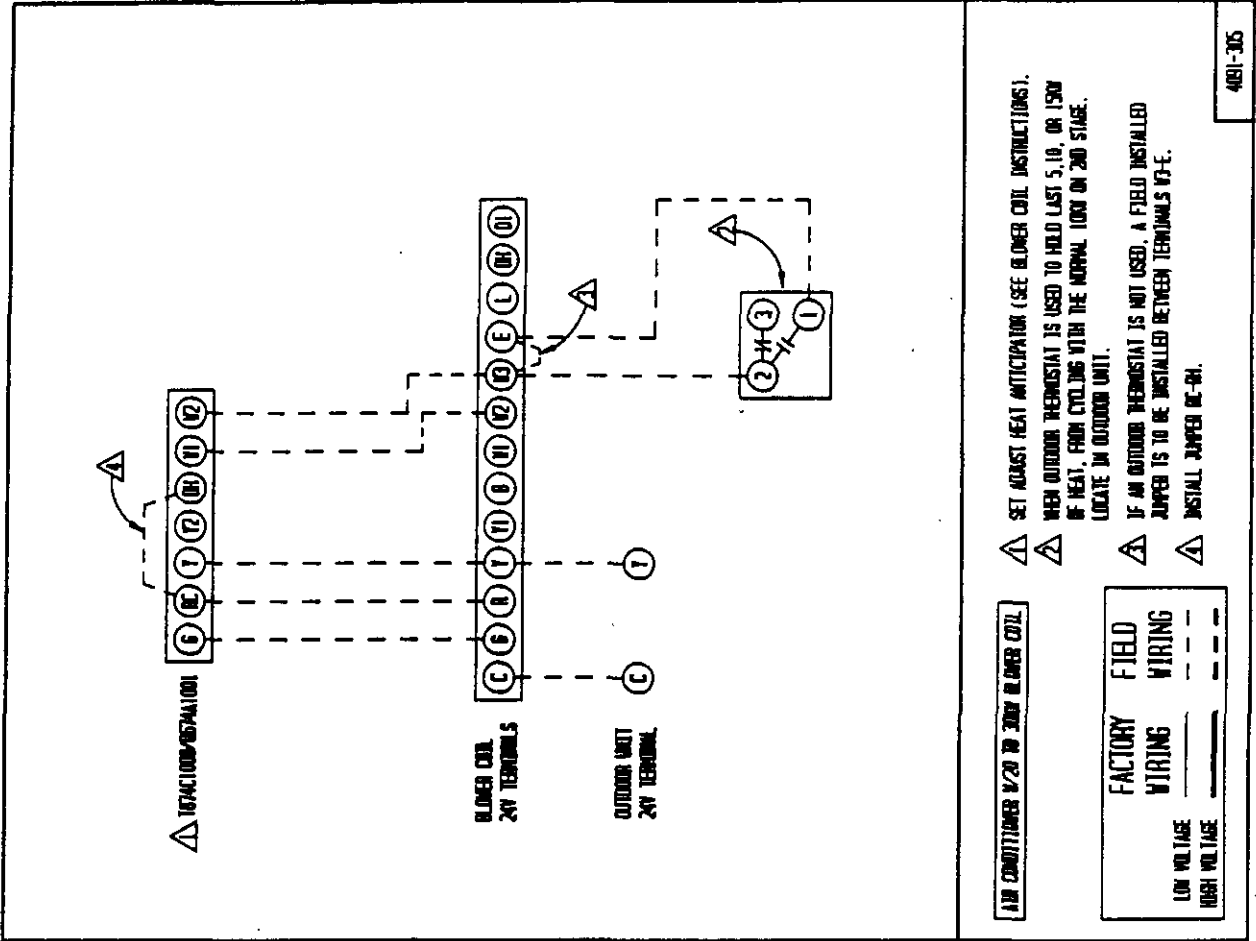

HEAT PUMP WITH SUPPLEMENTAL ELECTRIC HEAT

The system and its safety controls are designed in such a manner that the heat pump and a maximum of 20KW 1 phase and 18kw 3 phase (15KW, 1 and 3 phase for model BC60A) can operate simultaneously. Larger KW's can be installed, however, and are controlled by the emergency heat switch and/or field installed compressor cut-off. This allows for "total" heating capability in case of a malfunction in the outdoor heat pump unit.

Listed below are the thermostats required for use with these heat pump models. It is essential that one or the other of these thermostat and subbase combinations be used because the internal wiring of both the heat pump unit and the thermostat are specifically designed for one another.

TABLE 9

Model	KW	PH	Wall Thermostat		Subbase Combinations		Number of ① Outdoor ② Thermostats	Number of 24V Wires Required		Connection Diagram
			Part No.	Description	Part No.	Description		Thermostat To I.D. Unit	I.D. Unit To O.D. Unit	
BC48A	0	1						8	6	4091-400
	10	1					1 ③	9	7	4091-402
	15	1					2 ③	10	9	4091-404
	20	1					2 ④	10	9	4091-404
	25	1					2 ③	10	9	4091-404
	30	1					2 ③	10	9	4091-404
	0	3						8	6	4091-400
	9	3					1	9	7	4091-402
	12	3					1	9	7	4091-402
	15	3					1	9	7	4091-402
	18	3					1 ③	10	9	4091-404
	21	3	8403-017	T874R1129	8404-009	Q674L1181	1	9	7	4091-402
	24	3					1	9	7	4091-402
	27	3					1	9	7	4091-402
	30	3		OR			1	9	7	4091-402
BC60A	0	1						8	6	4091-400
	10	1					1 ③	9	7	4091-402
	15	1					2 ③	10	9	4091-404
	20	1	8403-019	T874N1024	8404-010	Q674F1261	2 ④	10	9	4091-404
	27	1					2 ③	10	9	4091-404
	30	1					1 ③	9	7	4091-402
	0	3						5	5	4091-400
	9	3					1	9	7	4091-402
	12	3					1	9	7	4091-402
	15	3					1	9	7	4091-402
	18	3					2	10	9	4091-404
	21	3					1	9	7	4091-402
	24	3					1	9	7	4091-402
	27	3					1	9	7	4091-402
	30	3					1	9	7	4091-402

① ODT-070 adjustable range 0 to 70 degree F. These are field installed in outdoor sections.

② Compressor cutoff recommended for all climate areas that experience subzero temperatures.

③ The last 5, 10, and 9KW for 15, 20, 25, and 18KW models can be held off by using one (1) outdoor thermostat. This is optional.

④ One outdoor thermostat should be used to keep first 20kw from cycling together on stage 2 of wall thermostat. The 5, 10, or 15KW cycles on only during emergency heat, compressor cutoff, or defrost cycle.

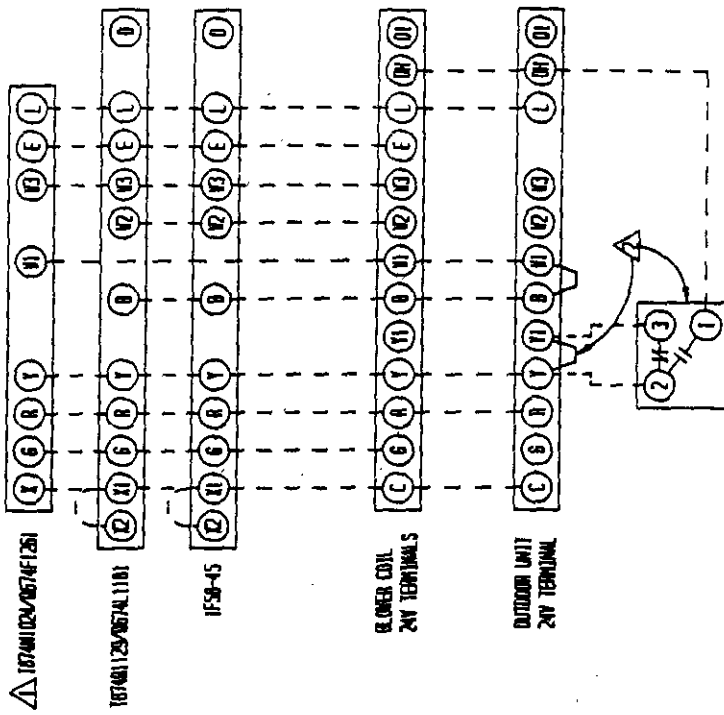

- △ SET ADJUST HEAT ANTICIPATOR (SEE BLOWER COIL INSTRUCTIONS).
- △ WHEN OUTDOOR THERMOSTAT (USED AS COMPRESSOR DUTY) IS INSTALLED, REMOVE JUMPER Y-T.

HEATPUMP V/10 TO 120V BLOWER COIL

	FACTORY WIRING	FIELD WIRING
LOW VOLTAGE	---	---
HIGH VOLTAGE	---	---

4891-402

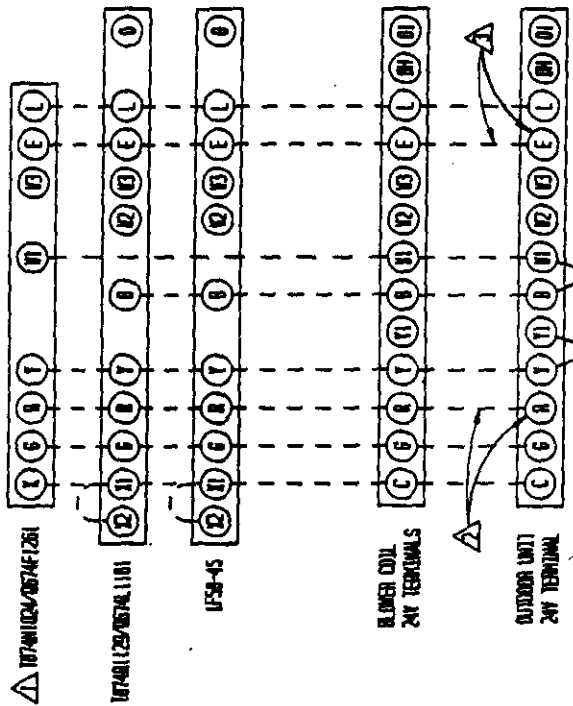

- △ SET ADJUST HEAT ANTICIPATOR (SEE BLOWER COIL INSTRUCTIONS).
- △ 18-28HP UNITS DO NOT HAVE ① TERMINAL AND IT IS NOT REQUIRED TO RUN AN ① WIRE TO THESE MODELS.
- △ 42-50HP UNITS DO NOT HAVE ② TERMINAL AND IT IS NOT REQUIRED TO RUN AN ② WIRE TO THESE MODELS.

HEATPUMP V/100 BLOWER COIL

	FACTORY WIRING	FIELD WIRING
LOW VOLTAGE	---	---
HIGH VOLTAGE	---	---

4891-400

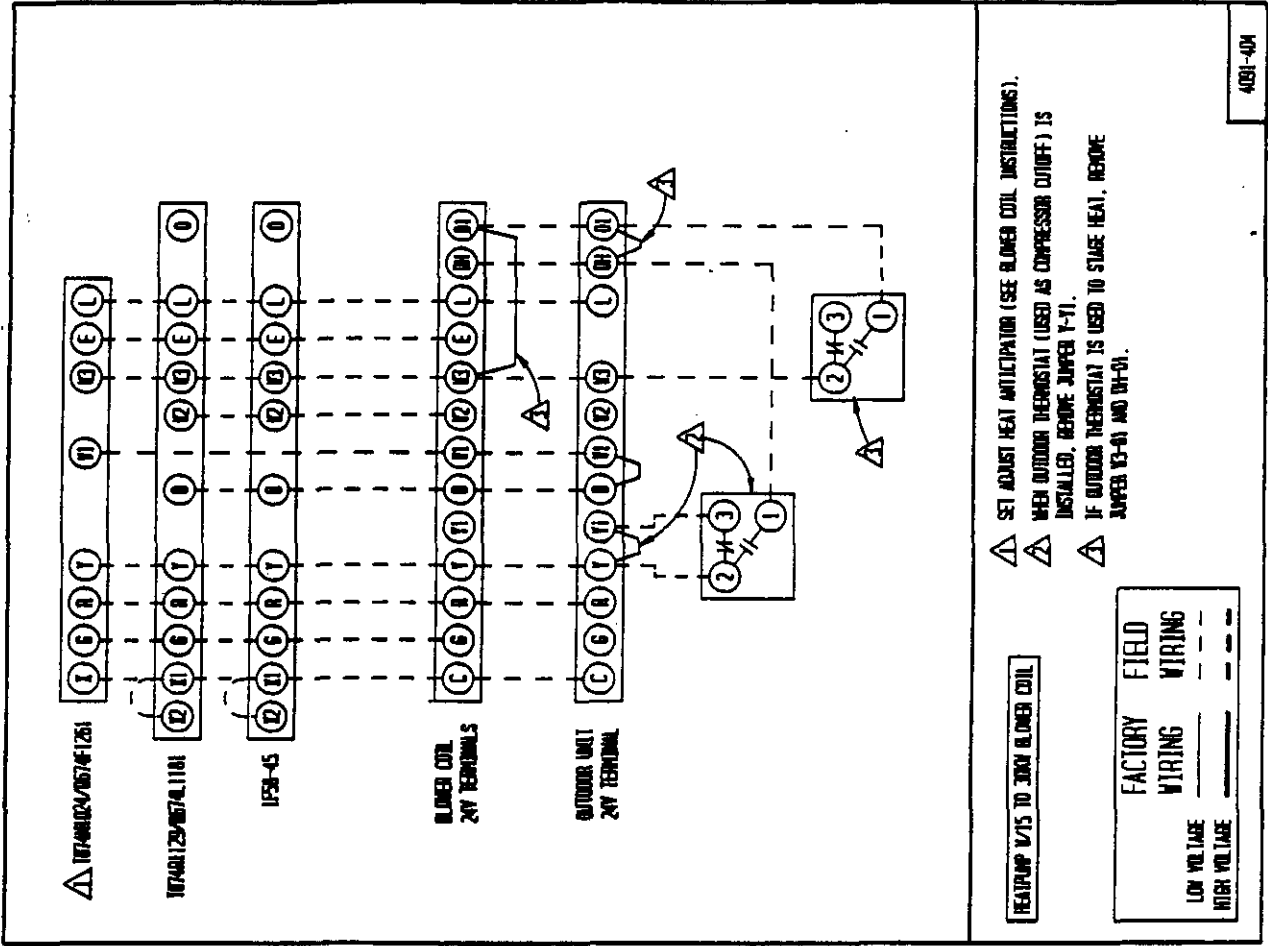

WALL THERMOSTATS

The following wall thermostats and subbases should be used as indicated, depending on the application.

TABLE 10

AIR CONDITIONING THERMOSTATS		
Part No.	Model No.	Description
8403-002	T87F3111	THERMOSTAT--1 stg. heat, adj. heater, Mercury
8404-003	Q539A1220	SUBBASE --System Heat-Off-Cool Fan: On-Auto
8403-008	ID51-605	THERMOSTAT--1 stg. cool, System w/Off Sw. Snap Action Fan: Auto-On
8403-009	IF56-318	THERMOSTAT--1 st. cool, 1 stg. heat, Adj. heater Mercury System: Heat-Off-Cool Fan: Auto-On
8403-019	T874C1000	THERMOSTAT--1 stg. cool, 2 stg. heat, Adj. heater, Mercury
8404-012	Q674A1001	SUBBASE --System: Heat-Auto-Cool Fan: Auto-On
HEAT PUMP THERMOSTATS		
Part No.	Model No.	Description
8403-017	T874R1129	THERMOSTAT--1 stg. cool, 2 stg. heat, 1st stage fixed, 2nd stg. adj. heat anticipators
8404-009	Q674L1181	SUBBASE --System switch: Em. Heat-Heat-Off-Cool Fan switch: On-Auto SPECIAL FEATURE: Manual Changeover (Non-Cycling Rev. Valve) Em. heat light and System check light
8403-018	T874N1024	THERMOSTAT--1 stg. cool, 2 stg. heat, 1st stage fixed, 2nd stg. adj., heat anticipators
8404-010	Q674F1261	SUBBASE --System switch: Off-Cool-Auto-Heat-Em.Ht. Fan switch: On-Auto SPECIAL FEATURE: Auto system changeover, Em. heat light and System check light
8403-024	IF58-45	THERMOSTAT--1 stg. cool, 2 stg. heat, 1st stage fixed, 2nd stg. adj. heater System switch: Em. Heat-Heat-Off-Cool Fan Switch: On-Auto

HOW TO SET AN ADJUSTABLE ANTICIPATOR

The primary purpose of the adjustable anticipator thermostat is to provide a single thermostat to match almost any type of primary control in the field today.

Figure 3

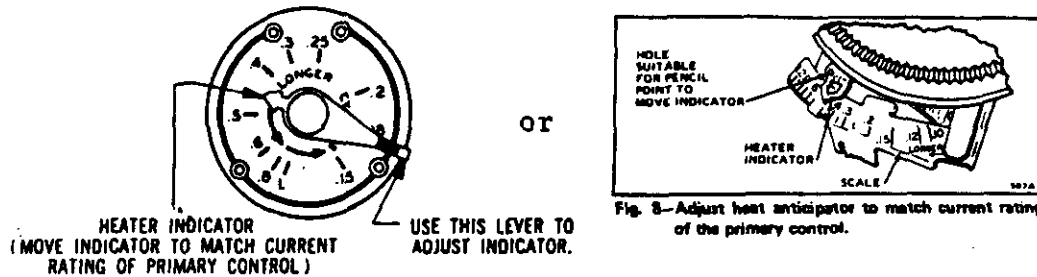

The adjustable heat anticipator has a slide wire adjustment with the pointer scale marked in tenths of an ampere. This is used to set the anticipator to agree with the control amp draw of the control system in use.

If the primary control nameplate has no rating or if further adjustment is necessary, use the following procedure to determine the current draw of each stage.

The current draw of each heating stage must be measured with the thermostat removed and the power on.

1. Connect an AC ammeter of appropriate range between the heating terminals of the subbase.

Stage 1 -- between W1 and RH or R

Stage 2 -- between W2 and RH or R

2. Move the system switch to HEAT or AUTO.
3. After one minute, read the ammeter and record the reading.
4. After mounting the thermostat, set the adjustable heat anticipator(s) to match the respective reading(s) measured in Step 3.

If you want to change the cycle of the heating system, you can make a simple adjustment on the anticipator to do this.

Additional adjustment, if necessary, may be made as follows:

Heater cycles too short--set adjustable heater to a slightly higher dial setting (1/2 division).

Heater cycles too long--set adjustable heater to a slightly lower dial setting (1/2 division).

Occasionally you may find a system where longer or shorter cycles of the primary control are desirable. If the primary control draws .45 amps and you want a longer cycle, set the anticipator to .5 or .6 amps. This puts less resistance in the circuit. With less resistance, but the same current (from the primary control), you will generate less "false" heat and get a longer cycle of the primary control.

If a setting of .45 amps on the adjustable anticipator gives a cycle that is longer than desired, reset the indicator to .3 or .25 amps. This will put more resistance in the circuit and thus generate more "false" heat for shorter cycles.

ADDITIONAL INFORMATION FOR ELECTRIC HEAT OR HEAT PUMP APPLICATIONS

Adjust heat anticipator to match current rating of heating relay for W1 (and W2 if 2 stage). Move indicator on the scale to correspond with this current rating.

If the current rating is not given, proceed as follows:

1. Wrap exactly 10 loops of thermostat wire (W1) around the prongs of an Amprobe.
2. Let the heating system operate for one minute before reading the W1 or W2 current draw.
3. Divide the reading obtained in Step 2 by 10.
4. Use the value calculated in Step 3 to set the heat.
5. Repeat the procedure for (W2) if 2 stage heat anticipator.

NOTE: Cooling anticipators on all thermostats are fixed and do not require setting.

FIGURE 4

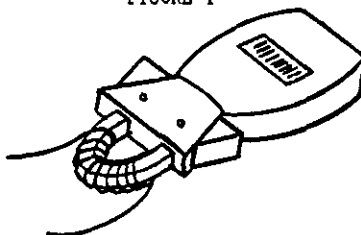

Example: $\frac{6.0 \text{ Amp}}{10 \text{ loops}} = .6A$

III. SERVICE

TWO SPEED BLOWER MOTOR

The BC48A and BC60A both have a two speed, 1/2 hp blower motor.

Motor lead wire identification is as follows:

Common	Yellow
High	Black
Low	Red
Capacitor	Brown (2)

Both models are shipped wired on high speed. The unused red (low speed) lead wire is taped off. If low speed operation is desired, remove and tape black wire from terminal 6 on blower relay and connect red wire to terminal 6. Refer to wiring diagrams for electrical circuitry and to airflow charts for capabilities and limitations on blower speeds, static pressures, and air delivery versus installed KW heaters.

BLOWER MOTOR OILERS

The blower motors should be oiled twice a year with approximately 8 - 10 drops of 20 weight motor oil. DO NOT over oil and DO NOT use 3-in-1 oil or any other light oil.

IMPORTANT NOTE FOR DOWNFLOW INSTALLATION: Loosen belly-band bolt securing motor enough to rotate motor so oilers are above either 3 or 9 o'clock position so oilers do not drain and to permit reoiling.

FILTER

These units come equipped with a 24" x 24" x 1" thick disposable fiberglass filter and must not be operated without a filter in place. Filter access is gained by removing an angle piece located at the bottom of the main unit cabinet (as viewed in upflow position).

The filter should be replaced periodically throughout the year, as these are year-round heat-cool systems. Special attention should be given to filter cleanliness on any new installation, as airborne dust and debris from recent construction can easily plug a filter in a matter of days.

Dirty filters are the most prevalent and most easily corrected problem to be encountered in any forced air heating and/or cooling system.

COMPRESSOR MALFUNCTION RELAY

Actuation of the green "check" lamp is accomplished by a voltage type relay which is factory installed and located in the outdoor unit on 1 phase units only. The compressor malfunction relay is optional and must be field installed on all matching 3 phase outdoor units.

THERMAL CUT-OFFS AND LIMIT CONTROL

A thermal cut-off is installed for each 3, 4 or 5KW segment of the installed electric heaters (9kw--three 3KW, 15KW--three 15KW, etc.). These are a back-up safety device to the primary safety--the high limit control. The thermal cut-offs are located in the heater mounting plate in the control compartment, and are a one-shot device. They must be replaced with an identical part should they function.

The high limit control is an automatic reset device and controls the operation of the electric heaters during any abnormal condition: dirty filters, closed registers, defective blower motor, etc.

Access to the limit control is gained by removing a 6" x 8" plate, secured by four (4) screws. This plate is attached to the blower deck to the left of the blower housing (when viewing the unit in upflow position from access panel side). It is not absolutely necessary, but desirable to remove the blower housing for easiest access.

Refer to Installation Instructions
for Control Circuit Wiring

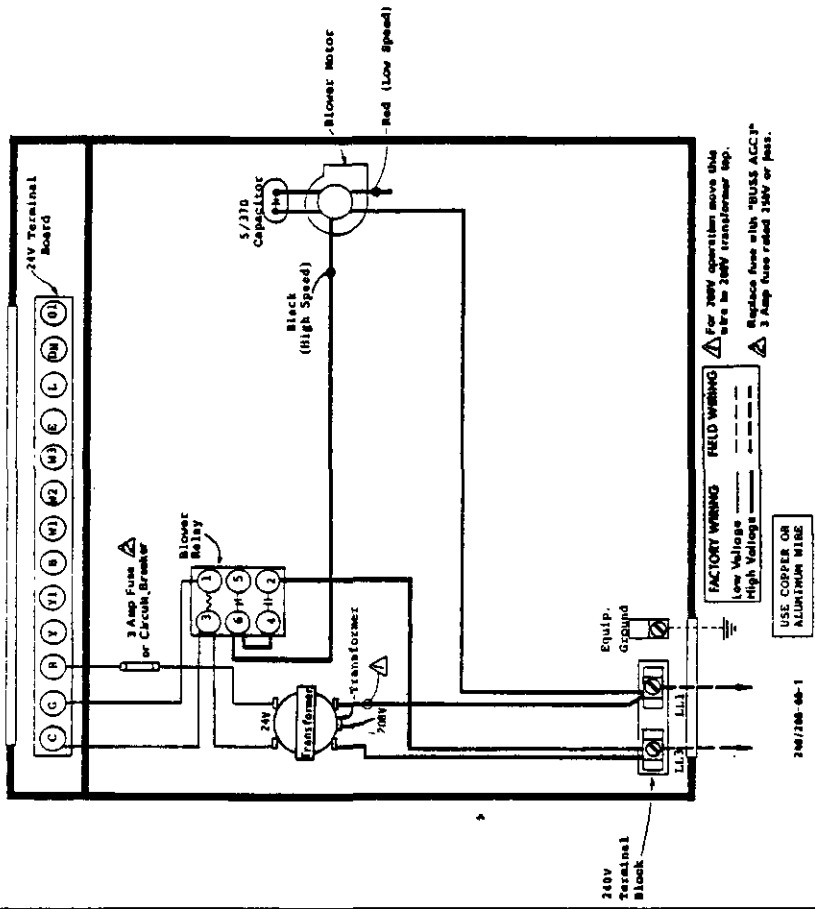

Models
BC48A & BC60A

Refer to Installation Instructions
for Control Circuit Wiring

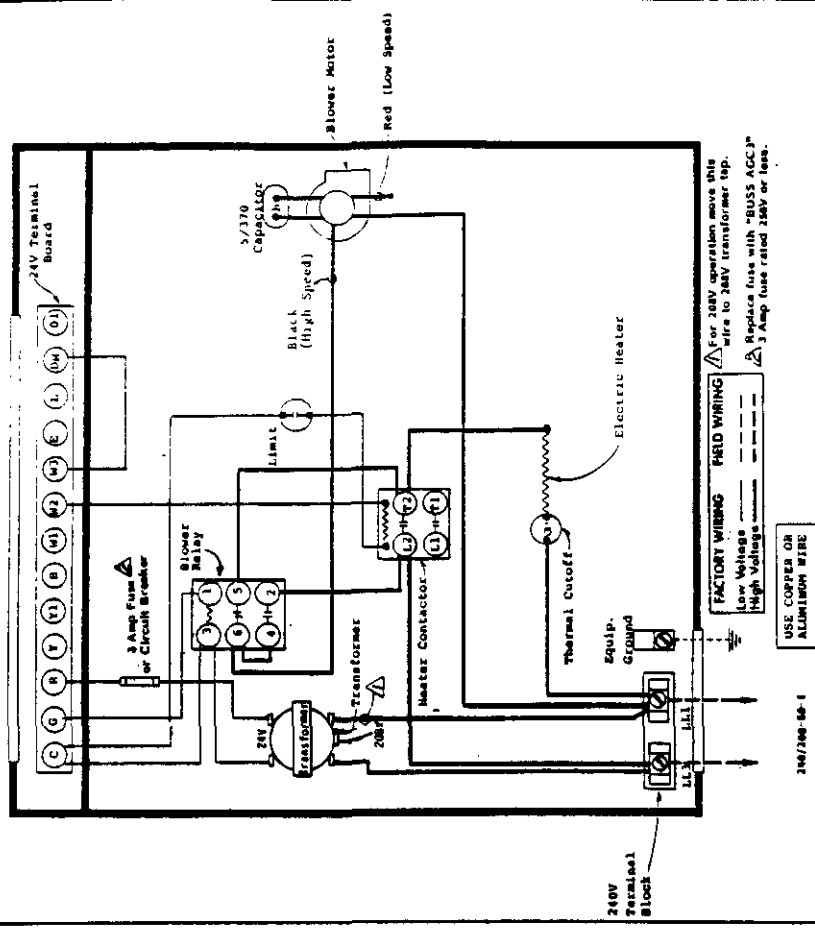

Models
BC48A & BC60A

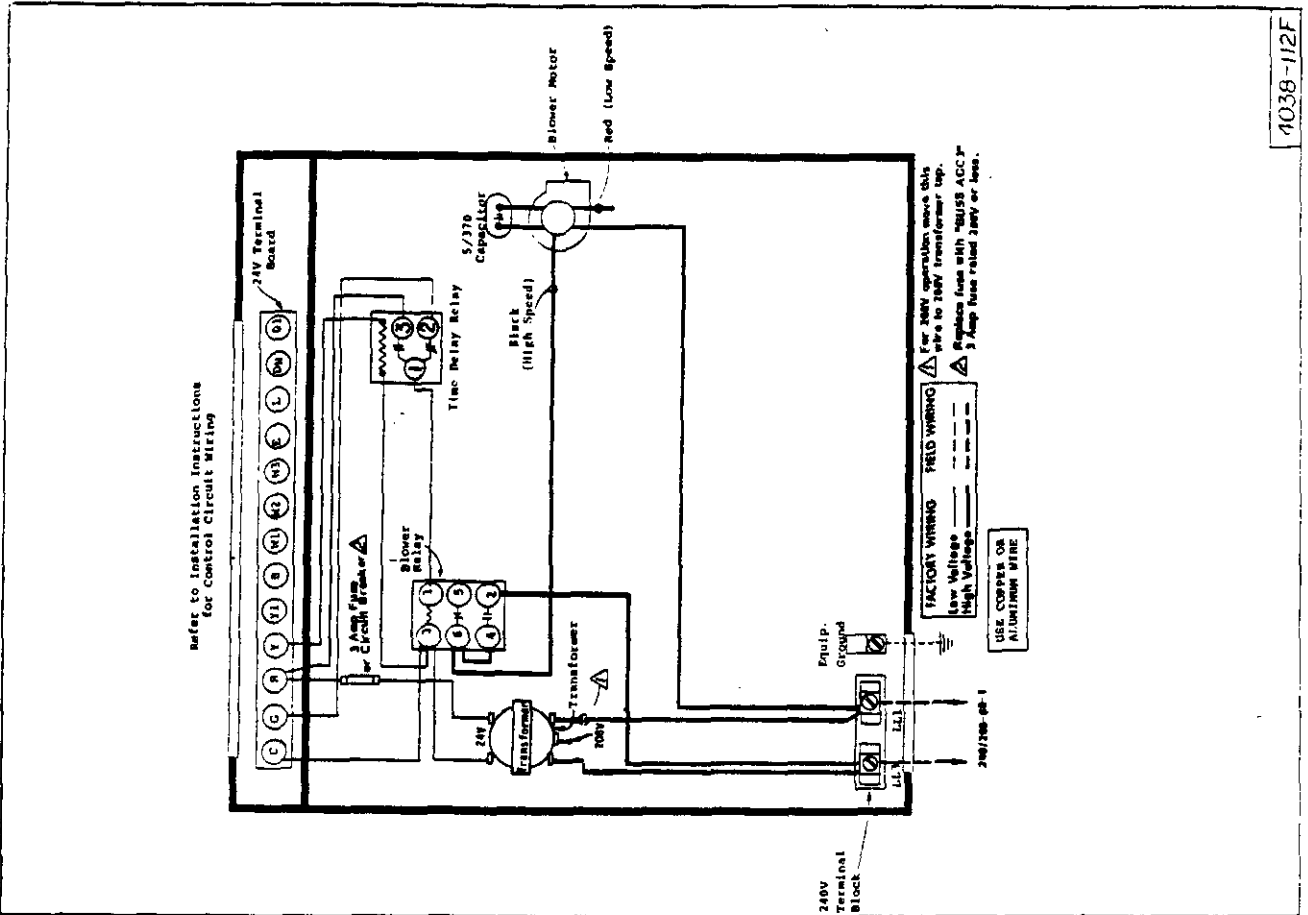

4038-112F

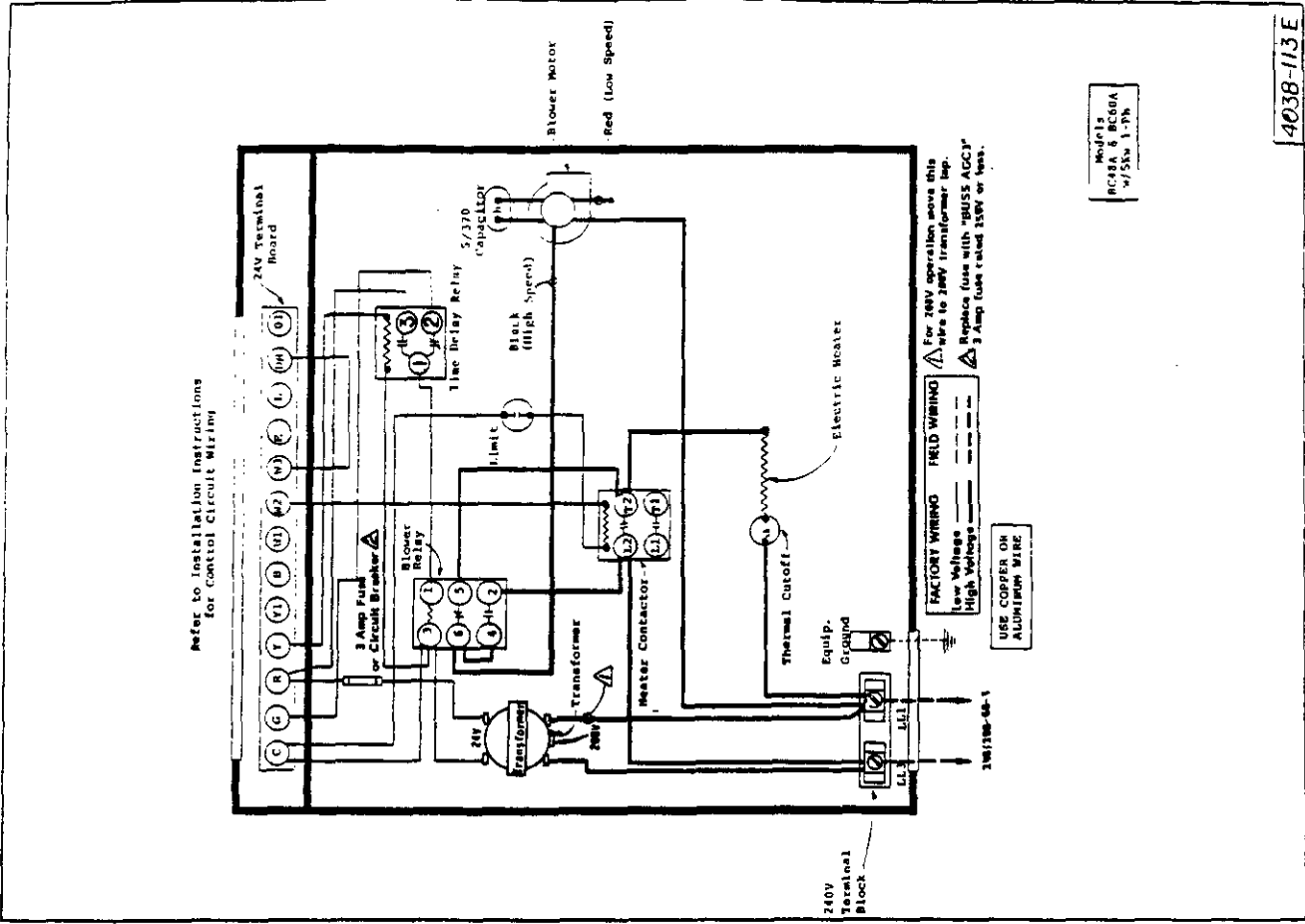

Models
BC48A & BC60A
w/5kw 1-7kw

4038-113E

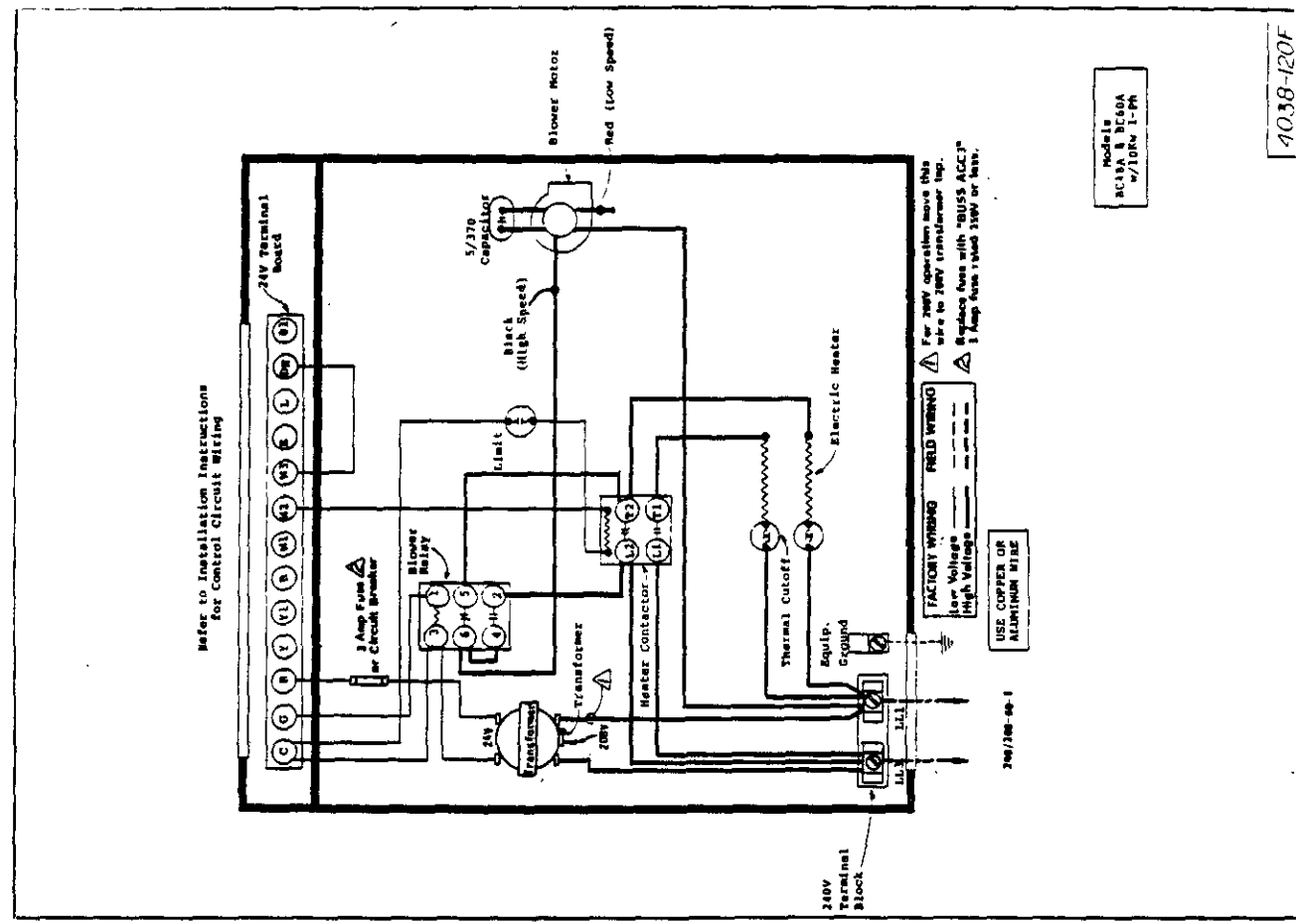

Models
 BC19A & BC60A
 w/108v 1-PH

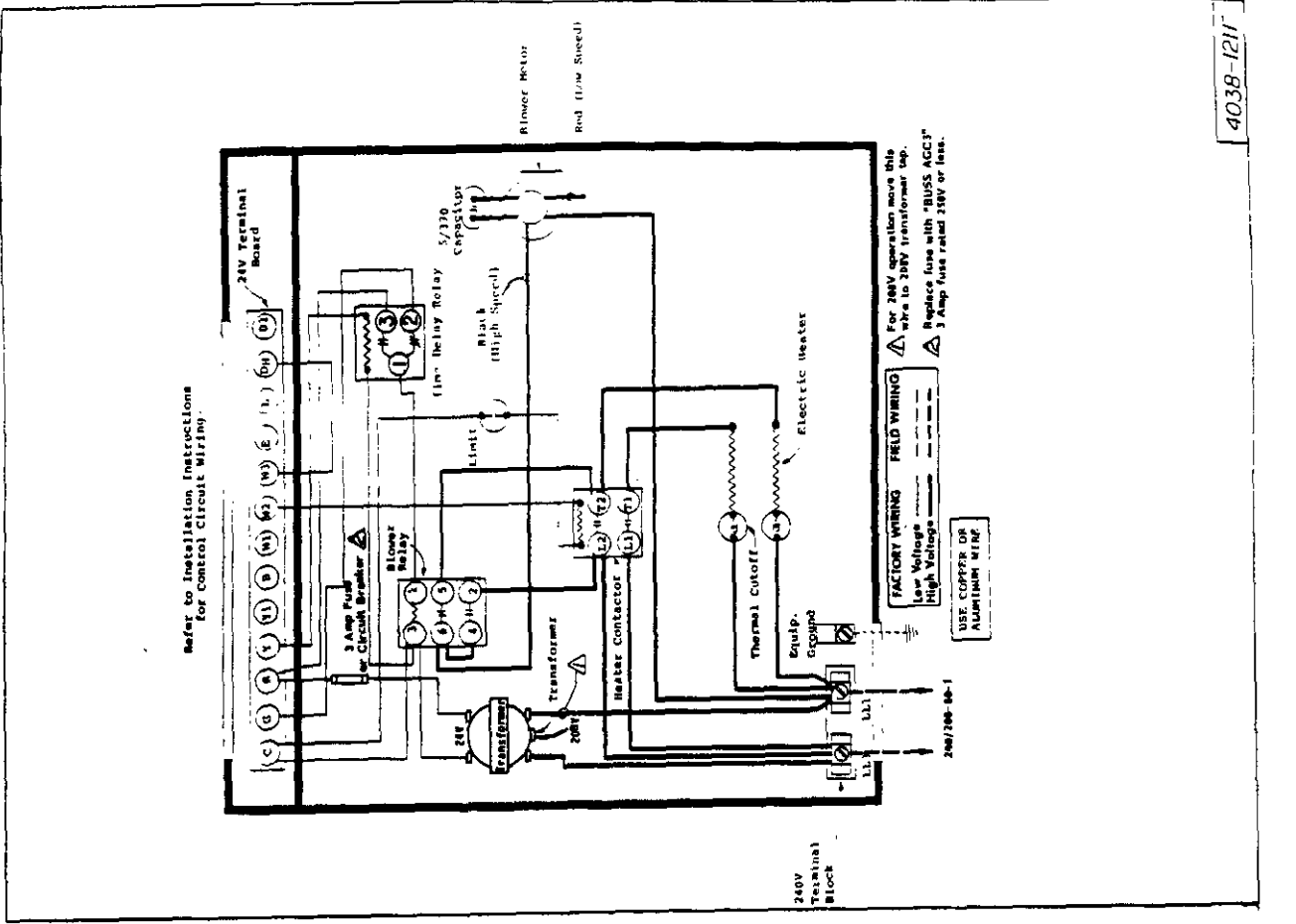

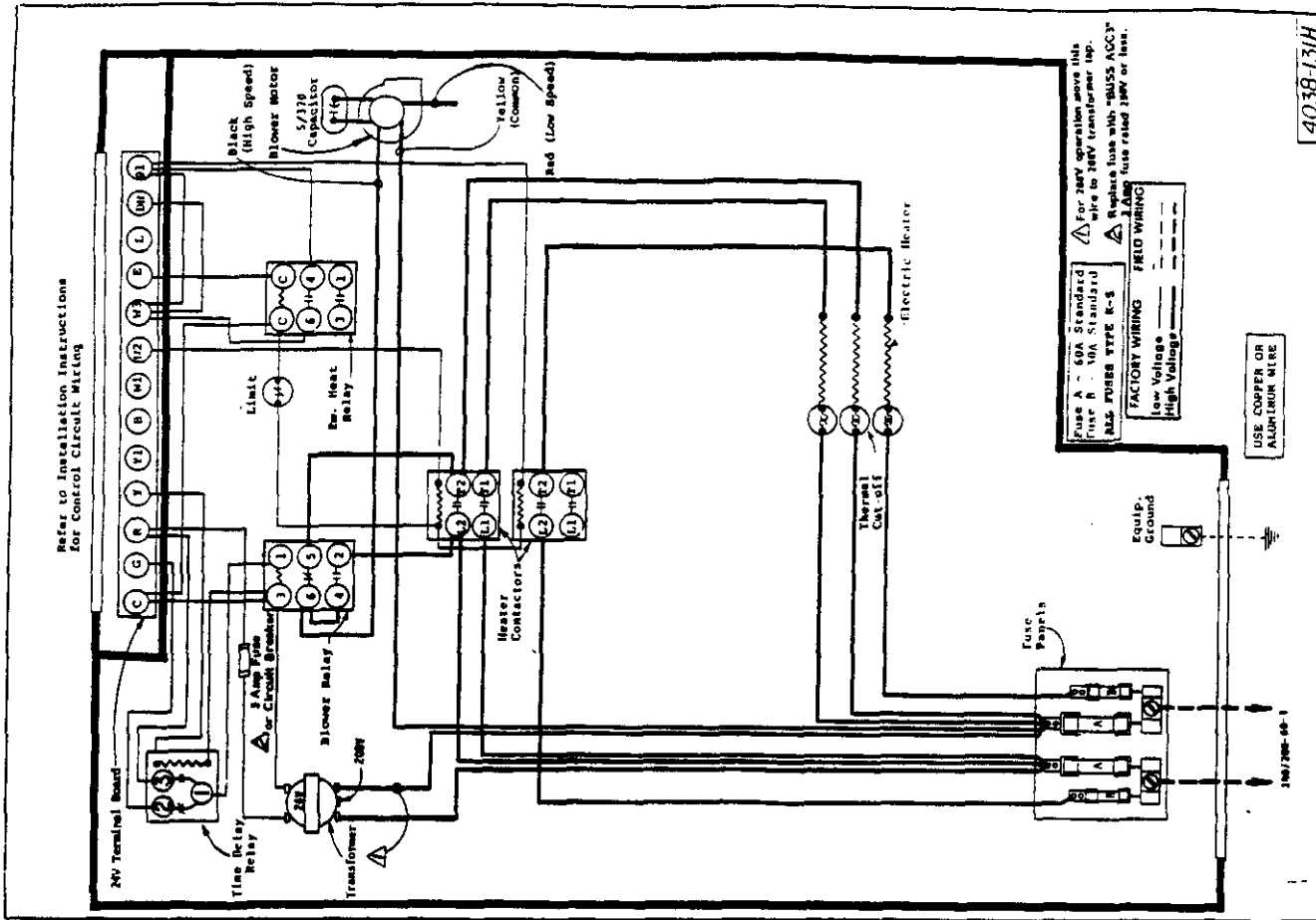
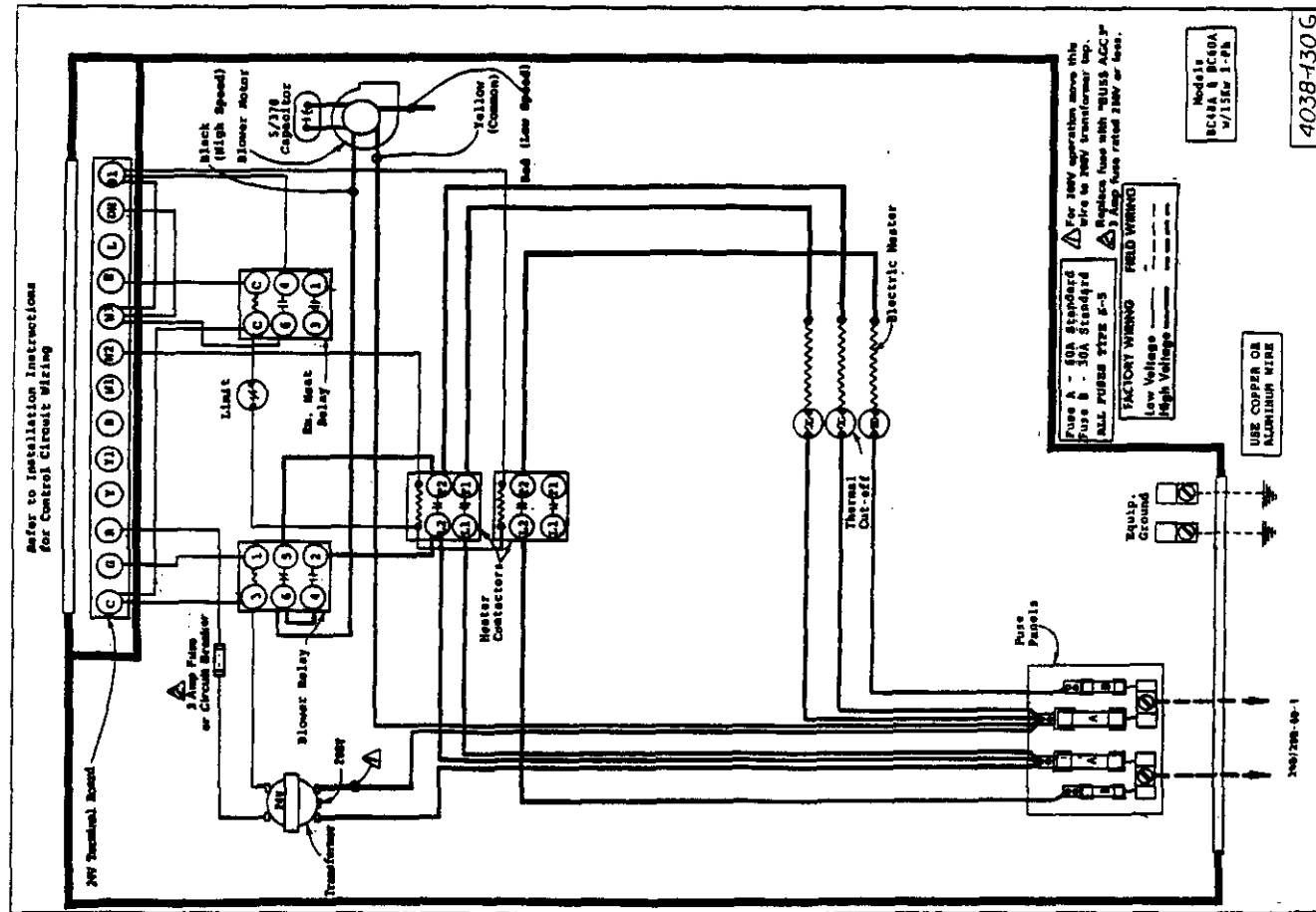

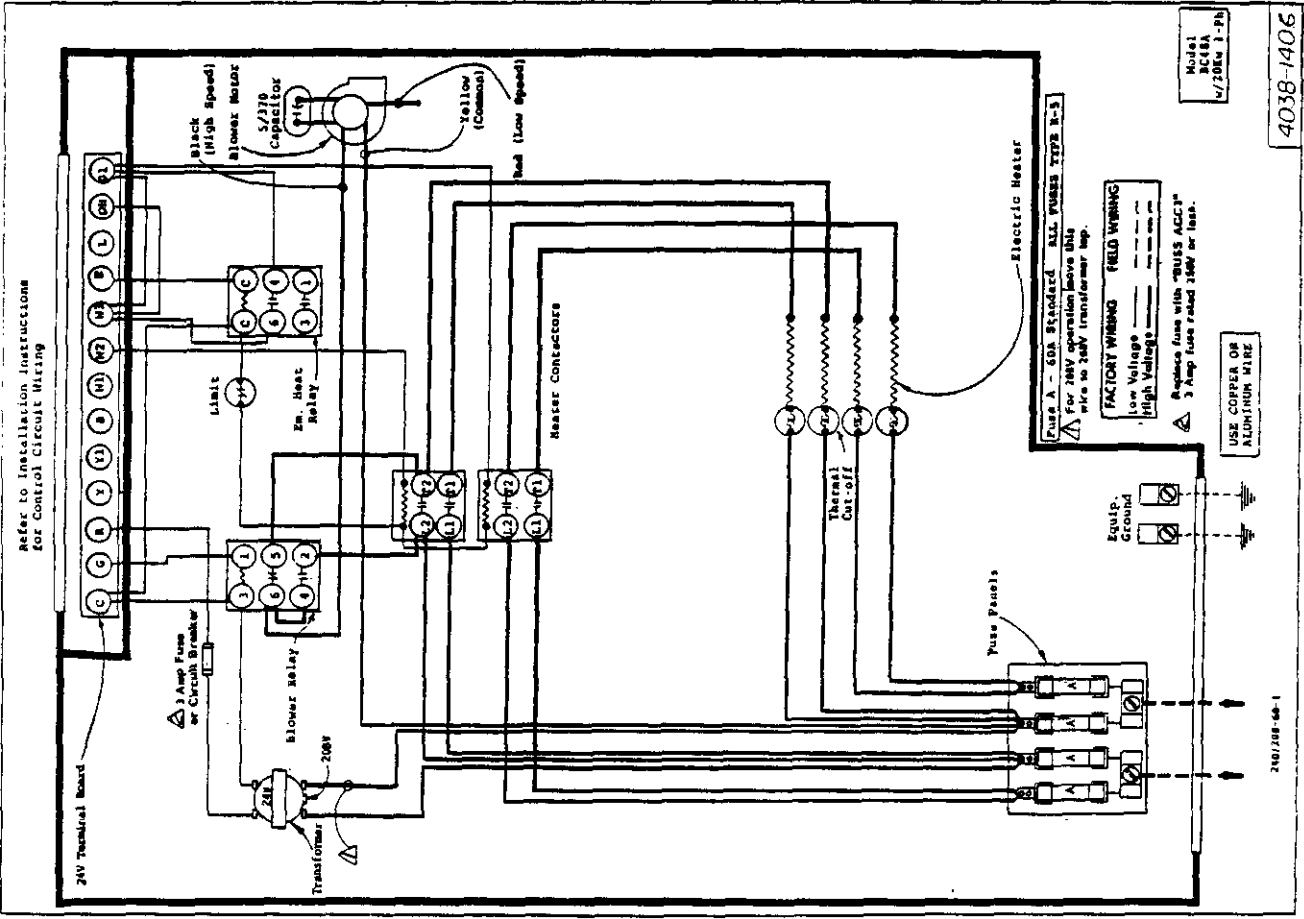
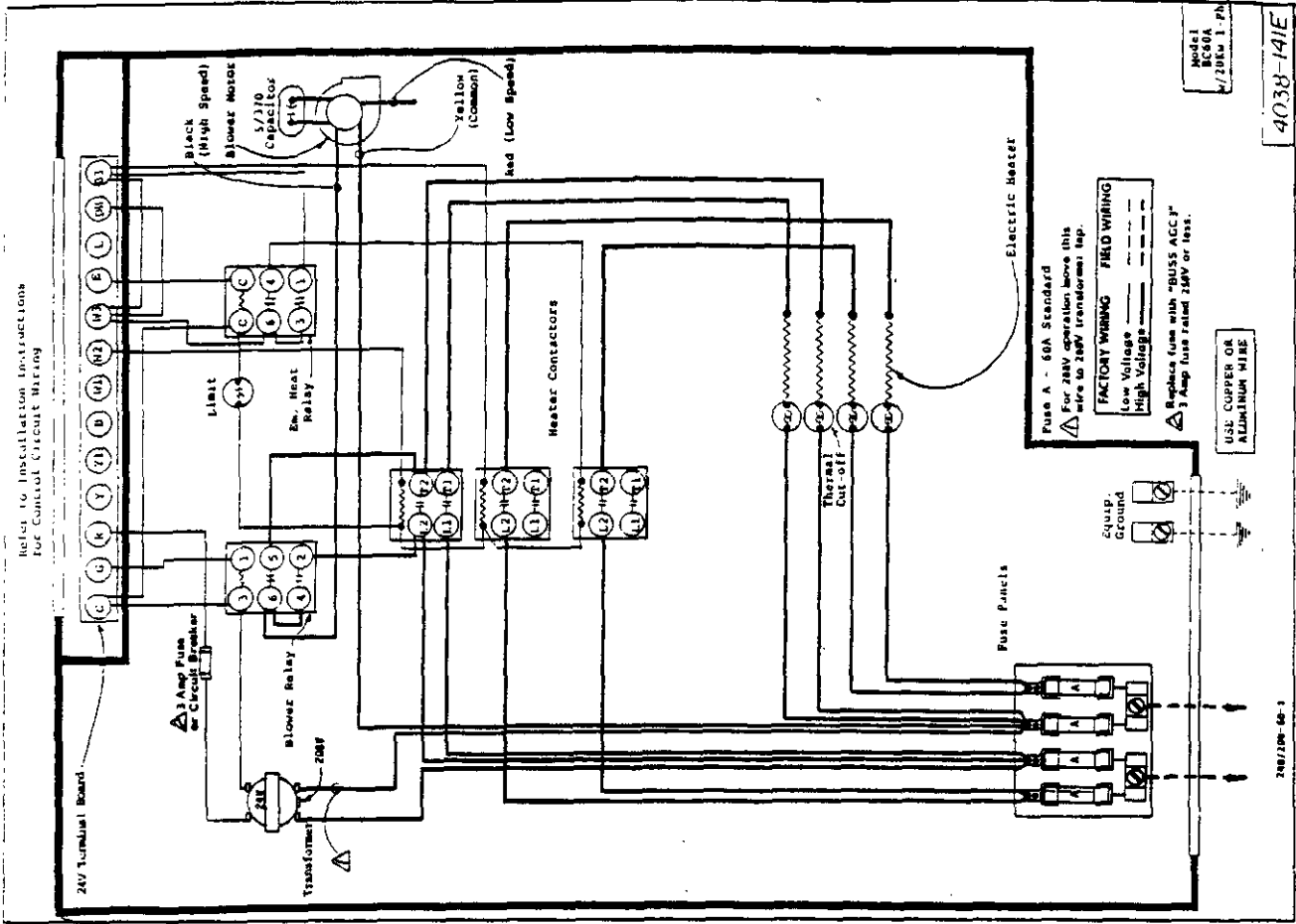

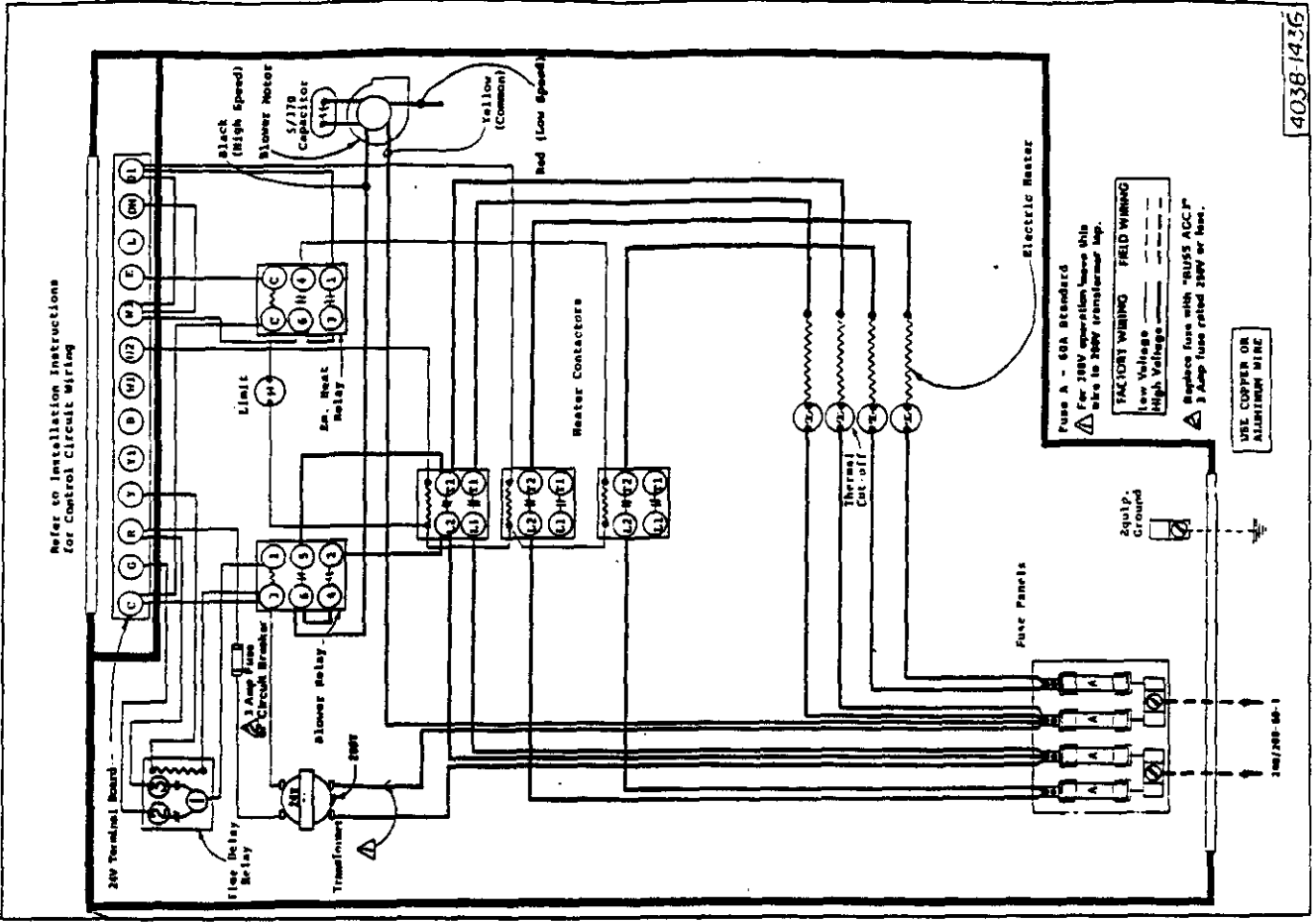
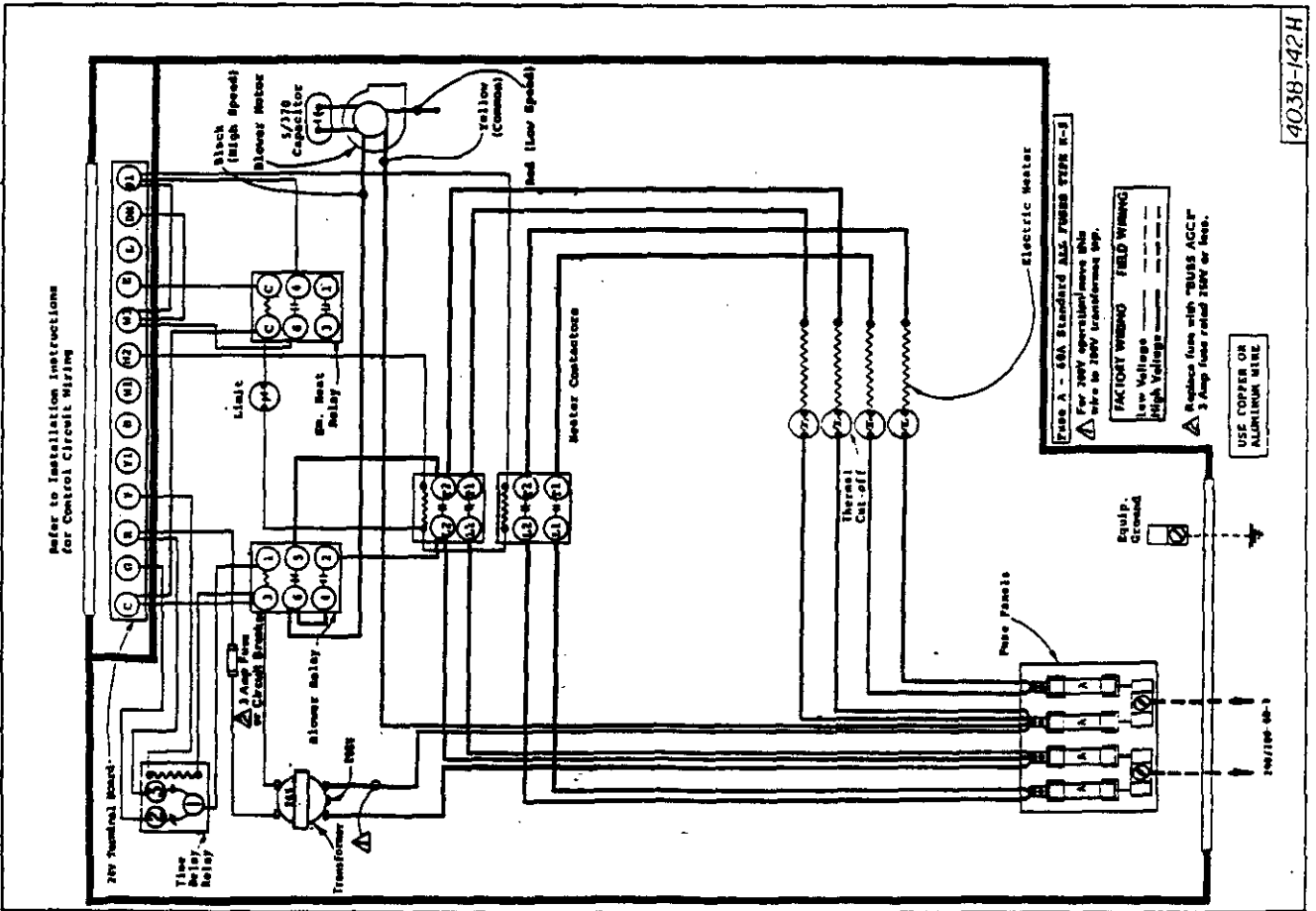

Refer to Installation Instructions
For Control Circuit Wiring

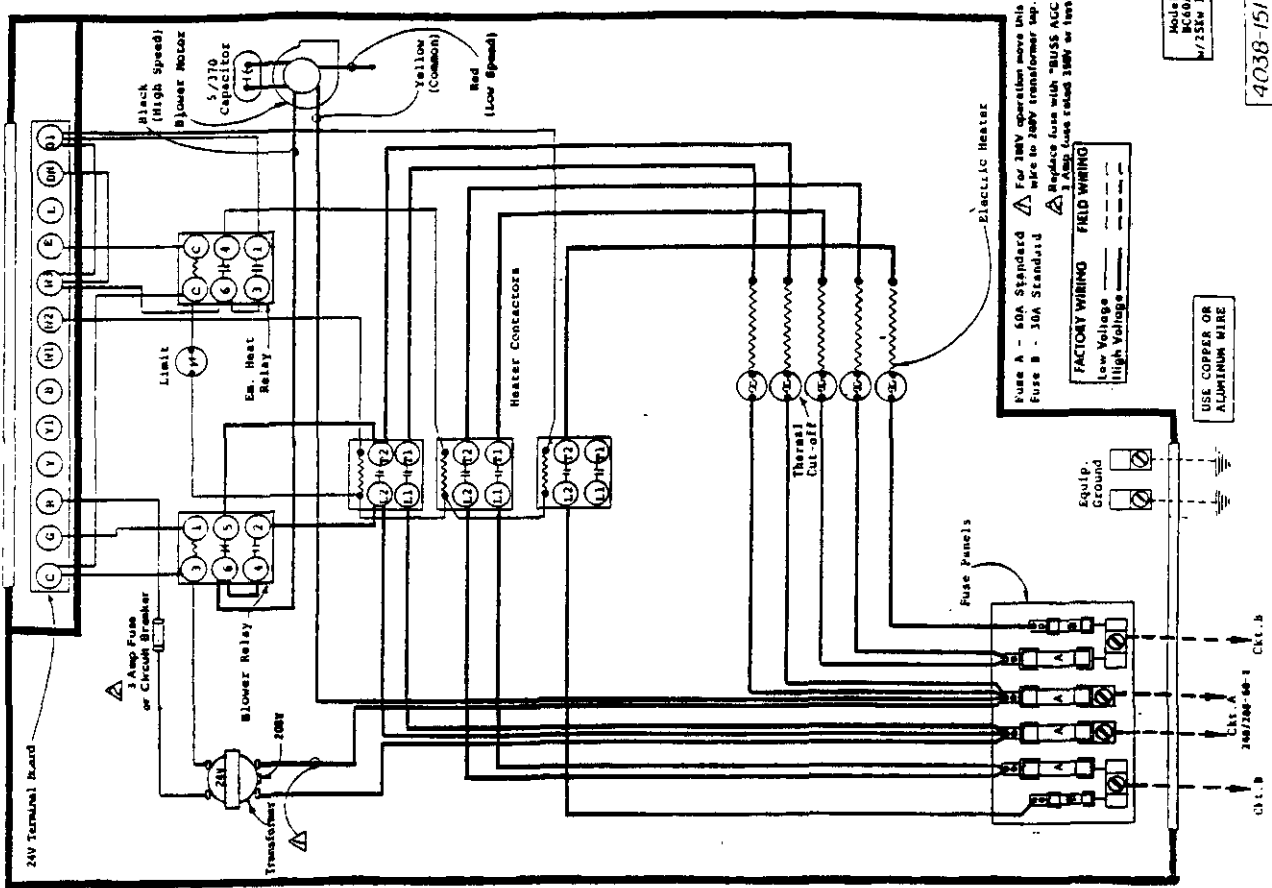

Refer to Installation Instructions
For Control Circuit Wiring

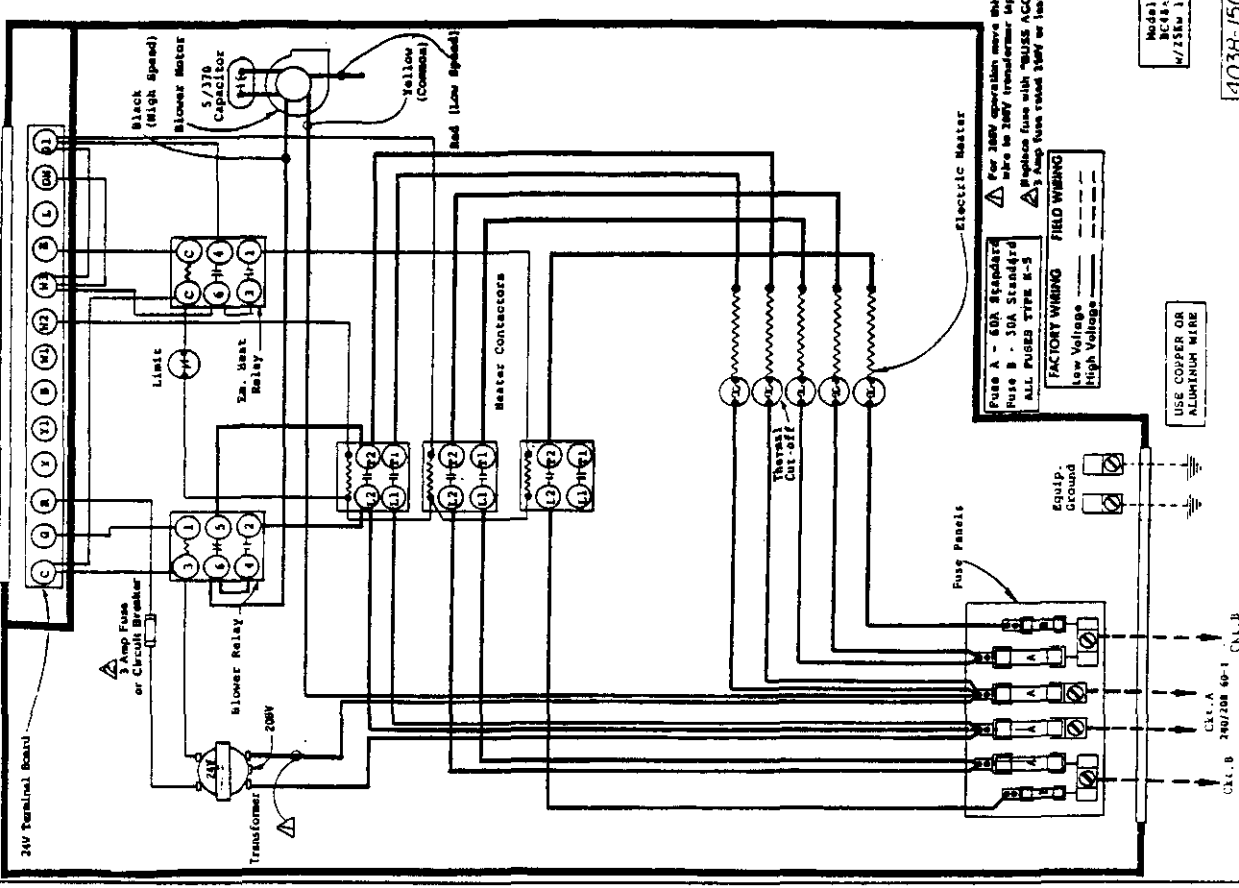

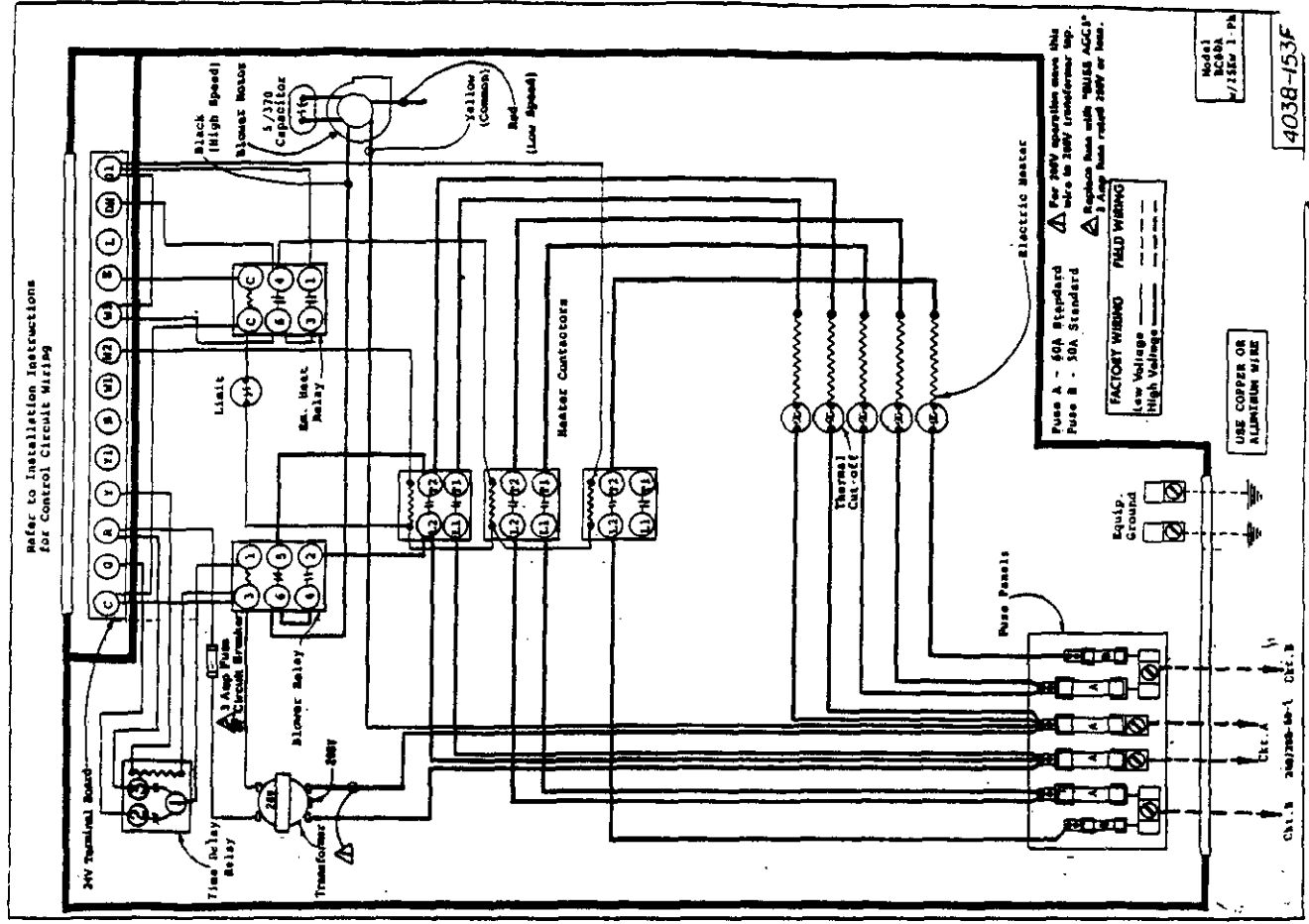
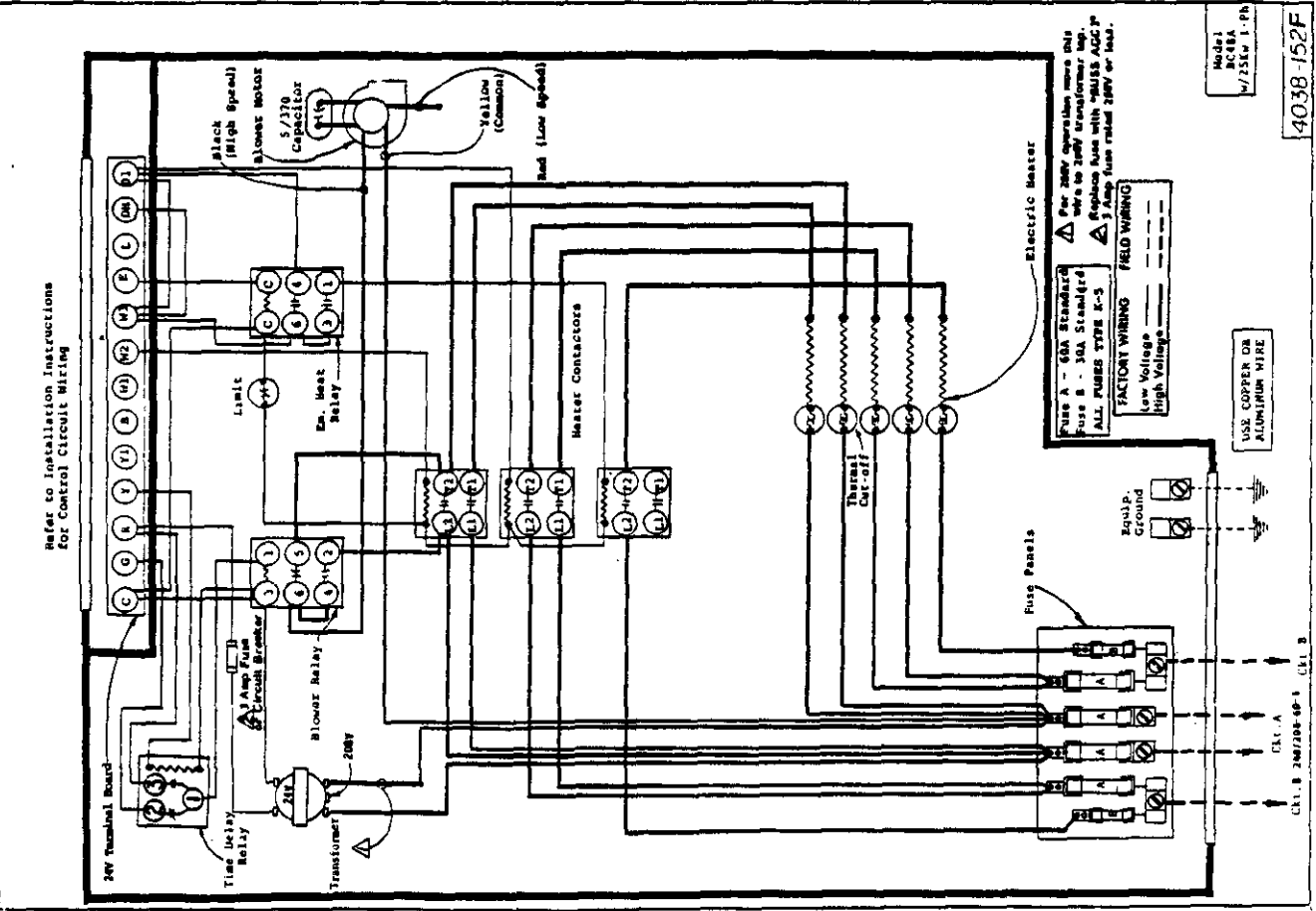

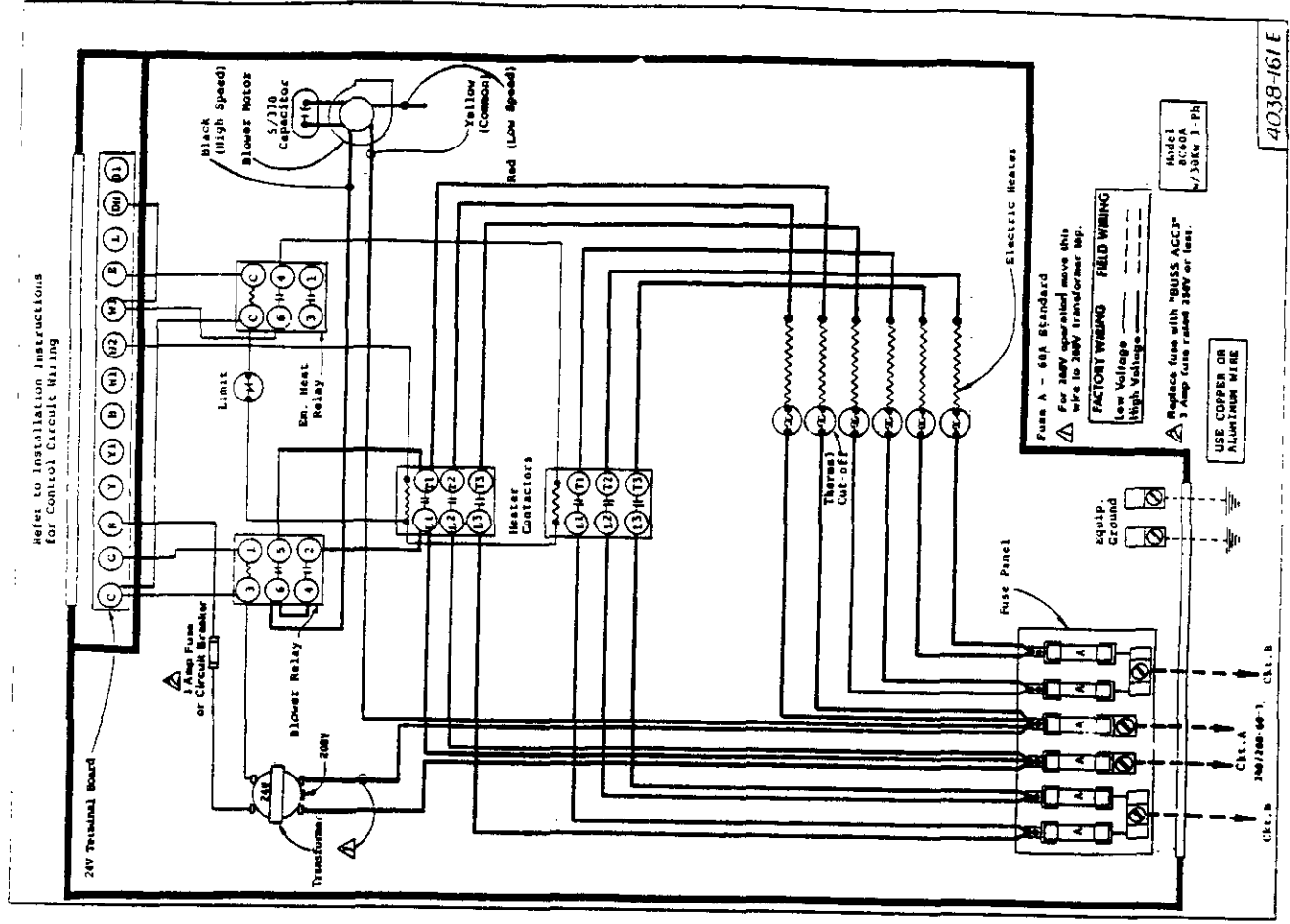
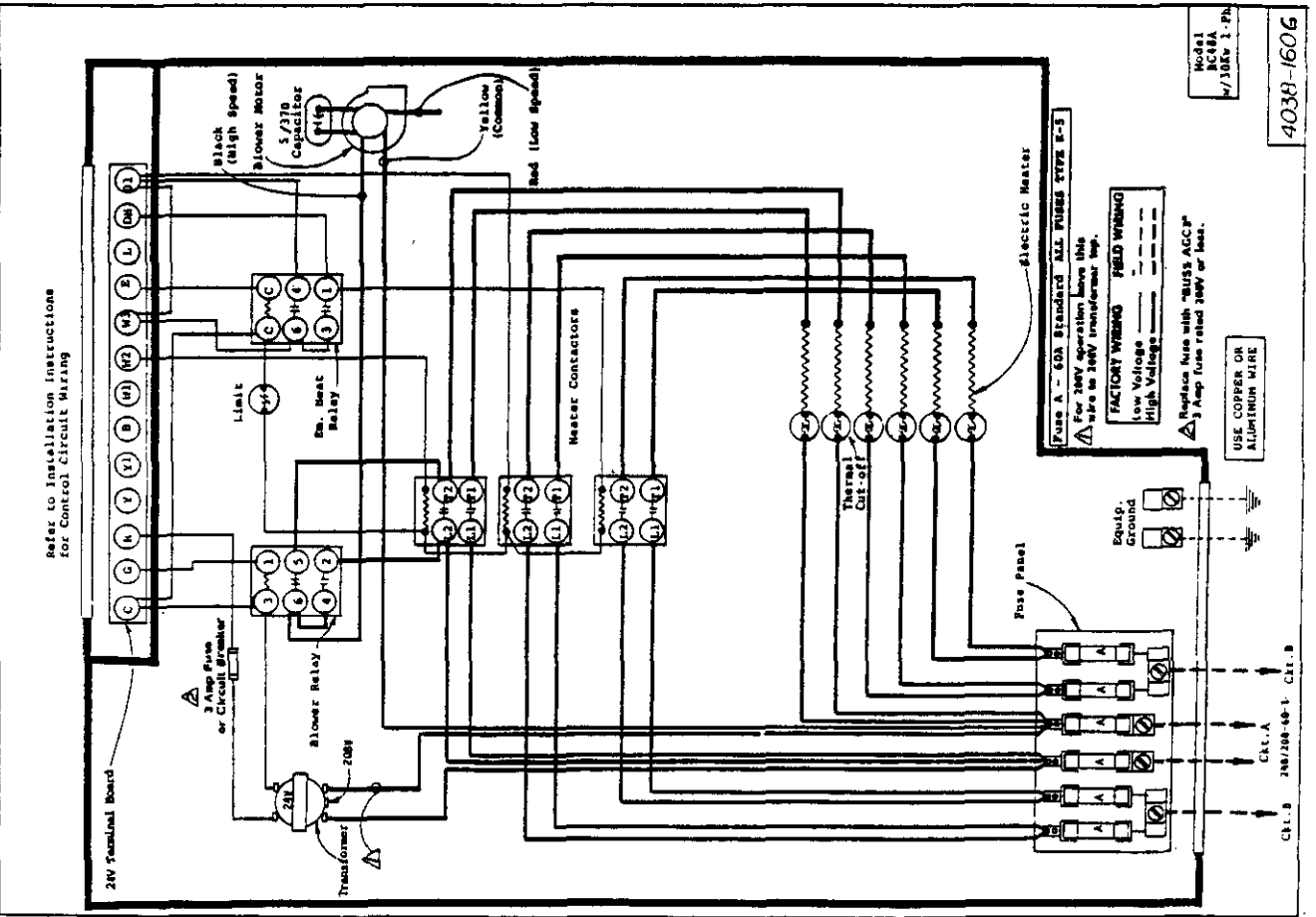

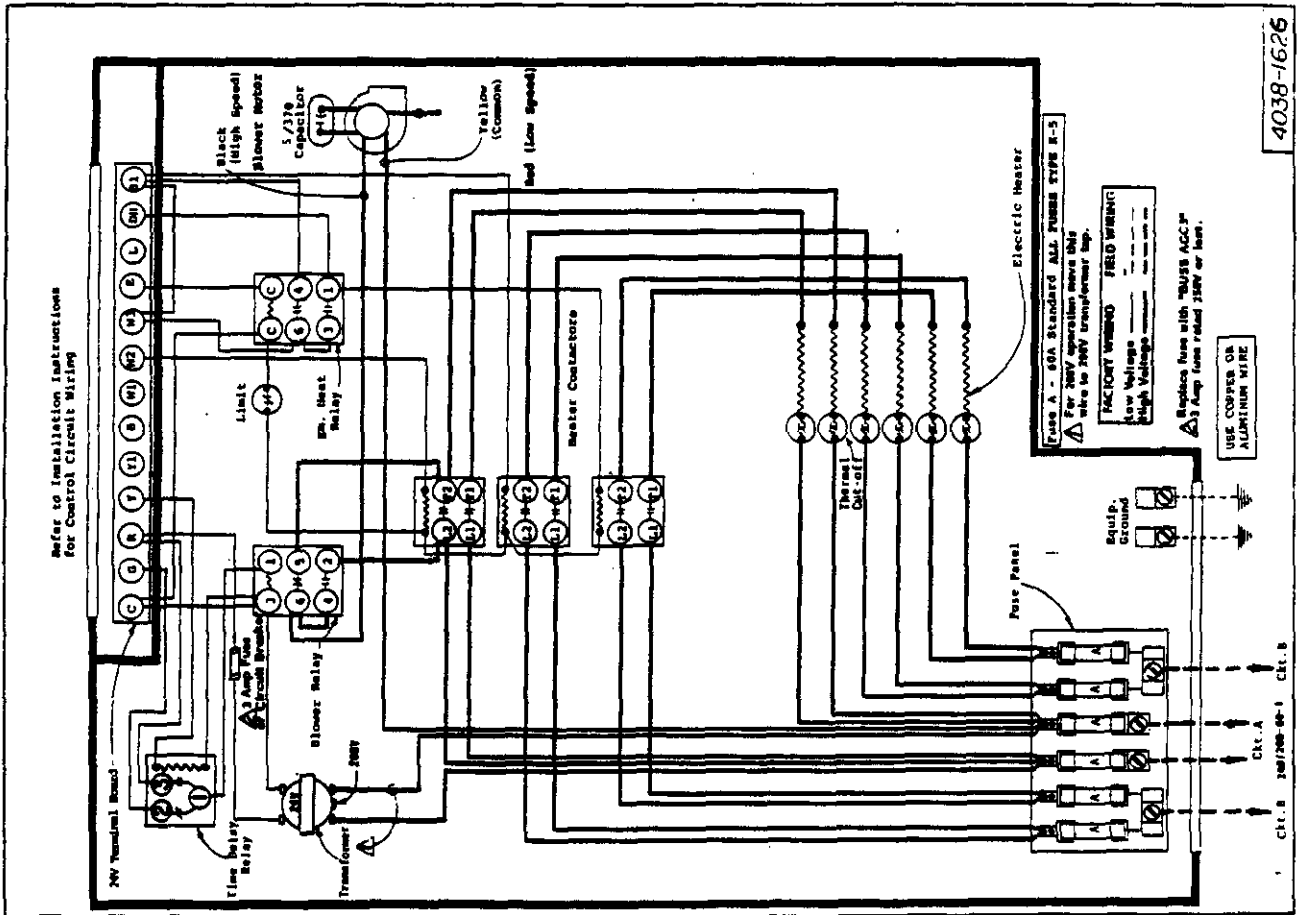
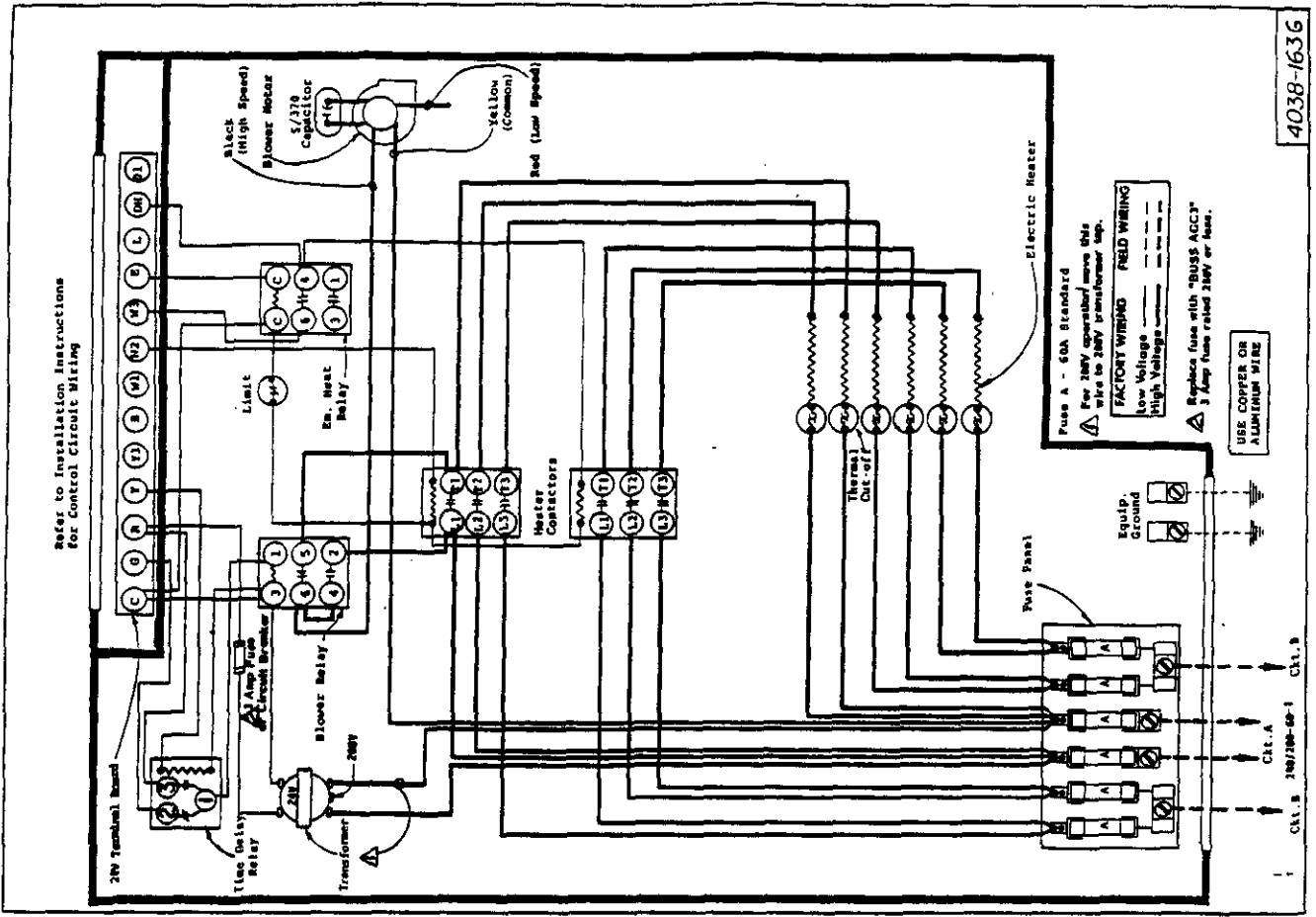

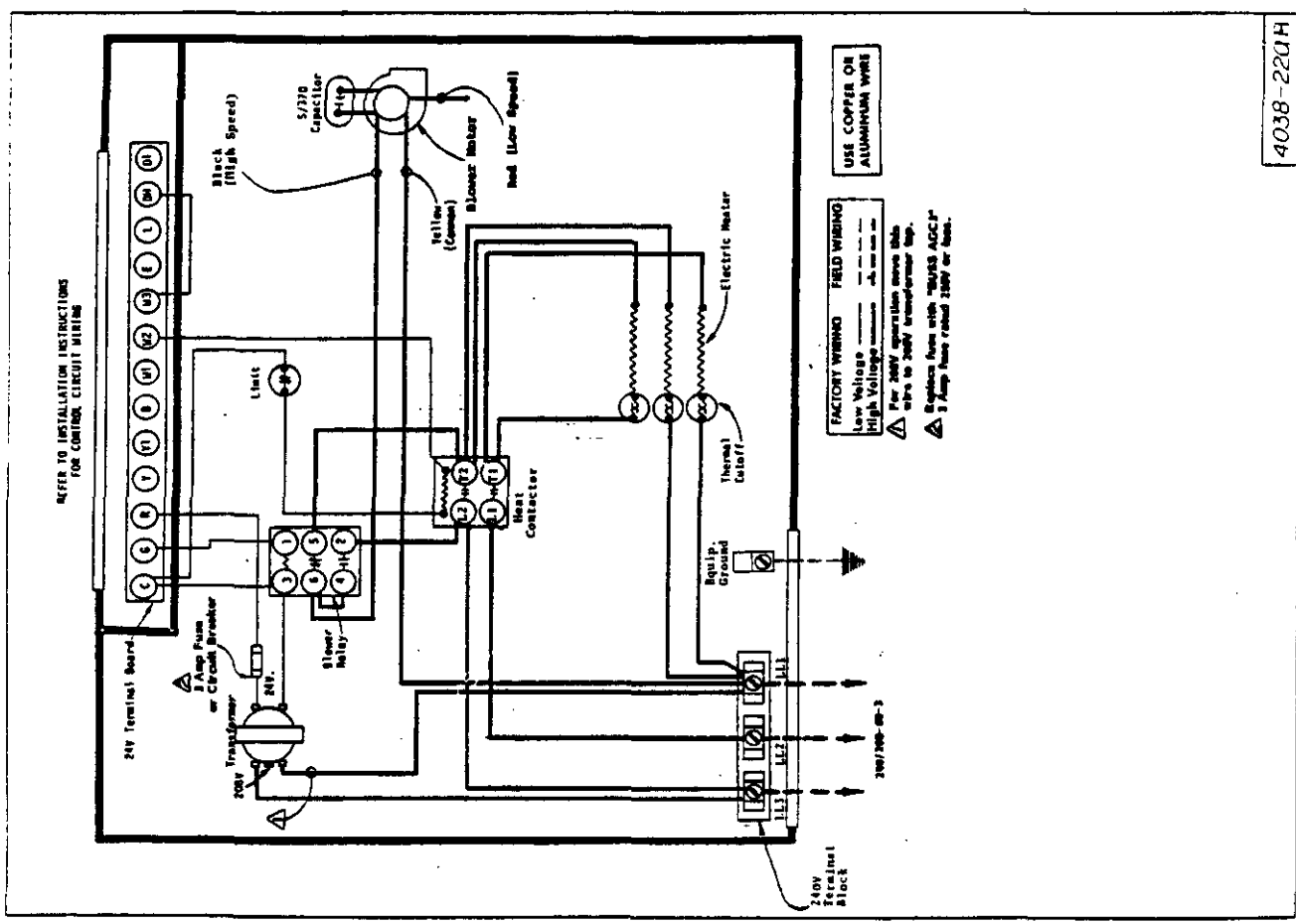

4038-220H

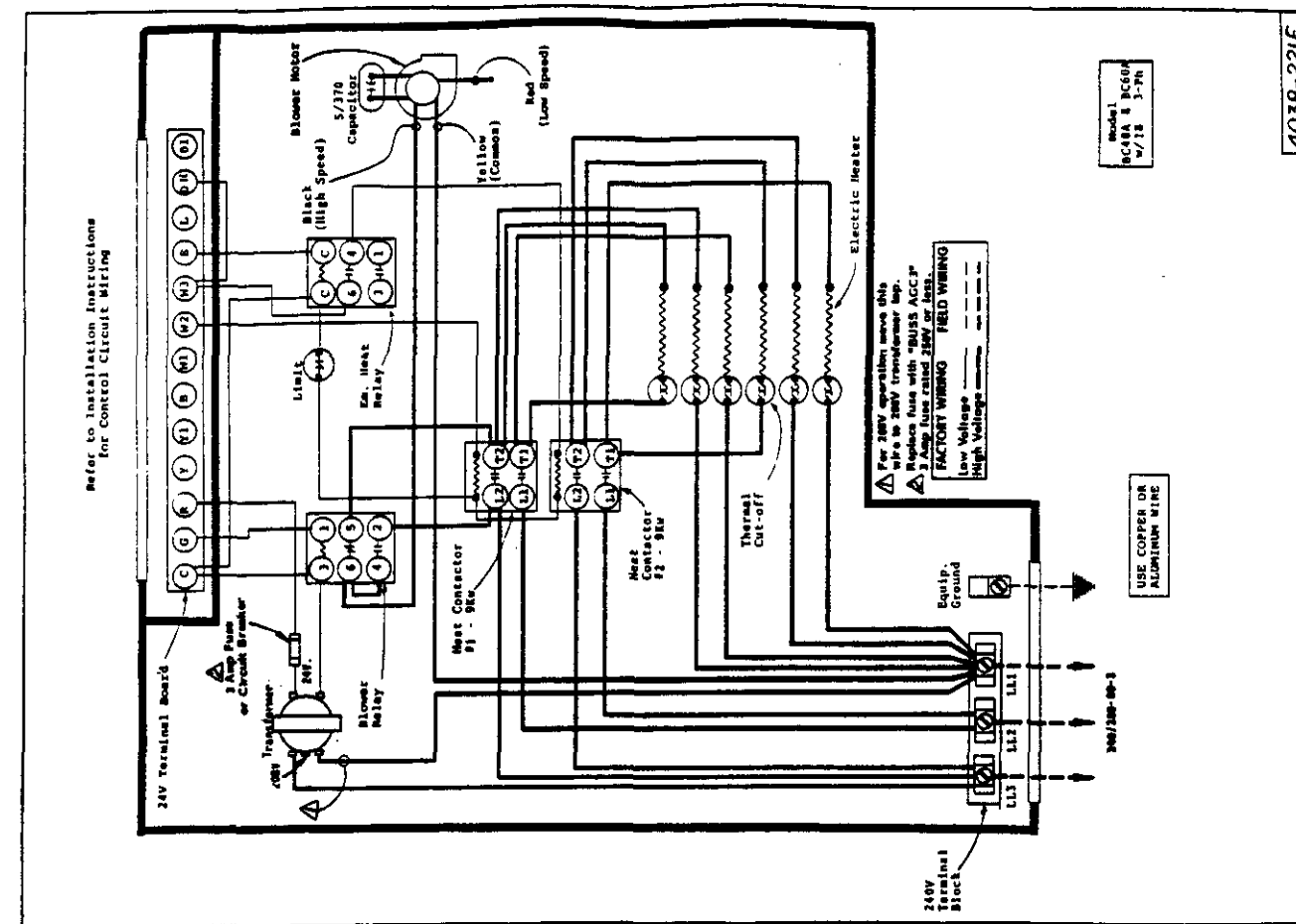

Model
4038 & 4040
9/78 1-79

4038-221F

