

**OIL FURNACE
INSTALLATION INSTRUCTIONS**

INSTALLATION AND OPERATING INSTRUCTIONS FOR OIL FURNACES

LOCATION

When installing the furnace be sure to provide adequate space for easy service and maintenance. Locate the furnace as close to the chimney as practical, giving consideration to the accessibility of the oil burner, controls, and blower for service. Allow a minimum of 24 inches at front of furnace for servicing oil burner. Allow enough room at the rear of the furnace to change filters and remove the blower. Clearance from combustible material as stated on the furnace must be maintained. If close clearances are not stated, use the recommended standard clearance (see Table) or clearances permitted by local codes. For basement installation, a raised concrete pad is recommended. This will keep the bottom of the furnace dry and reduce rusting.

On knocked down units, assemble according to the installation instructions packed with the unit.

If the counterflow models are to be installed on combustible material, a "combustible floor base" must be used. Please refer to serial plate on unit and table below for side, top, back and flue pipe clearances from combustible material.

An oil burner must have a generous supply of combustion air to operate properly. The flow of combustion and ventilating air must not be obstructed from reaching the furnace.

The furnace area must be kept clear and free of combustible materials, gasoline and other flammable vapors and liquids.

WIRING

All units are factory wired with the exception of the unassembled or knocked down units. All wiring must conform to the National Electrical Code and all local codes. A separate fuse or breaker should be used for the furnace. If replacement wire is necessary, use 105°C, 16 gauge wire.

OIL LINE PIPING

First determine whether the pipe system is to be a single line system or a two line system. After determining the best piping system for the application, refer to the pump specifications on page 6. All connections must be absolutely air tight or you will have a malfunction of the burner. When installing the piping, a good oil filter should be installed close to the burner. A single line system is recommended for gravity feed.

OIL BURNER

Most units are shipped with the oil burner installed. Inspect firepot refractory before firing to be sure it has not been jarred out of position in shipment. Burner air tube must not extend beyond inside surface of firepot, preferable location is 1/8 inch from inside surface.

CAUTION: Never attempt to use gasoline in your furnace. Gasoline is more combustible than fuel oil and could result in a serious explosion.

BURNER ADJUSTMENT

All oil burner installations should be performed by a qualified installer in accordance with regulations of the National Fire Protection Standard for Oil-Burning Equipment, NFPA No. 31, and in complete compliance with all local codes and authorities having jurisdiction. A qualified installer is an individual or agency who is responsible for the installation and adjustments of the heating equipment and who is properly licensed and experienced to install oil-burning equipment in accordance with all codes and ordinances.

The proper installation and adjustment of any oil-burner requires technical knowledge and the use of combustion test instruments.

Checks and Adjustments

1. Check all oil lines for leaks.
2. Check fuel pump pressure and adjust to 100 psig if necessary.
3. Drill 1/4 inch hole in flue pipe between flue outlet of furnace and barometric damper for draft measurement. Adjust barometric damper to obtain approximately .04 inches water column draft in flue pipe. Check draft overfire. For this measurement the burner observation port may be utilized. Draft overfire should be approximately .02 inches water column. It may be necessary to readjust barometric damper to obtain proper draft. Upon completion of draft readings, plug 1/4" hole in flue pipe with a sheet metal screw after making smoke check and taking stack temperature.
4. **Air Adjustment.** The air intake is located on the left side of the blower housing and consists of two interlocking bands. To adjust, loosen screw in outer band and position band by rotating to the desired opening. Retighten screw after adjustment to assure permanent adjustment.

Sufficient air should be introduced into the fire until a minus 1 smoke or trace of smoke is obtained. (Check with smoke tester). The screws should then be locked in position. After this has been set, check the top of the chimney on the outside. There should be a very slight haze, not smoke, coming out of the same. On a cold stack in extreme cold weather a white haze may come out of the chimney. This is due to the chilling of the gases and will correct itself as the chimney warms up. Any type of automatic fuel being burned in extreme cold weather will bring about the same chimney condition.

The MSR model oil burners which are standard equipment for the furnace do not require any air cone or baffle plate adjustment.

5. Check combustion efficiency of the unit while hot. The hole in the flue pipe upstream of the barometric damper should be used for the CO₂ and temperature readings. If combustion efficiency is not 75% or greater, determine cause and make necessary adjustments.

MINIMUM CLEARANCES - INCHES											
Model	Minimum Installation Clearances								Minimum Service Clearances		
	Top	Front	Vent	Back	Sides	Plenum	Duct 	Floor	Front	Back	Sides
F81	1	8	9	2	2	1	1	NC	24	24	18
F97	1	8	9	6	2	1	1	NC	24	24	18
F120L	2	8	9	2	2	1	1	NC	24	24	18
NB120	1	8	9	6	2	1	1	NC	24	24	18
C1	2	8	9	2	6	1	1	NC	24	28	18
C2	2	8	9	2	6	1	1	NC	24	28	18
F86H	1	8	9	1	1	1	1	C	24	--	--
F120H	2	8	9	2	2	1	1	C	24	--	--
F86CF	2	8	9	2	2	1	1	*C	24	--	--
F100CF	2	8	9	2	2	1	1	*C	24	--	--

*With combustible floor base. NC - Non-combustible. C - Combustible.
 For the first three feet from plenum.

BURNER NOZZLE

Check nozzle size as to conformance to installation requirements. Install nozzle by screwing into hexagon adapter.

Nozzle Adapter. This burner is equipped with a dribble-proof nozzle adapter which will accomplish intended results only when installed with the stamped word "TOP" in the correct position.

Spacing of Electrodes. The electrodes should be spaced 1/8 inch apart. They should extend 1/8 inch beyond the end and 1/2 inch above the center of the nozzle tip as shown in the drawing below.

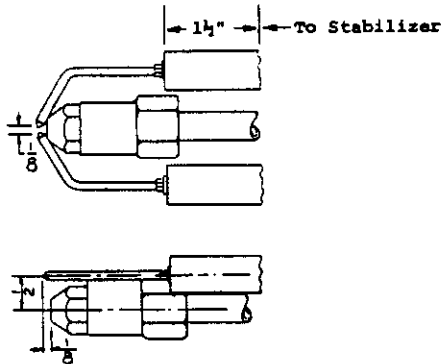

Gun Assembly Adjustment. The gun assembly can be adjusted in the slot inside of fan housing by loosening screw holding slot cover in position. Nozzle tip should ordinarily be located 5/16 inch behind the front face of the cone.

Removing Gun Assembly. Disconnect the oil line at the fan housing and remove lock nuts on copper tube fitting. Remove transformer hold down screw in upper left hand corner and loosen hold down clip in upper right hand corner, then swing transformer up and forward. Gun assembly can now be removed through this opening.

VENTILATION

An oil furnace must have a generous supply of fresh air available to support combustion. A furnace which is installed in a confined space must be provided with two permanent openings in the enclosure, one six inches from the top of the enclosure and one six inches from the bottom. Each opening shall have a free area of not less than one square inch per 1,000 Btu input of the total input of all appliances within the enclosure. The openings shall be freely communicating with the interior areas having in turn adequate infiltration from the outside.

THE FLOW OF COMBUSTION AND VENTILATING AIR MUST NOT BE OBSTRUCTED FROM REACHING THE FURNACE.

VENTING

The flue pipe to the chimney must be the same size as the flue outlet of the furnace, have no reductions, be of a corrosion-resistant material, and have an upward pitch of 1/4 inch for every foot of horizontal run. A barometric damper of adequate size must be installed in the flue pipe observing the instructions packaged with the damper control. The barometric damper opening must be located in the same atmospheric pressure zone as the combustion air inlet to the furnace.

THERMOSTAT

These furnaces are designed to be controlled with any 24V heating or heating/cooling thermostat. The heat/cool thermostats must be designed for independent heat/cool transformer circuits to assure that the 24V transformer built into the oil primary control does not conflict with the air conditioner 24V transformer. The heat anticipator should be set at 0.40A. See additional information and wiring details on pages 4 and 7.

FAN AND LIMIT CONTROL

The fan and limit control is factory installed on all the units except the knocked down units. Set the fan control to come on at 130-135° and off at 115 or 120°. These settings may have to be varied due to the static pressure imposed upon the system. On counterflow furnaces the differential may have to be greater to prevent blower cycling on shut down. The limit setting should be observed and be set in accordance with the table below.

When the installation is completed, measure the air temperature in the discharge plenum and return air plenum. The temperature rise across the unit should fall within the "Rise Range" as shown on the table below. It is normally desirable to operate in the middle of the range unless air conditioning or other installation requirements make that unfeasible. The speed of the blower may have to be either increased or decreased to obtain this temperature. The blower motor is equipped with a variable speed pulley to make these adjustments. If the speed of the blower is changed, the belt tension will also have to be changed. This is done by the motor adjusting bracket by screwing it up or down as the case may be. When adjusted properly, you should be able to depress the belt one inch. Too tight a belt will cause bearing wear. Too loose a belt will cause slippage. On knocked down units be sure belts and pulleys are properly aligned.

An additional control called the upper limit control is installed in the blower compartment on counterflow models. The function of this control is to shut off the burner if the temperature in the upper part of the furnace exceeds the factory setting of the control. Should the control stop the burner (high temperature) it will again complete the circuit when cool. This control is wired in series with the limit side of the fan and limit control located in the burner compartment.

The fan and limit control in the burner compartment governs the blower operation, by means of two temperature selections. One lever is set at 125° for example, to start the blower, and the other lever is at a lower temperature, 110° to stop the blower. These settings may be varied to suit the homeowner's comfort. A greater temperature difference between settings may result in less repetition of the blower operation at the end of the heating cycle. A low "off" temperature is recommended for longer blower operation as this keeps the air of the home in more constant circulation.

NOTE: Do not set the blower on setpoint lever of the combination fan/limit control above 150.

TEMPERATURE RISE RANGES AND LIMIT CONTROL SETTINGS °F		
Model	Rise Range	Limit Control Setting
F81 F97	60 - 100 70 - 100	200 200
F120L NB120	60 - 100 60 - 90	200 190
C1 C2	60 - 100 70 - 100	230 250
F86H F120H	60 - 90 70 - 90	190 190
F86CF F100CF	60 - 100 70 - 110	210 210

MAINTENANCE

LUBRICATION

Blower, blower motor and oil burner motor bearings should be lubricated before starting and at least twice each year using a few drops of a good grade of SAE-20 motor oil. Some blowers have no oil cups and are equipped with permanently lubricated phosphor bronze bearings and need no oiling.

INSPECT AIR FILTER

Renew filters before each heating season begins. It is recommended that filters also be changed at least twice during the heating season.

Be sure the new filters are set securely in the filter rack so there can be no leakage around them. (See instructions on inside of blower compartment door).

FINAL INSPECTION AND TEST

Final inspection and test of an installation shall be made to determine that the work has been done in full accordance with regulations and according to the highest standards for safety, performance and appearance. Such an inspection and test should indicate the following, as a minimum:

1. Determine that all parts of the oil storage and circulating system, including tank, piping and burner, are free from oil leaks. Be sure that no oil discharges from the nozzle when burner is not operating.
2. Be sure that the suction line and pump have been entirely vented of air so that the burner has instantaneous oil shutoff at the nozzle and so that the pump operates without an air noise.
3. Check the flame adjustment to determine that the flame is clear, quiet, free of odor and oil nozzle is of proper size for the furnace.
4. Test operation of burner by operating the thermostat. First, set the thermostat above room temperature. Burner should start. Second, set thermostat below room temperature. Burner will stop.
5. Check operation of burner primary control in accordance with manufacturers' instructions included with the control. Following is the method we recommend in checking the safety switch in this primary control.
 - (a) Flame Failure - simulate by shutting off oil supply manual valve, while burner is on. After 45 seconds the safety switch locks out, ignition stops, motor stops and the oil valve closes. This condition requires resetting the safety switch.
 - (b) Ignition Failure - test by closing oil supply while burner is off. Run through starting procedure, omitting step 3. The safety switch locks out as in flame failure.
 - (c) Power Failure - turn off power supply while burner is on. When burner goes out, restore power and burner will restart.
 - (d) If operation is not as described, check wiring and installation first. If trouble appears to be in the control circuit, replace the flame detector. If trouble still persists, replace the burner mounted relay.

RETURN AIR

The return air to the furnace must be conducted from a source outside the utility room, closet, or furnace room to prevent chimney down draft. Also remember air openings in casing front, return air grilles, and warm air registers must not be obstructed.

SERVICE HINTS

"Preventive maintenance" is the best way to avoid unnecessary expense, inconvenience, and retain operating efficiency of your furnace. It is advisable to have your heating system and burner inspected at periodic intervals by a qualified serviceman. If trouble develops, follow these simple checks before calling the serviceman.

1. Make sure there is oil in tank and valve is open.
2. Make sure thermostat is set above room temperature.
3. Make sure electrical supply to furnace is on and fuses are not blown or circuit breakers tripped.
4. Reset safety switch of burner primary control.
5. Press thermal protector button of burner motor.
6. If burner runs but there is no flame, the fuel pump may be airbound. Follow instructions for bleeding fuel pump.

COMMON CAUSES OF TROUBLE

CAUTION: To avoid accidents, always open main switch (OFF position) when servicing burner.

BURNER WILL NOT PRODUCE FLAME. Check oil level gauge to see that there is sufficient oil in tank or tanks. Check the burner mounted relay control. **DO NOT ADJUST THIS CONTROL.**

Check position of electrodes; incorrect position will cause slow or delayed ignition. Clean electrodes and nozzle. Check and clean strainer in pump. If oil line filter is used, check filter condition.

BURNER STARTS OR STOPS TOO OFTEN. Limit control may be set too low. Check heat anticipator setting on thermostat.

NOZZLE PRODUCES A STRINGY FLAME. Worn tangential grooves in nozzle. Replace nozzle.

BASEMENT TANK HUM. Occasionally with a two-pipe installation there may be a low return line hum. Eliminate hum by installing a special anti-hum valve in the return line near pump.

HEAVY FIRE OR PULSATING FLAME may occur after burner starts. It may be caused by a slight oil leak in the fuel pump and cannot be corrected except by replacing the pump. This happens only when the burner is started.

CHATTERING SOUND OR HIGH PITCH NOISE from motor can usually be traced to where a conduit or BX cable is fixed rigidly or attached to some part of the building. Relieving this strain may eliminate noise.

PUMP SQUEALS OR CHATTERS. This may be caused by air in pipes. Check all joints in the oil supply pipe for leaks. Check strainer in pump; if dirty, clean.

INSUFFICIENT HEAT. Check limit control setting. It may be that flame is not allowed to stay on long enough to generate sufficient heat in furnace to heat the house properly. If the proper size furnace has been selected according to house requirements and satisfactory heat is not obtained, recheck the heating plant for size and capacity in relation to house. Check for clogged filters.

CARE OF FINISH

Your unit is painted with baked enamel. Like a good piece of furniture it has an excellent appearance and an occasional waxing and dusting will keep it attractive for years.

CLEANING OF FURNACE

All units have one or more clean out plugs for easy cleaning of the heat exchanger. They are accessible either from the front or back on some units and the sides on other units. The furnace should be checked periodically to see if it needs cleaning.

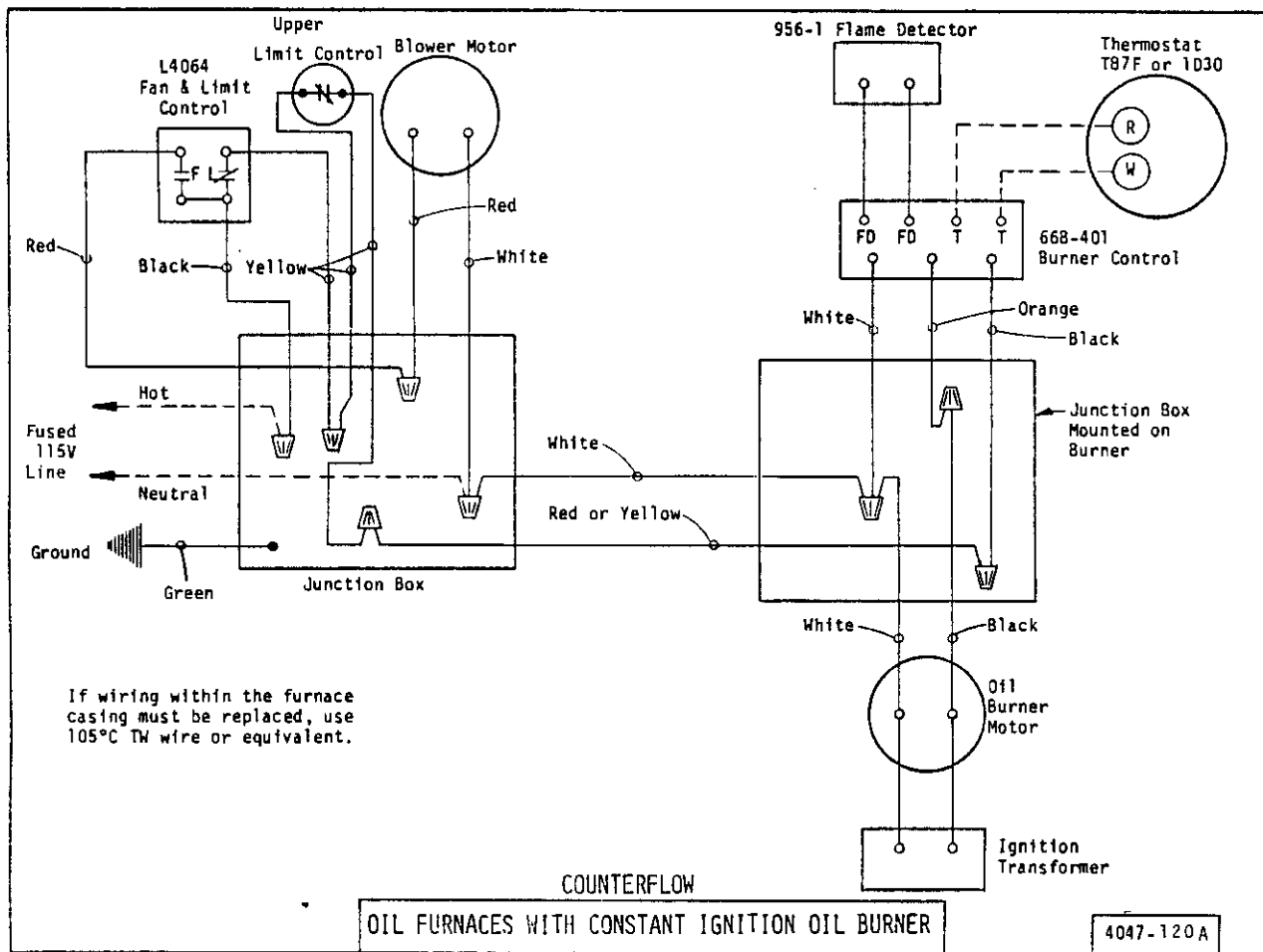
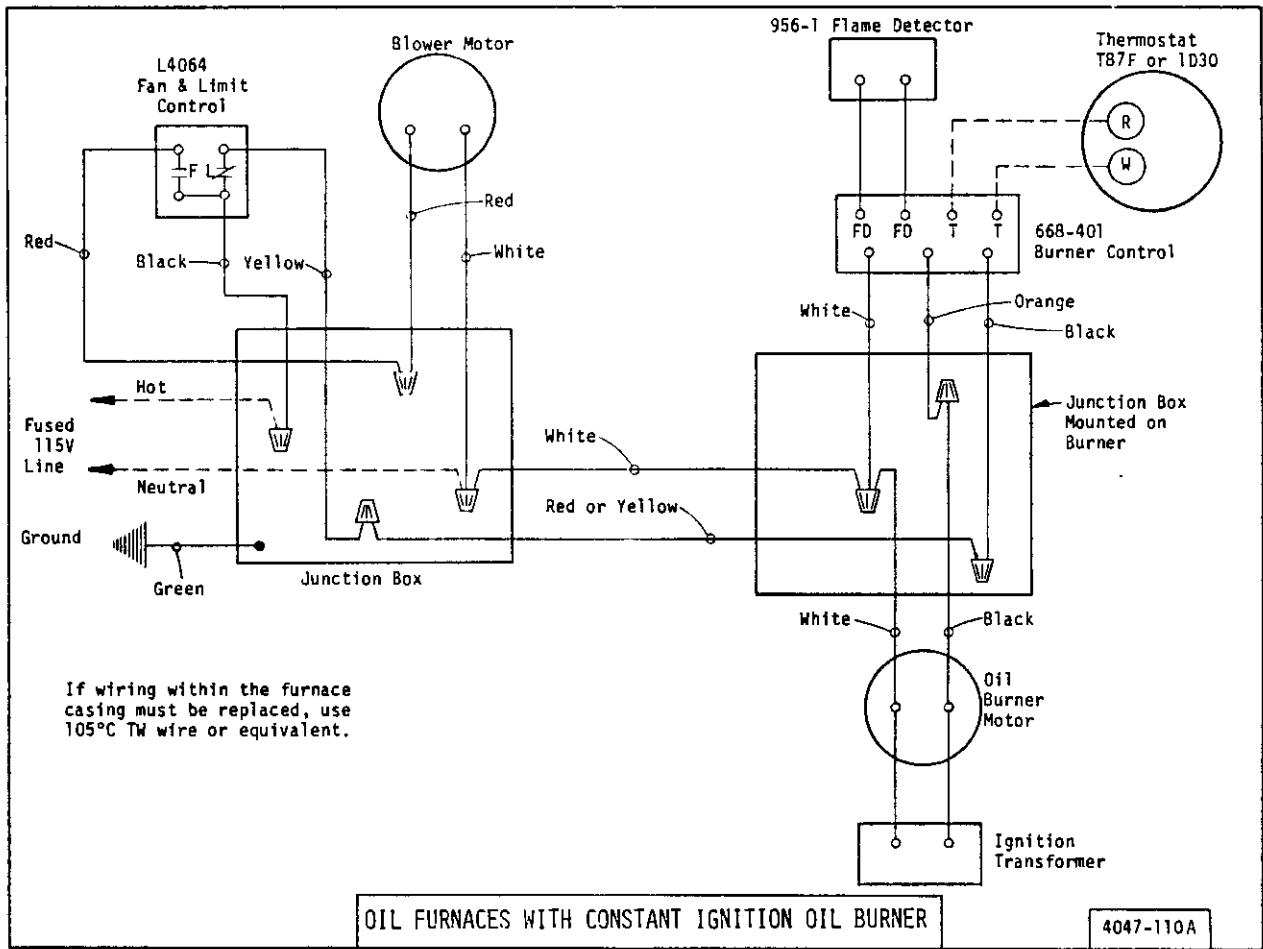

A-7000 SINGLE STAGE AND B-8000 TWO STAGE FUEL UNITS

MODELS A2 & B2 FOR 3450 RPM, WHITE LABEL

MODEL B TWO STAGE FUEL UNIT HAS SAME PORTING ARRANGEMENT AS MODEL A

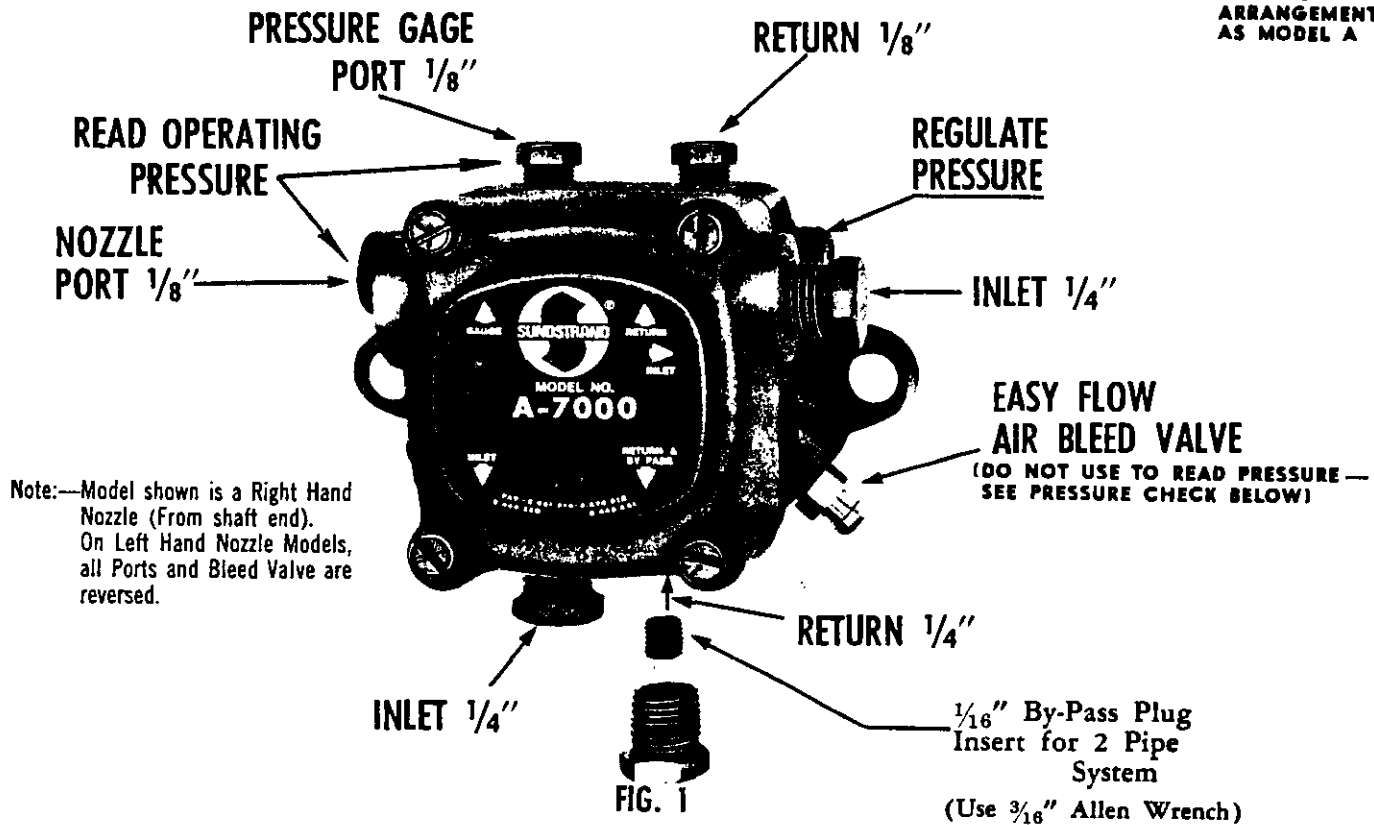

ONE-PIPE SYSTEM

Connect inlet line to pump inlet. Start burner. Arrange primary burner control for continuous operation during purging. Open easy flow bleed valve 1/2 turn CCW and start burner. Bleed unit until all air bubbles disappear—**HURRIED BLEEDING WILL IMPAIR EFFICIENT OPERATION OF UNIT.** Tighten easy flow bleed valve securely.

TWO-PIPE SYSTEM

Remove 1/16" plug from plastic bag attached to unit. Remove 1/4" plug from return port. Insert by pass plug (See Figure 1). Attach return and inlet lines.

Start burner—Air bleeding is automatic. Opening Easy Flow Air Bleed Valve will allow a faster bleed if desired.

Return line must run to within 3" of the bottom of the tank (See Figure 3). Failure to do this may introduce air into the system and could result in loss of prime.

CAUTION

Pressurized or gravity feed installations must not exceed 10 P.S.I. on inlet line or return line at the pump. A pressure greater than 10 P.S.I. may cause damage to the shaft seal.

PRESSURE CHECK

If a pressure check is made, use GAGE PORT OR NOZZLE PORT. DO NOT USE EASY FLOW BLEED VALVE PORT. The Easy Flow Bleed Valve Port contains pressure higher than operating pressure. Setting pump pressure with gage in the Easy Flow Bleed Valve Port results in WRONG operating pressure.

ALL SYSTEMS

IMPORTANT INFORMATION

Long or oversized inlet lines may require the pump to operate dry during initial bleeding period. In such cases, the priming may be assisted by injecting fuel oil into the pump gearset.

Under lift conditions, oil lines and fittings must be air tight. To assure this, "Pipe Dope" may be applied to both the used and unused inlet and both return fittings.

MOUNTING POSITION

Model "A" Single Stage Fuel Unit may be mounted in any position.

Model "B" Two Stage Fuel Unit may be mounted in any position except upside down (1/8" ports pointed down).

VACUUM CHECK

A Vacuum Gage may be installed in either of the 1/4" inlet ports or in the 1/8" return port (on single pipe installations), whichever is most convenient. The Model "A" pump should be used where the vacuum does not exceed 10" hg, vacuum and the Model "B" pump used where vacuum does not exceed 20" hg, vacuum.

ONE-PIPE SYSTEM (Model A)

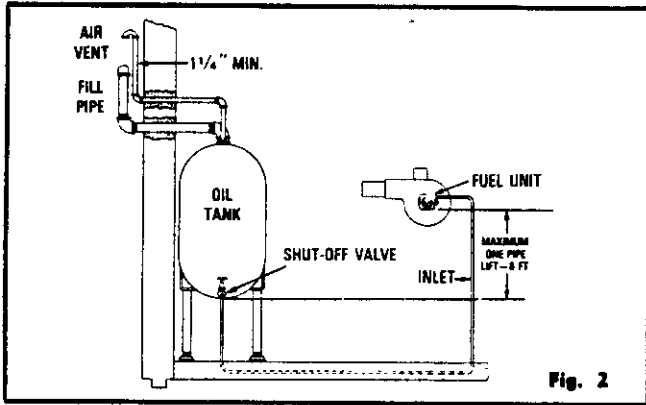

The SUNDSTRAND MODEL "A"-70 FUEL UNIT may be installed ONE-PIPE with Gravity Feed or Lift.

The maximum allowable lift is 8 ft.—See Figure 2.

IMPORTANT: One-pipe installations must be absolutely air tight or leaks or loss of prime may result. Bleed line and fuel unit completely. Bleed for 15 seconds after last air is seen from easy flow to be certain lines are air free.

TWO-PIPE SYSTEM (Model A and B)

A SINGLE STAGE

Lift "L" Fig 3	1725 RPM		3450 RPM	
	3/8" OD Tubing	1/2" OD Tubing	3/8" OD Tubing	1/2" OD Tubing
0'	65'	100'	53'	100'
1'	60'	100'	49'	100'
2'	54'	100'	45'	100'
3'	50'	100'	41'	100'
4'	45'	100'	37'	100'
5'	40'	100'	33'	100'
6'	35'	100'	29'	100'
7'	30'	100'	25'	99'
8'	25'	100'	21'	83'
9'	20'	83'	17'	68'
10'	16'	64'	13'	52'

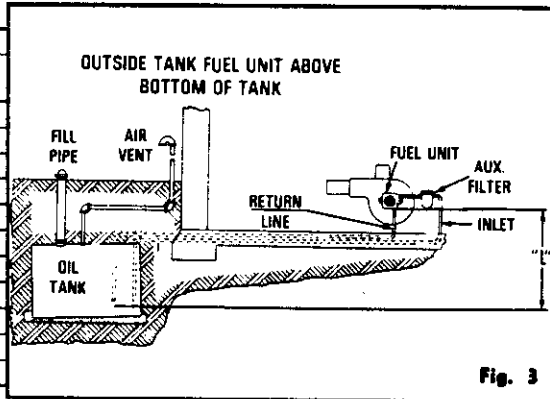

B TWO STAGE

Lift "L" Fig 3	1725 RPM		3450 RPM	
	3/8" OD Tubing	1/2" OD Tubing	3/8" OD Tubing	1/2" OD Tubing
0'	100'	100'	68'	100'
2'	92'	100'	63'	100'
4'	85'	100'	58'	100'
6'	78'	100'	53'	100'
8'	70'	100'	48'	100'
10'	63'	100'	42'	100'
12'	56'	100'	37'	100'
14'	48'	100'	32'	100'
16'	40'	100'	27'	100'
18'	33'	100'	22'	88'

ALWAYS TERMINATE RETURN LINE AS SHOWN IN FIG. 3
LINE LENGTHS INCLUDE BOTH VERTICAL & HORIZONTAL LENGTHS

PART NO. 8400-001
CONSTANT IGNITION - NON RECYCLING
OIL BURNER PRIMARY CONTROL
WITH 8400-002 FLAME DETECTOR

The Oil Burner Primary Control provides safe operation of oil burners on heating plants where ignition during the entire burner cycle is desired.

The Oil Burner Primary (Part No. 8400-001) is used with Flame Detector (Part No. 8400-002).

SPECIFICATIONS

Room Thermostat: Set dial of adjustable heater on .4. For fixed anticipation thermostats, use .35 to .45 amp heater.

Safety Timing: For Part No. 8400-001: 45 seconds.

INSTALLATION

The proper **LOCATION** and **MOUNTING** of the primary oil burner control panel on the burner and the flame detector with respect to the oil flame shall be determined by the furnace, boiler, or burner manufacturer.

WIRING

If this control, supplied as part of a furnace, boiler or burner, is wired to the equipment or if the manufacturer of such equipment provides instructions for wiring this control, then follow his recommendations. If no special wiring instructions are given, then follow the electrical connections shown on this diagram for a simple system.

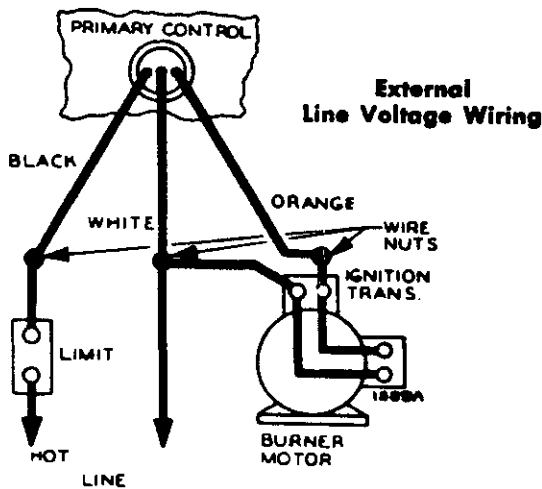

Low Voltage Wiring

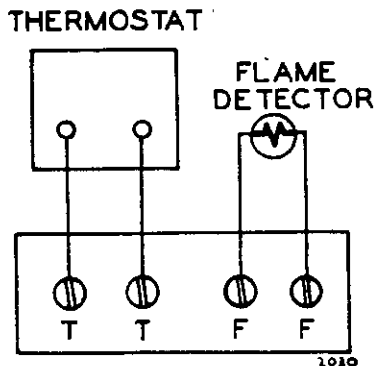

TESTING

The following control checks should be made after each installation to insure that the controls are correctly wired and functioning properly.

1. Open the main line switch.
2. Adjust thermostat or operating control to call for heat.
3. Operate the manual reset button on top of control.
4. Make certain that high limit control is set at the correct temperature.
5. Open the hand valve in the oil line. The system is now ready for the following tests.

A. NORMAL CYCLE

Close the line switch. The burner should start and continue to run normally. If burner starts, establishing flame, but then locks out on safety, make "Flame Detector Check" at this time.

B. SAFETY TIMING

1. Let the burner run for about 5 minutes. Then remove one of Flame Detector leads from the "F" terminals. After a time period corresponding to the safety timing has elapsed, the control should lock out on safety, stopping the burner.
2. Open the line switch.
3. Replace Flame Detector lead removed in step 1.
4. Wait about 3 minutes. Then operate the manual reset button on top of control.

C. HIGH LIMIT AND THERMOSTAT CHECK

1. Close the line switch to start the burner.
2. Lower the setting of the high limit control to its lowest setting. This should stop the burner, unless furnace or boiler temperature is below the minimum setting of the high limit.
3. Return high limit control to its proper setting. Burner should restart.
4. With the burner running, turn thermostat to its lowest setting. This should stop the burner, unless actual room temperature is below the lowest setting of the thermostat. (Note: On systems supplying domestic hot water, burner will continue to run if low limit control is not satisfied).
5. Return thermostat to its proper setting.

D. FLAME DETECTOR CHECK (This test is not required if the control performs as described in test A).

If the burner starts but the control locks out (stopping the burner), check the flame detector as follows:

1. Open the line switch.
2. Connect one end of a wire jumper to one of the "F" terminals.
3. Start the burner by closing the line switch. As soon as flame has been established, connect other end of the wire jumper to the other "F" terminal. **WARNING:** The control provides no safety protection with this jumper installed. **DO NOT** leave burner in this condition except for making this check.

D. FLAME DETECTOR CHECK (continued)

If the control still locks out with the jumper installed, the control should be replaced. If the control does not lock out, however, check the operation of the flame detector as follows:

Possible Cause of Trouble	Correction
Open circuit in cell	Replace Cell (Cell Assembly of Flame Detector. Do not disturb position of bracket or socket assembly .
Flame detector improperly positioned	Locate flame detector according to the burner manufacturer's specifications .

FLAME DETECTORS

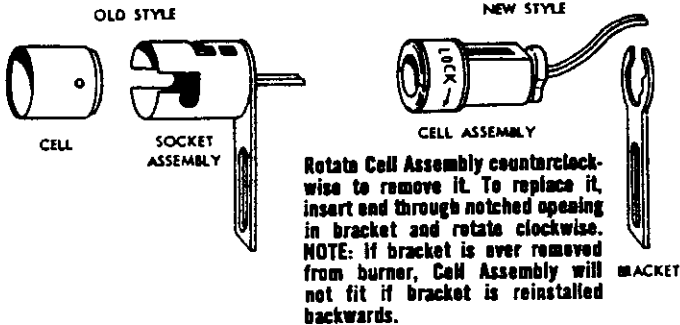

4. If safety lockout problem is of an intermittent nature (only lockouts occasionally), the following additional check may be made to insure that flame detector location is not a marginal one:

- (a) Disconnect flame detector leads from "F" terminals.
- (b) Attach a jumper wire to one "F" terminal. Start burner. Then immediately connect jumper wire to the other "F" terminal. Burner should continue to run.
- (c) With burner running, attach flame detector leads to an accurate ohmmeter. Reading of ohmmeter should be below 1000 ohms, and preferably as low as 500 ohms.

NOTE: If indicator of ohmmeter remains steady, readings up to 2000 ohms should also be acceptable. Generally, though the lower the reading, the better the application, and less likely the change of a variation in the burner flame causing a safety lockout.

- (d) If resistance of flame detector is over 1000 ohms, it may not be able to see the burner flame properly. Check alignment of the flame detector through the hole in the static pressure disc. Clean this hole if it is blocked by foreign matter. Check for broken "F" wires.
- (e) If flame detector alignment is good but resistance is still high, readjustment of burner flame and/or nozzle replacement may be necessary (according to burner manufacturer's instructions).
- (f) **WARNING:** Be sure to remove wire jumper after finishing this flame detector check.

OIL BURNER SPECIFICATIONS

Furnace Model	Wayne Burner			U.L. Burner Rating No.	Air Cone Type	Static Disc Inches O.D.	Burner Primary Control	Flame Detector	Nozzle	
	MSR	Spec. No.	Bard No.						GPH	Bard No.
F81	8"	129-29	9020-009	TS-1	1A	3-11/16	668-401	956-0106	.75	9011-001
F86H	8"	129-29	9020-009	TS-1	1A	3-11/16	668-401	956-0106	.75	9011-001
F86CF	8"	129-29	9020-009	TS-1	1A	3-11/16	668-401	956-0106	.75	9011-001
F97	6"	129-31	9020-010	TS-1	1A	3-11/16	668-401	956-0106	.85	9011-002
F100CF	6"	129-31	9020-010	TS-1	1A	3-11/16	668-401	956-0106	.85	9011-002
F120L	8"	129-33	9020-011	TS-2	2A	3	668-401	956-0106	1.10	9011-004
F120H	8"	129-33	9020-011	TS-2	2A	3	668-401	956-0106	1.10	9011-004
NB120	6"	129-37	9020-012	TS-2	2A	3	668-401	956-0106	1.10	9011-004
C1	6"	129-37	9020-012	TS-2	2A	3	668-401	956-0106	1.25	9011-006
C2	6"	129-35	9020-013	TS-3	3A	2	668-401	956-0106	1.65	9011-009

Bard No. 8400-001.

Bard No. 8400-002.

PARTS LIST
OIL FURNACES

PART NO.	DESCRIPTION	F81	F97	NB120	C1	C2	F86CF	F100CF	F86H	F120H	F120L	
5153-012	Bearings 3/4"	x	x	x			x	x	x	x	x	
5153-013	Bearings 1"				x	x						
5601-007	Belt 42"	x										
5601-001	Belt 36"								x		x	
5601-003	Belt 38"			x								
5601-009	Belt 46"				x	x						
5601-005	Belt 40"		x				x	x				
5601-002	Belt 37"									x		
5153-018	Collar 3/4"	x	x	x			x	x	x	x	x	
5153-021	Collar 1"				x	x						
7090-005	Combustion Chamber	x	x				x	x	x			
7090-003	Combustion Chamber			x						x	x	
7090-006	Combustion Chamber				x	x						
5153-014	Cushion - Bearing	x	x	x			x	x	x	x	x	
5153-015	Cushion - Bearing				x	x						
8402-007	Fan and Limit 8"						x	x				
8402-001	Fan and Limit 11"	x	x		x	x					x	
8402-003	Fan and Limit L4064B								x			
8402-005	Fan and Limit L4064C			x						x		
7004-012	Filter 20x20	x		(2)						x		
7004-013	Filter 20x25		x									
7004-011	Filter 16x25				(2)				x		(2)	
7004-001	Filter 10x20						(2)					
7004-003	Filter 12x20							(2)				
7003-004	Filter 16x25 P					(2)						
7004-010	Filter 16x20									x		
1171-002	Handle - Door	x	x	x							x	
1171-003	Handle - Door	(2)	(3)	(2)	(4)	(4)	(2)	(2)	(2)		(2)	
9041-001	Heat Exchanger	x					x		x			
9041-022	Heat Exchanger		x									
9041-017	Heat Exchanger			x								
9041-018	Heat Exchanger				x							
9041-019	Heat Exchanger					x						
9041-021	Heat Exchanger							x				
9041-016	Heat Exchanger									x		
9041-003	Heat Exchanger										x	
*	Housing - Blower 10-10	x	x				x	x	x			
*	Housing - Blower 12-10			x						x	x	
*	Housing - Blower 140-14				x	x						

*Please order by model number.

**PARTS LIST
OIL FURNACES**

PART NO.	DESCRIPTION	F81	F97	NB120	C1	C2	F86CF	F100CF	F86H	F120H	F120L
8102-001	Motor 1/6 hp	x									
8104-002	Motor 1/4 hp		x				x	x	x		
8104-001	Motor 1/4 hp			x							
8105-001	Motor 1/3 hp				x	x					
8105-002	Motor 1/3 hp									x	x
8106-001	Motor 1/2 hp									x	
8200-014	Motor Adj. Kit	x	x	x	x	x	x	x	x	x	x
9011-001	Nozzle (.75 80° A)	x					x		x		
9011-002	Nozzle (.85 80° A)		x					x			
9011-004	Nozzle (1.10 80° A)			x						x	x
9011-006	Nozzle (1.25 80° A)				x						
9011-009	Nozzle (1.65 80° A)					x					
5501-013	Pulley-Blower 7 x 3/4	x		x							
5501-012	Pulley-Blower 6 x 3/4		x				x	x	x	x	x
5501-014	Pulley-Blower 8 x 1				x	x					
5501-015	Pulley-Motor 3-1/4 x 1/2	x	x	x	x	x	x	x	x	x	x
8400-001	Relay	x	x	x	x	x	x	x	x	x	x
8400-002	Sensor Cell	x	x	x	x	x	x	x	x	x	x
1912-001	Shaft-Blower 15-3/4 x 3/4	x	x	x			x	x	x	x	x
1912-006	Shaft-Blower 20x1				x	x					
8402-024	Upper Limit L180-4						x	x			
5153-002	Washer - Neoprene	x	x	x			x	x	x	x	x
5153-003	Washer - Neoprene				x	x					
5152-006	Wheel - Blower 10-10	x	x				x	x	x		
5152-022	Wheel - Blower 11-10			x						x	x
5152-025	Wheel - Blower 15-12 BD				x	x					
9020-010	MSR 6" Oil Burner		x					x			
9020-009	MSR 8" Oil Burner	x					x		x		
9020-012	MSR 6" Oil Burner			x	x						
9020-011	MSR 8" Oil Burner									x	x
9020-013	MSR 6" Oil Burner					x					
1921-010	Front Plate Gasket	x	x				x	x	x		
1921-012	Front Plate Gasket									x	x
1921-014	Front Plate Gasket			x							
1921-015	Front Plate Gasket				x						
1921-016	Front Plate Gasket					x					
1921-008	2" Dia. Clean-out Gasket	4	4	4	4	4	4	4	2	4	4
8620-007	Clean-out Plug Kit	4	4	4	4	4	4	4	2	4	4

Note: For oil burner parts, see oil burner parts list.
Minimum net billing \$15.00. Supersedes all previous lists.
Subject to change without notice.

*Denotes change.

MSR BURNER

Item Number	Description	9020-009 MSR 8"	9020-010 MSR 6"	9020-011 MSR 8"	9020-012 MSR 6"	9020-013 MSR 6"
1	Motor 1/8 hp - 3450 RPM	8101-003	8101-003	8101-003	8101-003	8101-003
2	Screw	9021-085	9021-085	9021-085	9021-085	9021-085
3	Motor Cord Cover	9021-078	9021-078	9021-078	9021-078	9021-078
4	Transformer	8407-030	8407-030	8407-030	8407-030	8407-030
5	Screw	9021-081	9021-081	9021-081	9021-081	9021-081
6	Fan	9021-006	9021-006	9021-006	9021-006	9021-006
7	Trans. Clip Screw	9021-084	9021-084	9021-084	9021-084	9021-084
8	Trans. Clip	9021-008	9021-008	9021-008	9021-008	9021-008
9	Fan Housing	9021-010	9021-010	9021-010	9021-010	9021-010
10	Oil Line Slot Cover	9021-015	9021-015	9021-015	9021-015	9021-015
11	Oil Line Locknut	9021-080	9021-080	9021-080	9021-080	9021-080
12	Inner Air Adjusting Band	9021-012	9021-012	9021-012	9021-012	9021-012
13	Outer Air Adjusting Band	9021-014	9021-014	9021-014	9021-014	9021-014
14	Oil Line Elbow	9021-018	9021-018	9021-018	9021-018	9021-018
15	Coupling	9021-017	9021-017	9021-017	9021-017	9021-017
16	Fuel Unit	9021-003	9021-003	9021-003	9021-003	9021-003
17	Oil Line Elbow	9021-019	9021-019	9021-019	9021-019	9021-019
18	Oil Pipe	9021-024	9021-024	9021-024	9021-024	9021-024
19	Buss Bar	9021-032	9021-033	9021-032	9021-033	9021-033
20	Electrode Support Screw	9021-079	9021-079	9021-079	9021-079	9021-079
21	Electrode Support	9021-035	9021-035	9021-035	9021-035	9021-035
22	Baffle Plate Δ	9021-040	9021-040	9021-040	9021-040	9021-040
23	Baffle Plate Screw	9021-076	9021-076	9021-076	9021-076	9021-076
24	Insulator	9021-044	9021-044	9021-044	9021-044	9021-044
25	Electrode Stem	9021-046	9021-046	9021-046	9021-046	9021-046
26	Nozzle Adapter	9021-043	9021-043	9021-043	9021-043	9021-043
27	Insulator Bushing	9021-034	9021-034	9021-034	9021-034	9021-034
28	Pinnut	9021-075	9021-075	9021-075	9021-075	9021-075
29	Oil Line Fitting	9021-020	9021-020	9021-020	9021-020	9021-020
30	Air Cone Screw	9021-053	9021-053	9021-053	9021-053	9021-053
31	Flange Mounting Screw	9021-060	9021-060	9021-060	9021-060	9021-060
32	Gasket	9021-073	9021-073	9021-073	9021-073	9021-073
33	Mounting Flange	9021-059	9021-059	9021-059	9021-059	9021-059
34	Air Cone	9021-056	9021-056	9021-056	9021-056	9021-056
35	Air Tube	9021-051	9021-050	9021-051	9021-050	9021-050
	Gun Assy. Δ (Items 18 thru 29)	9021-066	9021-067	9021-066	9021-067	9021-067

Δ Break baffle plate to 3" dia. on 9020-011 and 9020-012 burners.
Break baffle plate to 2" dia. on 9020-013 burner.

