



**OIL FURNACE  
INSTALLATION INSTRUCTIONS**

**BARD MANUFACTURING COMPANY, BRYAN, OHIO 43506**

**MANUAL 2100-015A**

**INSTALLATION AND OPERATING INSTRUCTIONS  
FOR OIL FURNACES**

**LOCATION**

Locate the furnace as close to the chimney as practical giving consideration to the accessibility of the oil burner, controls, and blower for service. Allow a minimum of 24 inches at front of furnace for servicing oil burner. Allow enough room at the rear of the furnace to change filters and remove the blower. Clearances from combustible material as stated on the furnace must be maintained. If close clearances are not stated, use U.L. recommended standard clearance or clearances permitted by local codes. For basement installation, a raised concrete pad is recommended. This will keep the bottom of the furnace dry and reduce rusting.

On knocked down units, assemble according to the installation instructions packed with the unit.

If the unit is to be installed on combustible material, a non-combustible base must be used with this unit. Please refer to U.L. label on unit for side, top, back, and flue pipe clearances from combustible material.

**WIRING**

All units are factory wired with the exception of the unassembled or knocked down units. All wiring must conform to the National Electrical Code and all local codes. A separate fuse or breaker should be used for the furnace. If replacement wire is necessary, use 105°C, 16 gauge wire.

**OIL LINE PIPING**

First determine whether the pipe system is to be a single line system or a two line system. After determining the best piping system for the application, refer to the pump specifications on page 6. All connections must be absolutely air tight or you will have a malfunction of the burner. When installing the piping a good oil filter should be installed close to the burner. A single line system is recommended for gravity feed.

**OIL BURNER**

Most units are shipped with the oil burner installed. Inspect firepot refractory before firing to be sure it has not been jarred out of position in shipment. Burner air tube must not extend beyond inside surface of firepot, preferable location is 1/8 inch from inside surface.

**BURNER ADJUSTMENT**

Removing Gun Assembly. Disconnect the oil line at the fan housing and remove lock nut on copper tube fitting. Remove transformer hold-down screw in upper left-hand corner and swing transformer to left of hinge clips. Gun Assembly can now be removed through this opening.

**BURNER NOZZLE**

Check nozzle size as to conformance to installation requirements. Install nozzle by screwing into hexagon adapter.

Nozzle Adapter: This burner is equipped with a dribble-proof nozzle adapter which will accomplish intended results only when installed with the stamped word "TOP" in the correct position.

Spacing of Electrodes: The electrodes should be spaced 1/8 inch apart. They should extend 1/8 inch beyond the end and 1/2 inch above the center of the nozzle tip as shown in the drawing below.

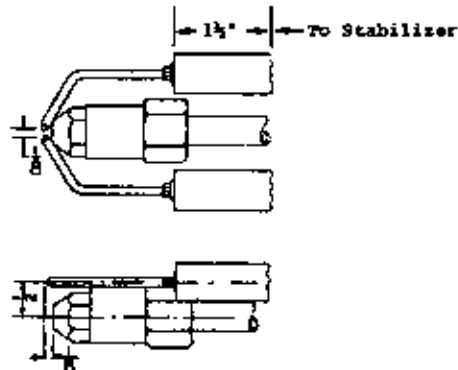

Gun Assembly Adjustment. The gun assembly can be adjusted in the slot inside of fan housing by loosening screw holding slot cover in position. Nozzle tip should ordinarily be located 5/8 inch behind the front face of the cone.

Air Adjustment. The air intake is located on the left side of the blower housing and consists of two interlocking bands. To adjust, loosen screw in outer band and position band by rotating to the desired opening. Retighten screw after adjustment to assure permanent adjustment.

Sufficient air should be introduced into the fire until a minus 1 smoke or trace of smoke is obtained. (Check with smoke tester). The screws should then be locked in position. After this has been set, check the top of the chimney on the outside. There should be a very slight haze, not smoke, coming out of the same. On a cold stack in extreme cold weather a white haze may come out of the chimney. This is due to the chilling of the gases and will correct itself as the chimney warms up. Any type of automatic fuel being burned in extreme cold weather will bring about the same chimney condition.

On unassembled or knocked down units where the burner is not installed, the air cone and baffle plate must be correctly matched with the firing rate, based upon the gallon per hour nozzle size.

Rating Gallons per Hour	Btu/h Input	Air Cone Bore	4-in-1 Disc Diameter
0.5 to 1.00	70,000 to 140,000	2-1/4"	3-3/8"
1.00 to 1.50	140,000 to 210,000	2-1/2"	2"
1.50 to 2.25	210,000 to 315,000	3"	2"
2.25 to 3.00	315,000 to 420,000	3"	No Disc

## FAN AND LIMIT CONTROL

The fan and limit control is factory installed on all units except the knocked down units. Set the fan control to come on at 130-135° and off at 115 or 120°. These settings may have to be varied due to the static pressure imposed upon the system. On counterflow furnaces the differential may have to be greater to prevent blower cycling on shut down. The limit side of the control is factory set and should not be changed.

When the installation is completed measure the air temperature in the discharge plenum and return air plenum. The temperature rise across the unit should be between 70 and 100 degrees, preferably 85 degrees. Operating at this temperature rise will eliminate cold spots which may cause condensation and rusting and possible over heating of the furnace. The speed of the blower may have to be either increased or decreased to obtain this temperature. The blower motor is equipped with a variable speed pulley to make these adjustments. If the speed of the blower is changed, the belt tension will also have to be changed. This is done by the motor adjusting bracket by screwing it up or down as the case may be. When adjusted properly, you should be able to depress the belt one inch. Too tight a belt will cause bearing wear. Too loose a belt will cause slippage. On knocked down units be sure belts and pulleys are properly aligned.

The controls for the counterflow models are located in the burner compartment and in the upper compartment or blower section. Their function, aside from governing the burner operation is to start and stop the blower at pre-selected temperature settings.

The control located in the blower compartment is a limit control. The function of this control is to shut off the burner if the temperature in the upper part of the furnace exceeds the factory setting of the control. Should the control stop the burner (high temperature) it will again complete the circuit when cool. This control is wired in series with the limit side of the fan and limit control located in the burner compartment.

The fan and limit control in the burner compartment governs the blower operation, by means of two temperature selections. One lever is set at 125° for example, to start the blower and the other lever is at a lower temperature, 110° to stop the blower. These settings may be varied to suit the homeowner's comfort. A greater temperature difference between settings may result in less repetition of the blower operation at the end of the heating cycle. A low "OFF" temperature is recommended for longer blower operation as this keeps the air of the home in more constant circulation.

The limit control setting may be from 175° to 200°. In mild weather a low limit setting is sometimes recommended.

**CAUTION: DO NOT SET THE BLOWER CONTROL ABOVE 150°.**

A setting above this temperature may cause the upper limit to function and it will have to cool and reset before the furnace will operate again.

All highboys and counterflows installed in a closet should have one square inch of free area per each 1000 Btu of input. These openings should be located six inches from the ceiling and six inches above floor for combustion. This may also apply to a tight basement or furnace room installation. Outside air must be introduced.

## TERMOSTAT

The thermostat furnished with the unit is either a Honeywell or White Rodgers. The heat anticipator on a thermostat must be set to match the amp draw of the relay. This is normally 4 amps. Failure to set the heat anticipator will cause either short or long burner cycles resulting in uneven heat.

## MAINTENANCE

### LUBRICATION

Blower, blower motor and oil burner motor bearings should be lubricated before starting and at least twice each year using a few drops of a good grade of SAE-20 motor oil. Some blowers have no oil cups and are equipped with permanently lubricated phosphor bronze bearings and need no oiling.

### INSPECT AIR FILTER

Renew filters before each heating season begins. It is recommended that filters also be changed at least twice during the heating season.

Be sure the new filters are set securely in the filter rack so there can be no leakage around them. (See instructions on inside of blower compartment door).

### FINAL INSPECTION AND TEST

Final inspection and test of an installation shall be made to determine that the work has been done in full accordance with regulations and according to the highest standards for safety, performance and appearance. Such an inspection and test should indicate the following, as a minimum:

1. Determine that all parts of the oil storage and circulating system, including tank, piping and burner, are free from oil leaks. Be sure that no oil discharges from the nozzle when burner is not operating.
2. Be sure that the suction line and pump have been entirely vented of air so that the burner has instantaneous oil shut-off at the nozzle and so that the pump operates without an air noise.
3. Check the flame adjustment to determine that the flame is clear, quiet, free of odor and oil nozzle is of proper size for the furnace.
4. Test operation of burner by operating the thermostat. First set thermostat above room temperature. Burner should start. Second set thermostat below room temperature. Burner will stop.
5. Check operation of burner primary control in accordance with manufacturers' instructions included with the control. Following is the method we recommend in checking the safety switch in this primary control.
  - a. Flame Failure - simulate by shutting off oil supply manual valve, while burner is on. After 45 seconds the safety switch locks out, ignition stops, motor stops and the oil valve closes. This condition requires resetting the safety switch.
  - b. Ignition Failure - test by closing oil supply while burner is off. Run through starting procedure, omitting Step 3. The safety switch locks out as in flame failure.
  - c. Power Failure - turn off power supply while burner is on. When burner goes out, restore power and burner will restart.
  - d. If operation is not as described, check wiring and installation first. If trouble appears to be in the control circuit, replace the flame detector. If trouble still persists, replace the burner mounted relay.

### RETURN AIR

The return air to the furnace must be conducted from a source outside the utility room, closet, or furnace room to prevent chimney down draft. Also remember air openings in casing front, return air grilles, and warm air registers must not be obstructed.

LO-BOW, HI-BOW, & HORIZONTAL  
OIL FURNACES

CONSTANT IGNITION OIL BURNER

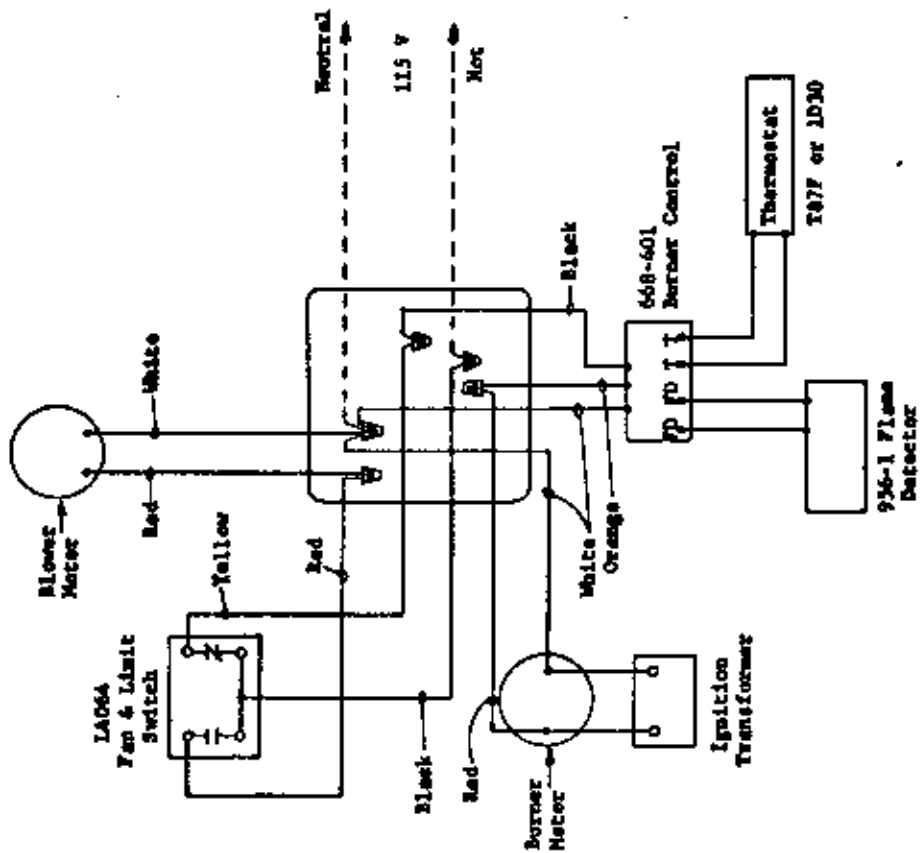

CONSTANTFLOW OIL FURNACES

CONSTANT IGNITION OIL BURNER

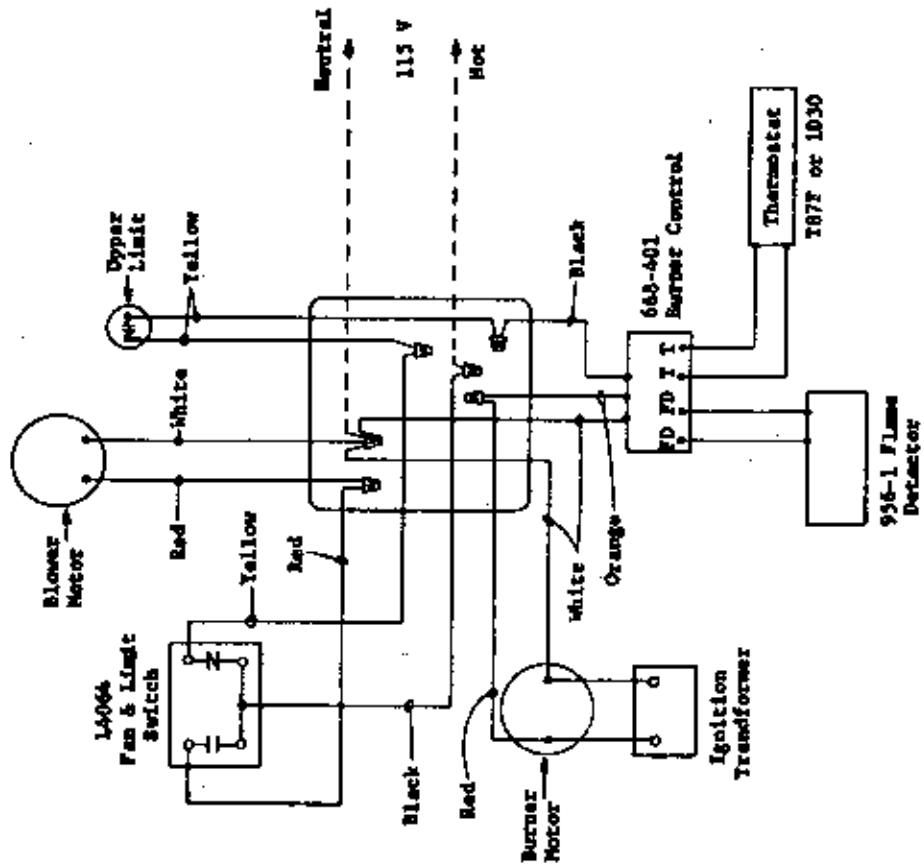

# INSTALLATION



# INFORMATION

FOR A-7000 SINGLE STAGE AND B-8000 TWO STAGE FUEL UNITS .  
MODELS A1 & B1 FOR 1725 RPM, BLACK LABEL  
MODELS A2 & B2 FOR 3450 RPM, WHITE LABEL

MODEL B TWO STAGE FUEL UNIT HAS SAME PORTING ARRANGEMENT AS MODEL A

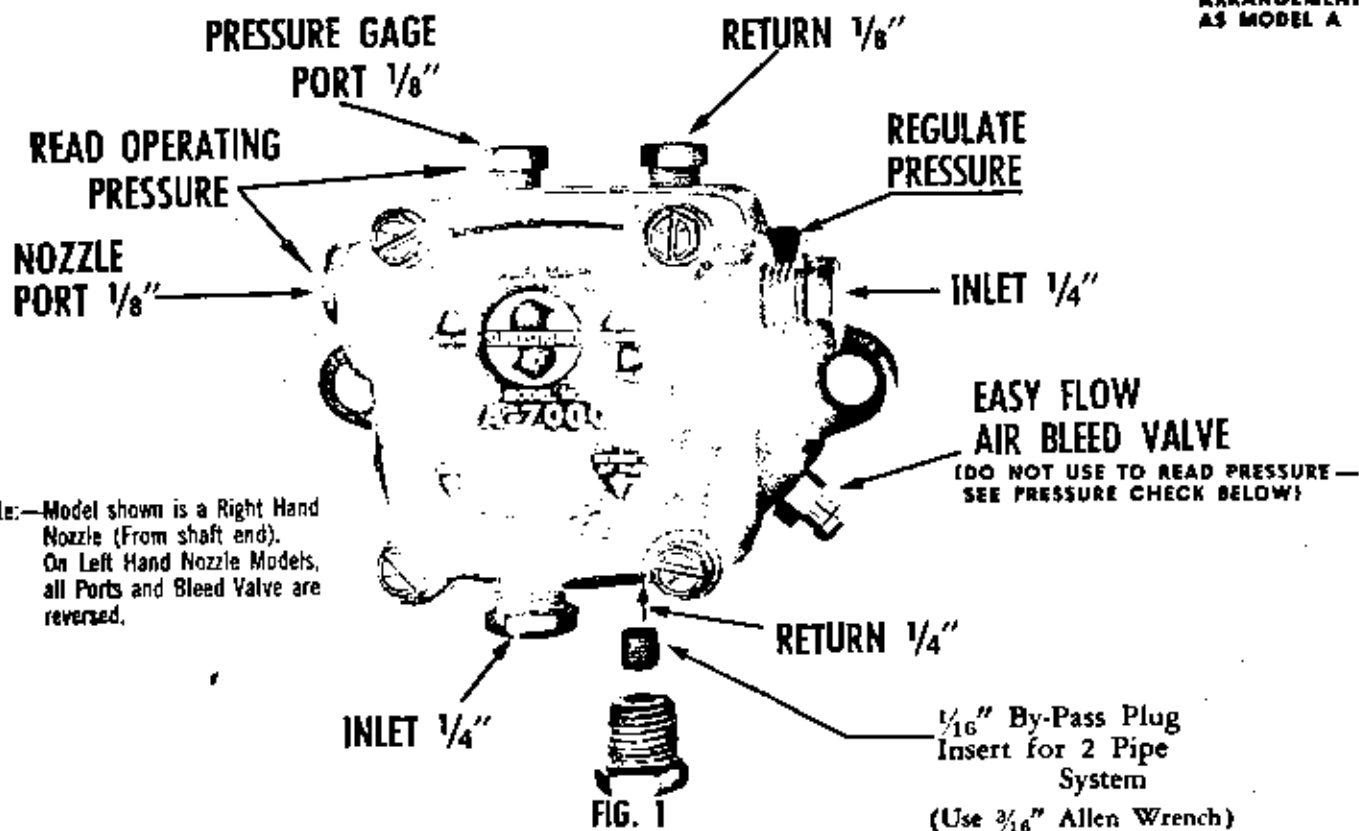

Note:—Model shown is a Right Hand Nozzle (From shaft end). On Left Hand Nozzle Models, all Ports and Bleed Valve are reversed.

## ONE-PIPE SYSTEM

Connect inlet line to pump inlet. Start burner. Arrange primary burner control for continuous operation during purging. Open easy flow bleed valve 1/2 turn CCW and start burner. Bleed unit until all air bubbles disappear—**HURRIED BLEEDING WILL IMPAIR EFFICIENT OPERATION OF UNIT.** Tighten easy flow bleed valve securely.

## TWO-PIPE SYSTEM

Remove 1/16" by pass plug from plastic bag attached to unit. Remove 1/4" plug from return port. Insert by pass plug (See Figure 1). Attach return and inlet lines. Start burner—Air bleeding is automatic. Opening Easy Flow Air Bleed Valve will allow a faster bleed if desired. Return line must run to within 3" of the bottom of the tank (See Figure 3). Failure to do this may introduce air into the system and could result in loss of prime.

## CAUTION

Pressurized or gravity feed installations must not exceed 10 P.S.I. on inlet line or return line at the pump. A pressure greater than 10 P.S.I. may cause damage to the shaft seal.

## ALL SYSTEMS

### IMPORTANT INFORMATION

Long or oversized inlet lines may require the pump to operate dry during initial bleeding period. In such cases, the priming may be assisted by injecting fuel oil into the pump gears. Under lift conditions, oil lines and fittings must be air tight. To assure this, "Pipe Dope" may be applied to both the used and unused inlet and both return fittings.

### MOUNTING POSITION

Model "A" Single Stage Fuel Unit may be mounted in any position.  
Model "B" Two Stage Fuel Unit may be mounted in any position except upside down (1/8" ports pointed down).

### PRESSURE CHECK

If a pressure check is made use GAGE PORT OR NOZZLE PORT. **DO NOT USE EASY FLOW BLEED VALVE PORT.** The Easy Flow Bleed Valve Port contains pressure higher than operating pressure. Setting pump pressure with gage in the Easy Flow Bleed Valve Port results in **WRONG** operating pressure.

### VACUUM CHECK

A Vacuum Gage may be installed in either of the 1/4" inlet ports or in the 1/8" return port (on single pipe installations), whichever is most convenient. The Model "A" pump should be used where the vacuum does not exceed 10" hg. vacuum and the Model "B" pump used where vacuum does not exceed 20" hg. vacuum.

# ONE-PIPE SYSTEM (Model A)

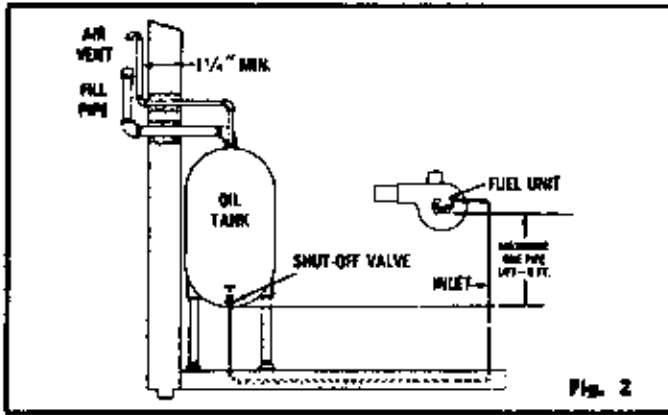

The SUNDSTRAND MODEL "A"-70 FUEL UNIT may be installed ONE-PIPE with Gravity Feed or Lift.

The maximum allowable lift is 8 ft.—See Figure 2.

**IMPORTANT:** One-pipe installations must be absolutely air tight or leaks or loss of prime may result. Bleed line and fuel unit completely. Bleed for 15 seconds after last air is seen from easy flow to be certain lines are air free.

# TWO-PIPE SYSTEM (Model A and B)

## A SINGLE STAGE

Lift "L" Fig 3	1725 RPM		3450 RPM	
	3/8" OD Tubing	1/2" OD Tubing	3/8" OD Tubing	1/2" OD Tubing
0'	65'	100'	53'	100'
1'	60'	100'	49'	100'
2'	54'	100'	45'	100'
3'	50'	100'	41'	100'
4'	43'	100'	37'	100'
5'	40'	100'	33'	100'
6'	35'	100'	29'	100'
7'	30'	100'	25'	99'
8'	25'	100'	21'	83'
9'	20'	83'	17'	68'
10'	16'	64'	13'	52'

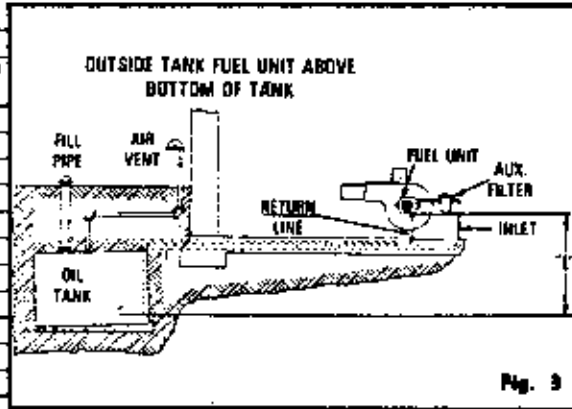

## B TWO STAGE

Lift "L" Fig 3	1725 RPM		3450 RPM	
	3/8" OD Tubing	1/2" OD Tubing	3/8" OD Tubing	1/2" OD Tubing
0'	100'	100'	68'	100'
2'	92'	100'	63'	100'
4'	85'	100'	58'	100'
6'	78'	100'	53'	100'
8'	70'	100'	48'	100'
10'	63'	100'	42'	100'
12'	56'	100'	37'	100'
14'	48'	100'	32'	100'
16'	40'	100'	27'	100'
18'	33'	100'	22'	88'

ALWAYS TERMINATE RETURN LINE AS SHOWN IN FIG. 3  
LINE LENGTHS INCLUDE BOTH VERTICAL & HORIZONTAL LENGTHS



# WHITE-RODGERS AUTOMATIC CONTROLS

## TYPE 668 Constant Ignition\* - Non Recycling OIL BURNER CONTROL With Series 956 Flame Detector

The type 668 Oil Burner Control provides safe operation of oil burners on heating plants where ignition during the entire burner cycle is desired.

The 668 is used with the 956 Flame Detector.

### SPECIFICATIONS

**Room Thermostat:** Set dial of adjustable heater on .4. For fixed anticipation thermostats, use .35 to .45 Amp. heater.

**Safety Timing:**

- For Types 668-401 to -499: 45 seconds
- For Types 668-501 to -599: 30 seconds
- For Types 668-601 to -699: 15 seconds

Underwriters Labs. Inc., refers to this as Intermittent Ignition. This ignition is "on" during the entire running part of the cycle.

### INSTALLATION

The proper Location and Mounting of the primary oil burner control panel on the burner and the flame detector with respect to the oil flame shall be determined by the furnace, boiler, or burner manufacturer.

### WIRING

If this control, supplied as part of a furnace, boiler or burner, is wired to the equipment or if the manufacturer of such equipment provides instructions for wiring this control, then follow his recommendations. If no special wiring instructions are given, then follow the electrical connections shown in this diagram for a simple system.

For more complicated systems, especially for hot water heating, consult the manufacturer of the heating plant or write to White-Rodgers giving full details of the desired sequence of control operation.

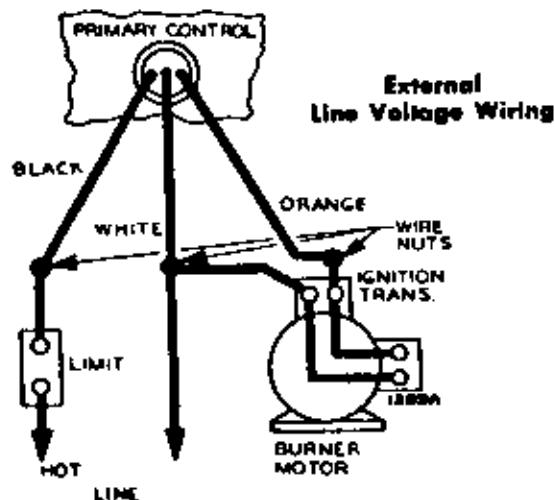

### Low Voltage Wiring

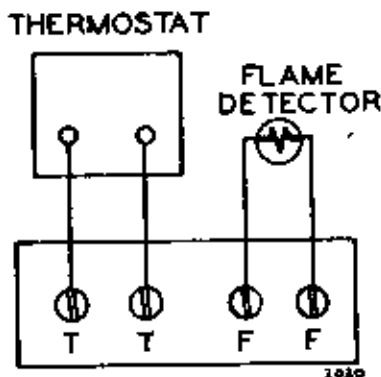

### TESTING

The following control checks should be made after each installation to insure that the controls are correctly wired and functioning properly.

1. Open the main line switch.
2. Adjust thermostat or operating control to call for heat.  
Operate the manual reset button on top of control.
4. Make certain that high limit control is set at the correct temperature.

5. Open the hand valve in the oil line. The system is now ready for the following tests.

**A. NORMAL CYCLE:**

Close the line switch. The burner should start and continue to run normally. (If burner starts, establishing flame, but then locks out on safety, make "Flame Detector Check" at this time.)

(TESTING CONTINUED ON NEXT PAGE)

## TESTING (Continued)

### B. SAFETY TIMING:

1. Let the burner run for about 5 minutes. Then remove one of Flame Detector leads from the "F" terminals. After a time period corresponding to the safety timing has elapsed, the control should lock out on safety, stopping the burner.
2. Open the line switch.
3. Replace Flame Detector lead removed in step 1.
4. Wait about 3 minutes. Then operate the manual reset button on top of control.

### C. HIGH LIMIT AND THERMOSTAT CHECK:

1. Close the line switch to start the burner.
2. Lower the setting of the high limit control to its lowest setting. This should stop the burner, unless furnace or boiler temperature is below the minimum setting of the high limit.
3. Return high limit control to its proper setting. Burner should restart.
4. With the burner running, turn thermostat to its lowest setting. This should stop the burner, unless actual room temperature is below the lowest setting of the thermostat. (Note: On systems supplying domestic hot water, burner will continue to run if low limit control is not satisfied.)
5. Return thermostat to its proper setting.

### D. FLAME DETECTOR CHECK: (This test is not required if the control performs as described in test A.)

If the burner starts but the control locks out (stopping the burner), check the flame detector as follows:

1. Open the line switch.
2. Connect one end of a wire jumper to one of the "F" terminals.
3. Start the burner by closing the line switch. As soon as flame has been established, connect other end of the wire jumper to the other "F" terminal. **WARNING:** The control provides no safety protection with this jumper installed. Do NOT leave burner in this condition except for making this check.

If the control still locks out with the jumper installed, the control should be replaced. If the control does not lock out, however, check the operation of the 956 flame detector as follows:

### D. FLAME DETECTOR CHECK (Continued):

Possible Cause of Trouble	Correction
Open circuit in Cell	Replace Cell (or Cell Assembly) of 956 Flame Detector. Do not disturb position of bracket or socket assembly.
Flame detector improperly positioned.	Locate flame detector according to the burner manufacturer's specifications.

#### TYPE 956 FLAME DETECTORS

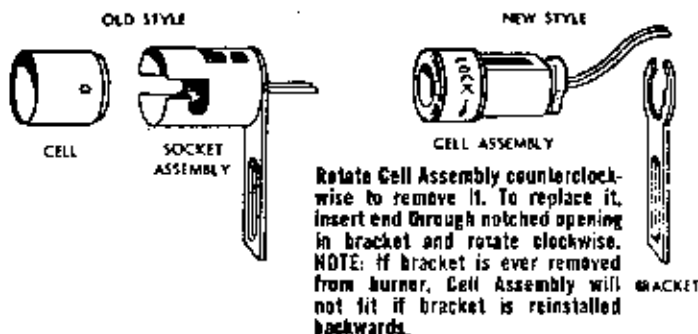

#### PART No. OF REPLACEMENT PARTS

63-0485	Cell only (Old Style)
63-2006	Cell Assembly (New Style)

4. If safety lockout problem is of an intermittent nature (only lockouts occasionally), the following additional check may be made to insure that flame detector location is not a marginal one:
  - (a) Disconnect flame detector leads from "F" terminals.
  - (b) Attach a jumper wire to one "F" terminal. Start burner. Then immediately connect jumper wire to the other "F" terminal. Burner should continue to run.
  - (c) With burner running, attach flame detector leads to an accurate ohmmeter. Reading of ohmmeter should be below 1000 ohms, and preferably as low as 500 ohms.
 

(NOTE: If indicator of ohmmeter remains steady, readings up to 2000 ohms should also be acceptable. Generally, though, the lower the reading, the better the application, and less likely the chance of a variation in the burner flame causing a safety lock-out.)
  - (d) If resistance of flame detector is over 1000 ohms, it may not be able to see the burner flame properly. Check alignment of the flame detector through the hole in the static pressure disc. Clean this hole if it is blocked by foreign matter. Check for broken "F" wires.
  - (e) If flame detector alignment is good but resistance is still high, readjustment of burner flame and/or nozzle replacement may be necessary (according to burner manufacturer's instructions).
  - (f) **WARNING:** Be sure to remove wire jumper after finishing this flame detector check.





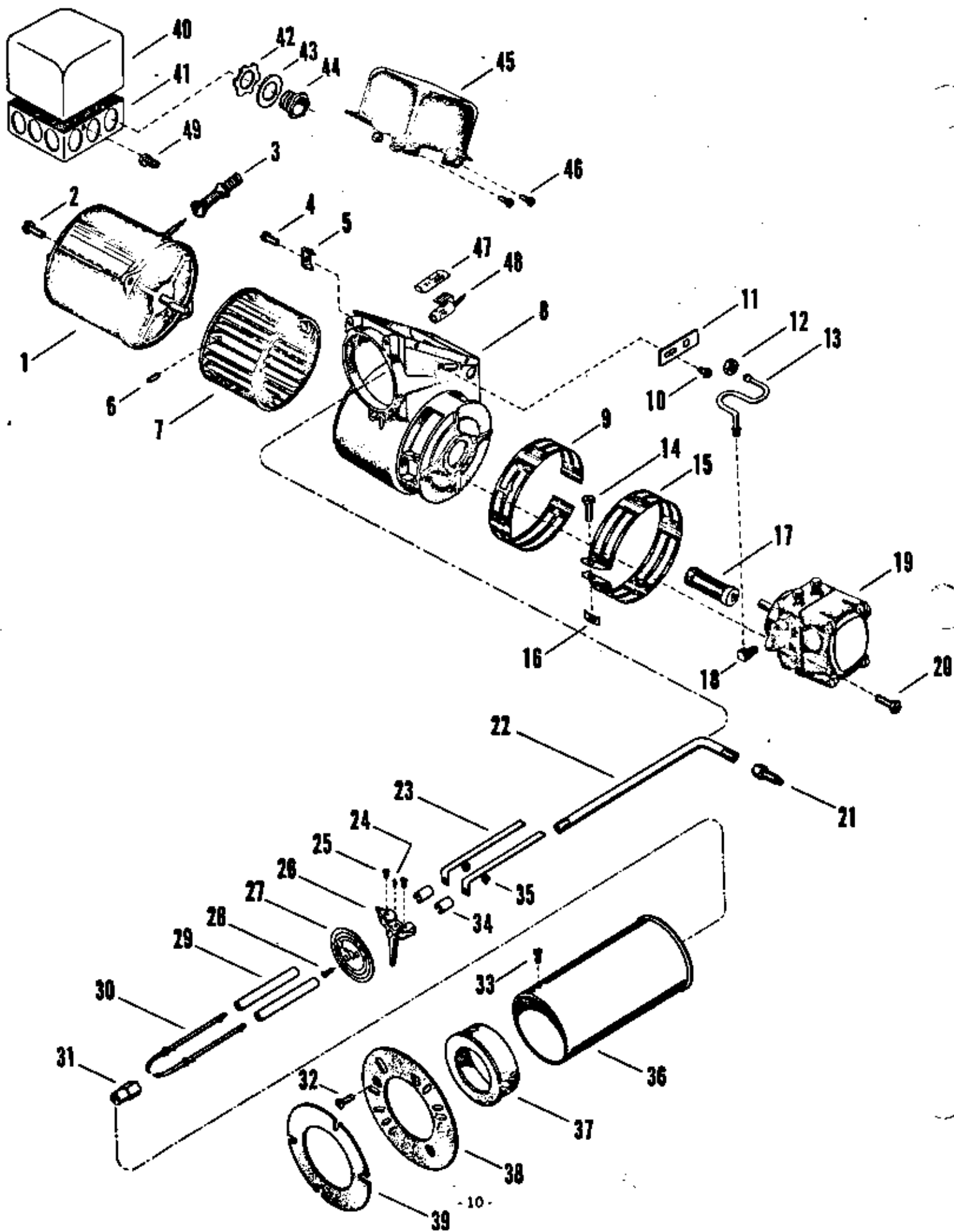

OIL BURNER PARTS LIST

<u>ITEM NO.</u>	<u>DESCRIPTION</u>	<u>MODEL OEA 6" PART NO.</u>	<u>MODEL OEA 8" PART NO.</u>
1	Motor - 1/8 hp - 1725 RPM	20382	20382
2	Motor Mounting Screw	12701	12701
3	Motor Cord Cover	13121	13121
4	Hold Down Clip Screw	13360	13360
5	Transformer Hold Down Clip	13038	13038
6	Fan Set Screw (Included w/Fan)	--	--
7	Fan, 6-1/4" Dia.	20289	20289
8	Fan Housing Assembly	4725	4725
9	Air Adjusting Band - Inner	2669	2669
10	Oil Line Slot Cover Screw	12697	12697
11	Oil Line Adj. Slot Cover	12338	12338
12	Oil Line Locknut	12342	12342
13	Oil Line Assembly	13368	13368
14	Air Band Screw	12701	12701
15	Air Adjusting Band - Outer	2668	2668
16	Tinnerman Speed Nut	12343	12343
17	Pump Coupling	13279	13279
18	Oil Line Elbow	13270	13270
19	Fuel Unit - Sundstrand ALVA-7012	13512	13512
20	Fuel Unit Mounting Screw	12701	12701
21	Oil Line Fitting	12335	12335
22	Oil Pipe for 6" Tube	12334	12346
23	Buss Bar for 6" Tube	12331	12344
24	Set Screw (Included w/Electrode Support)	--	--
25	Electrode Support Screw	12694	12694
26	Electrode Support	13418	13418
27	Baffle Plate - 3-1/2"	12567	12567
28	Baffle Plate Screw	12695	12695
29	Insulator	12354	12354
30	Electrode Stem & Washer	12550	12550
31	Nozzle Adapter	12362	12362
32	Flange Mounting Screw	12700	12700
33	Air Cone Mounting Screw	12699	12699
34	Insulator Bushing	12408	12408
35	Palnut	13110	13110
36	Air Tube - 6"	2718	2721
37	Air Cone - 2-1/4"	12337	12337
38	Flange	2685	2685
39	Gasket	12484	12484
41	J-Box	None	20369
42	Locknut - 1/2"	None	12910
43	Washer Spacer 3/4" x 1/2"	None	13167
44	Chase Nipple 1/2"	None	12909
45	Transformer - 115-60	20358	20358
46	Transformer Hinge Screw	13045	13045
47	Cad Cell Mounting Bracket	12951	12951
48	Cad Cell - As Specified	Furnished	None
49	J-Box Mounting Screw	None	13036
	Transformer Pkg. (Items 4, 5, 45 & 46)	3349	3349
	Gun Assy. (Items 21 thru 31 + 34 & 35) (600H)	2752	2756
	Electrode Assy. (Items 29, 30 & 35)	12575	12575

## COMMON CAUSES OF TROUBLE

**CAUTION** - To avoid accidents, always open main switch (OFF position) when servicing burner.

**BURNER WILL NOT PRODUCE FLAME** - Check oil level gauge to see that there is sufficient oil in tank or tanks. Check the burner mounted relay control. **DO NOT ADJUST THIS CONTROL.**

Check position of electrodes; incorrect position will cause slow or delayed ignition. Clean electrodes and nozzle. Check and clean strainer in pump. If oil line filter is used, check filter condition.

**BURNER STARTS OR STOPS TOO OFTEN** - Limit control may be set too low.

**NOZZLE PRODUCES A STRINGY FLAME** - Worn tangential grooves in nozzle. Replace nozzle.

**BASINENT TANK HUM** - Occasionally with a two-pipe installation there may be a low return line hum. Eliminate hum by installing a special anti-hum valve in the return line near pump.

**HEAVY PIRE OR PULSATING FLAME** may occur after burner starts. It may be caused by a slight oil leak in the fuel pump and cannot be corrected except by replacing the pump. This happens only when the burner is started.

**CHATTERING SOUND OR HIGH FITCH NOISE** from motor can usually be traced to where a conduit or BX cable is fixed rigidly or attached to some part of the building. Relieving this strain may eliminate noise.

**PUMP SQUEALS OR CHATTERS** - This may be caused by air in pipes. Check all joints in the oil supply pipe for leaks. Check strainer in pump; if dirty, clean.

**INSUFFICIENT HEAT** - Check limit control setting. It may be that flame is not allowed to stay on long enough to generate sufficient heat in furnace to heat the house properly. If the proper size furnace has been selected according to house requirements and satisfactory heat is not obtained, recheck the heating plant for size and capacity in relation to house. Check for clogged filters.

## CARE OF FINISH

Your unit is painted with baked enamel. Like a good piece of furniture, it has an excellent appearance and an occasional waxing and dusting will keep it attractive for years.

## CLEANING OF FURNACE

All units have one or more clean out plugs for easy cleaning of the heat exchanger. They are accessible either from the front or back on some units and the sides on other units. The furnace should be checked periodically to see if it needs cleaning.

## REPLACEMENT OF PARTS

When ordering parts please give model and serial number of your unit. If parts are not available from the installing dealer, please contact Service Department, Bard Manufacturing Company, P. O. Box 607, Bryan, Ohio 43506, telephone 19-636-1194.