

MANUAL 2100-007C



**MODEL  
B36EHQ1  
BLOWER COIL UNIT**

**INSTALLATION INSTRUCTIONS**

**FOR RESIDENTIAL AND COMMERCIAL  
HEATING / COOLING APPLICATIONS**

**BARD MANUFACTURING CO. • BRYAN, OHIO 43506**

*Dependable quality equipment. . . since 1914*

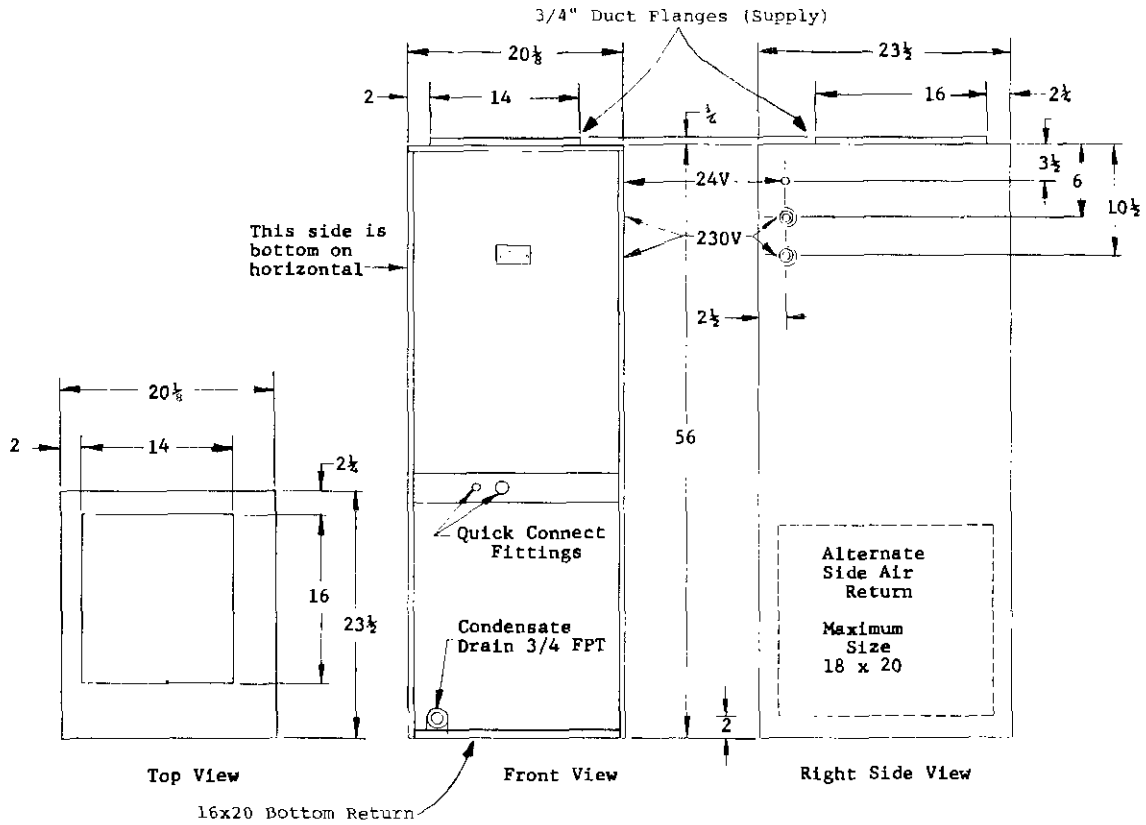

B36EHQ1  
AIRFLOW PERFORMANCE DATA

MAXIMUM E.S.P. OPERATION INFORMATION*			
Type of Application	Rating of Electric Heaters**	BLOWER MOTOR SPEED	
		Low	High
Heat Pump	20Kw	.30	.45
Heat Pump	15Kw	.50	.50
Heat Pump	10Kw	.60	.60
Heat Pump	5Kw	.60	.60
Air Conditioning	30Kw	.60	.60
Air Conditioning	25Kw	.60	.60
Air Conditioning	20Kw	.60	.60
Air Conditioning	15Kw	.60	.60
Air Conditioning	0,5,10Kw	.60	.60

\*Values shown are for standard bottom return air opening. For alternate side return air opening, add .05 to values shown.  
 \*\*Maximum of 20Kw to be energized with heat pump. See "Heat Pump With Electric Heat," for complete details.

B36EHQ1 BLOWER PERFORMANCE		
E.S.P. Inches H <sub>2</sub> O	CFM - DRY COIL WITH FILTER	
	Low Speed	High Speed
.00	1250	1485
.10	1215	1430
.20	1180	1375
.30	1150	1320
.40	1100	1265
.50	1050	1190
.60	975	1115

RECOMMENDED AIRFLOW RANGE BASED ON OUTDOOR UNIT SIZE

30ECQ2, 31ECQ or 30HPQ4 --- 800-1100 CFM  
 36ECQ4, 37ECQ or 36HPQ4 --- 975-1300 CFM

## GENERAL

Units are shipped completely assembled and internally wired, requiring only duct connections, thermostat wiring and external 220-240 volt AC power supply.

The same B36EHQ1 air handler, with its various Kw electric heat options, is suitable for use with the following air conditioner and heat pump outdoor sections. It can be used both as an air conditioning system with electric heat and as a heat pump with electric heat. Refer to sections titled, Air Conditioning With Electric Heat and Heat Pump With Electric Heat, for complete information.

### APPROVED OUTDOOR UNITS

<u>AIR CONDITIONERS</u>	<u>HEAT PUMPS</u>
30ECQ2, 31ECQ	30HPQ4
36ECQ4, 37ECQ	36HPQ4

The B36EHQ1 is provided with a 55VA transformer and a heating-cooling blower relay. All models manufactured with 15Kw or more resistance heating also are supplied with fused, sub-divided circuits. Refer to electrical specifications and field wiring data for complete information.

## UNPACKING

Upon receipt of equipment, carton should be checked for external signs of damage. If damage is found, request for inspection by carrier's agent should be made in writing immediately.

## INSTALLATION

Size of unit for a proposed installation should be based on heat loss calculation made according to methods of National Warm Air Heating and Air Conditioning Association. The air duct should be installed in accordance with the Standards of the National Fire Protection Association for the Installation of Air Conditioning and Ventilating Systems of Other Than Residence Type, NFPA No. 90A, and Residence Type Warm Air Heating and Air Conditioning Systems, NFPA No. 90B. Where local regulations are at a variance with instructions, installer should adhere to local codes.

## DUCTWORK

Design the ductwork according to methods given by the National Warm Air Heating and Air Conditioning Association. When duct runs through unheated spaces, it should be insulated with a minimum of two inches of insulation. Use insulation with a vapor barrier on the outside of the insulation. Flexible joints should be used to connect the ductwork to the equipment in order to keep the noise transmission to a minimum.

## RETURN AIR DUCT CONNECTIONS

Flange return air duct and secure to either bottom or side return, depending on installation.

NOTE: If no return air duct is used, applicable installation codes may limit this cabinet to installation only in a single story structure.

## LOCATION AND CLEARANCES

All access to the equipment is from one side, and at least 24 inches should be provided from this side for service access.

Unit casing is suitable for 0 inch clearance. The first two (2) feet of ductwork attached to the outlet (supply air) connections of the unit are to have a minimum of 1 inch clearance, with 0 inch clearance for any remaining ductwork.

Unit may be installed in utility room, closet, basement, attic, or closed crawl space in either upflow or horizontal position.

When installed horizontal in an attic installation, a platform should be made for the unit to sit on. This platform can be made from 3/4 inch plywood or boards. An auxiliary drain pan should always be used when equipment is installed over a finished living area, to provide protection from water damage in case of plugging of the primary drain line from the unit condensate collection pan.

Secure four pieces of cork or live rubber, 4" x 4", of sufficient thickness to allow primary drain to clear edge of auxiliary drain pan, under each corner of the unit.

## CONDENSATE DRAIN

Determine where the drain line will run. This drain line contains cold water and must be insulated to avoid drops of water from dropping on ceiling, etc. A trap must be installed in the primary drain line below the bottom of the drain pan.

For horizontal installations with auxiliary drain pan, a separate drain line should be run from the auxiliary drain pan and terminated where the homeowner can see it. Be certain to show the homeowner the location of the drain line and to explain its purpose. In the event of overflow of primary drain, water will collect in auxiliary pan and run out through the auxiliary drain line.

It is not recommended that any condensate drain lines be connected to a sewer main. Drain lines must be installed in accordance with local codes.

## INTERCONNECTING TUBING

It is recommended that the interconnecting tubing be the CT-series charged tubing sets. This is a precharged tubing set with an insulated suction line. Both suction and liquid line are equipped with the correct quick connect fittings for proper match up to the indoor and outdoor sections. The CT-series is available in standard tubing lengths of 15, 25, 35 and 45 feet.

## FILTER

This unit must not be operated without a filter. It comes equipped with a replaceable fiberglass 22x22x1 type filter that slides in and out through the filter access opening. It is so located that no changes are required if the optional side return air opening is selected to be used. The filter should be replaced periodically throughout the year, as this is a heating and cooling system and operates year round.

## THERMOSTAT LOW-VOLTAGE WIRING

A 24V terminal block is mounted on the inside of the unit. There is also a 24V terminal block located in the outdoor section of remote heat pumps and two tagged 24V wires in the outdoor section of remote air conditioners.

Specific control circuit connection diagrams for the various applications are referenced in the sections titled "AIR CONDITIONING WITH ELECTRIC HEAT" and "HEAT PUMP WITH ELECTRIC HEAT." These diagrams detail the recommended controls and wiring to allow the best possible operation of the different types of systems with respect to energy conservation while still maintaining close comfort levels for the occupant.

## TWO SPEED BLOWER MOTOR

The ATR HANDLER is supplied with a multiple speed blower motor, using two speed taps to provide airflow variation for the different basic capacity ratings of the outdoor sections.

### MOTOR SPEED IDENTIFICATION

Common	-	Yellow
High	-	Black
Low	-	Red
Capacitor	-	Brown

The HEATING-COOLING BLOWER RELAY provides for single blower speed operation of the motor. A manual change-over can be made by changing the motor speed tap that is connected to the blower relay.

The unused speed tap must be taped securely and individually from one another so as not to short out the motor. Refer to unit wiring diagram for correct identification of relay terminals.

All B36EHQ1's are shipped wired on high speed. Refer to B36EHQ1 specification sheet for airflow performance chart on different motor speeds.

The "Maximum E.S.P. Operation Information" details the available maximum static pressure for the various applications, depending on Kw and motor speed.

## ELECTRICAL DATA

MODEL	VOLTS/PH	KW	<sup>1</sup> AMPS	NO. OF CKTS.	MIN. CKT. AMPACITY Ckt. A/B	MAX. FUSE OR CKT. BREAKER Ckt. A/B <sup>2</sup>	FIELD WIRE SIZE Ckt. A/B <sup>3</sup>	GROUND WIRE SIZE Ckt. A/B <sup>3</sup>
B36EHQ1	240/1	0	2.1	1	15	15	14	14
		5	22.9	1	29	30	10	10
		10	43.7	1	55	60	6	10
		15	64.5	1	81	90	3	8
		20	85.3	1	107	110	2	6
		25	106.1	2	55/78	60/80	6/3	10/8
		30	126.9	2	55/104	60/110	6/2	10/6

<sup>1</sup> Total unit amps including blower motor.

<sup>3</sup> Table based on 60°C copper wire for ampacity ratings 100 or less and 75°C copper wire for ampacity ratings over 100.

<sup>2</sup> Time delay fuses or "HACR Type" circuit breakers must be used for 60 and smaller sizes. Standard fuses or circuit breakers are suitable for 70 and larger.

### UNIT OPERATION

The controls in the B36EHQ1 provide for manual/auto fan control in addition to the staging of the installed electric heat. Staging is accomplished in basic 10Kw increments, that is, each two (2) heating elements are controlled by one heat relay.

HEATER ELEMENT STAGING	
Heater Kw	Stages
5, 10	1
15, 20	2
25, 30	3

Heater stage designations are as follows on the 24V terminal strip:  
 W2 - 1st stage  
 W3 - 2nd stage  
 DH - 3rd stage

### AIR CONDITIONING WITH ELECTRIC HEAT

Typical situations would be to utilize a 1-stage cool, 1-stage heat wall thermostat for 5 and 10Kw applications, and a 1-stage cool/2-stage heat thermostat for 15 and 20Kw applications. The 24 and 30Kw applications can be wired using an outdoor thermostat to control the 3rd stage heat relay. Listed below are the appropriate control circuit connection diagrams based upon Kw rating and also the number of field installed A-22 outdoor thermostats, Bard Part No. 8408-001, required for each application:

B36EHQ1 KW Rating	Connection Diagram	Quantity of A-22's
0	CCD-1	0
5, 10	CCD-2	0
15, 20	CCD-3	0
25, 30	CCD-4	1

### HEAT PUMP WITH ELECTRIC HEAT

The system and its safety controls are designed in such a manner that the heat pump and up to 20Kw of the resistance strip heaters can operate at the same time, being brought on in stages. This does not rule out the possibility of there being a total installed Kw of 30Kw in the B36EHQ1; 20Kw of which can be operated in conjunction with the heat pump, and the remaining 10Kw (L - 3rd stage heat contactor) being utilized as heat pump "replacement" heat. This feature of "replacement" heat is normally used in the colder northern climates where emergency heat switches and compressor cut-offs are considered required equipment. This allows for total heating capability for the structure in case of a malfunction in the outdoor heat pump.

Listed below are the appropriate control circuit connection diagrams based on Kw rating, and also the number of field installed A-22 outdoor thermostats, Bard Part No. 8408-001 (10°- 45°F range), or 8408-005 (0-30°F range), recommended for each application:

B36EHQ1 Kw Rating	Connection Diagram	Quantity of A-22's
0	CCD-5	0
5, 10	CCD-6	1
15, 20	CCD-7	1
25, 30	CCD-8	2

In geographical areas where compressor cut-off would not be required because winter temperatures below 10°F are never experienced, disregard the compressor cut-off wiring shown on the control circuit diagrams.

### WALL THERMOSTATS

The following wall thermostats and subbases should be used as indicated, depending on the application.

Application	KW	THERMOSTAT		SUBBASE	
		Bard Part No.	Description	Bard Part No.	Description
A/C	5, 10	8403-002	T87F3111	8404-003	Q539A1220
A/C	15, 20	8403-019	T874C1000	8404-012	Q674A1001
A/C	25, 30	8403-019	T874C1000	8404-012	Q674A1001
H/P	All <sup>1</sup>	8403-017	T874R1129	8404-009	Q674L1181
H/P	All <sup>2</sup>	8403-018	T874N1024	8404-010	Q674F1261

<sup>1</sup> No automatic changeover position—must manually place in heat or cool. Reversing valve remains energized at all times system switch is in heat position (except during defrost cycle). No pressure equalization noise when thermostat is satisfied on either heating or cooling.

<sup>2</sup> Allows thermostat to control both heating and cooling operation when set in "AUTO" position. Reversing valve de-energizes at end of each "ON" heating cycle.

**IMPORTANT NOTE:** Both thermostat and subbase combinations shown above incorporate the following features; Man-Auto fan switch, Off-Heat-Cool-Em. Heat Switch, and two (2) indicator lamps—one for emergency heat and one for compressor malfunction.

24V CONTROL CIRCUIT CONNECTION DIAGRAMS

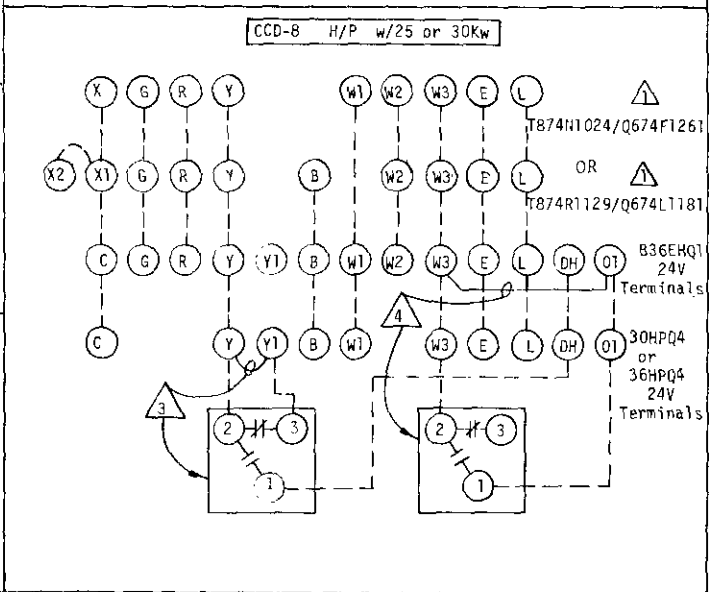
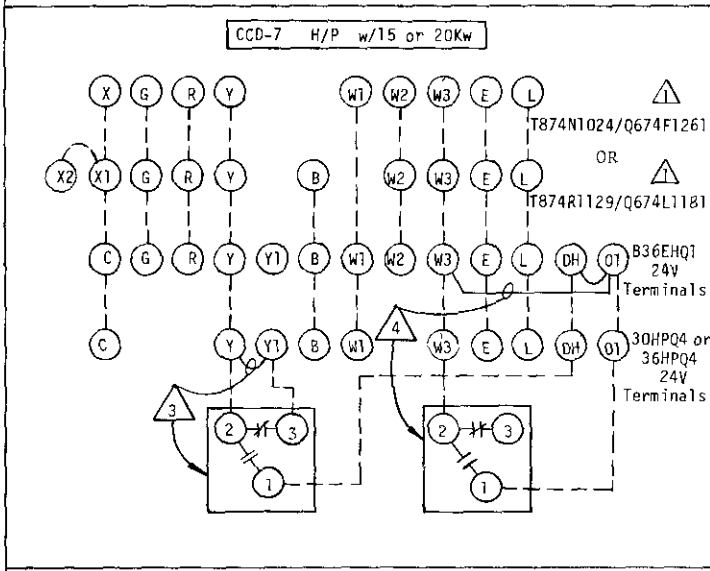
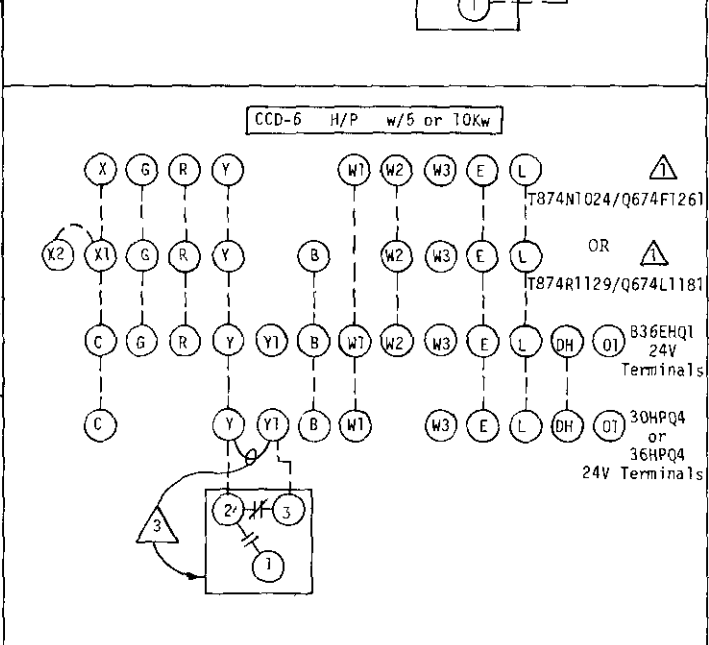
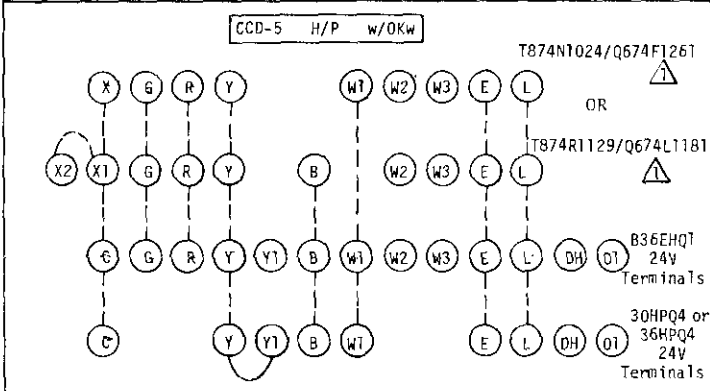
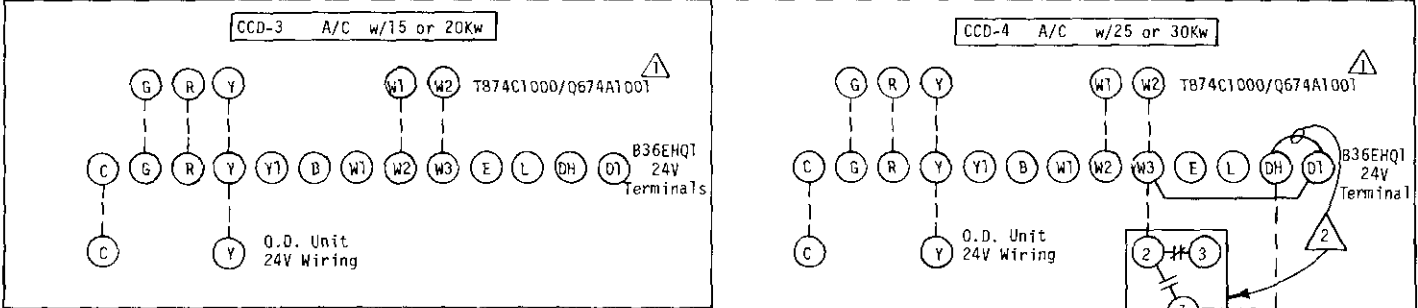
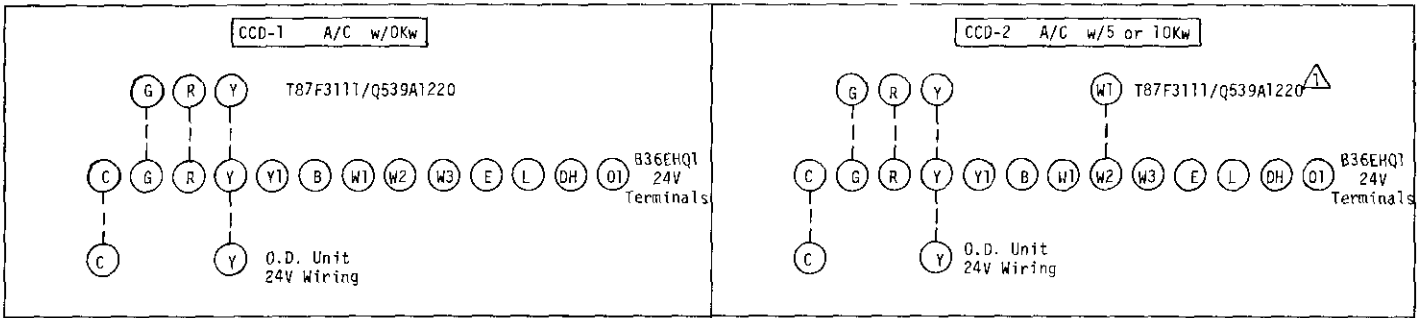

- 1 Set adjustable heat anticipator at .40A.
- 2 If optional outdoor thermostat is used, DO NOT install jumper between DH - O1.
- 3 If optional compressor cutoff is installed, remove jumper Y - Y1.
- 4 If optional outdoor thermostat is used, remove jumper W3 - O1.

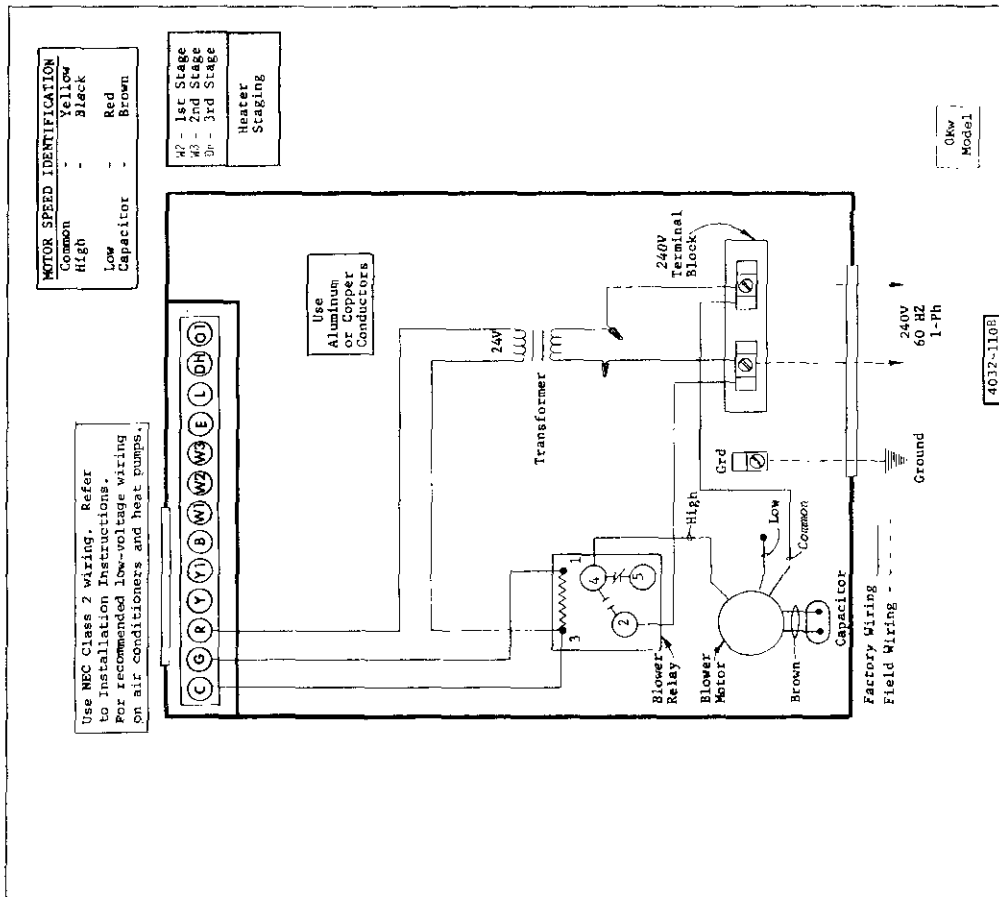
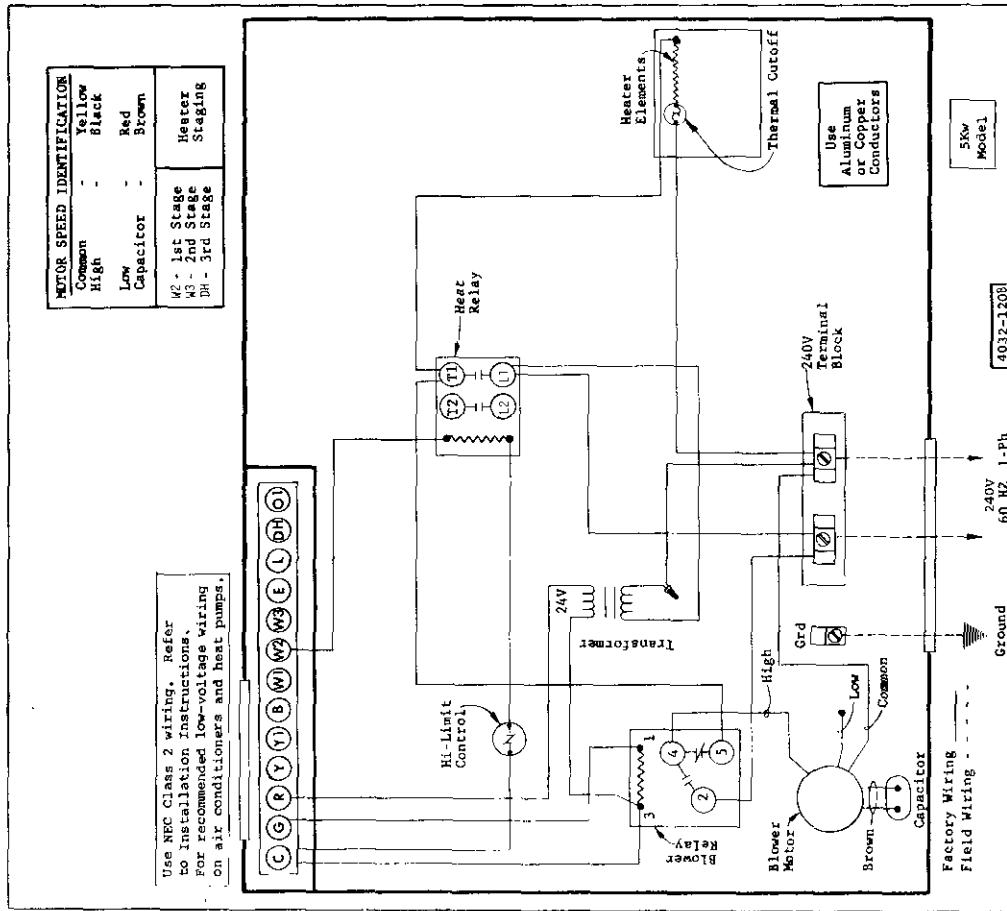

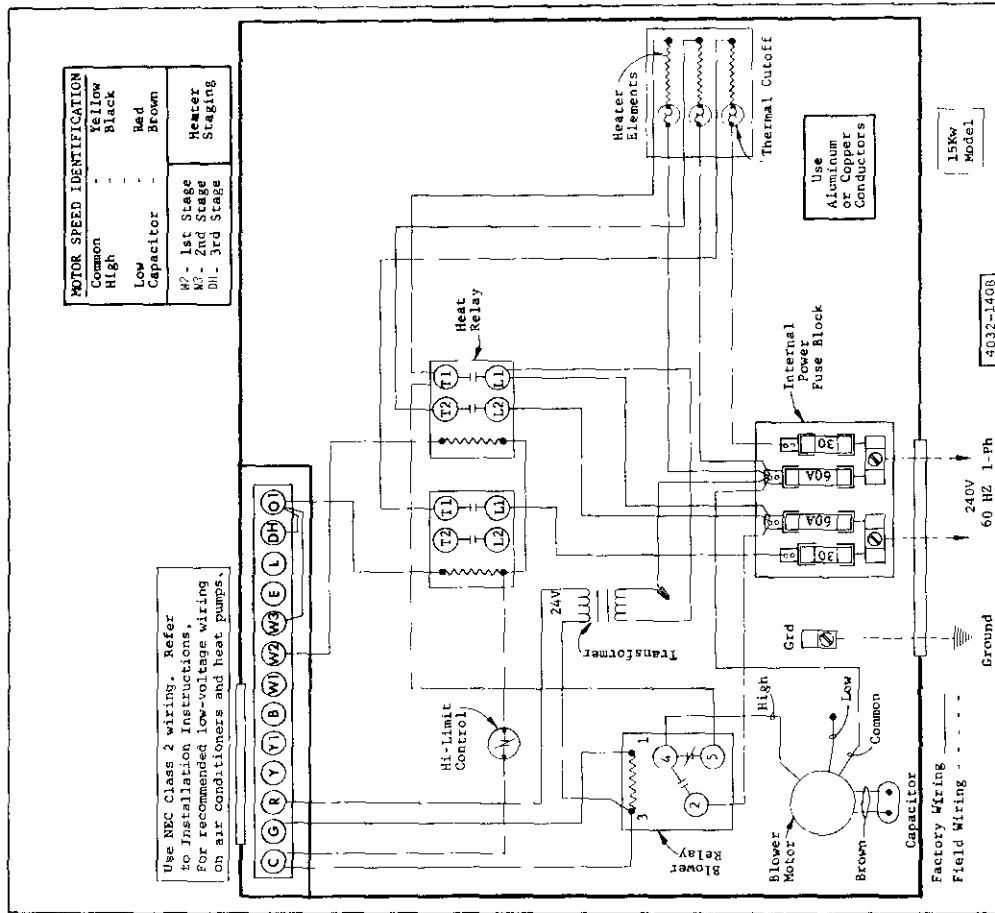
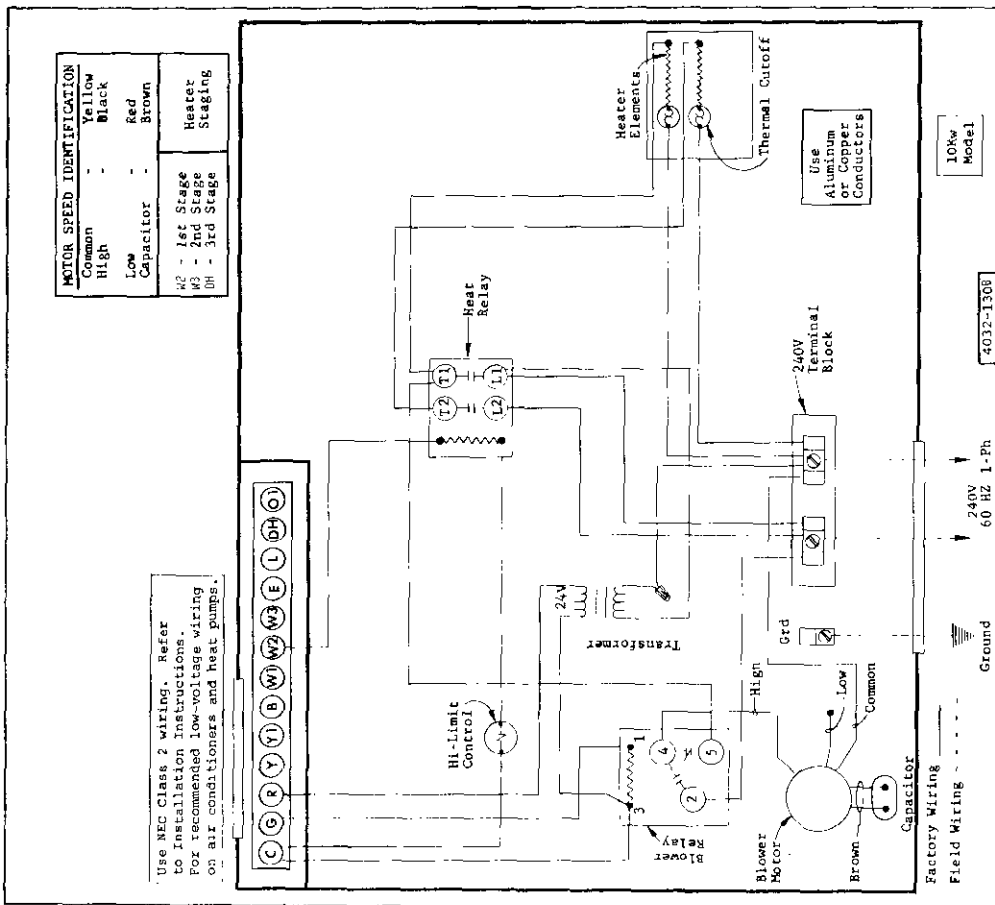

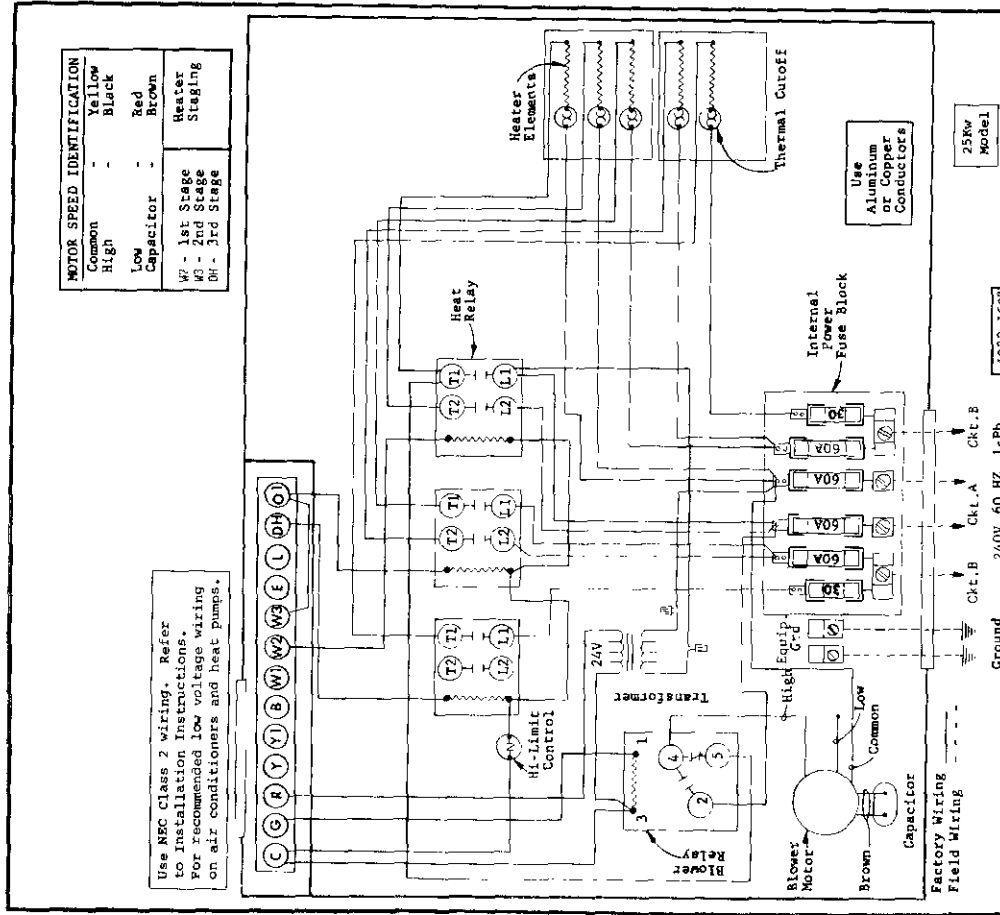
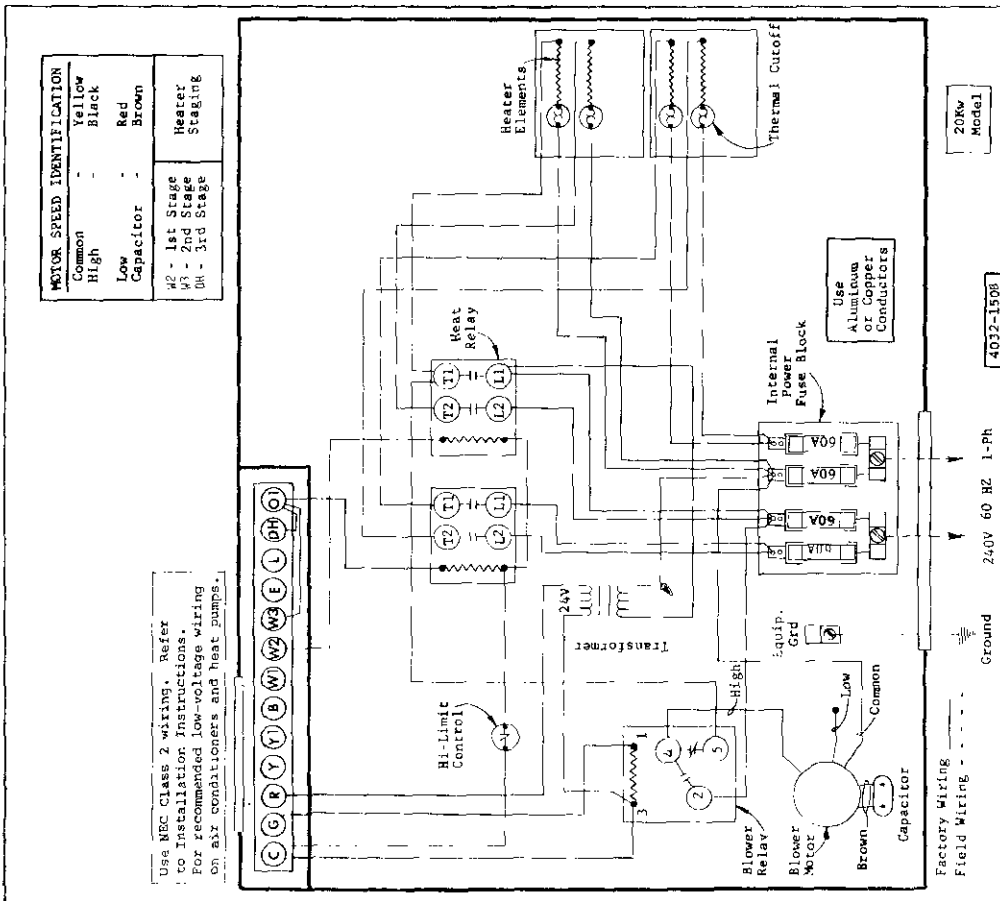



MOTOR SPEED IDENTIFICATION	
Common	- Yellow
High	- Black
Low	- Red
Capacitor	- Brown
W2 - 1st Stage	Heater
W3 - 2nd Stage	Staging
W4 - 3rd Stage	Staging

Use NEC Class 2 wiring. Refer to Installation Instructions. For recommended low voltage wiring on air conditioners and heat pumps.

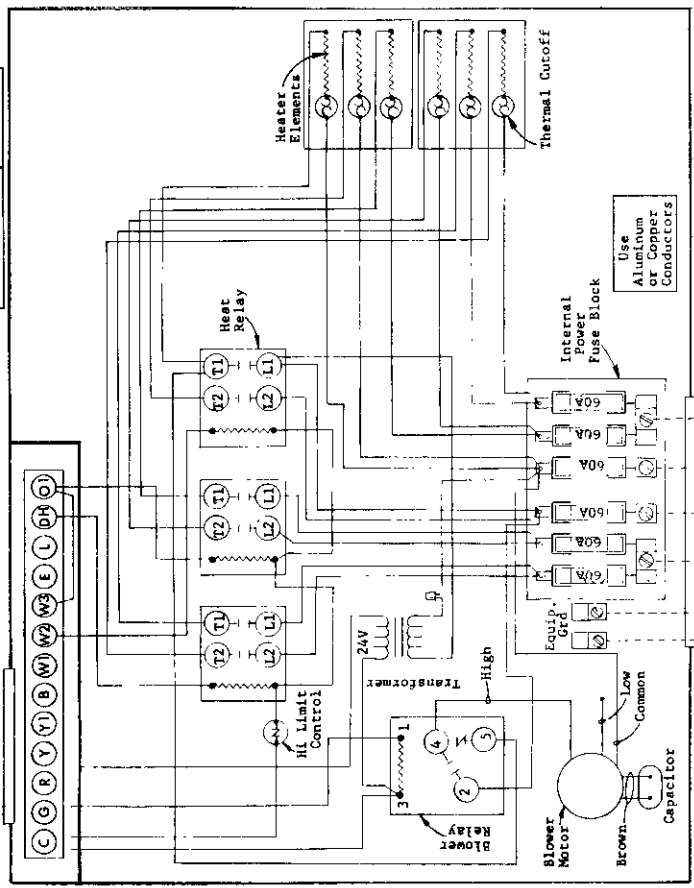

30kw Model  
4032-170B  
240V 1-Ph 60Hz  
Ground  
Ckt. B  
Ckt. A  
Ckt. B  
Internal Power Fuse Block  
Use Aluminum or Copper Conductors  
Blower Motor  
Brown - Low  
Common  
Capacitor  
Factory Wiring - - -  
Field Wiring - - -

PARTS LIST  
SPLIT SYSTEM BLOWER COILS

Effective 1/1/82  
Supersedes 1/1/80

PART NO.	DESCRIPTION	B18EQ1	B24EQ1	B18EHQ1	B24EHQ1	B36EHQ1	B48EHQ1	B60EHQ1
*	Blower Housing 10-4	x						
*	Blower Housing 10-9							
*	Blower Housing 10-10							
5152-043	Blower Housing 12-7							
5152-008	Blower Wheel 0010-4A	x						
5152-014	Blower Wheel 0010-9A							
5152-015	Blower Wheel 10-10							
5152-044	Blower Wheel							
8552-001	Capacitor 4/370V	x						
8552-002	Capacitor 5/370V							
8552-025	Capacitor 7-1/2 -440V							
8552-005	Capacitor 10/370V							
5811-004	Capillary Tube	(3)						
5811-001	Capillary Tube		(3)					
5811-035	Capillary Tube			(3)				
5811-010	Capillary Tube							
5811-009	Capillary Tube						(4)	(4)
5651-006	Check Valve							
5651-036	Check Valve							
8401-006	Contact - Heater 20A	x						
8401-010	Contact - Heat 3-Ph							
8401-001	Contact - Heat 3-Ph							
5060-003	Evaporator Coil	x						
5060-016	Evaporator Coil							
5060-028	Evaporator Coil							
5060-012	Evaporator Coil							
5060-020	Evaporator Coil							
7004-003	Filter 12x20							
7004-017	Filter 22x22							
7004-015	Filter 24x24							
8614-006	Fuse - Heater 30A							
8614-007	Fuse - Heater 60A							
8614-035	Fuse - Heater 35A 3-Ph							
8614-033	Fuse - Heater 45A 3-Ph							
8614-032	Fuse - Heater 40A 3-Ph							
8614-017	Fuse Block 15Kw							
8614-014	Fuse Block 25Kw							
8614-019	Fuse Block 30Kw							
8614-018	Fuse Block 20Kw							
8614-020	Fuse Block 30Kw 3-Ph							
8614-021	Fuse Block 3-Ph							
8604-027	Heat Strip 4Kw	x						
8604-023	Heat Strip 5Kw	x						

PARTS LIST  
SPLIT SYSTEM BLOWER COILS

Effective 1/1/82  
Supersedes 1/1/80

PART NO.	DESCRIPTION	B18EQ1	B24EQ1	B18EHQ1	B24EHQ1	B36EHQ1	B48EHQ1	B60EHQ1
8604-026	Heat Strip 8Kw	x						
8604-024	Heat Strip 10Kw	x						
8604-025	Heat Strip 15Kw							
8604-035	Heat Strip 9Kw							
8604-036	Heat Strip 12Kw							
8604-032	Heat Strip 9Kw 460v							
8402-029	Limit Switch L160-2.5							
8402-028	Limit Switch L150-2.5	x						
8402-022	Limit Switch L145-2.5							
8402-033	Limit Switch L140-2.5							
8402-012	Limit Switch L130-1.5							
8102-004	Motor - Blower 1/6	x						
8103-012	Motor - Blower 1/5							
8105-022	Motor - Blower 1/3							
8106-013	Motor - Blower 1/2							
8107-003	Motor - Blower 3/4							
8200-003	Motor Mount	x						
8200-021	Motor Mount							
5451-011	Motor Mounting Parts	x						
8201-009	Relay - Blower	x						
8201-014	Relay - Blower							
8201-013	Relay - Emergency Heat							
5210-003	Strainer	x						
5210-006	Strainer							
8607-006	Terminal Board 24V	x						
8607-001	Terminal Block 230V	x						
8607-002	Terminal Block 3-Ph							
8607-010	Terminal Block							
8607-003	Terminal Block 15Kw							
8402-025	Thermal Cut-off							
8402-027	Thermal Cut-off	x						
8407-007	Transformer	x						
8407-015	Transformer							
8407-022	Transformer							
8407-003	Transformer 9Kw 3-Ph 460v							



