

MANUAL 2100-004E

INSTALLATION INSTRUCTIONS

**EFC-1 SERIES
ELECTRIC FURNACES**

,

,

,

GENERAL

Units are shipped completely assembled and internally wired, requiring only duct connections, thermostat wiring and external 220-240V power supply. These furnaces have provision inside of unit for installation of a cooling coil (field or factory installed).

| <u>Furnace Model</u> | <u>Cooling Coil Model</u> |
|----------------------|---------------------------|
| EFC5-1 | 2ACQ1 |
| EFC10-1 | 2ACQ1 |
| EFC10-1-B | 3ACQ3 |
| EFC15-1 | 3ACQ3 |
| EFC20-1 | 3ACQ3 |
| EFC25-1 | 3ACQ3 |
| EFC30-1 | 3ACQ3 |

IN ADDITION TO THE STANDARD CENTRAL HEATING TESTS, THESE FURNACES HAVE ALSO BEEN TESTED FOR MOBILE HOME INSTALLATION. All units are provided with a 24V transformer and 2-speed cooling relay as standard equipment. The Underwriter's Laboratories, Inc. label applies only to the furnace and not to any air conditioner which may be added, or part of the furnace.

INSTALLATION

Size of unit for a proposed installation should be based on heat loss calculation made according to methods of Air Conditioning Contractors of America. The air duct should be installed in accordance with the Standards of the National Fire Protection Association for the Installation of Air-Conditioning and Ventilating Systems of Other Than Residence Type, NFPA No. 90A and Residence Type Warm Air Heating and Air-Conditioning Systems, NFPA No. 90B. Where local regulations are at a variance with instructions, installer should adhere to local codes.

DUCTWORK

Design the ductwork according to methods given by the Air Conditioning Contractors of America. When duct runs through unheated spaces, it should be insulated with a minimum of two inches of insulation. For heating and cooling installation or future cooling, use insulation with a vapor barrier outside the insulation. Flexible joints should be used to connect the ductwork to the furnace in order to keep noise transmission at a minimum.

NOTE: If no return air duct is used, applicable installation codes may limit this cabinet to installation only in a single story residence. Return air duct is attached by flanging the return air duct and attaching with screws to the bottom of the furnace.

UNPACKING

When received, carton should be checked for external signs of damage. If damage is found, request for inspection by carrier's agent should be made in writing immediately.

LOCATION AND CLEARANCES

At least 24 inch service access clearance from access panels should be provided. Furnace casing, plenum and warm air duct are suitable for 0 inch clearance from combustible material.

Unit may be installed in utility room, closet, basement, attic, mobile home, or closed crawl space for UPFLOW, HORIZONTAL or DOWNFLOW application.

UPFLOW - No special mounting instructions are required, except when installed in a mobile home. See Figure A.

HORIZONTAL INSTALLATION - When installed in horizontal position (and cooling coil is added later) the electric power entrance side must be located at the top.

Whenever the furnace is installed with a cooling coil, in the horizontal position, an auxiliary water pan is required. See Figure B.

DOWNFLOW INSTALLATION - In downflow installations an EFC MOUNTING BASE is required. Set the EFC MOUNTING BASE in position, mark the floor and cut the hole. After the floor opening has been made, set the EFC BASE in place. Secure the base to the floor with wood screws through the holes provided. Set the furnace in place and secure it to the base with sheet metal screws through the holes provided.

The furnace must be secured at the top. Remove the upper access door and fasten either side of the furnace to a vertical wall partition with wood screws through the holes provided.

MOBILE HOME - See Mobile Home Installation Instructions, Figure A.

EVAPORATOR COIL INSTALLATION - There is a coil cavity built into the furnace cabinet designed to accommodate the following air conditioner coils: Models 2ACQ1 and 3ACQ3.

No special parts are needed for upflow or downflow installation. Simply remove the front panel and insert the coil into position. Re-install the coil door panel after removing the blank-off plate where the tubing connections project out. This panel is reversible and is simply turned over for downflow installations.

For horizontal installation an EFC-1 auxiliary water pan MUST BE used in conjunction with the basic coil assembly.

See Figure B for illustrations on all three of the installation options.

FILTER

THIS UNIT MUST NOT BE OPERATED WITHOUT FILTER. Filter is at the intake end of the furnace and the filters are secured in place with an angle cross bar. To remove filters, disengage the angle bar and lift out the filters. Replacement filter should be of the same type that was originally supplied.

Foam or permanent filters can be cleaned by washing in warm soapy water and rinsing clean.

WIRING

All electrical wiring must comply with the National Electrical Code and all local ordinances.

Connect 24V thermostat wires to terminal strip mounted on inside of the unit.

Connect 220-240V power leads to terminal block or fuse panel located inside the unit. One field power circuit is required up through the 15Kw models, and two field power circuits are required on 20Kw models and higher.

Equipment grounding terminals are supplied on the basis of one per each field power circuit.

Internal wiring of the furnace model is shown on the wiring diagram attached to the control panel cover.

FUSING

Models EFC15-1, EFC20-1, EFC25-1 and EFC30-1 are provided with fused sub-divided circuits.

24V TRANSFORMER

A 40VA transformer is built-in and supplies necessary capacity for operation of furnace controls as well as add-on air conditioning unit controls.

HEAT-COOL BLOWER RELAY

A heat-cool blower relay is built-in, providing for each application of add-on air conditioning. No additional wiring is required other than the additional 24V wiring from the outdoor air conditioning unit.

THERMOSTAT

For heat only applicatons, a heat only thermostat with or without a manual fan switch can be used.

For heat-cool applicatons with add-on air conditioning, when the air conditioner has its own 24V transformer, "Use Thermostat With Isolating Contacts To Prevent Inter-connection of Class 2 Outputs."

Most air conditioners do not have a transformer in the outdoor section, therefore an isolating contact thermostat is not required. An isolating thermostat may be used, but terminals RC-RH must be jumpered together on the subbase.

HEATER STAGING

The Kw rating of the furnace dictates the number of thermostatic control stages when wired at the factory. Listed below by model number are the heater stages as shipped:

| Model | KW | Stages |
|-----------|----|--------|
| EFC5-1 | 5 | 1 |
| EFC10-1 | 10 | 1 |
| EFC10-1-B | 10 | 1 |
| EFC15-1 | 15 | 1 ① |
| EFC20-1 | 20 | 1 ① |
| EFC25-1 | 25 | 2 ② ③ |
| EFC30-1 | 30 | 2 ② ③ |

- ① Can be changed to 2-stage by removing jumper wire W1-W2 at 24V terminal block.
- ② Can be set up for 3-stage using optional outdoor thermostat and removing jumper W2-F at 24V terminal board.
- ③ Can be changed to 1-stage by adding jumper W1-W2.

HEAT ANTICIPATOR SETTINGS

For proper temperature control the thermostat heat anticipator must be set to match the current draw of the electric heater contactors.

| Model | Set Up For 1-Stage | Set Up For 2-Stage | |
|-----------|--------------------|--------------------|---------|
| | | Stage 1 | Stage 2 |
| EFC5-1 | .40 | -- | -- |
| EFC10-1 | .40 | -- | -- |
| EFC10-1-B | .40 | -- | -- |
| EFC15-1 | .80 | .40 | .40 |
| EFC20-1 | .80 | .40 | .40 |
| EFC25-1 | 1.2 | .40 | .80 |
| EFC30-1 | 1.2 | .40 | .80 |

MULTI-SPEED BLOWER MOTOR

The EFC Series furnace is supplied with a multi-speed direct drive motor using either two or three "taps" to provide speed and airflow variation. Models EFC5-1 and EFC10-1 are two speed motors and do not have a motor capacitor. All other models use a three speed motor.

MOTOR SPEED IDENTIFICATION

- Yellow - Common
- Brown - Capacitor
- Black - High
- Blue - Medium
- Red - Low

All furnaces are wired low speed on heating and either medium or high speed on cooling. The cooling speed is the same as Manual Fan Operation. The following chart is how the speed taps are connected at the factory.

MOTOR SPEED CONNECTIONS

| Model | Heating | Cooling |
|-----------|---------|---------|
| EFC5-1 | Low | High |
| EFC10-1 | Low | High |
| EFC10-1-B | Low | High |
| EFC15-1 | Low | High |
| EFC20-1 | Low | High |
| EFC25-1 | Low | Medium |
| EFC30-1 | Low | Medium |

MOBILE HOME INSTALLATION INSTRUCTIONS

A furnace installed in a mobile home shall be permanently mounted.

UPFLOW INSTALLATION

In upflow installations an EFC MOUNTING BASE is not required but the furnace must be secured to the floor. Remove the lower access door and fasten the bottom to the floor with wood screws.

The furnace must be secured at the top. Remove the upper access door and fasten either side of the furnace to a vertical wall partition with wood screws through the holes provided.

DOWNFLOW INSTALLATION

In downflow installations an EFC MOUNTING BASE is required. Set the EFC MOUNTING BASE in position, mark the floor and cut the hole. After the floor opening has been made, set the EFC BASE in place. Secure the base to the floor with wood screws through the holes provided. Set the furnace in place and secure it to the base with sheet metal screws through the holes provided.

In addition to installing the furnace with an EFC MOUNTING BASE, the furnace must be secured at the top. Remove the upper access door and fasten either side of the furnace to a vertical wall partition with wood screws through the holes provided.

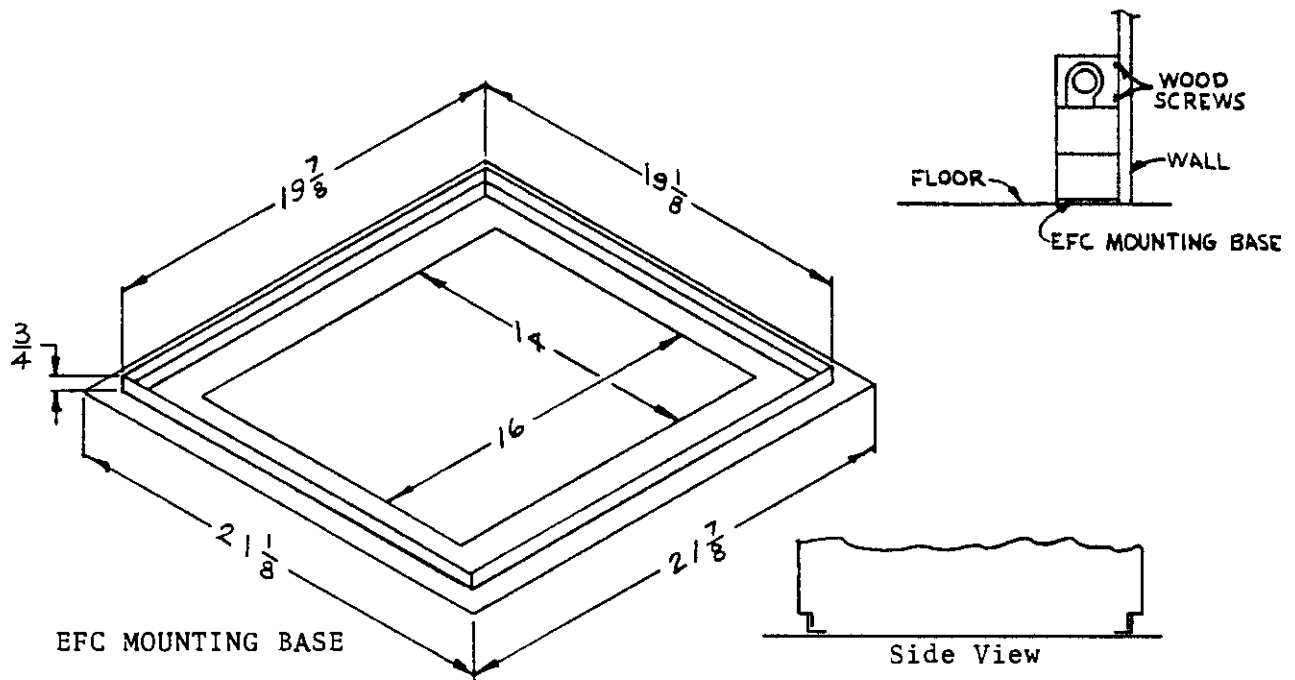
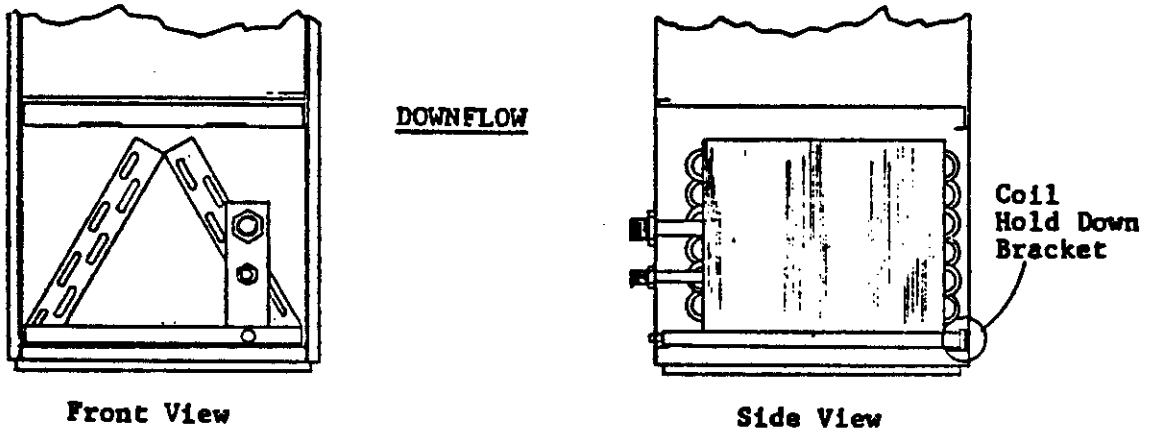
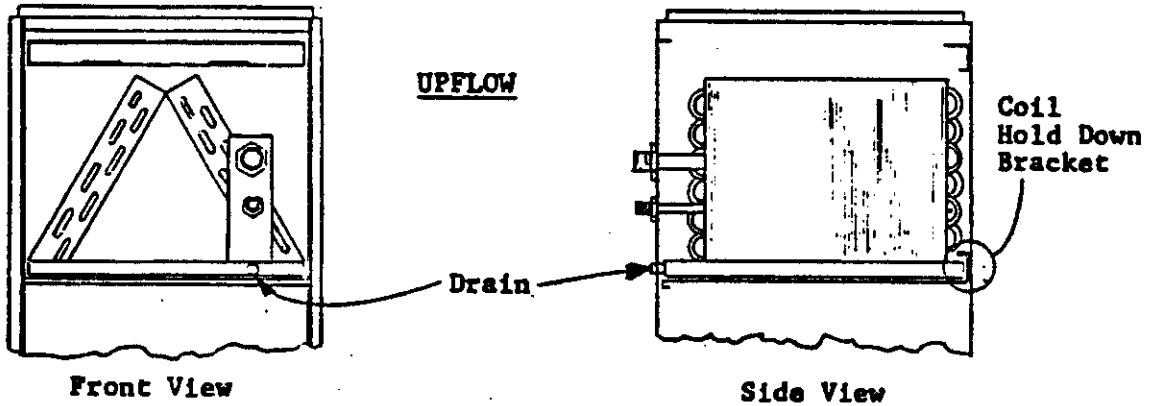

Figure A

ELECTRIC FURNACE EVAPORATOR COIL INSTALLATION



HORIZONTAL

NOTE:
Place "A" coil assembly in auxiliary water pan and slide into cabinet. When sliding into cabinet make sure that the pan is secured by the coil hold down brackets. This will prevent the "A" coil from dropping down.

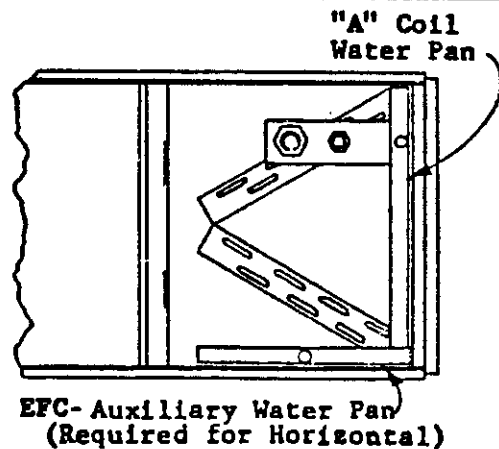

Figure B

PARTS LIST
ELECTRIC FURNACES

3/87

| Part No. | Description | EFC10-1 | EFC10-1-B | EFC15-1 | EFC20-1 | EFC25-1 | EFC30-1 |
|----------|-----------------------|---------|-----------|---------|---------|---------|---------|
| * | Blower Housing 10-8 | x | | | | | |
| * | Blower Housing 10-7 | | x | x | x | | |
| * | Blower Housing 10-9 | | | | | x | x |
| 5152-005 | Blower Wheel DD9-8A | x | | | | | |
| 5152-010 | Blower Wheel DD10-7A | | x | x | x | | |
| 5152-014 | Blower Wheel DD10-9A | | | | | x | x |
| 1171-011 | Cabinet Latch | (2) | (2) | (2) | (2) | (2) | (2) |
| 8552-001 | Capacitor 4/370V | | x | x | x | | |
| 8552-002 | Capacitor 5/370V | | | | | x | x |
| 8401-006 | Contactor | (1) | (1) | (2) | (1) | (3) | (2) |
| 8401-002 | Contactor | | | | x | | x |
| 1171-002 | Door Pull | x | x | x | x | x | x |
| 7004-001 | Filter 10x20 | (2) | | | | | |
| 7003-001 | Filter 10x20 P | | (2) | (2) | (2) | (2) | (2) |
| 8614-007 | Fuse 60A | | | (2) | (4) | (4) | (6) |
| 8614-006 | Fuse 30A | | | (2) | | (2) | |
| 8614-017 | Fuse Block 15Kw | | | x | | | |
| 8614-013 | Fuse Block 20Kw | | | | x | | |
| 8614-014 | Fuse Block 25Kw | | | | | x | |
| 8614-019 | Fuse Block 30Kw | | | | | | x |
| 8604-014 | Heat Strip 10Kw | x | x | | (2) | x | |
| 8604-015 | Heat Strip 15Kw | | | | | x | (2) |
| 8402-015 | Limit Switch L130-2.0 | (2) | (2) | (3) | (4) | (5) | (6) |
| 8102-003 | Motor 1/6 hp | x | | | | | |
| 8105-012 | Motor 1/3 hp | | x | x | x | | |
| 8105-010 | Motor 1/3 hp | | | | | x | x |
| 8200-003 | Motor Mount | x | x | x | x | x | x |
| 5451-011 | Motor Mounting Parts | x | x | x | x | x | x |
| 8201-014 | Relay - Blower | x | x | x | x | x | x |
| 8607-006 | Terminal Board 24V | x | x | x | x | x | x |
| 8607-013 | Terminal Block 230V | x | x | | | | |
| 8402-018 | Thermal Cutoff | (2) | (2) | (3) | (4) | (5) | (6) |
| 8407-034 | Transformer | x | x | x | | | |
| 8407-035 | Transformer | | | | x | x | x |
| 4016-130 | Wiring Diagram | x | | | | | |
| 4016-131 | Wiring Diagram | | x | | | | |
| 4016-140 | Wiring Diagram | | | x | | | |
| 4016-150 | Wiring Diagram | | | | x | | |
| 4016-160 | Wiring Diagram | | | | | x | |
| 4016-170 | Wiring Diagram | | | | | | x |

Please order by model number.
Minimum net billing \$15.00. Supersedes all previous lists.
Subject to change without notice.

T87F or 1F56
Indoor Thermostat

⚠ Add jumper wire on T87F only.
Set heat anticipator at .40A.

⚠ For 208V operation move this
wire to 208V transformer tap.

| MOTOR SPEED | |
|-------------|-------|
| Yellow | - Com |
| Red | - Lo |
| Black | - Hi |

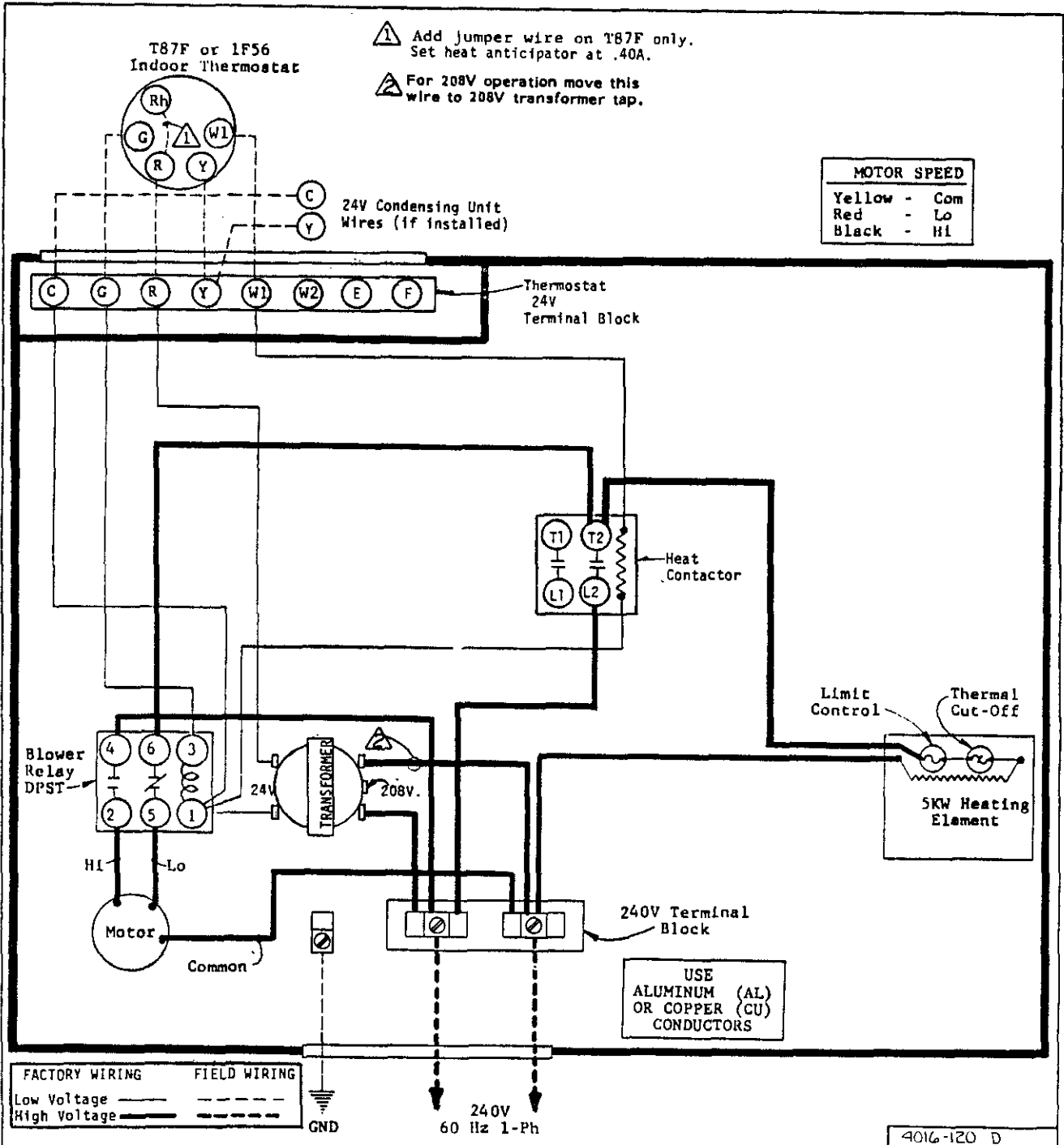

FACTORY WIRING FIELD WIRING
 Low Voltage ———
 High Voltage - - - -

GND

240V
60 Hz 1-Ph

USE
ALUMINUM (AL)
OR COPPER (CU)
CONDUCTORS

4016-120 D

T87F or 1F56
Indoor Thermostat



- ⚠ Add jumper wire on T87F only. Set heat anticipator at .40A.
- ⚠ For 208V operation move this wire to 208V transformer tap.

| MOTOR SPEED | |
|-------------|-------|
| Yellow | - Com |
| Red | - Lo |
| Black | - HI |

C 24V Condensing Unit
Y Wires (if installed)

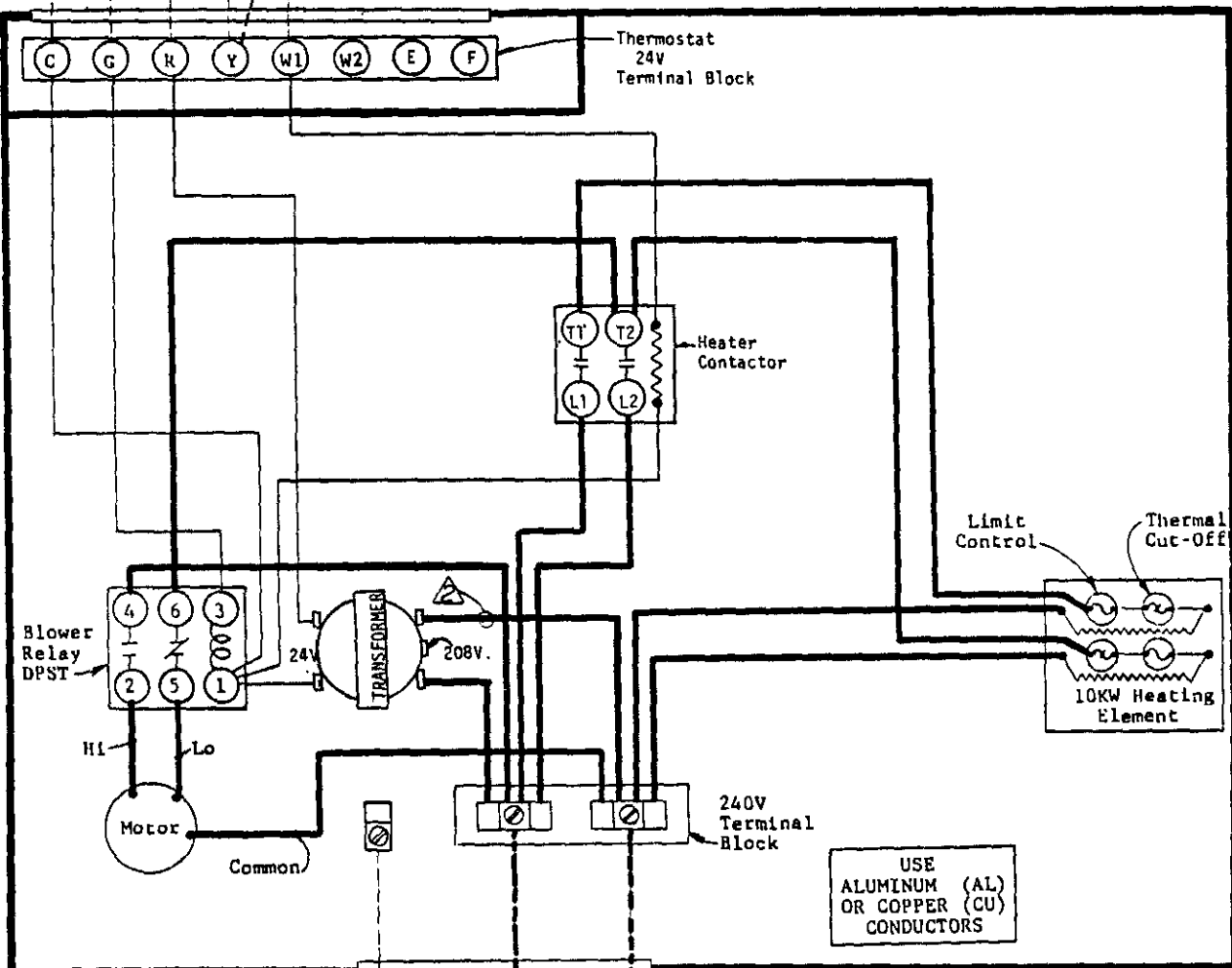

USE
ALUMINUM (AL)
OR COPPER (CU)
CONDUCTORS

| FACTORY WIRING | FIELD WIRING |
|------------------------|------------------------|
| Low Voltage ——— | Low Voltage ——— |
| High Voltage - - - - - | High Voltage - - - - - |

GND
240V
60 Hz 1-Ph

T87F or 1F56
Indoor Thermostat

- ⚠ Add jumper wire on T87F only. Set heat anticipator at .40A.
- ⚠ For 208V operation move this wire to 208V transformer tap.

| MOTOR SPEED | |
|-------------|-------------|
| Yellow | - Common |
| Brown | - Capacitor |
| Red | - Lo |
| Blue | - Med |
| Black | - HI |

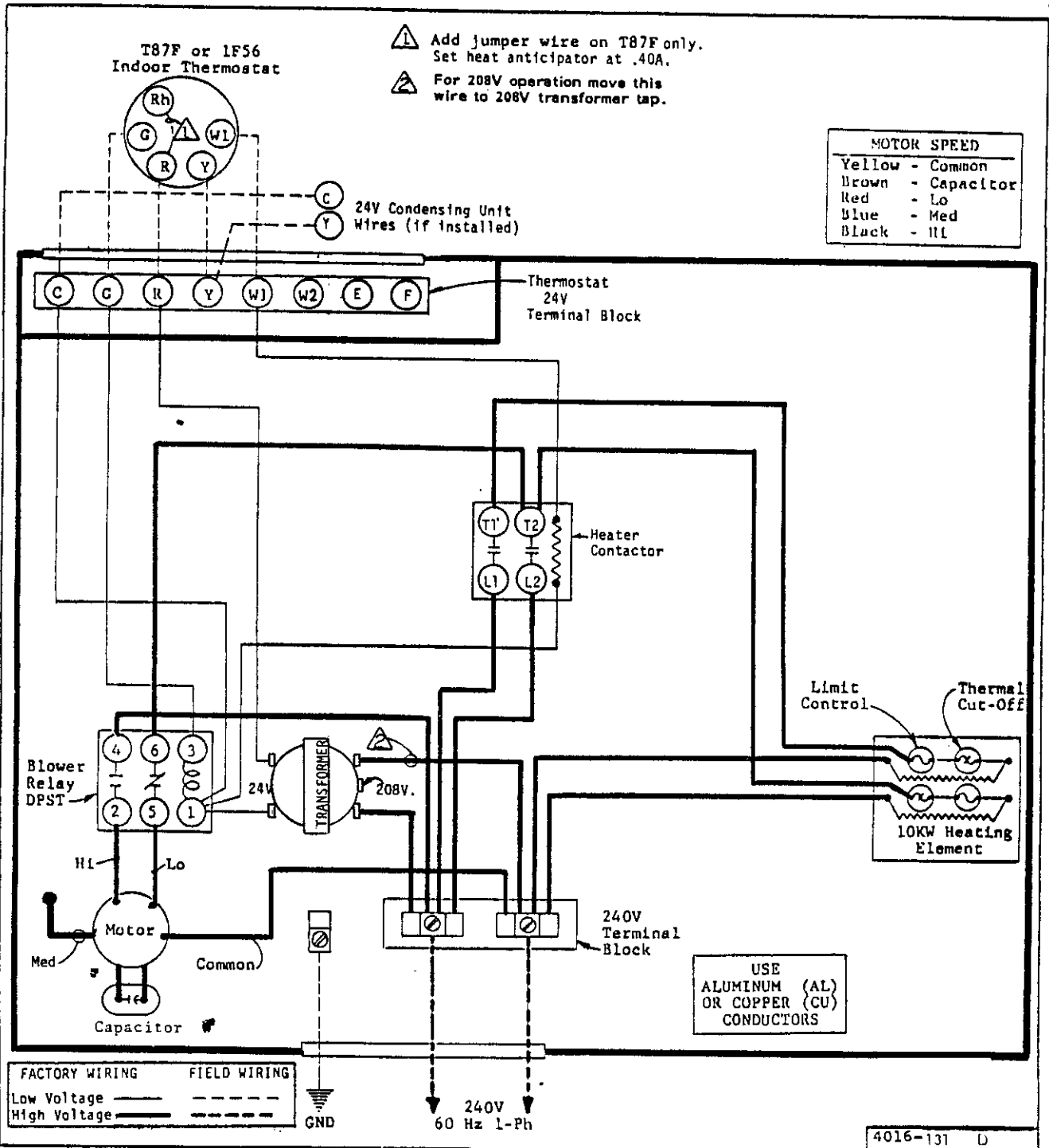

| FACTORY WIRING | FIELD WIRING |
|----------------|--------------|
| Low Voltage | ----- |
| High Voltage | ----- |

USE ALUMINUM (AL) OR COPPER (CU) CONDUCTORS

T87F 1F56
Indoor Thermostat

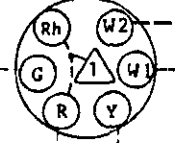

- 1 Add jumper wire on T87F only. Set heat anticipator at .80A.
- 2 For 2-stage operation, use T874C1000/Q674A1001. Remove jumper W1-W2 and connect W2-W2 as shown. Set heat anticipator at .40A each stage.
- 3 For 208V operation move this wire to 208V transformer tap.

24V Condensing Unit Wires (if installed)

| MOTOR SPEED | |
|-------------|-------------|
| Yellow | - Common |
| Brown | - Capacitor |
| Red | - Lo |
| Blue | - Med |
| Black | - HI |

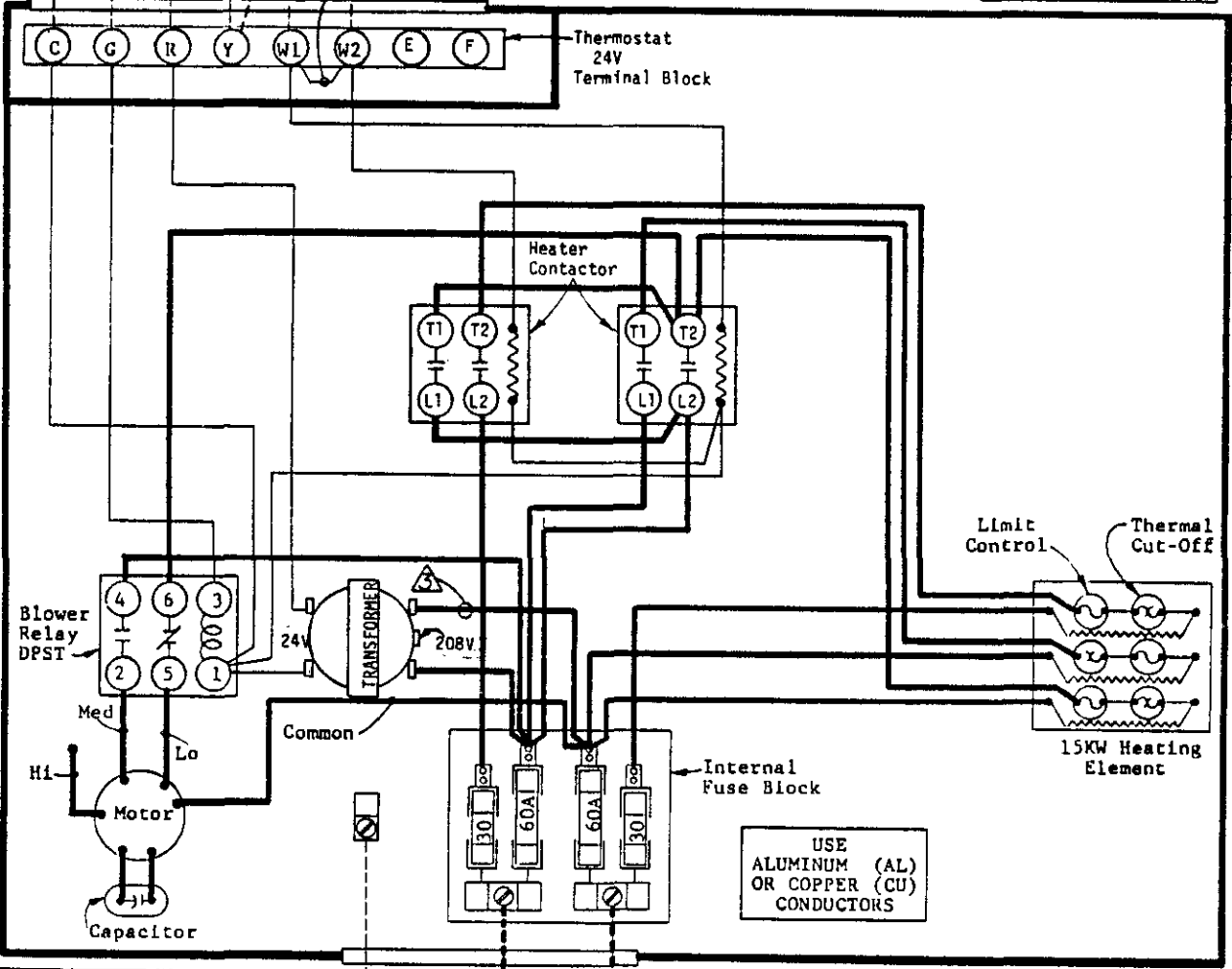

FACTORY WIRING Low Voltage High Voltage
FIELD WIRING Low Voltage High Voltage

GND 240V 60 Hz 1-Ph

USE ALUMINUM (AL) OR COPPER (CU) CONDUCTORS

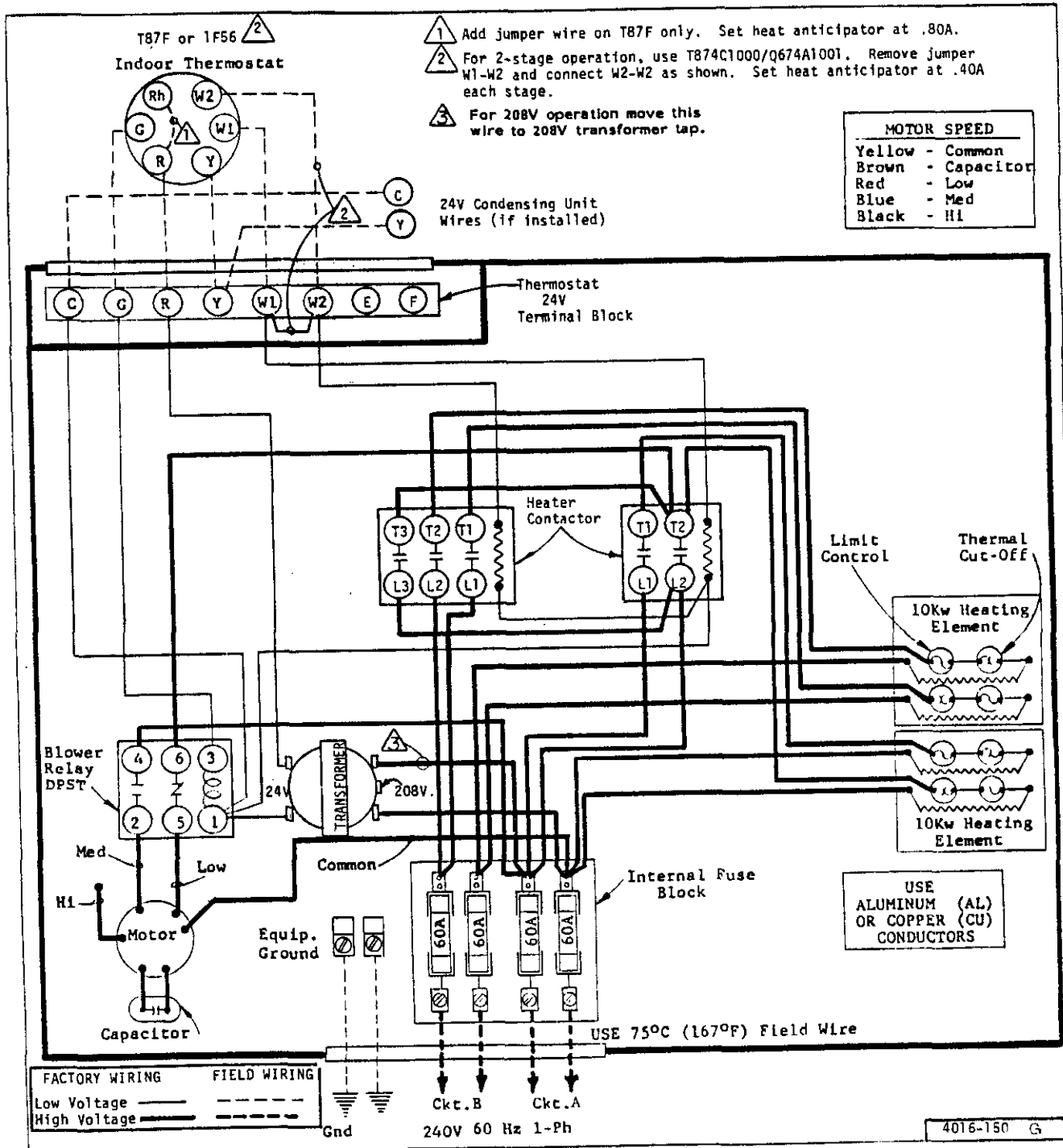

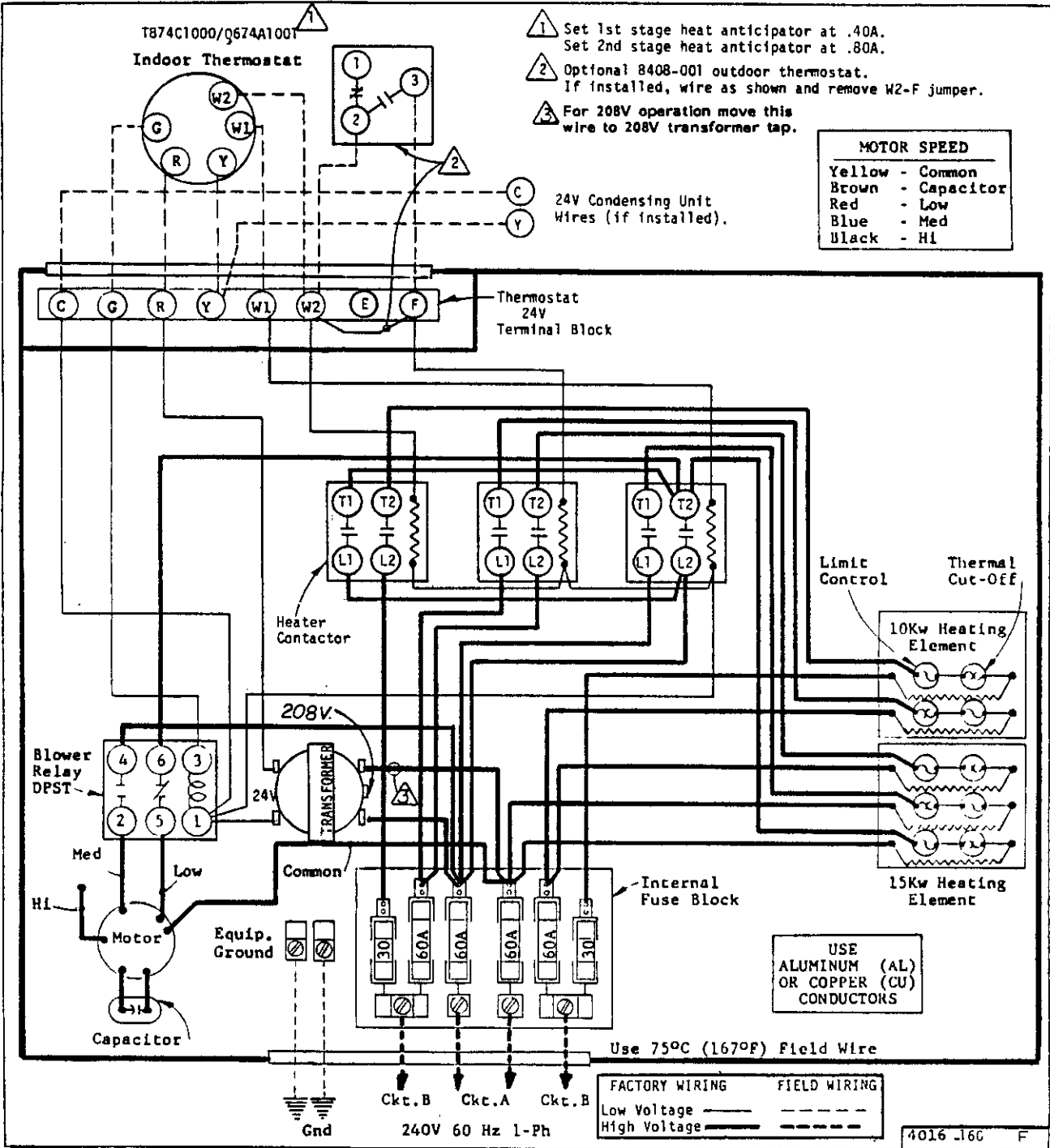

- 1 Set 1st stage heat anticipator at .40A. Set 2nd stage heat anticipator at .80A.
- 2 Optional 8408-001 outdoor thermostat. If installed, wire as shown and remove W2-F jumper.
- 3 For 208V operation move this wire to 208V transformer tap.

| MOTOR SPEED | |
|-------------|-------------|
| Yellow | - Common |
| Brown | - Capacitor |
| Red | - Low |
| Blue | - Med |
| Black | - HI |

24V Condensing Unit Wires (if installed).
C Y

USE ALUMINUM (AL) OR COPPER (CU) CONDUCTORS

