INSTALLATION INSTRUCTIONS

WALL MOUNTED PACKAGED AIR CONDITIONER

Models:

W17A2-A	W36A2-A	W48A2-A	W17L2-A	W42L2-A	W30A2DA
W18A2-A	W36A2-B	W48A2-B	W18L2-A	W42L2-B	W30A2DB
W24A2-A	W36A2-C	W48A2-C	W24L2-A	W42L2-C	W30A2DC
W24A2-B	W36A2-D	W48A2-E	W24L2-B	W42L2-F	W36A2DA
W24A2-C	W36A2-E	W48A2-F	W24L2-F	W48L2-A	W36A2DB
W24A2-D	W36A2-F	W60A2-A	W30L2-A	W48L2-B	W36A2DC
W24A2-F	W42A2-A	W60A2-B	W30L2-B	W48L2-C	W42A2DA
W30A2-A	W42A2-B	W60A2-C	W30L2-C	W48L2-F	W42A2DB
W30A2-B	W42A2-C	W60A2-E	W36L2-A	W60L2-A	W42A2DC
W30A2-C	W42A2-E	W60A2-F	W36L2-B	W60L2-B	W48A2DA
W30A2-D	W42A2-F	W70A2-A	W36L2-C	W60L2-C	W48A2DB
W30A2-F		W70A2-B	W36L2-F	W60L2-F	W48A2DC
		W70A2-C		W70L2-A	W60A2DA
		W70A2-F		W70L2-B	W60A2DB
				W70L2-C	W60A2DC
				W70L2-F	



Bard Manufacturing Company, Inc.
Bryan, Ohio 43506
www.bardhvac.com

Manual: 2100-581D
Supersedes: 2100-581C
Date: 7-21-16

CONTENTS

Getting Other Information and Publications 3

Wall Mount General Information 4

Air Conditioner Wall Mount Model Nomenclature	4
Shipping Damage	4
General	4
Duct Work	5
Filters	5
Fresh Air Intake	5
Condensate Drain	5

Installation 6

Wall Mounting Information	6
Mounting the Unit	6
Clearances Required	6
Minimum Clearances	6
Wiring – Main Power	14
Wiring – Low Voltage	14

Figures

Figure 1 Fresh Air Damper Assembly	5
Figure 2 Unit Dimensions	7
Figure 3A Mounting Instructions – W17, 18, 24	8
Figure 3B Mounting Instructions – W30, 36	9
Figure 3C Mounting Instructions – W42, 48, 60, 70 ..	10
Figure 4 Electric Heat Clearance	11
Figure 5 Wall Mounting Instructions	12
Figure 6 Wall Mounting Instructions	12
Figure 7 Common Wall Mounting Installations	13
Figure 8 Fan Blade Setting	18

Start Up 15

General	15
Topping Off System Charge	15
Safety Practices	15
Important Installer Note	16
High Pressure Switch	16
Three Phase Scroll Compressor	16
Phase Monitor	16
Condenser Fan Operation	16
Service Hints	16
Sequence of Operation	16
Compressor Control Module	17
Pressure Service Ports	17

Service 18

Fan Blade Setting Dimensions	18
R-410A Refrigerant Charge	18
Removal of Fan Shroud	18

Tables

Table 1 Fan Blade Dimensions	18
Table 2 Cooling Pressure	19
Table 3 Electrical Specifications W**A	20
Table 4 Electrical Specifications W**L	21
Table 5 Recommended Airflow	22
Table 6 Indoor Blower Performance	22
Table 7 Maximum ESP Electric Heat Only	22
Table 8 Electric Heat	23
Table 9A Optional Accessories – Right Hand	24
Table 9B Optional Accessories – Left Hand	25
Table 10 Vent and Control Options	26

GETTING OTHER INFORMATION AND PUBLICATIONS

These publications can help when installing the furnace. They can usually be found at the local library or purchased directly from the publisher. Be sure to consult the current edition of each standard.

National Electrical CodeANSI/NFPA 70

Standard for the InstallationANSI/NFPA 90A
of Air Conditioning and Ventilating Systems

Standard for Warm Air.....ANSI/NFPA 90B
Heating and Air Conditioning Systems

Load Calculation for ACCA Manual J
Residential Winter and Summer Air Conditioning

Duct Design for Residential ACCA Manual D
Winter and Summer Air Conditioning and Equipment
Selection

For more information, contact these publishers:

ACCA **Air Conditioning Contractors of America**
1712 New Hampshire Ave. N.W.
Washington, DC 20009
Telephone: (202) 483-9370
Fax: (202) 234-4721

ANSI **American National Standards Institute**
11 West Street, 13th Floor
New York, NY 10036
Telephone: (212) 642-4900
Fax: (212) 302-1286

ASHRAE **American Society of Heating, Refrigeration
and Air Conditioning Engineers, Inc.**
1791 Tullie Circle, N.E.
Atlanta, GA 30329-2305
Telephone: (404) 636-8400
Fax: (404) 321-5478

NFPA **National Fire Protection Association**
Batterymarch Park
P.O. Box 9101
Quincy, MA 02269-9901
Telephone: (800) 344-3555
Fax: (617) 984-7057

WALL MOUNT GENERAL INFORMATION

AIR CONDITIONER WALL MOUNT MODEL NOMENCLATURE

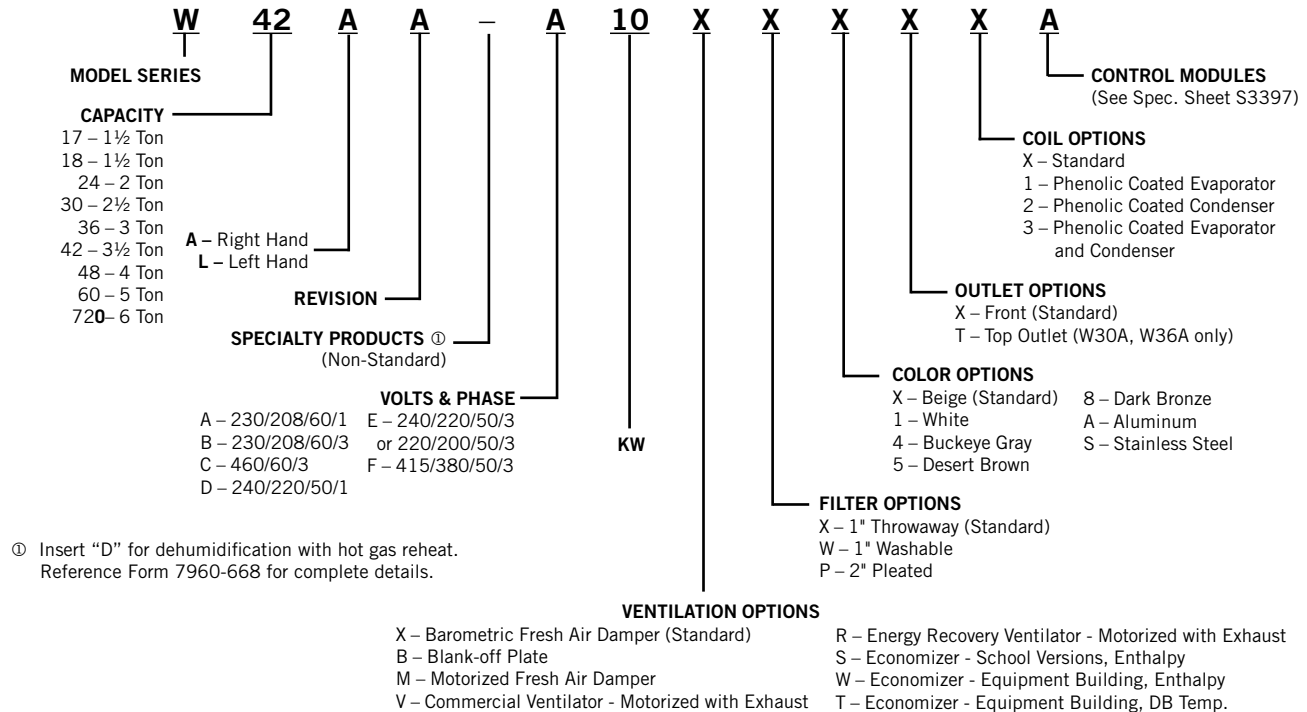

NOTE: Vent options X, B and M are without exhaust capability. May require separate field-supplied barometric relief in building.

SHIPPING DAMAGE

Upon receipt of equipment, the carton should be checked for external signs of shipping damage. If damage is found, the receiving party must contact the last carrier immediately, preferably in writing, requesting inspection by the carrier's agent.

GENERAL

The equipment covered in this manual is to be installed by trained, experienced service and installation technicians.

This appliance is not intended for use by persons (including children) with reduced physical, sensory or mental capabilities, or lack of experience and knowledge, unless they have been given supervision or instruction concerning use of the appliance by a person responsible for their safety.

Children should be supervised to ensure that they do not play with the appliance.

The refrigerant system is completely assembled and charged. All internal wiring is complete.

The unit is designed for use with or without duct work. Flanges are provided for attaching the supply and return ducts.

These instructions explain the recommended method to install the air cooled self-contained unit and the electrical wiring connections to the unit.

These instructions and any instructions packaged with any separate equipment required to make up the entire air conditioning system should be carefully read before beginning the installation. Note particularly "Starting Procedure" and any tags and/or labels attached to the equipment.

While these instructions are intended as a general recommended guide, they do not supersede any national and/or local codes in any way. Authorities having jurisdiction should be consulted before the installation is made. See Page 3 for information on codes and standards.

Size of unit for a proposed installation should be based on heat loss calculation made according to methods of Air Conditioning Contractors of America (ACCA). The air duct should be installed in accordance with the Standards of the National Fire Protection Association for the Installation of Air Conditioning and Ventilating Systems of Other Than Residence Type, NFPA No. 90A, and Residence Type Warm Air Heating and Air Conditioning Systems, NFPA No. 90B. Where local regulations are at a variance with instructions, installer should adhere to local codes.

DUCT WORK

All duct work, supply and return, must be properly sized for the design airflow requirement of the equipment. Air Conditioning Contractors of America (ACCA) is an excellent guide to proper sizing. All duct work or portions thereof not in the conditioned space should be properly insulated in order to both conserve energy and prevent condensation or moisture damage.

Refer to Maximum ESP of operation Electric Heat Table 7.

Design the duct work according to methods given by the Air Conditioning Contractors of America (ACCA). When duct runs through unheated spaces, it should be insulated with a minimum of one inch of insulation. Use insulation with a vapor barrier on the outside of the insulation. Flexible joints should be used to connect the duct work to the equipment in order to keep the noise transmission to a minimum.

Models W17 – W24 are approved for 0" clearance to the supply duct. For model series W30, W36, W42, W48, W60 and W70, a 1/4" clearance to combustible material for the first 3' of duct attached to the outlet air frame is required. See Wall Mounting Instructions and Figures 3 and 4 for further details.

Ducts through the walls must be insulated and all joints taped or sealed to prevent air or moisture entering the wall cavity.

Some installations may not require any return air duct. A metallic return air grille is required with installations not requiring a return air duct. The spacing between louvers on the grille shall not be larger than 5/8".

Any grille that meets with 5/8" louver criteria may be used. It is recommended that Bard Return Air Grille Kit RG2 through RG5 or RFG2 through RFG5 be installed when no return duct is used. Contact distributor or factory for ordering information. If using a return air filter grille, filters must be of sufficient size to allow a maximum velocity of 400 fpm.

NOTE: If no return air duct is used, applicable installation codes may limit this cabinet to installation only in a single story structure.

FILTERS

A 1" throwaway filter is standard with each unit. The filter slides into position making it easy to service. This filter can be serviced from the outside by removing the filter access panel. A 1" washable filter and 2" pleated filter are also available as optional accessories. The internal filter brackets are adjustable to accommodate the 2" filter by bending two (2) tabs down on each side of the filter support bracket.

FRESH AIR INTAKE

All units are built with fresh air inlet slots punched in the service door.

If the unit is equipped with a fresh air damper assembly, the assembly is shipped already attached to the unit. The damper blade is locked in the closed position. To allow the damper to operate, the maximum and minimum blade position stops must be installed (see Figure 1).

All capacity, efficiency and cost of operation information is based upon the fresh air blank-off plate in place and is recommended for maximum energy efficiency.

The blank-off plate is available upon request from the factory and is installed in place of the fresh air damper shipped with each unit.

CONDENSATE DRAIN

A plastic drain hose extends from the drain pan at the top of the unit down to the unit base. There are openings in the unit base for the drain hose to pass through. In the event the drain hose is connected to a drain system of some type, it must be an open or vented type system to assure proper drainage.

FIGURE 1
Fresh Air Damper Assembly

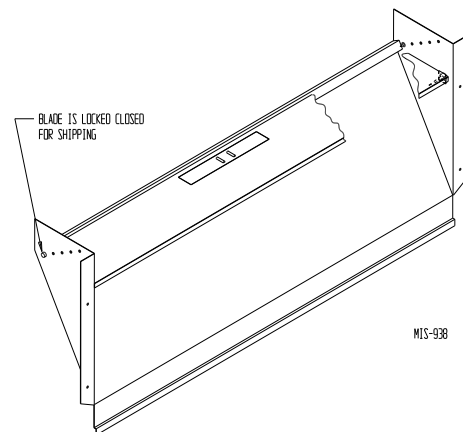

INSTALLATION

WALL MOUNTING INFORMATION

1. Two holes for the supply and return air openings must be cut through the wall as shown in Figure 3.
2. On wood frame walls, the wall construction must be strong and rigid enough to carry the weight of the unit without transmitting any unit vibration.
3. Concrete block walls must be thoroughly inspected to insure that they are capable of carrying the weight of the installed unit.

WARNING

Failure to provide the 1/4" clearance between the supply duct and a combustible surface for the first 3' of duct can result in fire causing damage, injury or death.

MOUNTING THE UNIT

1. These units are secured by wall mounting brackets which secure the unit to the outside wall surface at both sides. A bottom mounting bracket, attached to skid for shipping, is provided for ease of installation, but is not required.
2. The unit itself is suitable for 0" clearance, but the supply air duct flange and the first 3' of supply air duct require a minimum of 1/4" clearance to combustible material for model series W30, W36, W42, W48, W60 and W70. However, it is generally recommended that a 1" clearance is used for ease of installation and maintaining the required clearance to combustible material. See Figure 3 for details on opening sizes.
3. Locate and mark lag bolt locations and bottom mounting bracket location (see Figure 3).
4. Mount bottom mounting bracket.
5. Hook top rain flashing, attached to front-right of supply flange for shipping, under back bend of top.
6. Position unit in opening and secure with 5/16" lag bolts; use 7/8" diameter flat washers on the lag bolts.
7. Secure rain flashing to wall and caulk across entire length of top (see Figure 3).
8. For additional mounting rigidity, the return air and supply air frames or collars can be drilled and screwed or welded to the structural wall itself (depending upon wall construction). Be sure to observe required clearance if combustible wall.
9. On side-by-side installations, maintain a minimum of 20" clearance on right side to allow access to control panel and heat strips, and to allow proper airflow to the outdoor coil. Additional clearance may be required to meet local or national codes.

Clearances Required for Service Access and Adequate Condenser Airflow

MODELS	LEFT SIDE	RIGHT SIDE	DISCHARGE SIDE
W17A, W18A, W24A, W30A, W36A	15"	20"	10'
W17L, W18L, W24L, W30L, W36L	20"	15"	10'
W42A, W48A, W60A, W70A	20"	20"	10'
W42L, W48L, W60L, W70L	20"	20"	10'

NOTE: For side by side installation of two (2) W**A models there must be 20" between units. This can be reduced to 15" by using a W**L model (left side compressor and controls) for the left unit and WA (right side compressor and controls) for right unit.

See W**A Specification S3397 & W**L Specification S3400.

Minimum Clearances Required to Combustible Materials

MODELS	SUPPLY AIR DUCT FIRST THREE FEET	CABINET
W17A, L / W18A, L / W24A, L	0"	0"
W30A, L / W36A, L	1/4"	0"
W42A, L / W48A, L / W60A, L / W70A, L	1/4"	0"

FIGURE 2

Dimensions of Basic Unit for Architectural and Installation Requirements (Nominal)

MODEL	WIDTH (W)	DEPTH (D)	HEIGHT (H)	SUPPLY		RETURN																
				A	B	C	B	E	F	G	I	J	K	L	M	N	O	P	Q	R	S	T
W17A, L W18A, L W24A, L	33.300	17.125	70.563	7.88	19.88	11.88	19.88	35.00	11.00	25.75	20.56	26.75	28.06	29.25	27.00	2.63	34.13	22.06	10.55	4.19	12.00	5.00
W30A, L W36A, L	38.200	17.125	70.563	7.88	27.88	13.88	27.88	40.00	11.00	25.75	17.93	26.75	28.75	29.25	27.00	2.75	39.19	22.75	9.14	4.19	12.00	5.00
W42A, L W48A, L W60A, L W70A, L	42.075	22.432	84.875	9.88	29.88	15.88	29.88	43.88	13.63	31.66	30.00	32.68	26.94	34.69	32.43	3.37	42.88	23.88	10.00	1.44	16.00	1.88

All dimensions are in inches. Dimensional drawings are not to scale.

WA
RIGHT
UNIT**

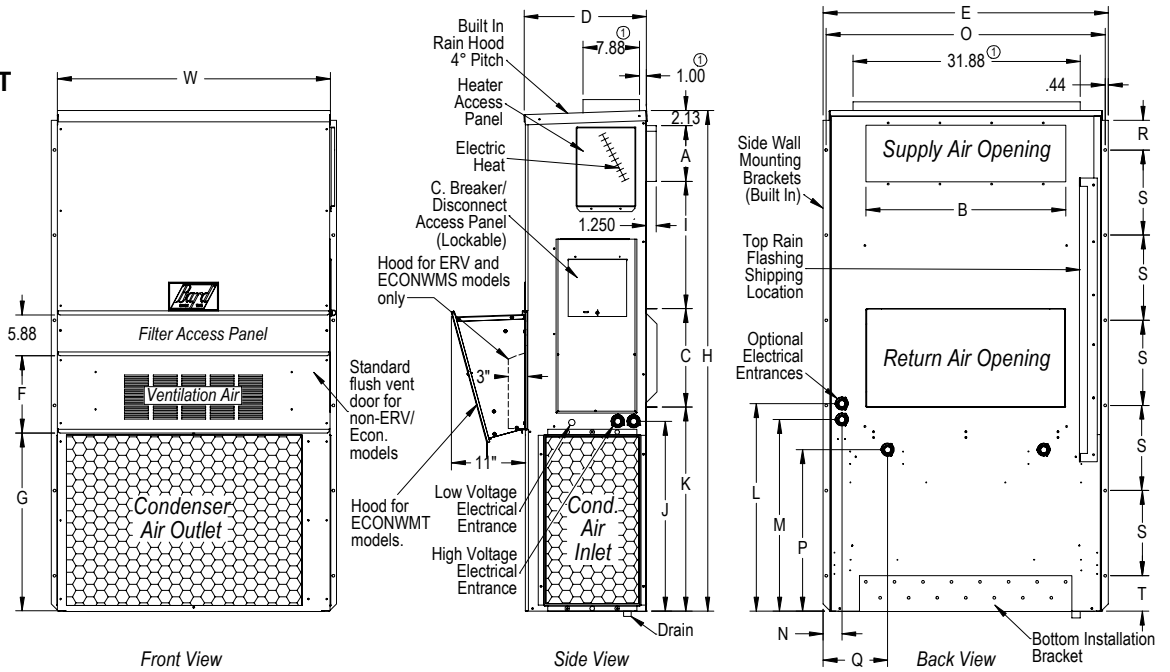

MIS-2487 H

① Optional top outlet (factory installed only) for W30A and W36A models only.

WL
LEFT
UNIT**

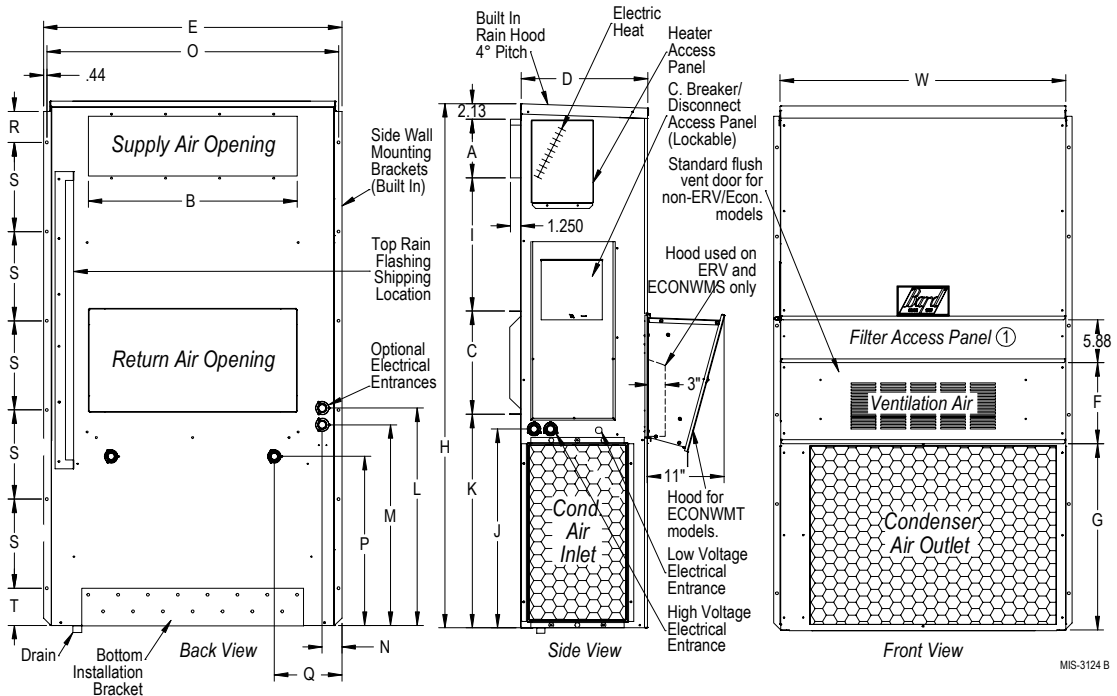

MIS-3124 B

FIGURE 3A
W17A2, W17L2, W18A2, W18L2, W24A2, W24L2
Mounting Instructions

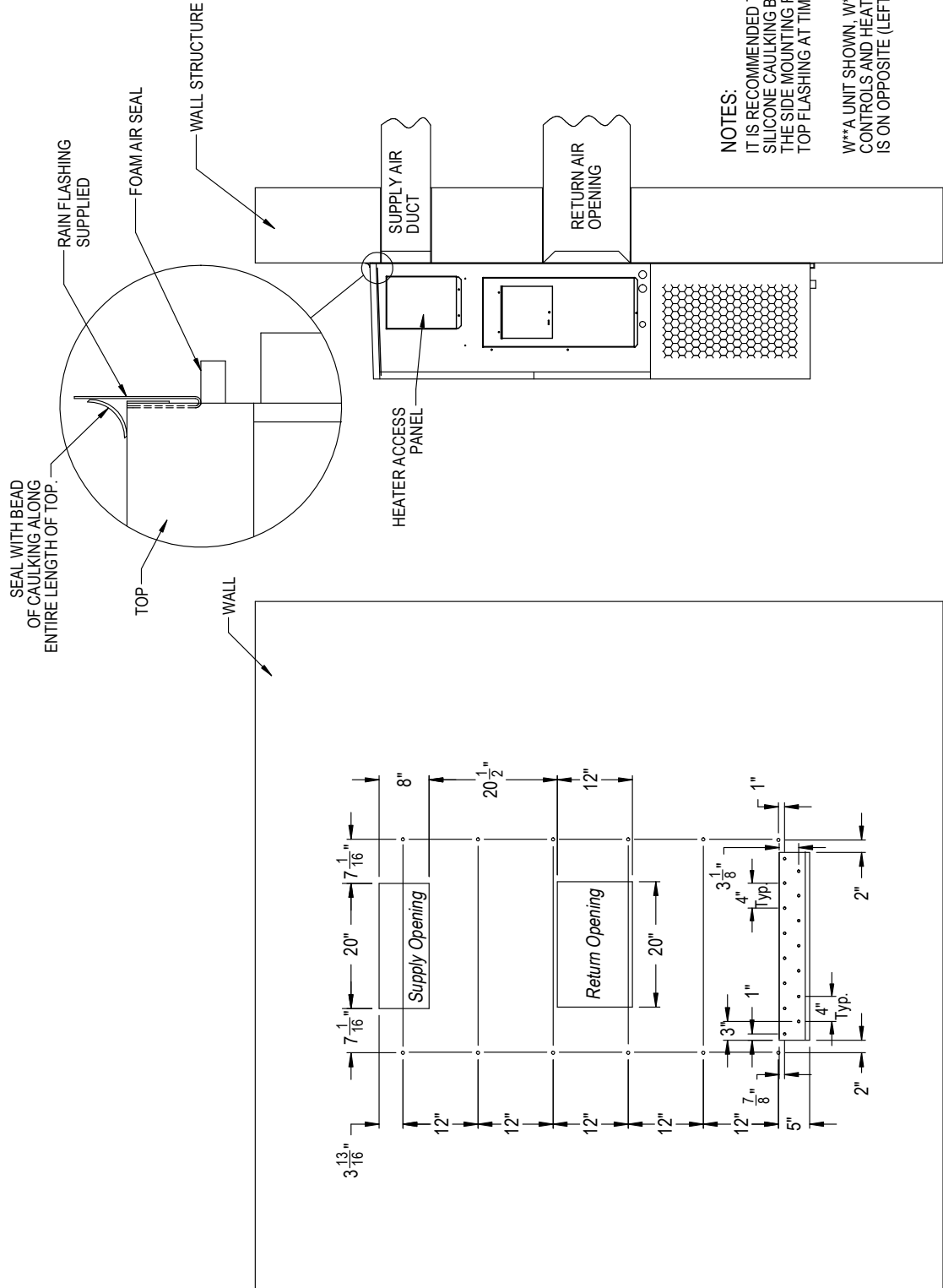

NOTES:
 IT IS RECOMMENDED THAT A BEAD OF SILICONE CAULKING BE PLACED BEHIND THE SIDE MOUNTING FLANGES AND UNDER TOP FLASHING AT TIME OF INSTALLATION.

W**A UNIT SHOWN. W**L UNIT CONTROLS AND HEATER ACCESS IS ON OPPOSITE (LEFT) SIDE.

Right Side View

Wall Opening and Hole Location View

MS-3157

FIGURE 3B
W30A2, W30L2, W36A2, W36L2
Mounting Instructions

	A	B	C	D	E
REQUIRED DIMENSIONS TO MAINTAIN 1/4" MIN. CLEARANCE FROM COMBUSTIBLE MATERIALS	28 3/8	8 3/8	5 3/8	3 11/16	17 5/8
REQUIRED DIMENSIONS TO MAINTAIN RECOMMENDED 1" CLEARANCE FROM COMBUSTIBLE MATERIALS	29 7/8	9 7/8	4 5/8	4 7/16	16 7/8

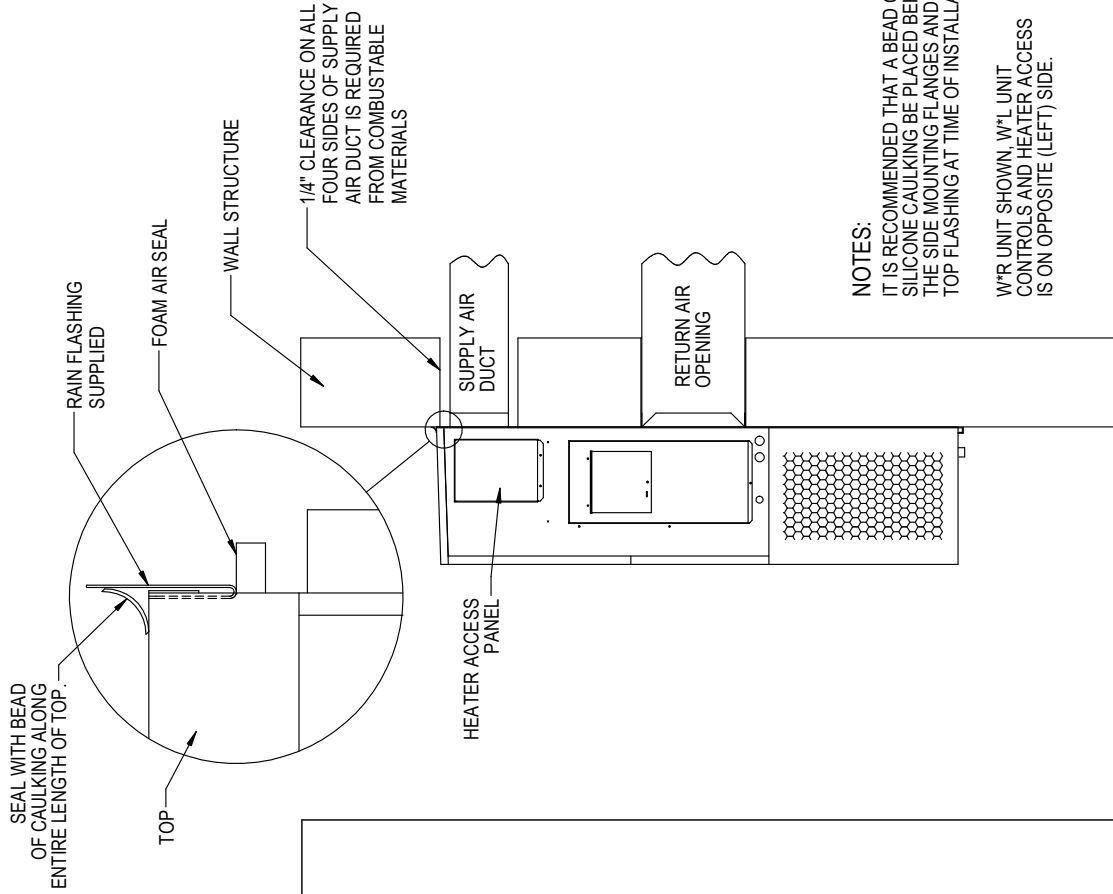

NOTES:
 IT IS RECOMMENDED THAT A BEAD OF SILICONE CAULKING BE PLACED BEHIND THE SIDE MOUNTING FLANGES AND UNDER TOP FLASHING AT TIME OF INSTALLATION.
 W/R UNIT SHOWN, W/L UNIT CONTROLS AND HEATER ACCESS IS ON OPPOSITE (LEFT) SIDE.

Right Side View

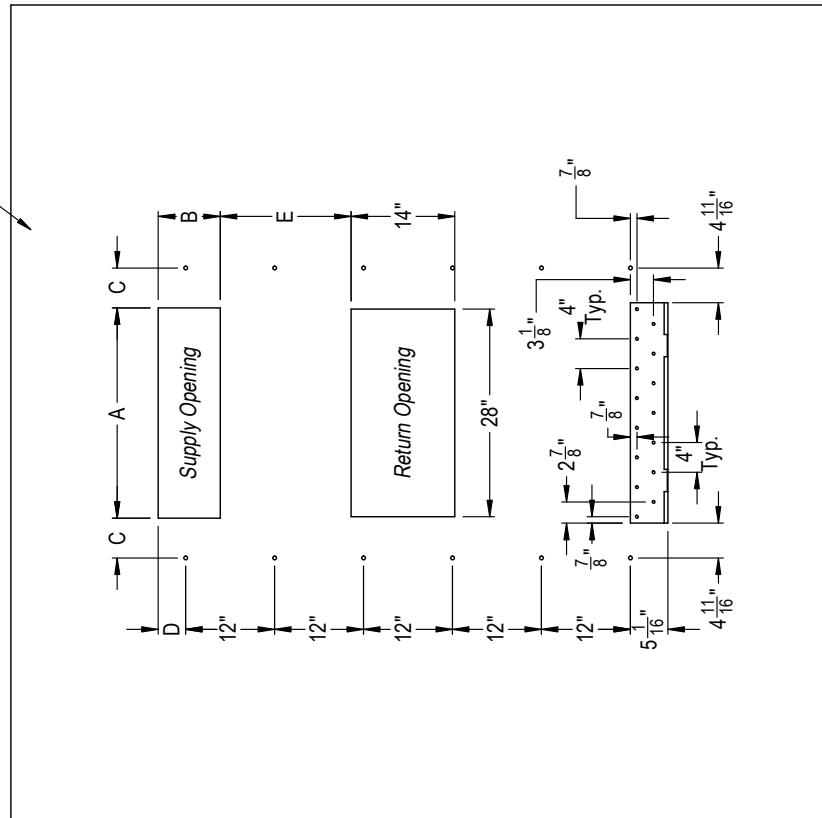

Wall Opening and Hole Location View

MIS-3168

FIGURE 3C
W42A2, W42L2, W48A2, W48L2, W60A2, W60L2, W70A2, W70L2
Mounting Instructions

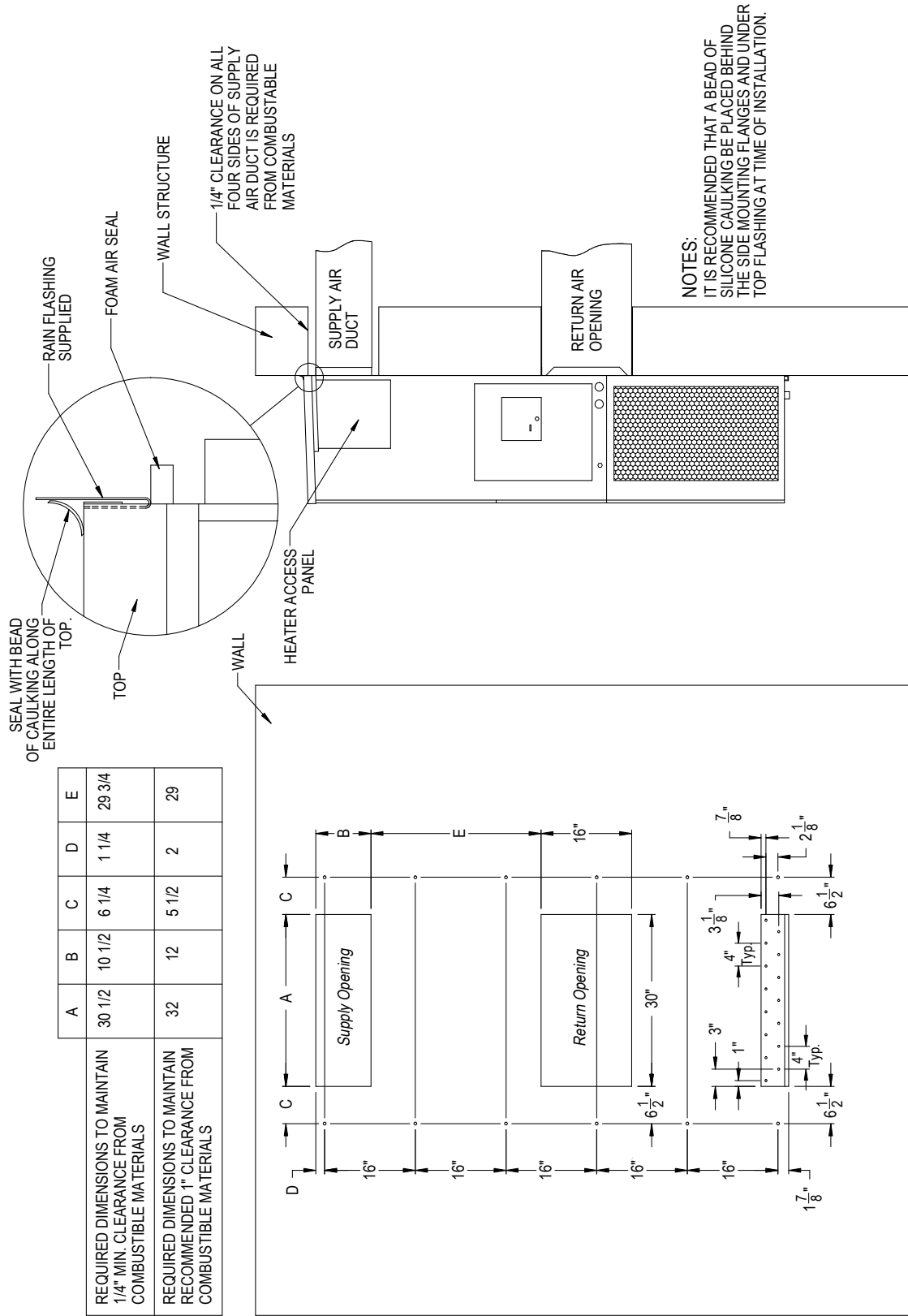

MIS-416 E

FIGURE 4
Electric Heat Clearance
W30A2, W30L2, W36A2, W36L2, W42A2, W42L2, W48A2, W48L2, W60A2, W60L2, W70A2, W70L2

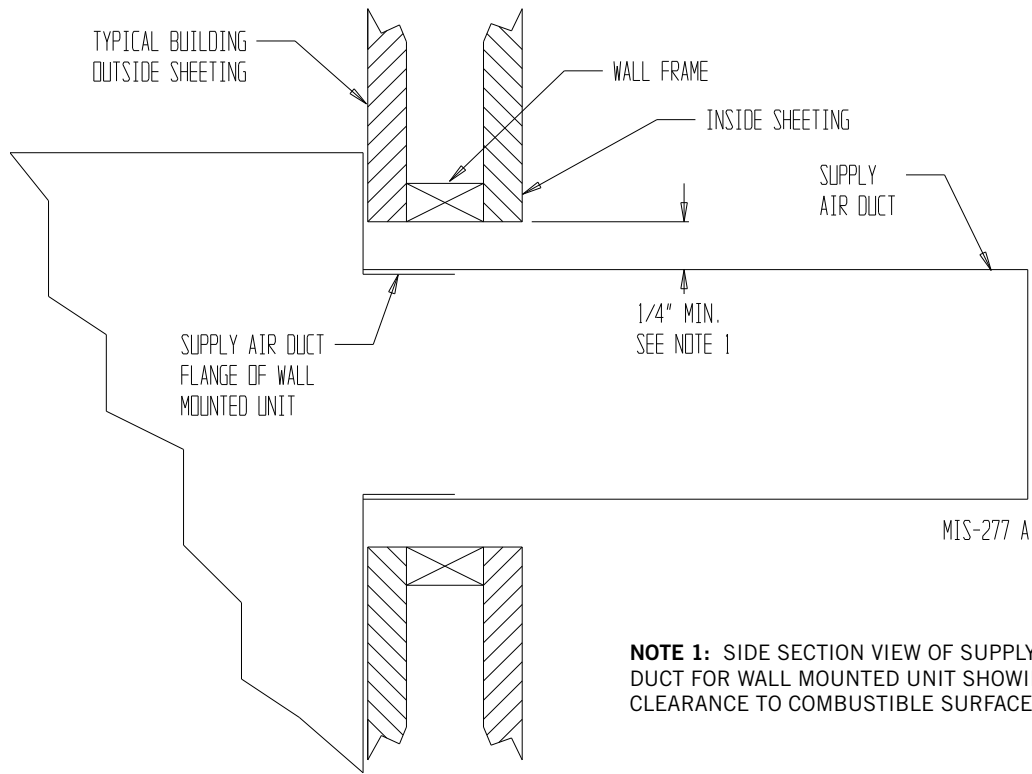

NOTE 1: SIDE SECTION VIEW OF SUPPLY AIR DUCT FOR WALL MOUNTED UNIT SHOWING 1/4" CLEARANCE TO COMBUSTIBLE SURFACES.

WARNING

A *minimum* of 1/4" clearance must be maintained between the supply air duct and combustible materials. This is required for the first 3' of ducting.

It is important to insure that the 1/4" minimum spacing is maintained at all points.

Failure to do this could result in overheating the combustible material and may result in a fire causing damage, injury or death.

FIGURE 5
Wall Mounting Instructions

SEE FIGURES 3A-C MOUNTING INSTRUCTIONS

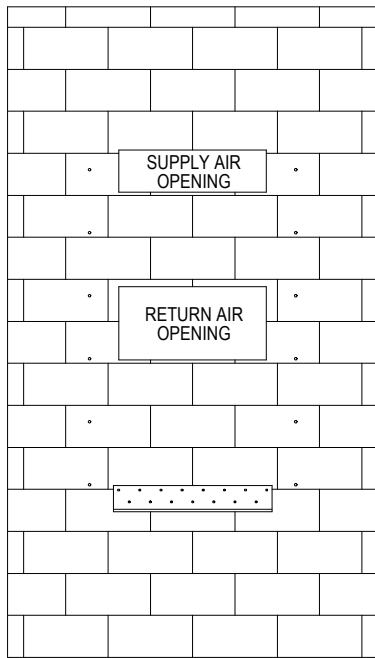

CONCRETE BLOCK WALL INSTALLATION

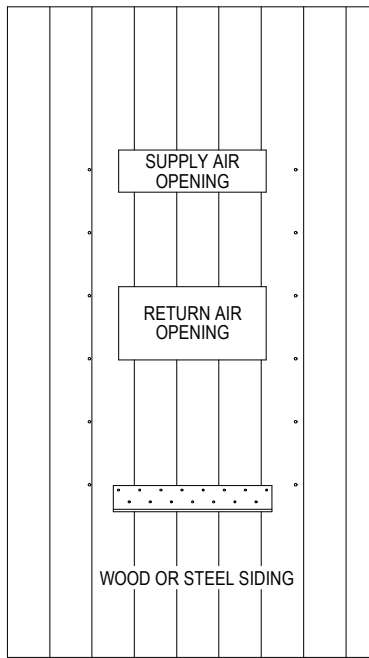

WOOD FRAME WALL INSTALLATION

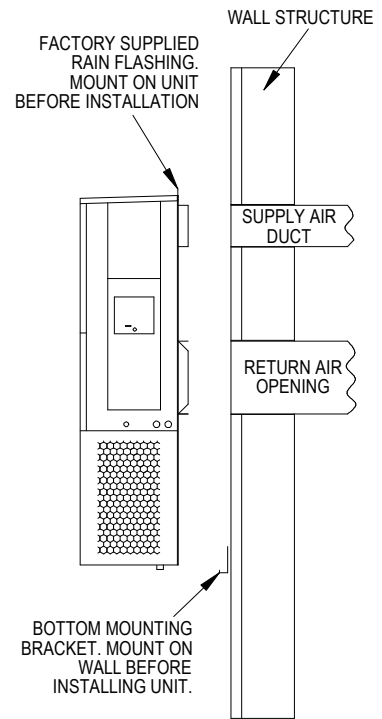

SIDE VIEW

MIS-548 A

FIGURE 6
Wall Mounting Instructions

SEE UNIT DIMENSIONS, FIGURE 2,
FOR ACTUAL DIMENSIONS.

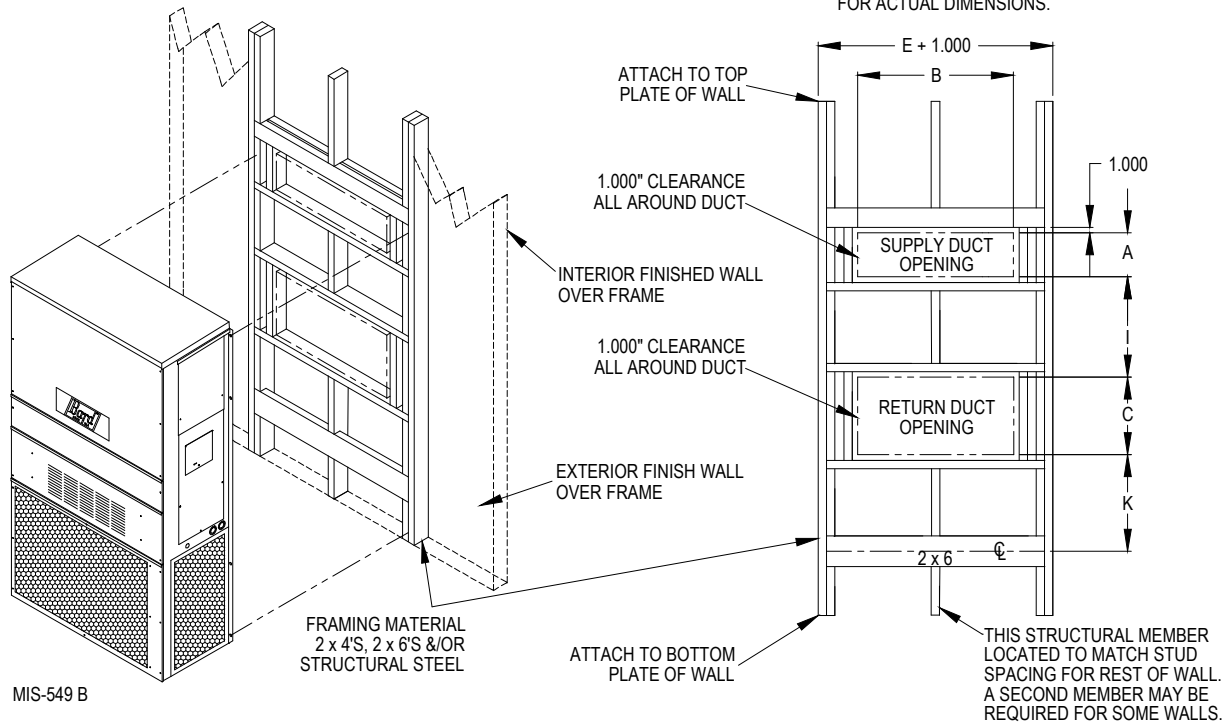

MIS-549 B

THIS STRUCTURAL MEMBER
LOCATED TO MATCH STUD
SPACING FOR REST OF WALL.
A SECOND MEMBER MAY BE
REQUIRED FOR SOME WALLS.

FIGURE 7
Common Wall Mounting Instructions

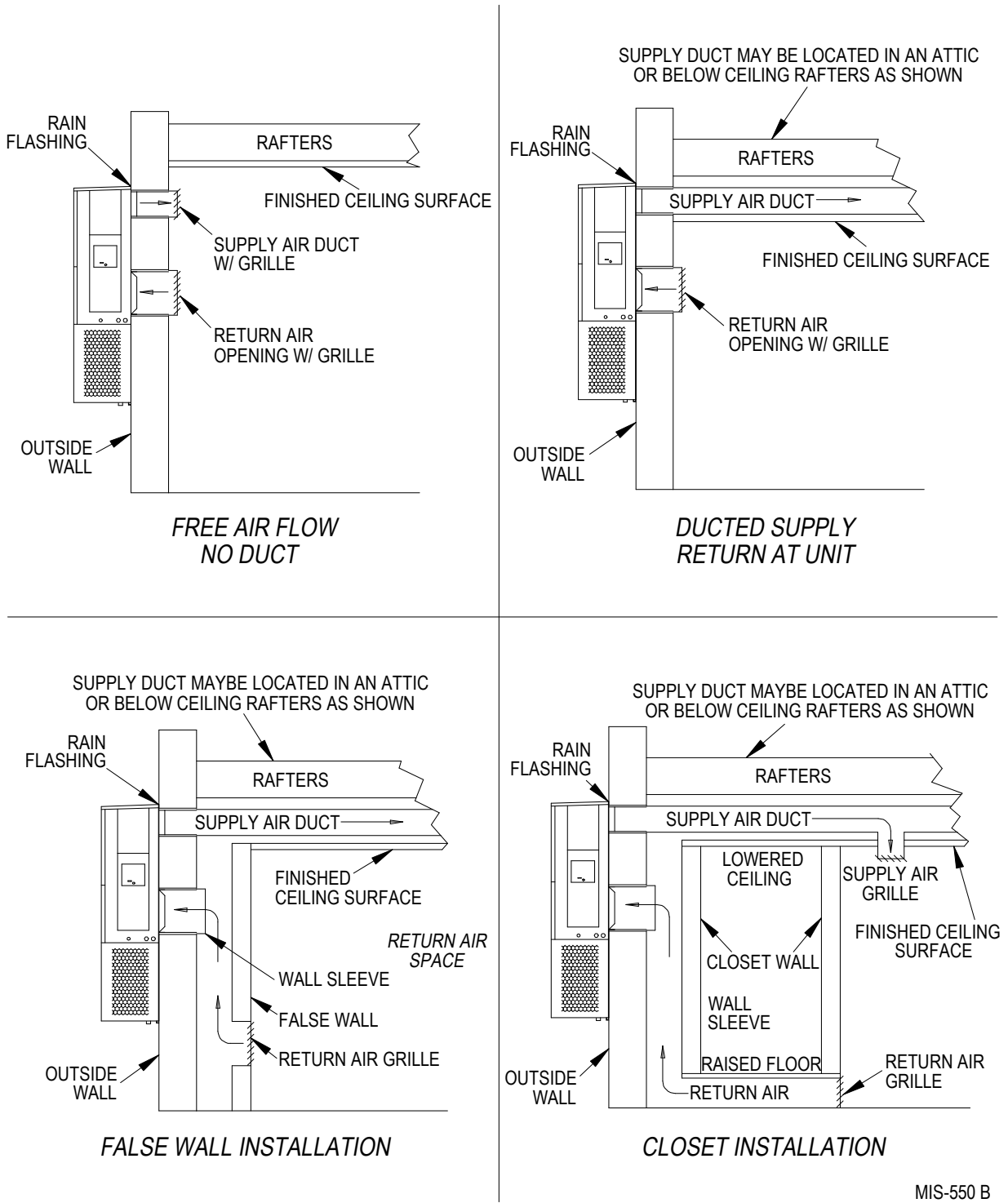

MIS-550 B

WIRING – MAIN POWER

Refer to the unit rating plate for wire sizing information and maximum fuse or circuit breaker size. Each outdoor unit is marked with a “Minimum Circuit Ampacity”. This means that the field wiring used must be sized to carry that amount of current. Depending on the installed KW of electric heat, there may be two field power circuits required. If this is the case, the unit serial plate will so indicate. All models are suitable only for connection with copper wire. Each unit and/or wiring diagram will be marked “Use Copper Conductors Only”. These instructions **must be** adhered to. Refer to the National Electrical Code (NEC) for complete current carrying capacity data on the various insulation grades of wiring material. All wiring must conform to NEC and all local codes.

The electrical data lists fuse and wire sizes (75°C copper) for all models including the most commonly used heater sizes. Also shown are the number of field power circuits required for the various models with heaters.

The unit rating plate lists a “Maximum Time Delay Relay Fuse” or circuit breaker that is to be used with the equipment. The correct size must be used for proper circuit protection and also to assure that there will be no nuisance tripping due to the momentary high starting current of the compressor motor.

The disconnect access door on this unit may be locked to prevent unauthorized access to the disconnect. To convert for the locking capability, bend the tab located in the bottom left-hand corner of the disconnect opening under the disconnect access panel straight out. This tab will now line up with the slot in the door. When shut, a padlock may be placed through the hole in the tab preventing entry.

See “Start Up” section for important information on three phase scroll compressor start ups.

See Tables 3 and 4 for Electrical Specifications.

WIRING – LOW VOLTAGE

All 230/208V 1 phase and 3 phase equipment have dual primary voltage transformers. All equipment leaves the factory wired on 240V tap. For 208V operation, reconnect from 240V to 208V tap. The acceptable operating voltage range for the 240 and 208V taps are:

TAP	RANGE
240	253 – 216
208	220 – 187

NOTE: *The voltage should be measured at the field power connection point in the unit and while the unit is operating at full load (maximum amperage operating condition).*

For wiring size and connections, refer to wiring manual 2100-582.

THESE UNITS REQUIRE R-410A REFRIGERANT AND POLYOL ESTER OIL.

GENERAL

1. Use separate service equipment to avoid cross contamination of oil and refrigerants.
2. Use recovery equipment rated for R-410A refrigerant.
3. Use manifold gauges rated for R-410A (800 psi/250 psi low).
4. R-410A is a binary blend of HFC-32 and HFC-125.
5. R-410A is nearly azeotropic—similar to R-22 and R-12. Although nearly azeotropic, charge with liquid refrigerant.
6. R-410A operates at 40-70% higher pressure than R-22 and systems designed for R-22 cannot withstand this higher pressure.
7. R-410A has an ozone depletion potential of zero, but must be reclaimed due to its global warming potential.
8. R-410A compressors use Polyol Ester oil.
9. Polyol Ester oil is hygroscopic; it will rapidly absorb moisture and strongly hold this moisture in the oil.
10. A liquid line dryer must be used—even a deep vacuum will not separate moisture from the oil.
11. Limit atmospheric exposure to 15 minutes.
12. If compressor removal is necessary, always plug compressor immediately after removal. Purge with small amount of nitrogen when inserting plugs.

TOPPING OFF SYSTEM CHARGE

If a leak has occurred in the system, Bard Manufacturing recommends reclaiming, evacuating (see criteria above) and charging to the nameplate charge. If done correctly, topping off the system charge can be done without problems.

With R-410A, there are no significant changes in the refrigerant composition during multiple leaks and recharges. R-410A refrigerant is close to being an azeotropic blend (it behaves like a pure compound or single component refrigerant). The remaining refrigerant charge, in the system, may be used after leaks have occurred and then “top-off” the charge by utilizing the pressure charts on the inner control panel cover as a guideline.

REMEMBER: When adding R-410A refrigerant, it must come out of the charging cylinder/tank as a liquid to avoid any fractionation, and to ensure optimal system performance. Refer to instructions for the cylinder that is being utilized for proper method of liquid extraction.



SAFETY PRACTICES

1. Never mix R-410A with other refrigerants.
2. Use gloves and safety glasses. Polyol Ester oils can be irritating to the skin, and liquid refrigerant will freeze the skin.
3. Never use air and R-410A to leak check; the mixture may become flammable.
4. Do not inhale R-410A—the vapor attacks the nervous system, creating dizziness, loss of coordination and slurred speech. Cardiac irregularities, unconsciousness and ultimate death can result from breathing this concentration.
5. Do not burn R-410A. This decomposition produces hazardous vapors. Evacuate the area if exposed.
6. Use only cylinders rated DOT4BA/4BW 400.
7. Never fill cylinders over 80% of total capacity.
8. Store cylinders in a cool area, out of direct sunlight.
9. Never heat cylinders above 125°F.
10. Never trap liquid R-410A in manifold sets, gauge lines or cylinders. R-410A expands significantly at warmer temperatures. Once a cylinder or line is full of liquid, any further rise in temperature will cause it to burst.

IMPORTANT INSTALLER NOTE

For improved start up performance wash the indoor coil with a dish washing detergent.

HIGH PRESSURE SWITCH

All W**A/W**L wall mounted air conditioner series models are supplied with a remote reset for the high and low pressure switch. If tripped, this pressure switch may be reset by turning the thermostat off then back on again.

THREE PHASE SCROLL COMPRESSOR START UP INFORMATION

Scroll compressors, like several other types of compressors, will only compress in one rotational direction. Direction of rotation is not an issue with single phase compressors since they will always start and run in the proper direction.

However, three phase compressors will rotate in either direction depending upon phasing of the power. Since there is a 50-50 chance of connecting power in such a way as to cause rotation in the reverse direction, verification of proper rotation must be made. Verification of proper rotation direction is made by observing that suction pressure drops and discharge pressure rises when the compressor is energized. Reverse rotation also results in an elevated sound level over that with correct rotation, as well as substantially reduced current draw compared to tabulated values.

Verification of **proper rotation** must be made at the time the equipment is put into service. If improper rotation is corrected at this time, there will be no negative impact on the durability of the compressor. However, reverse operation for over 1 hour may have a negative impact on the bearing due to oil pump out.

NOTE: *If compressor is allowed to run in reverse rotation for an extended period of time, the compressor's internal protector will trip.*

All three phase compressors are wired identically internally. As a result, once the correct phasing is determined for a specific system or installation, connecting properly phased power leads to the same Fusite terminal should maintain proper rotation direction.

The direction of rotation of the compressor may be changed by reversing any two line connections to the unit.

PHASE MONITOR

All units with three phase scroll compressors are equipped with a three phase line monitor to prevent compressor damage due to phase reversal.

The phase monitor in this unit is equipped with two LEDs. If the Y signal is present at the phase monitor and phases are correct the green LED will light.

If phases are reversed, the red fault LED will be lit and compressor operation is inhibited.

If a fault condition occurs, reverse two of the supply leads to the unit. **Do not reverse any of the unit factory wires as damage may occur.**

CONDENSER FAN OPERATION

NOTE: *Certain models may be equipped with a low ambient control (LAC), and if so equipped, the condenser fan motor will have delayed start until system refrigerant operating pressure builds up. After starting, the fan motor may or may not cycle depending upon ambient conditions. This is normal operation.*

Applies to W42, W48, W60 and W70 models only. The condenser fan motor on 230/208 volt one and three phase 60 HZ units is a two-speed motor that comes factory wired on high speed for peak performance. If ambient conditions permit, it can be reconnected to low speed (red wire) for lower sound level (see wiring diagram).

50 HZ models must have fan wired on low speed. These models are factory wired on low speed.

SERVICE HINTS

1. Caution owner/operator to maintain clean air filters at all times and also not to needlessly close off supply and return air registers. This reduces airflow through the system, which shortens equipment service life as well as increasing operating costs.
2. Check all power fuses or circuit breakers to be sure they are the correct rating.
3. Periodic cleaning of the outdoor coil to permit full and unrestricted airflow circulation is essential.

SEQUENCE OF OPERATION

COOLING – Circuit R-Y makes at thermostat pulling in compressor contactor, starting the compressor and outdoor motor. (See **NOTE** under **Condenser Fan Operation** if equipped with low ambient control.) The G (indoor motor) circuit is automatically completed by the thermostat on any call for cooling operation or can be energized by manual fan switch on subbase for constant air circulation. On a call for heating, circuit R-W1 make at the thermostat pulling in heat contactor for the strip heat and blower operation. On a call for second stage heat, R-W2 makes bringing on second heat contactor, if so equipped.

COMPRESSOR CONTROL MODULE

The compressor control module is standard on all models covered by this manual. The compressor control module is an anti-short cycle/lockout timer with high and low pressure switch monitoring and alarm relay output.

Adjustable Delay-on-Make And Delay-on-Break Timer

On initial power up or anytime power is interrupted to the unit, the *delay-on-make* period begins, which will be 2 minutes plus 10% of the *delay-on-break* setting. When the delay-on-make is complete and the high pressure switch and low pressure switch are closed, the compressor contactor is energized. Upon shutdown, the delay-on-break timer starts and prevents restart until the delay-on-break and delay-on-make periods have expired.

During routine operation of the unit with no power interruptions, the compressor will operate on demand with no delay.

High Pressure Switch and Lockout Sequence

If the high pressure switch opens, the compressor contactor will de-energize immediately. The lockout timer will go into a *soft lockout* and stay in soft lockout until the high pressure switch closes and the delay-on-break time has expired. If the high pressure switch opens again in this same operating cycle, the unit will go into *manual lockout* condition and the alarm relay circuit will energize. Recycling the wall thermostat resets the manual lockout.

Low Pressure Switch, Bypass and Lockout Sequence

If the low pressure switch opens for more than 120 seconds, the compressor contactor will de-energize and go into a soft lockout. Regardless the state of the low pressure switch, the contactor will re-energize after the delay-on-make time delay has expired. If the low pressure switch remains open, or opens again for longer than 120 seconds, the unit will go into manual lockout condition and the alarm relay circuit will energize. Recycling the wall thermostat resets the manual lockout.

Alarm Relay Output

Alarm terminal is output connection for applications where alarm relay is employed. This terminal is powered whenever the compressor is locked out due to HPC or LPC sequences as described.

NOTE: *Both high and low pressure switch controls are inherently automatic reset devices. The high pressure switch and low pressure switch cut out and cut in settings are fixed by specific air conditioner unit model. The lockout features,*

both soft and manual, are a function of the compressor control module.

ADJUSTMENTS

Adjustable Delay-on-Make and Delay-on-Break Timer

The potentiometer is used to select delay-on-break time from 30 seconds to 5 minutes. Delay-on-make (DOM) timing on power-up and after power interruptions is equal to 2 minutes plus 10% of delay-on-break (DOB) setting:

0.5 minute (30 seconds)	DOB = 123 second	DOM
1.0 minute (60 seconds)	DOB = 126 second	DOM
2.0 minute (120 seconds)	DOB = 132 second	DOM
3.0 minute (180 seconds)	DOB = 138 second	DOM
4.0 minute (240 seconds)	DOB = 144 second	DOM
5.0 minute (300 seconds)	DOB = 150 second	DOM

During routine operation of the unit with no power interruptions, the compressor will operate on demand with no delay.

Typical Settings for Dual Unit Installation:

Unit 1: DOB set at 2 minutes and DOM is 132 seconds

Unit 2: DOB set at 4 minutes and DOM is 144 seconds

PRESSURE SERVICE PORTS

High and low pressure service ports are installed on all units so that the system operating pressures can be observed. A pressure table can be found later in the manual covering all models. It is imperative to match the correct pressure table to the unit by model number. See Table 2.

This unit employs high-flow Coremax valves instead of the typical Shrader type valves.

WARNING! Do NOT use a Schrader valve core removal tool with these valves. Use of such a tool could result in eye injuries or refrigerant burns!

To change a Coremax valve without first removing the refrigerant, a special tool is required which can be obtained at www.fastestinc.com/en/SCCA07H. See the replacement parts manual for replacement core part numbers.

SERVICE

FAN BLADE SETTING DIMENSIONS

Shown in Figure 8 is the correct fan blade setting for proper air delivery across the outdoor coil. Refer to Table 1 for unit specific dimension.

Any service work requiring removal or adjustment in the fan and/or motor area will require that the dimensions below be checked and blade adjusted in or out on the motor shaft accordingly.

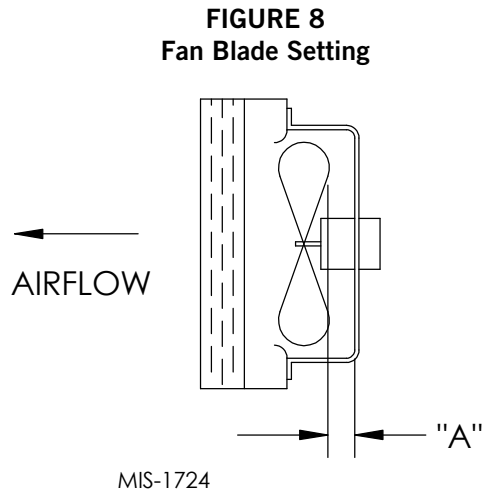

TABLE 1
Fan Blade Dimension

Model	Dimension A
W17A2 / W17L2 W18A2 / W18L2 W24A2 / W24L2	1.00"
W30A2 / W30L2 W36A2 / W36L2	1.25"
W42A2 / W42L2 W48A2 / W48L2 W60A2 / W60L2 W70A2 / W70L2	1.75"

R-410A REFRIGERANT CHARGE

This unit was charged at the factory with the quantity of refrigerant listed on the serial plate. AHRI capacity and efficiency ratings were determined by testing with this refrigerant charge quantity.

The following pressure table shows nominal pressures for the units. Since many installation specific situations can affect the pressure readings, this information should only be used by certified technicians as a guide for evaluating proper system performance. They shall not be used to adjust charge. If charge is in doubt, reclaim, evacuate and recharge the unit to the serial plate charge.

REMOVAL OF FAN SHROUD

1. Disconnect all power to the unit.
2. Remove the screws holding both grilles, one on each side of unit, and remove grilles.
3. Remove nine (9) screws holding fan shroud to condenser and bottom.
4. Unwire condenser fan motor.
5. Slide complete motor, fan blade, and shroud assembly out the left side of the unit.
6. Service motor/fan as needed.
7. Reverse steps to reinstall.

TABLE 2
Cooling Pressure

Air Temperature Entering Outdoor Coil °F

Model	Return Air Temp (DB/WB)	Pressure	75	80	85	90	95	100	105	110	115	120
W17A/L	75/62	Low Side High Side	124 321	126 340	128 362	130 384	132 409	133 434	135 461	137 490	138 521	140 553
	80/67	Low Side High Side	133 329	135 349	137 371	139 394	141 419	142 445	144 473	146 503	148 534	150 567
	85/72	Low Side High Side	138 341	140 361	142 384	144 408	146 434	147 461	149 490	151 521	153 553	155 587
W18A/L	75/62	Low Side High Side	127 318	129 339	131 362	133 385	135 409	137 434	138 459	140 486	143 513	145 541
	80/67	Low Side High Side	136 326	138 348	140 371	142 395	144 419	146 445	148 471	150 498	153 526	155 555
	85/72	Low Side High Side	141 337	143 360	145 384	147 409	149 434	151 461	153 487	155 515	158 544	160 574
W24A/L	75/62	Low Side High Side	119 340	121 361	122 383	124 407	127 432	129 459	131 488	133 518	135 550	137 583
	80/67	Low Side High Side	127 349	129 370	131 393	133 417	136 443	138 471	140 500	142 531	144 564	146 598
	85/72	Low Side High Side	131 361	134 383	136 407	138 432	141 459	143 487	145 518	147 550	149 584	151 619
W30A/L	75/62	Low Side High Side	122 335	124 358	127 381	129 406	131 431	133 456	135 483	137 509	137 536	139 565
	80/67	Low Side High Side	130 344	133 367	136 391	138 416	140 442	142 468	144 495	146 522	147 550	149 579
	85/72	Low Side High Side	135 356	138 380	141 405	143 431	145 457	147 484	149 512	151 540	152 569	154 599
W36A/L	75/62	Low Side High Side	120 339	122 366	124 392	126 418	129 446	130 473	132 501	134 529	135 558	136 586
	80/67	Low Side High Side	128 348	130 375	133 402	135 429	138 457	139 485	141 514	143 543	144 572	145 601
	85/72	Low Side High Side	132 360	135 388	138 416	140 444	143 473	144 502	146 532	148 562	149 592	150 622
W42A/L	75/62	Low Side High Side	123 320	124 342	126 367	128 391	130 416	132 443	134 469	136 496	137 526	139 554
	80/67	Low Side High Side	132 328	133 351	135 376	137 401	139 427	141 454	143 481	145 509	147 539	149 568
	85/72	Low Side High Side	137 339	138 363	140 389	142 415	144 442	146 470	148 498	150 527	152 558	154 588
W48A/L	75/62	Low Side High Side	117 355	119 378	121 403	123 427	125 454	127 482	129 510	131 539	133 570	135 603
	80/67	Low Side High Side	125 364	127 388	129 413	132 438	134 466	136 494	138 523	140 553	142 585	144 618
	85/72	Low Side High Side	129 377	131 402	134 427	137 453	139 482	141 511	143 541	145 572	147 605	149 640
W60A/L	75/62	Low Side High Side	122 346	124 371	126 396	128 421	130 447	131 473	133 499	135 526	137 553	138 580
	80/67	Low Side High Side	131 355	133 380	135 406	137 432	139 458	140 485	142 512	144 539	146 567	148 595
	85/72	Low Side High Side	136 367	138 393	140 420	142 447	144 474	145 502	147 530	149 558	151 587	153 616
W70A/L	75/62	Low Side High Side	118 349	121 371	122 395	123 419	125 444	127 470	129 497	131 525	132 553	134 583
	80/67	Low Side High Side	126 358	129 381	131 405	132 430	134 455	136 482	138 510	140 538	141 567	143 598
	85/72	Low Side High Side	130 371	134 394	136 419	137 445	139 471	141 499	143 528	145 557	146 587	148 619

Low side pressure ± 4 PSIG
High side pressure ± 10 PSIG

Tables are based upon rated CFM (airflow) across the evaporator coil. If there is any doubt as to correct operating charge being in the system, the charge should be removed, system evacuated and recharged to serial plate charge weight.

NOTE: Pressure table based on high speed condenser fan operation. If condensing pressures appear elevated check condenser fan wiring. See "Condenser Fan Operation".

TABLE 5
Recommended Airflow

Model	Nominal Rated CFM *	Nominal Rated ESP *	Recommended Airflow Range	Factory Speed Connection
W17A, W17L	600	.40	550 - 725	Low
W18A, W18L	550	.45	550 - 725	Low
W24A, W24L	800	.30	700 - 950	Single
W30A, W30L	1000	.30	850 - 1300	High
W36A, W36L	1100	.20	930 - 1350	High
W42A, W42L	1400	.45	1600 - 1150	High
W48A, W48L	1550	.30	1750 - 1285	High
W60A, W60L	1700	.40	1950 - 1375	High
W70A, W70L	1700	.20	1950 - 1375	High

* Rated CFM and ESP on factory speed connection.

TABLE 6
Indoor Blower Performance

Speed	W17/18				W24		W30				W36				W42/48				W60				W70			
	High		Low		Single		High		Low		High		Low		High		Low		High		Low		High		Low	
ESP (Inch H2O)	Dry Coil	Wet Coil	Dry Coil	Wet Coil	Dry Coil	Wet Coil	Dry Coil	Wet Coil	Dry Coil	Wet Coil	Dry Coil	Wet Coil	Dry Coil	Wet Coil	Dry Coil	Wet Coil	Dry Coil	Wet Coil	Dry Coil	Wet Coil	Dry Coil	Wet Coil	Dry Coil	Wet Coil	Dry Coil	Wet Coil
0.0	1045	1025	760	745	990	970	1370	1285	910	885	1415	1275	955	925	1850	1800	1605	1555	2080	2015	1505	1460	2050	1845	1490	1400
0.1	1010	970	730	715	945	925	1305	1225	885	860	1350	1215	945	915	1775	1725	1545	1500	2020	1960	1450	1405	1970	1770	1425	1340
0.2	940	905	700	685	890	870	1225	1135	850	815	1265	1125	925	900	1685	1640	1460	1415	1925	1865	1395	1355	1905	1700	1375	1295
0.3	860	830	670	655	820	800	1115	1020	790	755	1190	1060	875	850	1590	1550	1390	1345	1870	1815	1340	1300	1830	1645	1225	1150
0.4	780	750	610	595	735	720	1005	910	695	660	1085	975	780	755	1495	1460	1310	1270	1755	1705	1225	1185	1725	1550	1140	1070
0.5	665	640	485	455	605	590	865	775	590	560	970	865	640	615	1400	1365	1225	1185	1660	1610	1125	1085	1500	1350	1050	985

TABLE 7
Maximum ESP of Operation
Electric Heat Only

Model	W17A/L, W18A/L, W24A/L	W30A/L, W36A/L				W42A/L, W48A/L		W60A/L, W70A/L	
Outlet	FRONT	FRONT		TOP		FRONT		FRONT	
Speed	Single	High	Low	High	Low	High	Low	High	Low
-A0Z	.50	.50	.50	.50	.50	.50	.50	.50	.50
-A04				.50	.45				
-A05	.50	.50	.50			.50	.50	.50	.50
-A08	.50	.50	.50						
-A10		.50	.45	.50	.35			.50	.50
-A15		.40	.35			.50	.50	.50	.50
-A20						.50	.45	.50	.40
-B0Z	.50	.50	.50	.50	.50	.50	.50	.50	.50
-B06	.50	.50	.40						
-B09		.50	.50	.45	.40	.50	.50	.50	.50
-B15		.45	.30			.50	.50	.50	.50
-B18						.50	.50	.50	.50
-C0Z		.50	.50	.50	.50	.50	.50	.50	.50
-C06		.50	.50						
-C09		.50	.40	.45	.40	.50	.50	.50	.50
-C15		.45	.35			.50	.50	.50	.50

Values shown are for units equipped with standard 1" throwaway filter or 1" washable filter.
Derate ESP by .15 for 2" pleated filters.

TABLE 8
Electric Heat

Models	240V-1		208V-1		240V-3		208V-3		460V-3		
	KW	Amps	BTUH	Amps	BTUH	Amps	BTUH	Amps	BTUH	Amps	BTUH
4	16.7	13650	14.4	10240							
5	20.8	17065	18.1	12800							
6					14.4	20500	12.5	15360	7.2	20500	
8	33.3	27300	28.8	20475							
9					21.7	30600	18.7	23030	10.8	30700	
10	41.6	34130	36.2	25600							
12									14.4	40950	
15	62.5	51250	54.0	38400	36.2	51200	31.2	38400	18.0	51200	
18					43.3	61430	37.5	46100			
20	83.2	68260	72.1	51200							

TABLE 9A
Optional Accessories – Right Hand

		W17/18A2-A	W24A2-A	W24A2-B	W24A2-C	W30A2-A	W30A2-B	W30A2-C	W36A2-A	W36A2-B	W36A2-C	W42A2-A	W42A2-B	W42A2-C	W48A2-A	W48A2-B	W48A2-C	W60A2-A	W60A2-B	W60A2-C	W70A2-A	W70A2-B	W70A2-C
Heater Kits	EHWA02-A05	X	X																				
	EHW02A-A08	X	X																				
	EHWA02A-A10	X	X																				
	EHWA24-A04		X																				
	EHWA24-B06			X																			
	EHWH24B-C06				X																		
	EHWA03-A05					X			X														
	EHWA03-A08					X			X														
	EHWA03-A10					X			X														
	EHWA03-A15					X			X														
	EHWA03-B06						X																
	EHW36A-B06										X												
	EHWA03-B09						X			X													
	EHWA37-B15						X			X													
	EHWC03A-C06							X			X												
	EHWC03A-C09							X			X												
	EHWA03A-C12							X			X												
	EHWA03A-C15							X			X												
	EHWA05-A05											X			X								
	EHWA05-A10											X			X			X			X		
	EHWA05-A15											X			X			X			X		
	EHWA05-A20											X			X			X			X		
	EHWA05-B09												X			X							
	EHWA05-B15												X			X			X				X
	EHW05A-B18																		X				
	EHWA05-B18												X			X							
	EHWA05A-C09													X			X			X			X
	EHWA05A-C15													X			X			X			X
	EHWA60-A05																		X			X	
	EHW60A-B09																		X				
EHW70A-B09																						X	
EHW70A-B18																						X	
Circuit Breaker (WMCB) & Pull Disconnect (WMPD)	WMCB-01B			X																			
	WMCB-02A	X																					
	WMCB-02B						X																
	WMCB-03A		X																				
	WMCB-04B									X													
	WMCB-05A					X			X														
	WMCB-05B											X			X								
	WMCB-06B																		X				
	WMCB-08A											X			X								
	WMCB-09A																	X			X		
	WMPD-01C				X			X			X			X			X			X			X
	WMCB-08B																						X

TABLE 9B
Optional Accessories – Left Hand

		W17/18L2-A	W24L2-A	W24L2-B	W30L2-A	W30L2-B	W30L2-C	W36L2-A	W36L2-B	W36L2-C	W42L2-A	W42L2-B	W42L2-C	W48L2-A	W48L2-B	W48L2-C	W60L2-A	W60L2-B	W60L2-C	W70L2-A	W70L2-B	W70L2-C	
Heater Kits	EHWA02A-A05L	X	X																				
	EHWA02A-A08L	X	X																				
	EHWA02-A10L	X	X																				
	EHWA24-B06L			X																			
	EHWA03-A05L				X			X															
	EHWA03-A08L				X																		
	EHWA03-A10L				X			X															
	EHWA03-A15L				X			X															
	EHWA03-B09L					X			X														
	EHWA37-B15L					X			X														
	EHWC03-C09L						X			X													
	EHWA03-C15L						X			X													
	EHWA05-A05L										X			X			X						
	EHWA05-A10L										X			X			X				X		
	EHWA05-A15L										X			X			X				X		
	EHWA05-B09L											X			X								
	EHWA05-B15L											X			X			X				X	
	EHWA05A-C09L												X			X			X				X
	EHWA05A-C15L												X			X			X				X
	EHWA60-A05L																				X		
EHWA60-B09L																		X					
EHW70A-B09L																					X		
Circuit Breaker (WMCB) & Pull Disconnect (WMPD)	WMCB-01B			X																			
	WMCB-02A	X																					
	WMCB-02B					X																	
	WMCB-03A		X																				
	WMCB-04B								X														
	WMCB-05A				X			X															
	WMCB-05B										X				X								
	WMCB-06B																	X					
	WMCB-08A										X				X								
	WMCB-09A																X			X			
	WMPD-01C						X			X			X				X			X			X
	WMCB-09B																					X	

TABLE 10
Vent and Control Options

Part Number	Description	W17, W18, W24	W30, W36	W42, W48, W60, W70
CMC-14	ODT	X	X	X
CMC-15	Start Kit (230V 1-Phase)	X	X	X
CMC-23	DDC	X	X	
CMC-24	DDC			X
CMC-28	LAC	X	X	X
BFAD-2	Barometric Fresh Air Damper - Standard	X		
BOP-2	Blank Off Plate	X		
MFAD-2	Motorized Fresh Air Damper	X		
CRV-2	Commercial Ventilator - Spring Return	X		
ECONWMS-E2	Economizer - School Version, Enthalpy	X		
ECONWMT-E2	Economizer - Bldg. Equipment, Enthalpy	X		
ECONWMT-T2	Economizer - Bldg. Equipment, DB Temp.	X		
ERVF-A2	Energy Recovery Ventilator - 230 Volt	X		
ERVF-C2	Energy Recovery Ventilator - 460 Volt	X		
BFAD-3	Barometric Fresh Air Damper - Standard		X	
BOP-3	Blank Off Plate		X	
MFAD-3	Motorized Fresh Air Damper		X	
CRVS-3	Commercial Ventilator - Spring Return		X	
CRVP-3	Commercial Ventilator - Power Return		X	
ECONWMS-E3	Economizer - School Version, Enthalpy		X	
ECONWMT-E3	Economizer - Bldg. Equipment, Enthalpy		X	
ECONWMT-T3	Economizer - Bldg. Equipment, DB Temp.		X	
ERVF-A3	Energy Recovery Ventilator - 230 Volt		X	
ERVF-C3	Energy Recovery Ventilator - 460 Volt		X	
BFAD-5	Barometric Fresh Air Damper - Standard			X
BOP-5	Blank Off Plate			X
MFAD-5	Motorized Fresh Air Damper			X
CRVS-5	Commercial Ventilator - Spring Return			X
CRVP-5	Commercial Ventilator - Power Return			X
ECONWMS-E5	Economizer - School Version, Enthalpy			X
ECONWMT-E5	Economizer - Bldg. Equipment, Enthalpy			X
ECONWMT-T5	Economizer - Bldg. Equipment, DB Temp.			X
ERVF-A5	Energy Recovery Ventilator - 230 Volt			X
ERVF-C5	Energy Recovery Ventilator - 460 Volt			X