

INSTALLATION INSTRUCTIONS

WALL MOUNTED PACKAGED AIR CONDITIONER

Models: WA182, WA242

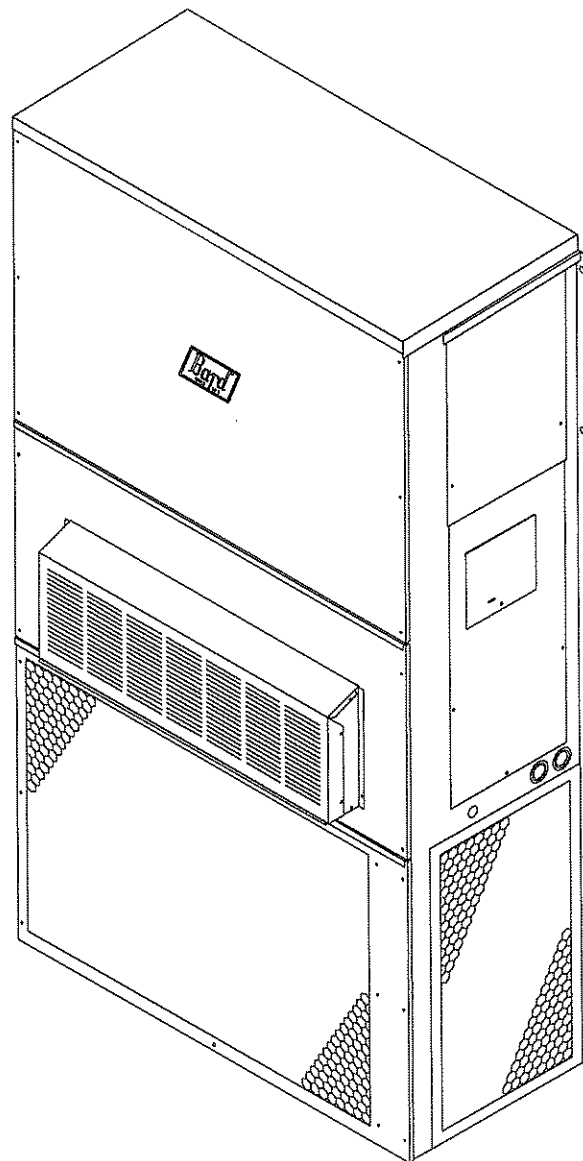

MIS-656



CLIMATE CONTROL SOLUTIONS

Bard Manufacturing Company
Bryan, Ohio 43506
Since 1914...Moving ahead just as planned

Manual No.: 2100-369B
Supersedes: 2100-369A
File: Volume III, Tab 16
Date: 05-13-02

CONTENTS

Getting Other Information and Publications	1	Start Up	12
For more information,		Important Installer Note	12
contact these publishers	1	Crankcase Heaters	12
Wall Mount General Information	2	Service Hints	12
Air Conditioner Wall Mount Model Nomenclature	2	Sequence of Operation	12
Shipping Damage	5	Compressor Control Module	12
General	5	Adjustments	13
Duct Work	5	Pressure Service Ports	13
Filters	5	Troubleshooting	14
Fresh Air Intake	6	Fan Blade Setting Dimensions	14
Condensate Drain	6	Removal of Fan Shroud	14
Installation Instructions	7	Refrigerant Charge	14
Wall Mounting Information	7	Optional Accessories	16
Mounting the Unit	7		
Wiring — Main Power	7		
Wiring — Low Voltage Wiring	7		
Figures		Tables	
Figure 1 Unit Dimensions	3	Table 1 Electric Heat Table	2
Figure 2 Blower Damper Assembly	6	Table 2 Electrical Specifications	4
Figure 3 Mounting Instructions	8	Table 3 Thermostat Wire Size	7
Figure 4 Wall-Mounting Instructions	9	Table 4 Wall Thermostat and	
Figure 5 Wall-Mounting Instructions	9	Subbase Combinations	7
Figure 6 Common Wall-Mounting Installations ...	10	Table 5 Fan Blade Dimensions	14
Figure 7 Low Voltage Wiring	11	Table 6 Suction Line Temperatures	14
Figure 8 Start Up Label	12	Table 7 Indoor Blower Performance	14
Figure 9 Fan Blade Setting	14	Table 8 CFM and ESP	15
		Table 9 Maximum ESP of Operation	
		Electric Heat Only	15
		Table 10 Cooling Pressure	15
		Table 11 Optional Accessories	16

Getting Other Information and Publications

These publications can help you install the air conditioner or heat pump. You can usually find these at your local library or purchase them directly from the publisher. Be sure to consult current edition of each standard.

National Electrical Code ANSI/NFPA 70

Standard for the Installation ANSI/NFPA 90A
of Air Conditioning and
Ventilating Systems

Standard for Warm Air ANSI/NFPA 90B
Heating and Air
Conditioning Systems

Load Calculation for ACCA Manual J
Residential Winter and
Summer Air Conditioning

Duct Design for Residential ACCA Manual D
Winter and Summer Air
Conditioning and Equipment
Selection

For more information, contact these publishers:

ACCA Air Conditioning Contractors of America
1712 New Hampshire Avenue NW
Washington, DC 20009
Telephone: (202) 483-9370
Fax: (202) 234-4721

ANSI American National Standards Institute
11 West Street, 13th Floor
New York, NY 10036
Telephone: (212) 642-4900
Fax: (212) 302-1286

**ASHRAE American Society of Heating Refrigerating,
& Air Conditioning Engineers, Incorporated**
1791 Tullie Circle, N.E.
Atlanta, GA 30329-2305
Telephone: (404) 636-8400
Fax: (404) 321-5478

NFPA National Fire Protection Association
Batterymarch Park
P.O. Box 9101
Quincy, MA 02269-9901
Telephone: (800) 344-3555
Fax: (617) 984-7057

Manufactured under the following U.S. patent numbers:

5,485,878; 5,301,744; 5,002,116; 4,924,934;
4,875,520; 4,825,936

WALL MOUNT GENERAL INFORMATION

Air Conditioner Wall Mount Model Nomenclature

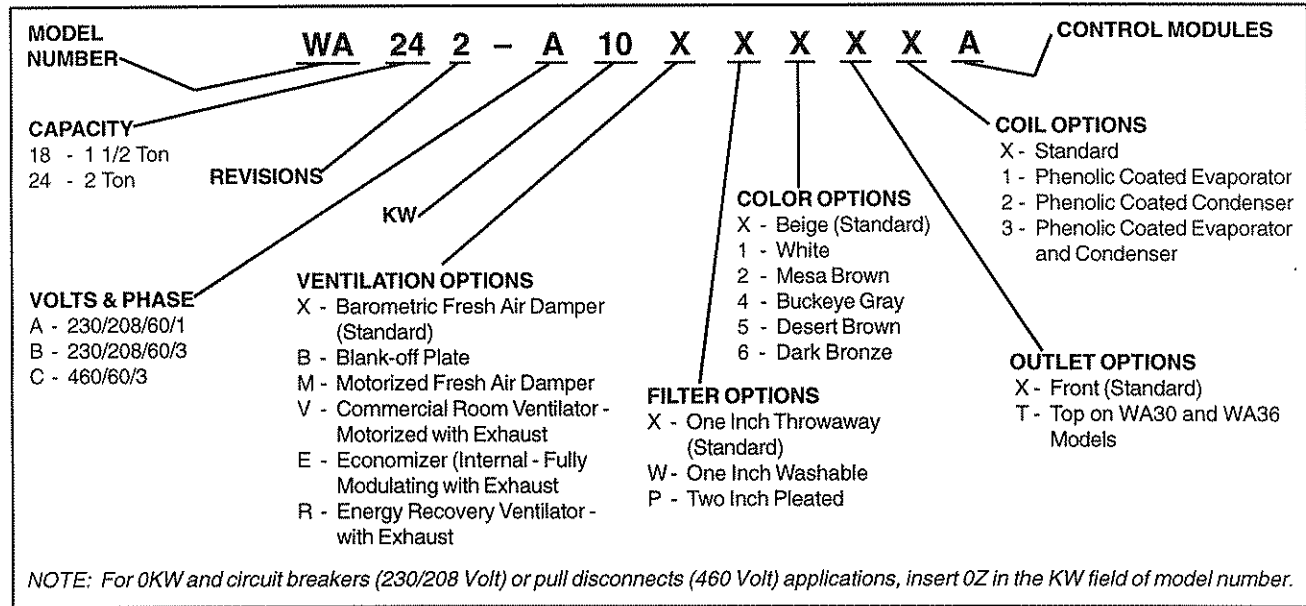
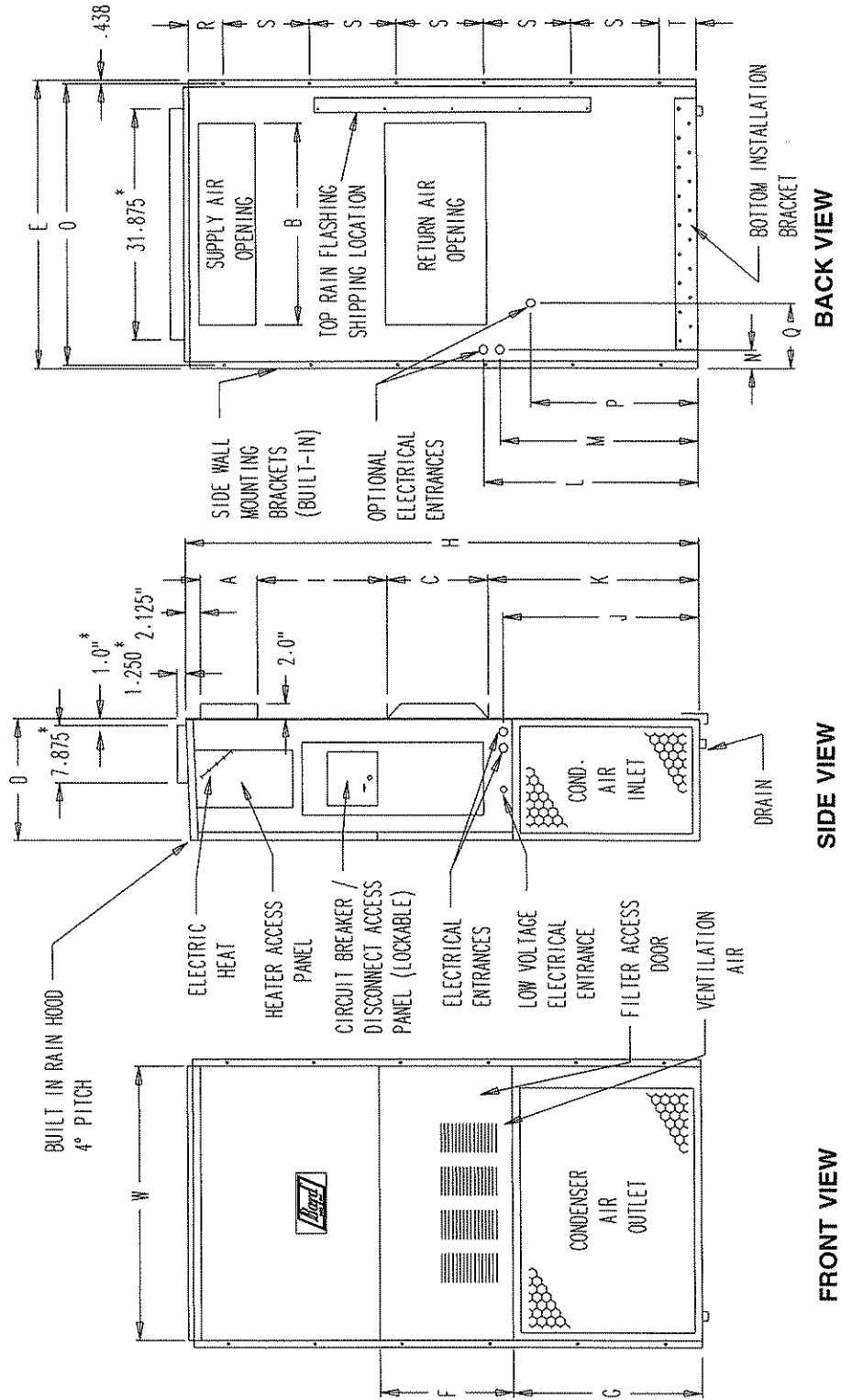

**TABLE 1
ELECTRIC HEAT TABLE**

Models	WA182-A				WA242-A				WA242-B			
	240V-1		208V-1		240V-1		208V-1		240V-3		208V-3	
KW	AMPS	BTUH	AMPS	BTUH	AMPS	BTUH	AMPS	BTUH	AMPS	BTUH	AMPS	BTUH
4					16.7	13,650	14.4	10,240				
5	20.8	17,065	18.1	12,800	20.8	17,065	18.1	12,800				
8	33.3	27,300	28.8	20,475	33.3	27,300	28.8	20,475				
10	41.6	34,130	36.2	25,600	41.6	34,130	36.2	25,600				
6.0									14.4	20,500	12.5	15,360
9.0									21.7	30,600	18.7	23,030

FIGURE 1
UNIT DIMENSIONS

Model	Width (W)	Depth (D)	Height (H)	Supply		Return		E	F	G	I	J	K	L	M	N	O	P	Q	R	S	T
				A	B	C	B															
WA18	33.300	17.125	70.563	7.88	19.88	11.88	19.88	35.00	18.50	25.75	20.56	26.75	28.06	29.25	27.00	2.63	34.13	22.06	10.55	4.19	12.00	5.00
WA24																						



* Optional top outlet (factory installed only) for WA30 and WA36 models only.

**TABLE 2
ELECTRICAL SPECIFICATIONS**

SINGLE CIRCUIT						
Model	Rated Volts & Phase	No. Field Power Circuits	③ Minimum Circuit Ampacity	① Maximum External Fuse or Circuit Breaker	② Field Power Wire Size	② Ground Wire Size
WA182-A00, A0Z A05 A08 A10	230/208-1	1	16	20	12	12
		1	30	30	10	10
		1	45	45	8	10
		1	56	60	6	10
WA242-A00, A0Z A04 A05 A08 A10	230/208-1	1	17	20	12	12
		1	24	25	10	10
		1	30	30	10	10
		1	45	45	8	10
		1	56	60	6	10
WA242-B00, B0Z B06	230/208-3	1	13	15	14	12
		1	22	25	10	10

- ① Maximum size of the time delay fuse or HACR type circuit breaker for protection of field wiring conductors.
- ② Based on 75° copper wire. All wiring must conform to the National Electrical Code and all local codes.
- ③ These "Minimum Circuit Ampacity" values are to be used for sizing the field power conductors. Refer to the National Electric Code (latest revision), Article 310 for power conductor sizing. *CAUTION: When more than one field power conductor circuit is run through one conduit, the conductors must be derated. Pay special attention to note 8 of table 310 regarding Ampacity Adjustment Factors when more than three conductors are in a raceway.*

SHIPPING DAMAGE

Upon receipt of equipment, the carton should be checked for external signs of shipping damage. If damage is found, the receiving party must contact the last carrier immediately, preferably in writing, requesting inspection by the carrier's agent.

GENERAL

The equipment covered in this manual is to be installed by trained, experienced service and installation technicians.

The refrigerant system is completely assembled and charged. All internal wiring is complete.

The unit is designed for use with or without duct work. Flanges are provided for attaching the supply and return ducts.

These instructions explain the recommended method to install the air cooled self-contained unit and the electrical wiring connections to the unit.

These instructions and any instructions packaged with any separate equipment required to make up the entire air conditioning system should be carefully read before beginning the installation. Note particularly "Starting Procedure" and any tags and/or labels attached to the equipment.

While these instructions are intended as a general recommended guide, they do not supersede any national and/or local codes in any way. Authorities having jurisdiction should be consulted before the installation is made. See Page 1 for information on codes and standards.

Size of unit for a proposed installation should be based on heat loss calculation made according to methods of Air Conditioning Contractors of America (ACCA). The air duct should be installed in accordance with the Standards of the National Fire Protection Association for the Installation of Air Conditioning and Ventilating Systems of Other Than Residence Type, NFPA No. 90A, and Residence Type Warm Air Heating and Air Conditioning Systems, NFPA No. 90B. Where local regulations are at a variance with instructions, installer should adhere to local codes.

DUCT WORK

All duct work, supply and return, must be properly sized for the design air flow requirement of the equipment. Air Conditioning Contractors of America (ACCA) is an excellent guide to proper sizing. All duct work or portions thereof not in the conditioned space should be properly insulated in order to both conserve energy and prevent condensation or moisture damage.

Refer to Table 10 for maximum static pressure available for duct design.

Design the duct work according to methods given by the Air Conditioning Contractors of America (ACCA). When duct runs through unheated spaces, it should be insulated with a minimum of 1 inch of insulation. Use insulation with a vapor barrier on the outside of the insulation. Flexible joints should be used to connect the duct work to the equipment in order to keep the noise transmission to a minimum.

A 1/4 inch clearance to combustible material for the first 3 feet of duct attached to the outlet air frame is required. See Wall Mounting Instructions and Figures 3 and 4 for further details.

Ducts through the walls must be insulated and all joints taped or sealed to prevent air or moisture entering the wall cavity.

CAUTION

Some installations may not require any return air duct. A metallic return air grille is required with installations not requiring a return air duct. The spacing between louvers on the grille shall not be larger than 5/8 inches.

Any grille that meets the 5/8 inch louver criteria may be used. It is recommended that Bard Return Air Grille Kit RG-2 through RG-5 or RFG-2 through RFG-5 be installed when no return duct is used. Contact distributor or factory for ordering information. If using a return air filter grille, filters must be of sufficient size to allow a maximum velocity of 400 fpm.

NOTE: If no return air duct is used, applicable installation codes may limit this cabinet to installation only in a single story structure.

FILTERS

A 1 inch throw away filter is supplied with each unit. The filter slides into position making it easy to service. This filter can be serviced from the outside by removing the service door. A 1 inch washable filter and a 2 inch pleated filter are also available as optional accessories. The internal filter brackets are adjustable to accommodate the 2 inch filter by loosening 2 screws in each bracket assembly and sliding the brackets apart to the required width and retightening the 4 screws.

FRESH AIR INTAKE

All units are built with fresh air inlet slots punched in the service panel.

If the unit is equipped with the fresh air damper assembly, the assembly is shipped already attached to the unit. The damper blade is locked in the closed position. To allow the damper to operate, the maximum and minimum blade position stops must be installed. See Figure 2.

All capacity, efficiency and cost of operation information as required for Department of Energy "Energyguide" Fact Sheets is based upon the fresh air blank-off plate in place and is recommended for maximum energy efficiency.

The blank-off plate is available upon request from the factory and is installed in place of the fresh air damper shipped with each unit.

CONDENSATE DRAIN

A plastic drain hose extends from the drain pan at the top of the unit down to the unit base. There are openings in the unit base for the drain hose to pass through. In the event the drain hose is connected to a drain system of some type, it must be an open or vented type system to assure proper drainage.

**FIGURE 2
FRESH AIR DAMPER ASSEMBLY**

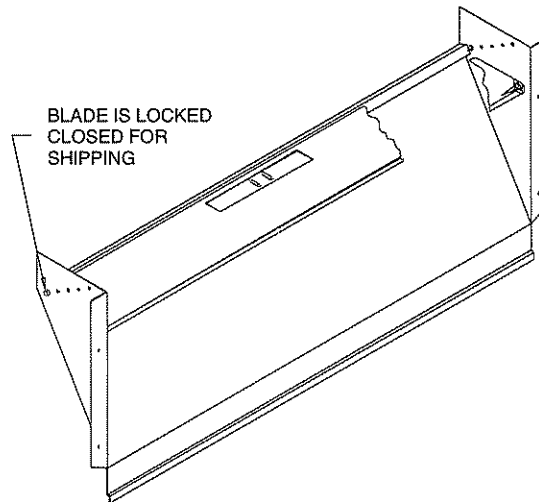

MIS-938

INSTALLATION INSTRUCTIONS

WALL MOUNTING INFORMATION

1. These units are secured by wall mounting brackets which secure the unit to the outside wall surface at both sides. A bottom mounting bracket is provided for ease of installation, but is not required.
2. On wood-frame walls, the wall construction must be strong and rigid enough to carry the weight of the unit without transmitting any unit vibration.
3. Concrete block walls must be thoroughly inspected to insure that they are capable of carrying the weight of the installing unit.

MOUNTING THE UNIT

1. Two holes, for the supply and return air openings, must be cut through the wall as shown in Figure 3.
2. Locate and mark lag bolt locations and bottom mounting bracket location, if desired. See Figure 3.
3. Mount bottom mounting bracket, if used.
4. Hook top rain flashing under back bend of top. Top rain flashing is shipped attached to the back of the unit on the right side.
5. Position unit in opening and secure with 5/16 lag bolts; use 7/8 inch diameter flat washers on the lag bolts.
6. Secure rain flashing to wall and caulk across entire length of top. See Figure 3.
7. For additional mounting rigidity, the return air and supply air frames or collars can be drilled and screwed or welded to the structural wall itself (depending upon wall construction). Be sure to observe required clearance if combustible wall.
8. On side by side installations, maintain a minimum of 20 inches clearance on right side to allow access to heat strips and control panel and to allow proper airflow to the outdoor coil. Additional clearance may be required to meet local or national codes.

TABLE 3
THERMOSTAT WIRE SIZE

Transformer VA	FLA	Wire Gauge	Maximum Distance In Feet
55	2.3	20 gauge	45
		18 gauge	60
		16 gauge	100
		14 gauge	160
		12 gauge	250

WIRING — MAIN POWER

Refer to the unit rating plate for wire sizing information and maximum fuse or "HACR Type" circuit breaker size. Each The disconnect access door on this unit may be locked to prevent unauthorized access to the disconnect. To convert for the locking capability, bend the tab located in the bottom left hand corner of the disconnect opening under the disconnect access panel straight out. This tab will now line up with the slot in the door. When shut, a padlock may be placed through the hole in the tab preventing entry.

WIRING — LOW VOLTAGE WIRING

230/208V, 1 phase and 3 phase equipment dual primary voltage transformers. All equipment leaves the factory wired on 240V tap. For 208V operation, reconnect from 240V to 208V tap. The acceptable operating voltage range for the 240 and 208V taps are:

OPERATING VOLTAGE RANGE

TAP	RANGE
240V	253 - 216
208V	220 - 187

NOTE: The voltage should be measured at the field power connection point in the unit and while the unit is operating at full load (maximum amperage operating condition.)

Five (5) wires should be run from thermostat subbase to the 24V terminal board in the unit. A five conductor, 18 gauge copper, color-coded thermostat cable is recommended. The connection points are shown in Figure 10.

TABLE 4
WALL THERMOSTAT and SUBBASE COMBINATIONS

Thermostat	Subbase	Predominate Features
8403-002 T87F3111	8404-003 Q539A1220	1 stage heat, 1 stage cool System: heat-off-cool Fan: auto-on
8403-041 T8034C	---	1 stage heat, 1 stage cool System: heat-off-cool Fan: auto-on
8403-019 T874C1760	8404-012 Q674A1001	1 stage cool, 2 stage heat System: heat-auto-cool Fan: auto-on
8403-021 T874D1934	8404-012 Q674A1001	2 stage cool, 2 stage heat System: heat-auto-cool Fan: auto-on
8403-049 1F93-380	---	2 stage cool, 2 stage heat Electronic 7 day programming
8403-043 CM-200	---	1 stage heat, 1 stage cool System: heat-off-cool Fan: auto-on

FIGURE 3
MOUNTING INSTRUCTIONS

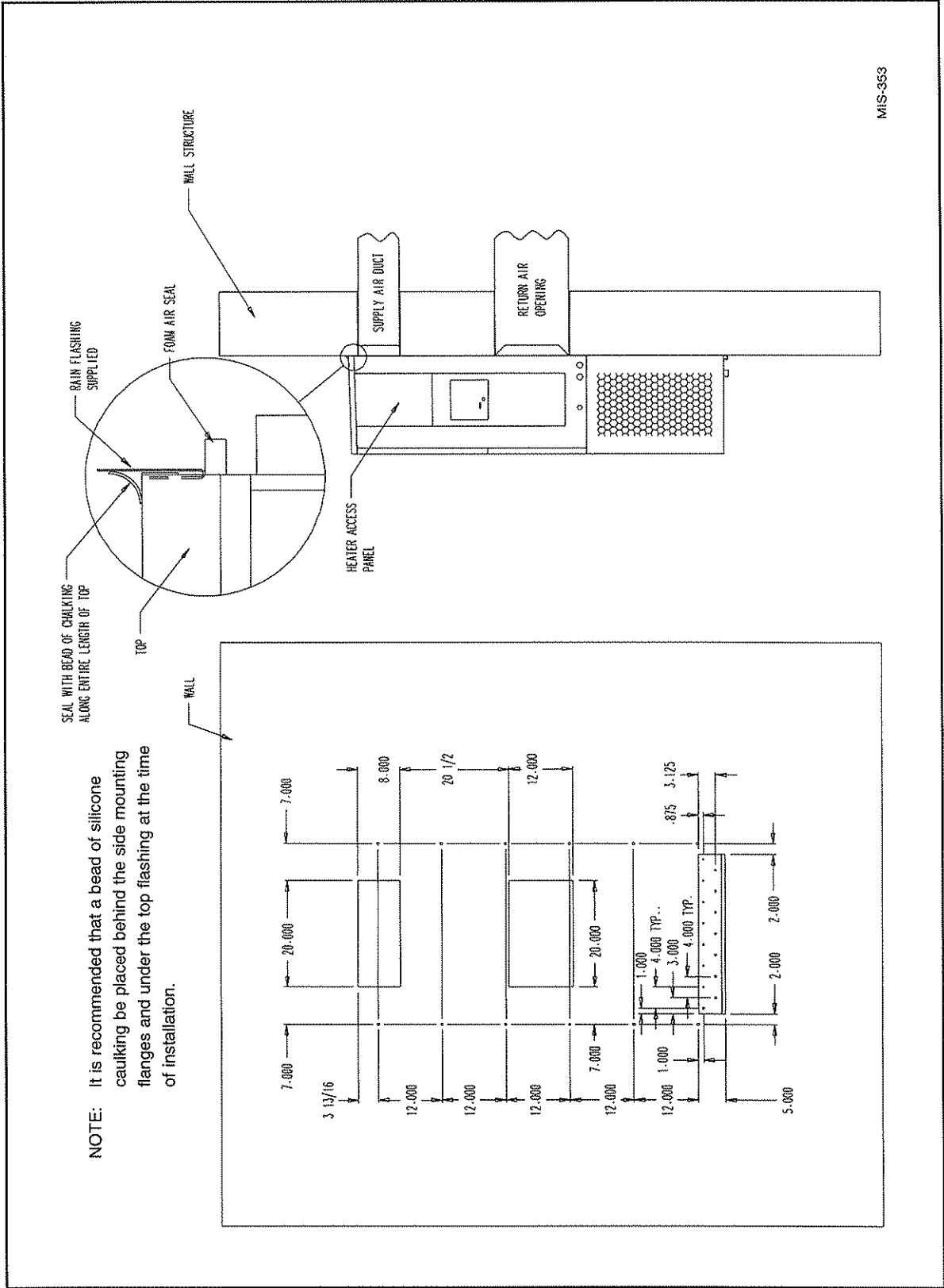

MIS-353

FIGURE 4
WALL-MOUNTING INSTRUCTIONS

SEE FIGURE 3 – MOUNTING INSTRUCTIONS

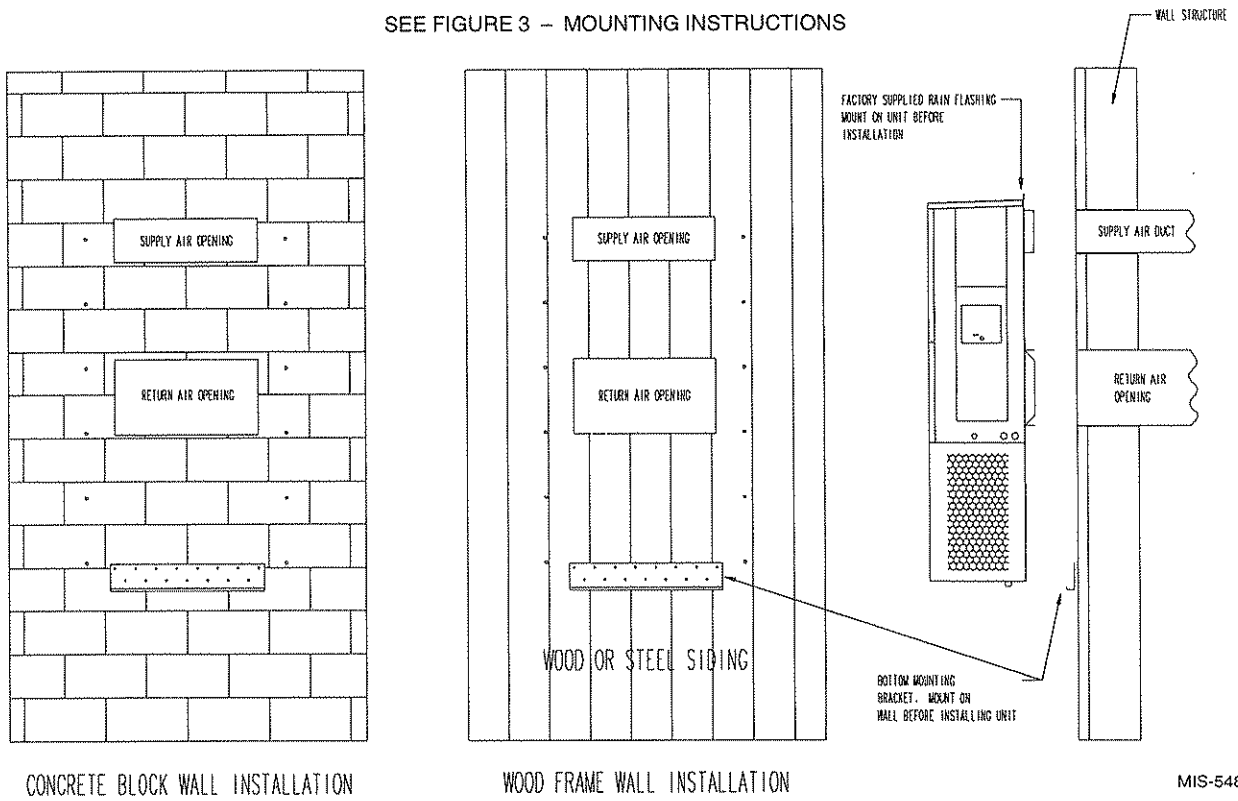

CONCRETE BLOCK WALL INSTALLATION

WOOD FRAME WALL INSTALLATION

MIS-548

FIGURE 5
WALL-MOUNTING INSTRUCTIONS

SEE UNIT DIMENSIONS, FIGURE 1,
FOR ACTUAL DIMENSIONS

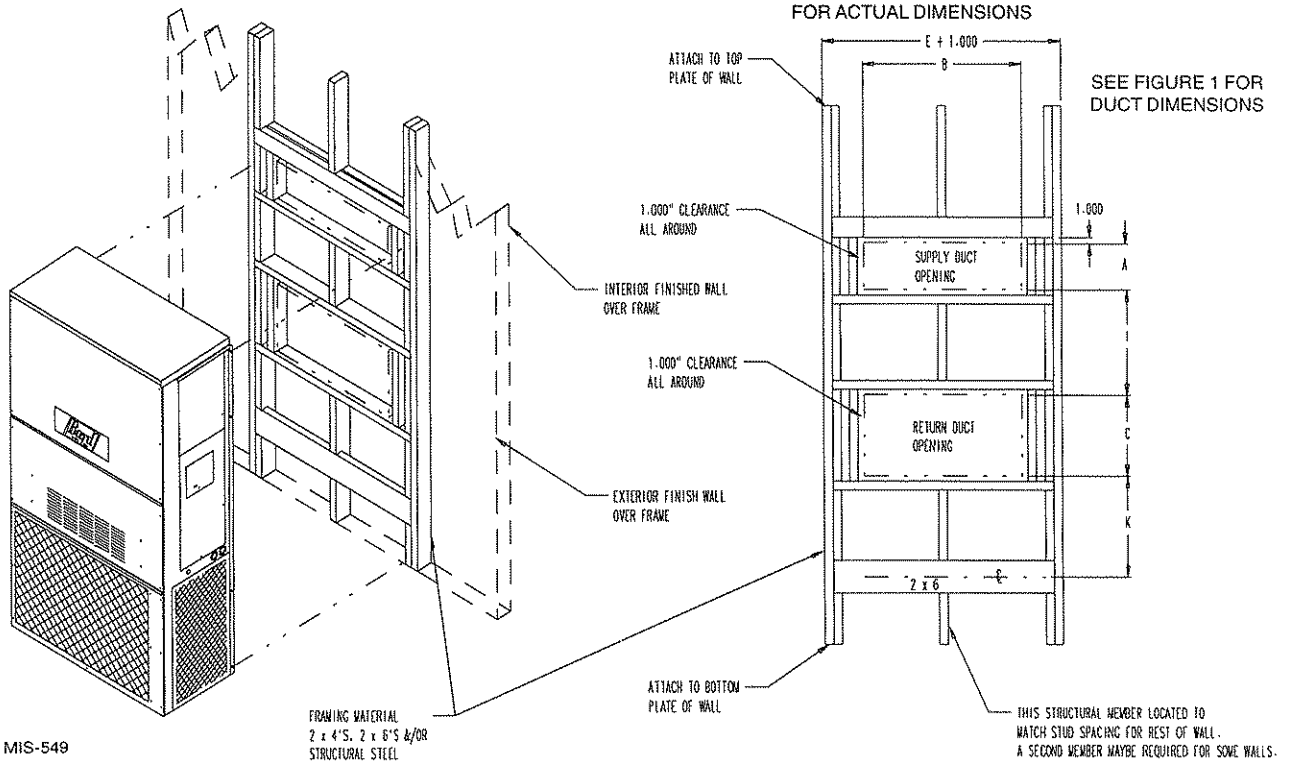

MIS-549

FRAMING MATERIAL
2 x 4'S, 2 x 6'S &/OR
STRUCTURAL STEEL

THIS STRUCTURAL MEMBER LOCATED TO
MATCH STUD SPACING FOR REST OF WALL.
A SECOND MEMBER MAYBE REQUIRED FOR SOME WALLS.

FIGURE 6
COMMON WALL-MOUNTING INSTALLATIONS

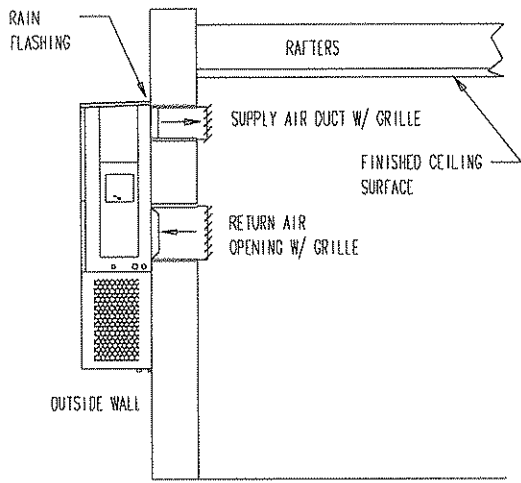

FREE AIR FLOW
NO DUCT

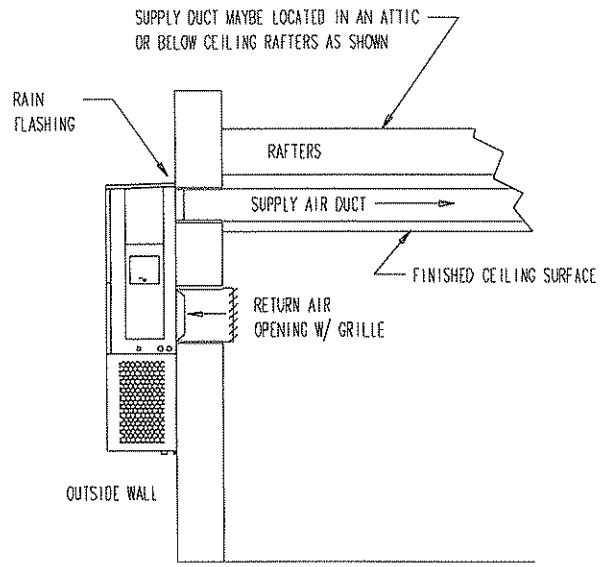

DUCTED SUPPLY
RETURN AT UNIT

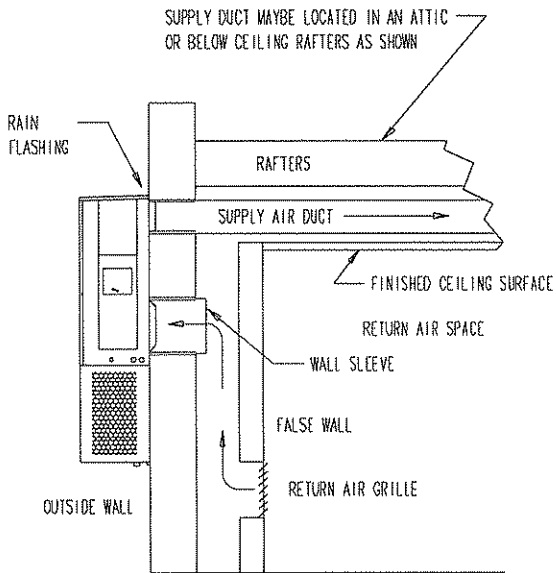

FALSE WALL INSTALLATION

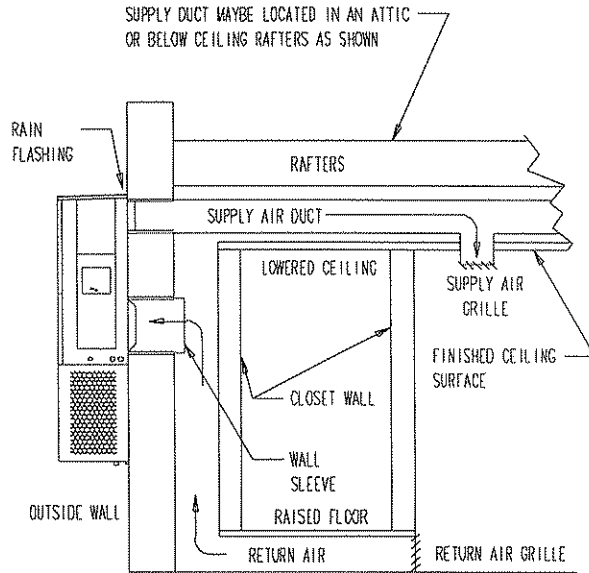

CLOSET INSTALLATION

MIS-550

**FIGURE 7
LOW VOLTAGE WIRING**

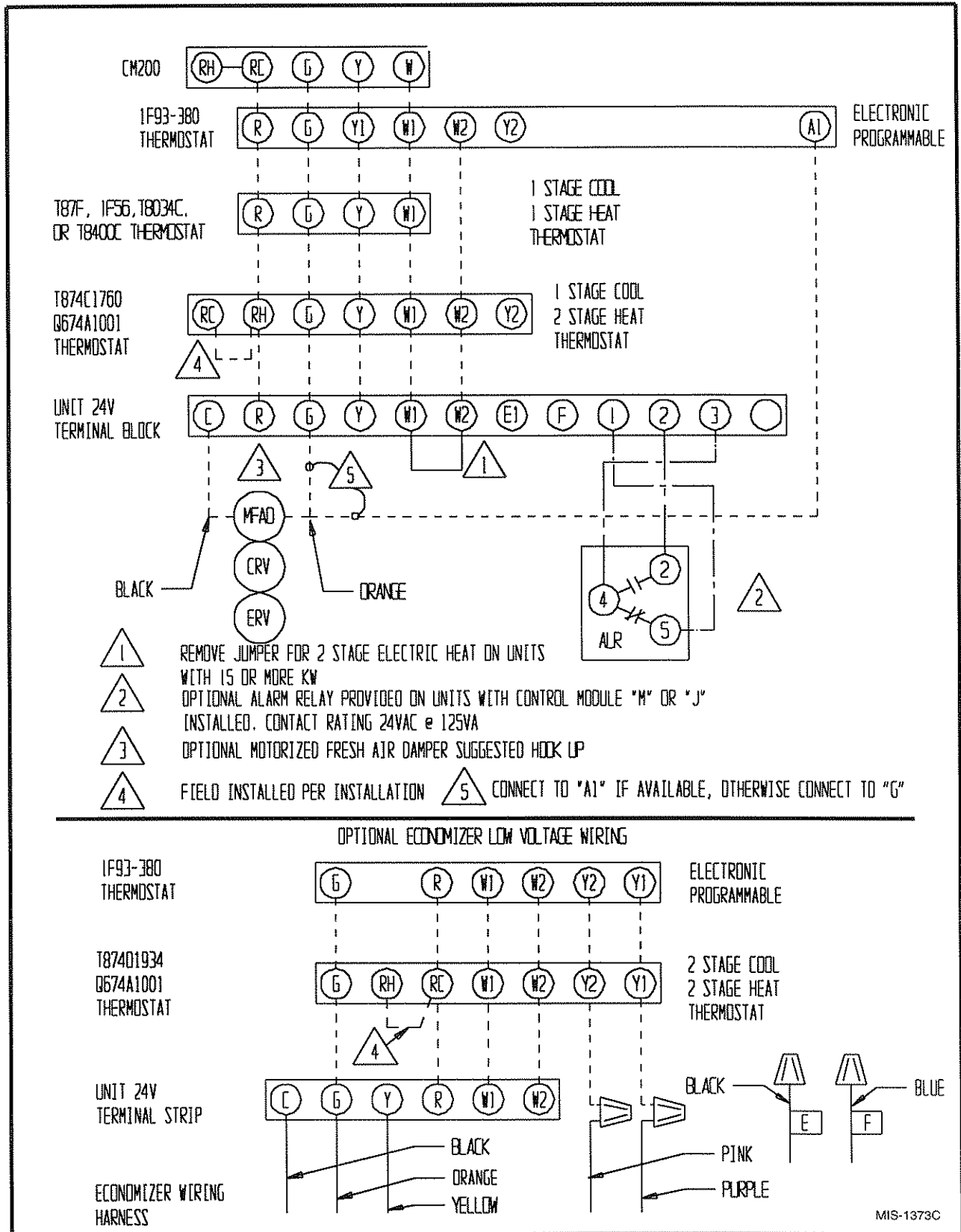

START UP

IMPORTANT INSTALLER NOTE

For improved start-up performance, wash the indoor coil with a dishwasher detergent.

CRANKCASE HEATERS

All units are provided with some form of compressor crankcase heat.

All single and three phase models have an insertion well-type

heater located in the lower section of the compressor housing. This is a self-regulating type heater that draws only enough power to maintain the compressor at a safe temperature.

Some form of crankcase heat is essential to prevent liquid refrigerant from migrating to the compressor, causing oil pump out on compressor start up and possible valve failure due to compressing a liquid.

The decal in Figure 8 is affixed to all outdoor units detailing start up procedure. This is very important. Please read carefully.

SERVICE HINTS

1. Caution homeowner to maintain clean air filters at all times. Also, not to needlessly close off supply and return air registers. This reduces air flow through the system, which shortens equipment service life as well as increasing operating costs.
2. Check all power fuses or circuit breakers to be sure they are the correct rating.
3. Periodic cleaning of the outdoor coil to permit full and unrestricted airflow circulation is essential.

SEQUENCE OF OPERATION

Cooling—Circuit R-Y makes at thermostat pulling in compressor contactor, starting the compressor and outdoor motor. The G (indoor motor) circuit is automatically completed on any call for cooling operation or can be energized by manual fan switch on subbase for constant air circulation. On all 230 volt units there is a one minute off delay on the blower motor. 460 volt models do not have an off delay. On a call for heating, circuit R-W1 make at the thermostat pulling in heat contact for the strip heat and blower operation. On a call for second stage heat, R-W2 makes bringing on second heat contactor, if so equipped.

FIGURE 8
START UP LABEL

IMPORTANT

These procedures must be followed at initial start up and at any time power has been removed for 12 hours or longer.

To prevent compressor damage which may result from the presence of liquid refrigerant in the compressor crankcase:

1. Make certain the room thermostat is in the "off" position (the compressor is not to operate).
2. Apply power by closing the system disconnect switch. This energizes the compressor heater which evaporates the liquid refrigerant in the crankcase.
3. Allow 4 hours or 60 minutes per pound of refrigerant in the system as noted on the unit rating plate, whichever is greater.
4. After properly elapsed time, the thermostat may be set to operate the compressor.
5. Except as required for safety while servicing, **do not open system disconnect switch.**

7961-061

COMPRESSOR CONTROL MODULE

The compressor control module is optional on the models covered by this manual. The compressor control is an anti-short cycle/lockout timer with high and low pressure switch monitoring and alarm relay output.

Adjustable Delay On Make And Break Timer

On initial power up or any time power is interrupted to the unit the *delay on make* period begins which will be 2 minutes plus 10% of the *delay on break* setting. When the delay on make is complete and the high pressure switch (and low pressure switch if employed) is closed, the compressor contactor is energized. Upon shutdown the delay or break timer starts and prevents restart until the delay on break and delay on make periods have expired. During routine operation of the unit with no power interruptions the compressor will operate on demand with no delay.

High Pressure Switch and Lockout Sequence

If the high pressure switch opens, the compressor contactor will de-energize immediately. The lockout timer will go into a *soft lockout* and stay in soft lockout until the high pressure switch closes and the delay on break time has expired. If the high pressure switch opens again in this same operating cycle the unit will go into *manual lockout* condition and the alarm relay circuit will energize. Recycling the wall thermostat resets the manual lockout.

Low Pressure Switch, Bypass, and Lockout Sequence

If the low pressure switch opens for more than 120 seconds, the compressor contactor will de-energize and go into a soft lockout. Regardless the state of the low pressure switch, the contactor will reenergize after the delay on make time delay has expired. If the low pressure switch remains open, or opens again for longer than 120 seconds the unit will go into manual lockout condition and the alarm relay circuit will energize. Recycling the wall thermostat resets the manual lockout.

Alarm Relay Output

Alarm terminal is output connection for applications where alarm relay is employed. This terminal is powered whenever compressor is locked out due to HPC or LPC sequences as described.

NOTE: Both high and low pressure switch controls are inherently automatic reset devices. The high pressure switch and low pressure switch cut out and cut in settings are fixed by specific air conditioner or heat pump unit model. The lockout features, both soft and manual, are a function of the Compressor Control Module.

ADJUSTMENTS

Adjustable Delay on Make and Delay on Break Timer

The potentiometer is used to select Delay on Break time from 30 seconds to 5 minutes. Delay on Make (DOM) timing on power-up and after power interruptions is equal to 2 minutes plus 10% of Delay on Break (DOB) setting:

0.5 minute (30 seconds)	DOB =123 second	DOM
1.0 minute (60 seconds)	DOB =126 second	DOM
2.0 minute (120 seconds)	DOB =132 second	DOM
3.0 minute (180 seconds)	DOB =138 second	DOM
4.0 minute (240 seconds)	DOB =144 second	DOM
5.0 minute (300 seconds)	DOB =150 second	DOM

During routine operation of the unit with now power interruptions the compressor will operate on demand with no delay.

Typical Settings for Dual Unit Installation:

Unit No. 1: DOB set at 2 minutes, and DOM is 132 sec.

Unit No. 2: DOB set at 4 minutes, and DOM is 144 sec.

PRESSURE SERVICE PORTS

High and low pressure service ports are installed on all units so that the system operating pressures can be observed. Pressure tables can be found later in the manual covering all models. It is imperative to match the correct pressure table to the unit by model number.

TROUBLESHOOTING

FAN BLADE SETTING DIMENSIONS

Shown in the drawing below are the correct fan blade setting dimensions for proper air delivery across the outdoor coil.

Any service work requiring removal or adjustment in the fan and/or motor area will require that the dimensions below be checked and blade adjusted in or out on the motor shaft accordingly.

**FIGURE 9
FAN BLADE SETTING**

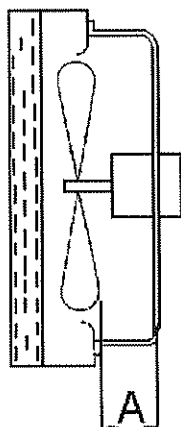

**TABLE 5
FAN BLADE DIMENSION**

Model	Dimension A
WA182 WA242	1.00

REMOVAL OF FAN SHROUD

1. Disconnect all power to unit.
2. Remove the screws holding both grills, one on each side of unit, and remove grills.
3. Remove screws holding fan shroud to condenser and bottom – 9 screws.
4. Unwire condenser fan motor.
5. Slide complete motor, fan blade, and shroud assembly out the left side of the unit.
6. Service motor/fan as needed.
7. Reverse steps to reinstall.

REFRIGERANT CHARGE

The correct system R-22 charge is shown on the unit rating plate. Optimum unit performance will occur with a refrigerant charge resulting in a suction line temperature (6 inches from compressor) as shown in Table 8.

**TABLE 6
SUCTION LINE TEMPERATURES**

Model	Rated Airflow	95 F OD Temperature	82 F OD Temperature
WA182	650	51 - 53	63 - 65
WA242	800	61 - 63	63 - 65

The suction line temperatures in Table 8 are based upon 80°F dry bulb/67°F wet bulb (50 percent R.H.) temperature and rated airflow across the evaporator during cooling cycle.

**TABLE 7
INDOOR BLOWER PERFORMANCE
CFM AT 230 VOLTS**

E.S.P. In H ₂ O	WA182, WA242	
	230V	
	Dry Coil	Wet Coil
.0	1020	975
.1	960	905
.2	865	800
.3	820	735
.4	735	650
.5	615	535

**TABLE 8
CFM and ESP**

Model	① Rated CFM	① Rated ESP	Recommended Airflow Range
WA182	650	.40	575 - 725
WA242	800	.20	700 - 950

① Rated CFM and ESP on high speed tap

**TABLE 9
MAXIMUM ESP OF OPERATION
ELECTRIC HEAT ONLY**

Model	KW	ESP
WA182 WA242	A00	.50
	A05	.50
	A08	.50
WA242	B00	.50
	B06	.50

**TABLE 10
COOLING PRESSURE – OUTDOOR TEMPERATURE °F**

Model	Return Air Temperature	Pressure	75	80	85	90	95	100	105	110	115
WA182	75 deg DB 62 deg WB	Low Side	71	73	75	77	79	81	82	84	85
		High Side	194	208	223	238	253	268	284	299	315
	80 deg DB 67 deg WB	Low Side	76	78	80	83	84	86	88	90	91
		High Side	199	214	229	244	259	275	291	307	323
	85 deg DB 72 deg WB	Low Side	81	84	86	89	91	93	95	96	98
		High Side	206	221	237	253	268	285	301	318	334
WA242	75 deg DB 62 deg WB	Low Side	72	75	78	80	82	84	86	87	89
		High Side	198	214	230	246	261	276	291	305	319
	80 deg DB 67 deg WB	Low Side	74	77	80	82	84	86	88	90	91
		High Side	211	229	246	263	280	295	311	326	341
	85 deg DB 72 deg WB	Low Side	77	80	83	85	87	89	91	93	94
		High Side	227	246	265	283	300	318	334	351	367

Low side pressure ± 2 psig

High side pressure ± 5 psig

Tables are based upon rated CFM (airflow) across the evaporator coil and should be found under section titled "refrigerant charge" elsewhere in manual. If there is any doubt as to correct charge being in the system, the charge should be removed, system evacuated and recharged to serial plate instructions.

**TABLE 11
OPTIONAL ACCESSORIES**

MODEL	DESCRIPTION	WA182-A	WA242-A	WA242-B
EHWA24-A04	Heater Packages		X	
EHWA02-A05	Heater Packages	X	X	
EHWA02A-A08	Heater Packages	X	X	
EHWA02A-A10	Heater Packages	X	X	
EHWA24-B06	Heater Packages			X
BOP-2	Blank Off Plate	X	X	X
BFAD-2	Barometric Fresh Air Damper	X	X	X
MFAD-2	Motorized Fresh Air Damper	X	X	X
CRV-2	Commercial Ventilator with Exhaust	X	X	X
EIFM-2	Economizer with Exhaust	X	X	X
WERV-A2B	Energy Recovery Ventilator	X	X	X
CMA-5	Time Delay Relay (TDR)	X	X	X
CMA-6	Low Ambient Control (LAC)	X	X	X
CMA-8	TDR + HPC	X	X	X
CMA-10A	LPC + HPC + TDR	X	X	X
CMA-13A	LPC + HPC + TDR + LAC	X	X	X
CMC-15	Start Kit	X	X	
WMCB-02A	Circuit Breaker Kit	X	X	
WMCB-01B	Circuit Breaker Kit			X

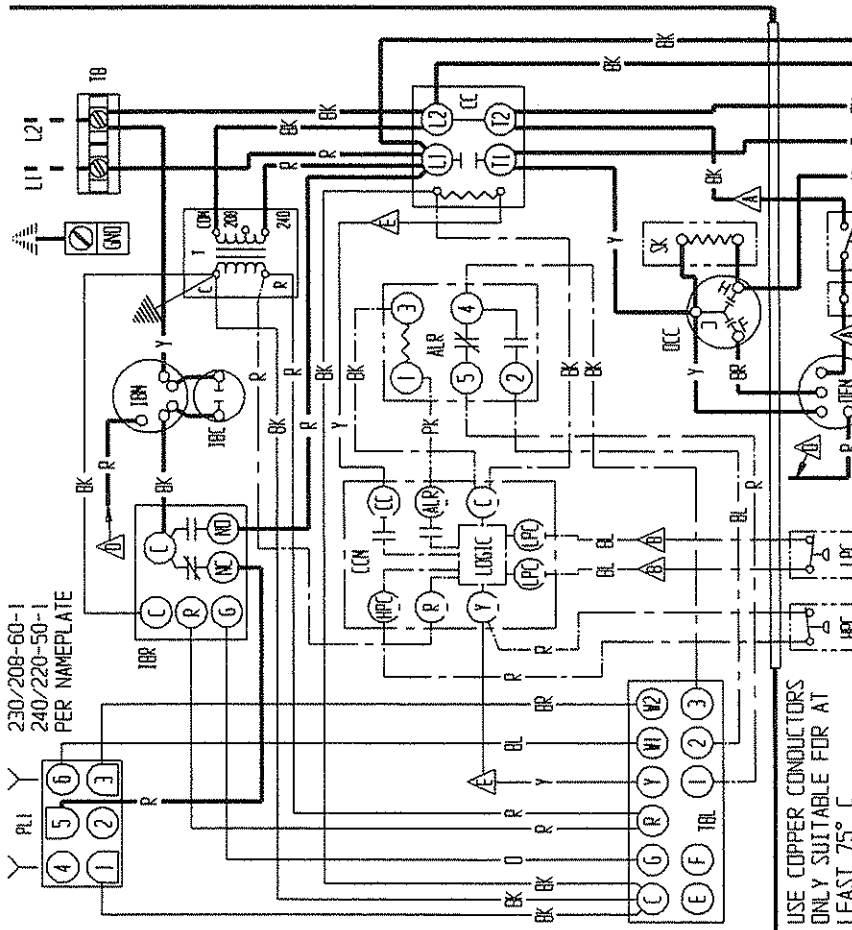
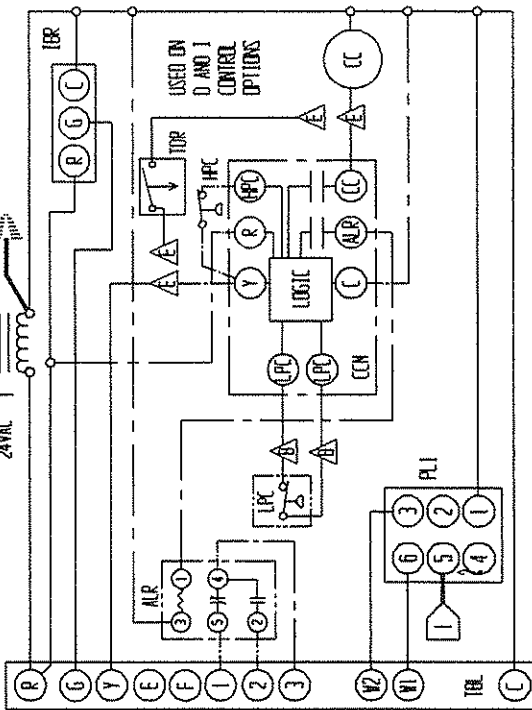
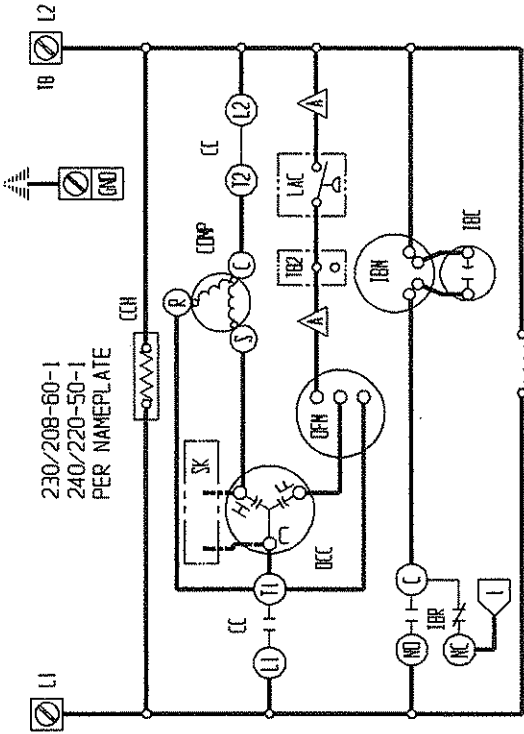

COMPONENT CODE

ALR	ALARM RELAY	IBR	INDOOR BLINDER CAPACITOR
CB1	CIRCUIT BREAKER #1	IBN	INDOOR BLINDER MOTOR
CB2	CIRCUIT BREAKER #2	IBZ	INDOOR BLINDER RELAY
CC	COMPRESSOR CONTACTOR	LAC	LOW AMBIENT CONTROL
CCH	COMPRESSOR HEATER	LPC	LOW PRESSURE CONTROL
CCH	COMPRESSOR CONTROL MOBILE	LS	LIMIT SWITCH
CR	CRANKCASE HEAT RELAY	DFN	OUTDOOR FAN MOTOR
COMP	COMPRESSOR	PLI	PLUG #1
DCC	DUAL CAN CAPACITOR	SK	START KIT
GND	EQUIPMENT GROUND	T	TRANSFORMER
H1	HEAT STRIP #1	IB, IBZ	TERMINAL BLOCK
H2	HEAT STRIP #2	IBL	LOW VOLTAGE TERMINAL BLOCK
H2	HEATER CONTACTOR #1	ICD	THERMAL CUTOFF
H2	HEATER CONTACTOR #2	TDR	TIME DELAY RELAY
HFC	HIGH PRESSURE CONTROL		

△ Labeled wires connect if no options used.

△ Move red wire to 208V tap for 208V operation

△ Red (Low) Black (High) where applicable

BARCO MFG. CO.
4095-130 B

COLOR CODE			
BK	BLACK	Y	YELLOW
BR	BROWN	G	GREEN
R	RED	BL	BLUE
D	ORANGE	W	WHITE
		(S)	GRAY
		(V)	VIOLET
		PK	PINK
		L	LAVENDER

FACTORY STD.	FIELD	OPTIONAL
---	---	---
---	---	---
---	---	---
---	---	---

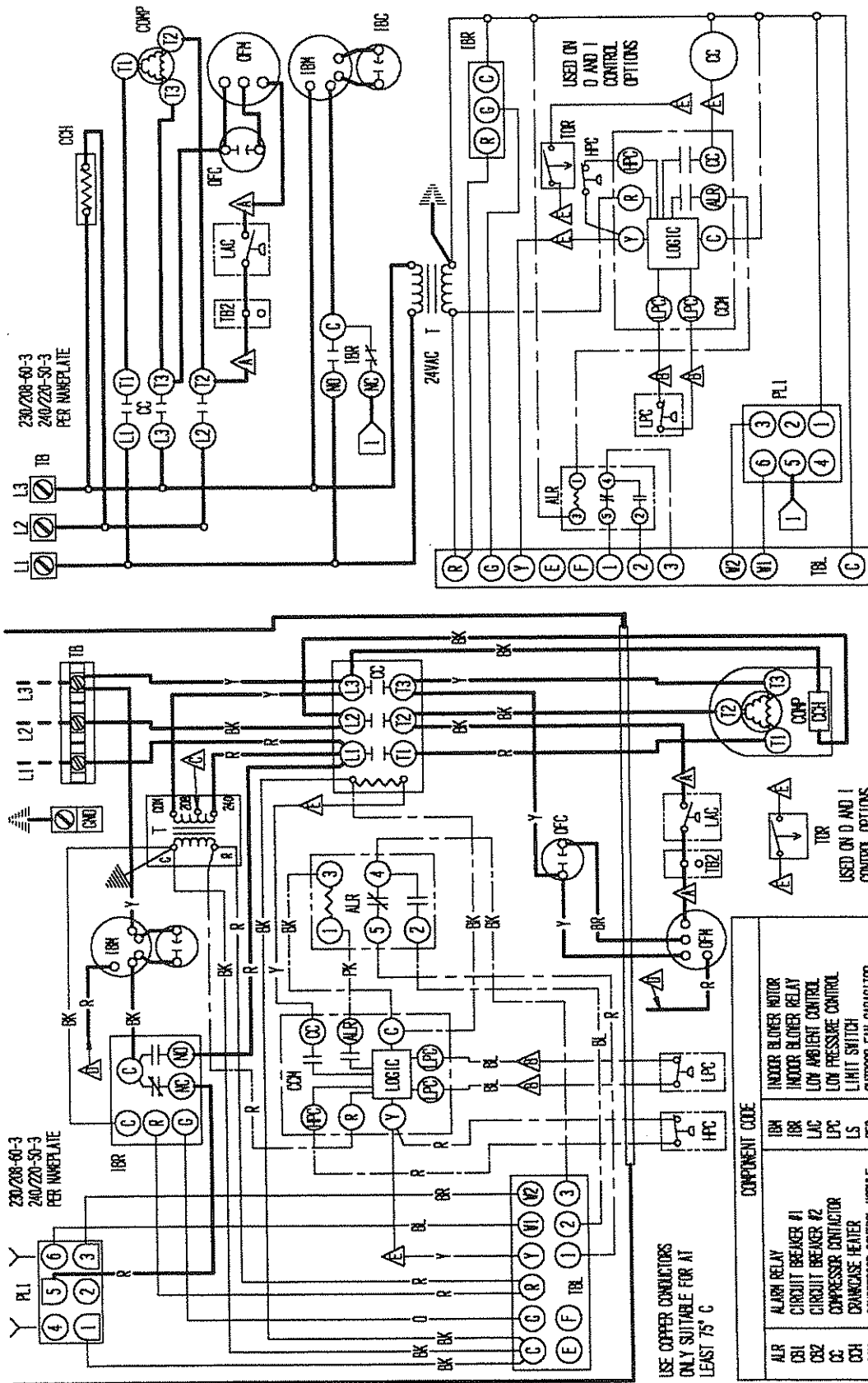

230/208-60-3
240/240-50-3
PER NAMEPLATE

230/208-60-3
240/240-50-3
PER NAMEPLATE

USE COPPER CONDUCTORS
ONLY SUITABLE FOR AT
LEAST 75° C

COMPONENT CODE	
ALR	ALARM RELAY
CB1	INDOOR BLOWER MOTOR
CB2	INDOOR BLOWER RELAY
CC	CIRCUIT BREAKER #1
CC2	CIRCUIT BREAKER #2
CC3	COMPRESSOR CONTACTOR
CC4	COMPRESSOR CONTACTOR #1
CC5	COMPRESSOR CONTACTOR #2
CC6	COMPRESSOR CONTACTOR #3
CC7	COMPRESSOR CONTACTOR #4
CC8	COMPRESSOR CONTACTOR #5
CC9	COMPRESSOR CONTACTOR #6
CC10	COMPRESSOR CONTACTOR #7
CC11	COMPRESSOR CONTACTOR #8
CC12	COMPRESSOR CONTACTOR #9
CC13	COMPRESSOR CONTACTOR #10
CC14	COMPRESSOR CONTACTOR #11
CC15	COMPRESSOR CONTACTOR #12
CC16	COMPRESSOR CONTACTOR #13
CC17	COMPRESSOR CONTACTOR #14
CC18	COMPRESSOR CONTACTOR #15
CC19	COMPRESSOR CONTACTOR #16
CC20	COMPRESSOR CONTACTOR #17
CC21	COMPRESSOR CONTACTOR #18
CC22	COMPRESSOR CONTACTOR #19
CC23	COMPRESSOR CONTACTOR #20
CC24	COMPRESSOR CONTACTOR #21
CC25	COMPRESSOR CONTACTOR #22
CC26	COMPRESSOR CONTACTOR #23
CC27	COMPRESSOR CONTACTOR #24
CC28	COMPRESSOR CONTACTOR #25
CC29	COMPRESSOR CONTACTOR #26
CC30	COMPRESSOR CONTACTOR #27
CC31	COMPRESSOR CONTACTOR #28
CC32	COMPRESSOR CONTACTOR #29
CC33	COMPRESSOR CONTACTOR #30
CC34	COMPRESSOR CONTACTOR #31
CC35	COMPRESSOR CONTACTOR #32
CC36	COMPRESSOR CONTACTOR #33
CC37	COMPRESSOR CONTACTOR #34
CC38	COMPRESSOR CONTACTOR #35
CC39	COMPRESSOR CONTACTOR #36
CC40	COMPRESSOR CONTACTOR #37
CC41	COMPRESSOR CONTACTOR #38
CC42	COMPRESSOR CONTACTOR #39
CC43	COMPRESSOR CONTACTOR #40
CC44	COMPRESSOR CONTACTOR #41
CC45	COMPRESSOR CONTACTOR #42
CC46	COMPRESSOR CONTACTOR #43
CC47	COMPRESSOR CONTACTOR #44
CC48	COMPRESSOR CONTACTOR #45
CC49	COMPRESSOR CONTACTOR #46
CC50	COMPRESSOR CONTACTOR #47
CC51	COMPRESSOR CONTACTOR #48
CC52	COMPRESSOR CONTACTOR #49
CC53	COMPRESSOR CONTACTOR #50
CC54	COMPRESSOR CONTACTOR #51
CC55	COMPRESSOR CONTACTOR #52
CC56	COMPRESSOR CONTACTOR #53
CC57	COMPRESSOR CONTACTOR #54
CC58	COMPRESSOR CONTACTOR #55
CC59	COMPRESSOR CONTACTOR #56
CC60	COMPRESSOR CONTACTOR #57
CC61	COMPRESSOR CONTACTOR #58
CC62	COMPRESSOR CONTACTOR #59
CC63	COMPRESSOR CONTACTOR #60
CC64	COMPRESSOR CONTACTOR #61
CC65	COMPRESSOR CONTACTOR #62
CC66	COMPRESSOR CONTACTOR #63
CC67	COMPRESSOR CONTACTOR #64
CC68	COMPRESSOR CONTACTOR #65
CC69	COMPRESSOR CONTACTOR #66
CC70	COMPRESSOR CONTACTOR #67
CC71	COMPRESSOR CONTACTOR #68
CC72	COMPRESSOR CONTACTOR #69
CC73	COMPRESSOR CONTACTOR #70
CC74	COMPRESSOR CONTACTOR #71
CC75	COMPRESSOR CONTACTOR #72
CC76	COMPRESSOR CONTACTOR #73
CC77	COMPRESSOR CONTACTOR #74
CC78	COMPRESSOR CONTACTOR #75
CC79	COMPRESSOR CONTACTOR #76
CC80	COMPRESSOR CONTACTOR #77
CC81	COMPRESSOR CONTACTOR #78
CC82	COMPRESSOR CONTACTOR #79
CC83	COMPRESSOR CONTACTOR #80
CC84	COMPRESSOR CONTACTOR #81
CC85	COMPRESSOR CONTACTOR #82
CC86	COMPRESSOR CONTACTOR #83
CC87	COMPRESSOR CONTACTOR #84
CC88	COMPRESSOR CONTACTOR #85
CC89	COMPRESSOR CONTACTOR #86
CC90	COMPRESSOR CONTACTOR #87
CC91	COMPRESSOR CONTACTOR #88
CC92	COMPRESSOR CONTACTOR #89
CC93	COMPRESSOR CONTACTOR #90
CC94	COMPRESSOR CONTACTOR #91
CC95	COMPRESSOR CONTACTOR #92
CC96	COMPRESSOR CONTACTOR #93
CC97	COMPRESSOR CONTACTOR #94
CC98	COMPRESSOR CONTACTOR #95
CC99	COMPRESSOR CONTACTOR #96
CC100	COMPRESSOR CONTACTOR #97
CC101	COMPRESSOR CONTACTOR #98
CC102	COMPRESSOR CONTACTOR #99
CC103	COMPRESSOR CONTACTOR #100

▲ Labeled wires connect if no options used. ▲ Move red wire to 208V tap for 208V operation. ▲ Red (low) black (high) where applicable.

Factory Std.	Field	Optional
HIGH VOLTAGE	---	---
LOW VOLTAGE	---	---
ACCESSORY	---	---

COLOR CODE		
BK	BLACK	Y
BR	BROWN	G
R	RED	BL
O	ORANGE	W
Y	YELLOW	W
G	GREEN	Y
(PR)	PURPLE	PK
GY	GRAY	L
(S)	SLATE	
W	WHITE	
PL1	PLUG #1	
3		
2		
1		
6		
5		
4		
1		
2		
3		
4		
5		
6		
7		
8		
9		
10		
11		
12		
13		
14		
15		
16		
17		
18		
19		
20		
21		
22		
23		
24		
25		
26		
27		
28		
29		
30		
31		
32		
33		
34		
35		
36		
37		
38		
39		
40		
41		
42		
43		
44		
45		
46		
47		
48		
49		
50		
51		
52		
53		
54		
55		
56		
57		
58		
59		
60		
61		
62		
63		
64		
65		
66		
67		
68		
69		
70		
71		
72		
73		
74		
75		
76		
77		
78		
79		
80		
81		
82		
83		
84		
85		
86		
87		
88		
89		
90		
91		
92		
93		
94		
95		
96		
97		
98		
99		
100		

RED (LOW) BLACK (HIGH)
WHERE APPLICABLE

HARD MFG. CO.
4095-228 C

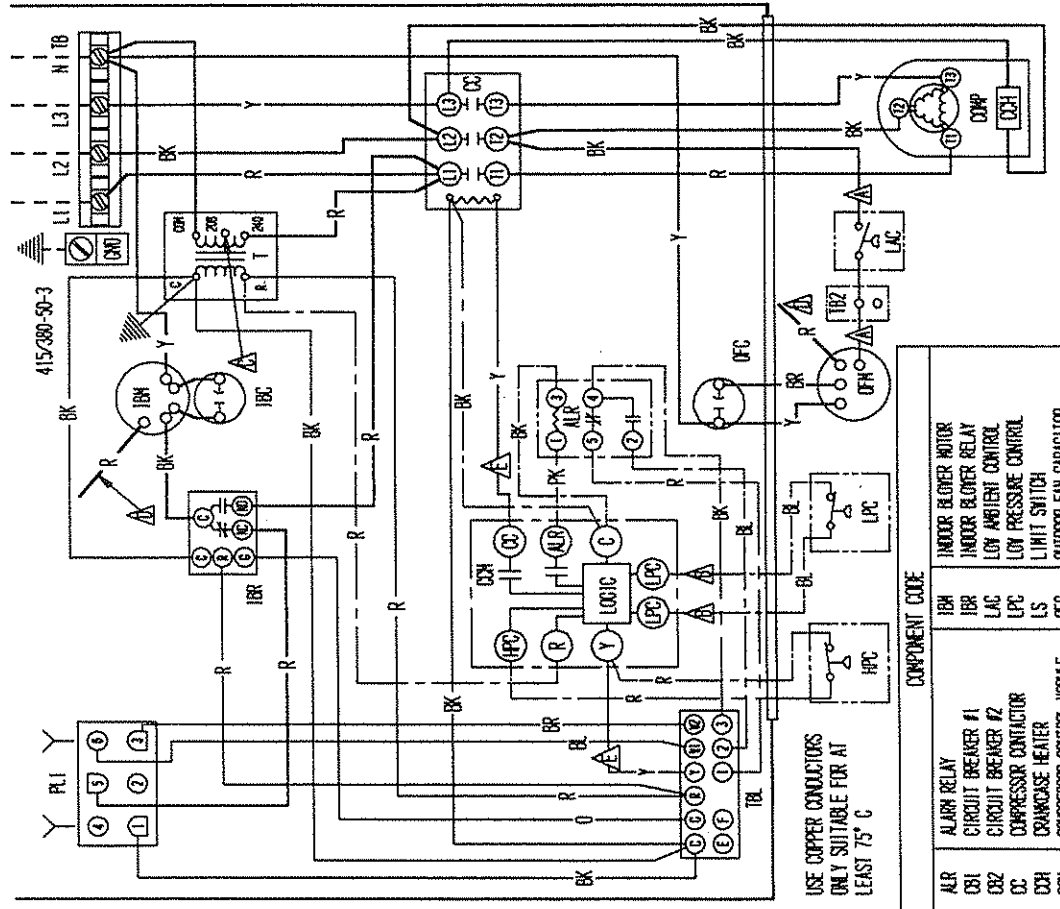
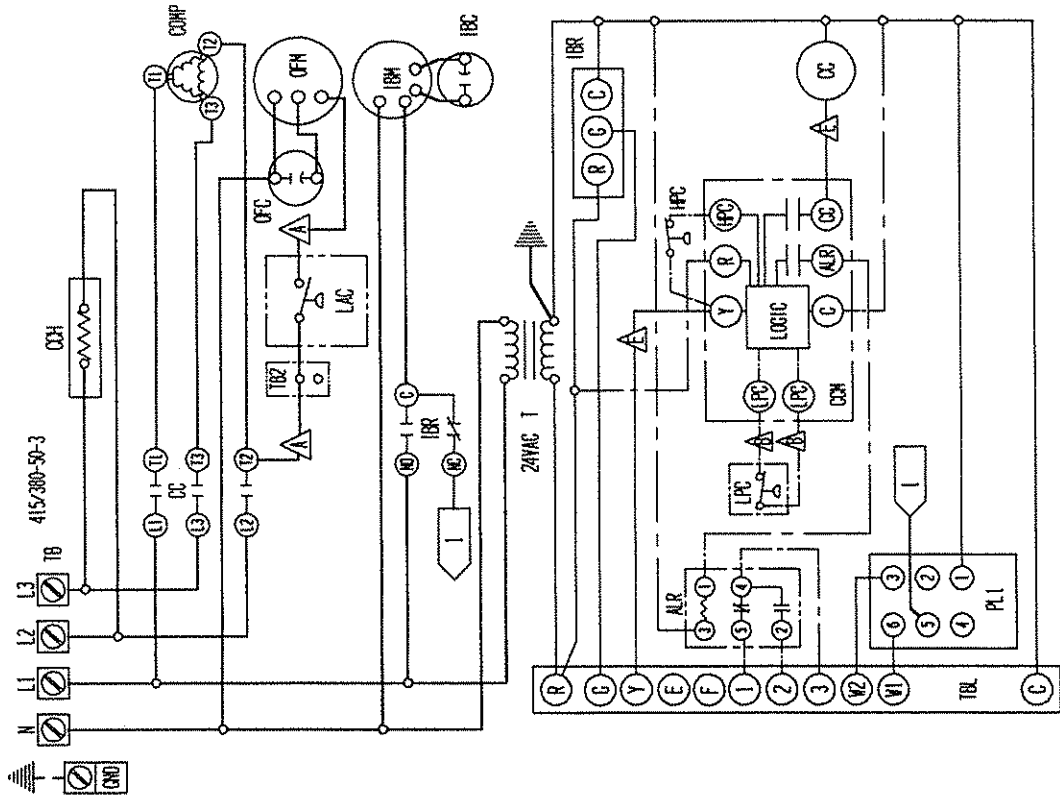

USE COPPER CONDUCTORS
ONLY SUITABLE FOR AT
LEAST 75 °C

COMPONENT CODE	
ALR	ALARM RELAY
CB1	CIRCUIT BREAKER #1
CB2	CIRCUIT BREAKER #2
CC	COMPRESSOR CONTACTOR
COH	COINTEGRATED HEATER
COH	COMPRESSOR CONTROL MODULE
COH	COMPRESSOR
END	EQUIPMENT GROUND
H1	HEAT STRIP #1
H2	HEAT STRIP #2
H2	HEATER CONTACTOR #1
H2	HEATER CONTACTOR #2
HPC	HIGH PRESSURE CONTROL
IBK	INDOOR BLOWER CAPACITOR
IBH	INDOOR BLOWER MOTOR
IBR	INDOOR BLOWER RELAY
LAC	LOW AMBIENT CONTROL
LPC	LOW PRESSURE CONTROL
LS	LIMIT SWITCH
OFC	OUTDOOR FAN CAPACITOR
OFC	OUTDOOR FAN MOTOR
PL1	PLUG #1
T	TRANSFORMER
TB, TB2	TERMINAL BLOCK
TBL	LOW VOLTAGE TERMINAL BLOCK
TCO	THERMAL CUTOFF

△, △, △ LABELLED WIRES CONNECT IF NO OPTIONS USED. △ MOVE RED WIRE TO 208V TAP FOR 300V OPERATION △ RED (LOW) BLACK (HIGH) WIRE APPLICABLE

FACTORY STD.	FIELD	OPTIONAL
HIGH VOLTAGE	---	---
LOW VOLTAGE	---	---
ACCESSORY	---	---

COLOR CODE		
BK	BLACK	YAN
BR	BROWN	PK
R	RED	L
O	ORANGE	---
Y	YELLOW	---
G	GREEN	---
BL	BLUE	---
W	WHITE	---
V	VIOLET	---
PK	PINK	---
PR	PURPLE	---
GY	GRAY	---
SL	SLATE	---

BARD MFG. CO.
4095-621 A