

**Installation
Instructions**

**Wall Mounted
Packaged Air Conditioner**

Models: WL251

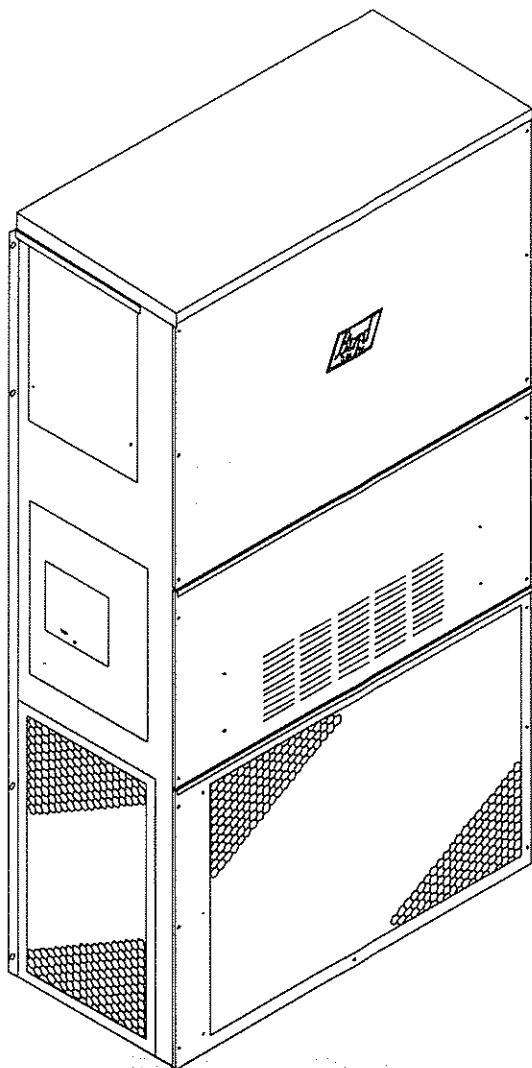

MIS-961



Bard Manufacturing Company
Bryan, Ohio 43506
*Since 1914...Moving ahead, just as
planned.*

Manual No.: 2100-336
File: Volume III, Tab 16
Date: 04-27-98

Contents

Getting Other Information	1
--	----------

Wall Mount General Information

Model Nomenclature	2
Shipping Damage	4
General	4
Duct Work	4
Filters	4
Fresh Air Intake	5
Condensate Drain	5

Installation Instructions

Wall Mounting Information	6
Mounting the Unit	6

Start Up

Important Installer Note	11
High Pressure Switch	11
Three Phase Scroll Compressor Start Up Information	11
Service Hints	11
Sequence of Operations	11
Compressor Control Module	11
Phase Monitor	12
Pressure Service Ports	12

Troubleshooting

Fan Blade Setting Dimensions	13
Removal of Fan Shroud	13
Refrigerant Charge	13

Figures

Figure 1	3
Figure 2	5
Figure 3	6
Figure 4	7
Figure 5	7
Figure 6	8
Figure 7	10
Figure 8	13

Tables

Table 1	2
Table 2	3
Table 3	9
Table 3A	9
Table 4	13
Table 5	13
Table 6	13
Table 7	13
Table 8	13
Table 9	14
Table 10	14

Getting Other Information and Publications

These publications can help you install the air conditioner or heat pump. You can usually find these at your local library or purchase them directly from the publisher. Be sure to consult current edition of each standard.

National Electrical Code ANSI/NFPA 70

Standard for the Installation ANSI/NFPA 90A
of Air Conditioning and
Ventilating Systems

Standard for Warm Air ANSI/NFPA 90B
Heating and Air
Conditioning Systems

Load Calculation for ACCA Manual J
Residential Winter and
Summer Air Conditioning

Duct Design for Residential ACCA Manual D
Winter and Summer Air
Conditioning and Equipment
Selection

For more information, contact these publishers:

ACCA — Air Conditioning Contractors of America
1712 New Hampshire Avenue NW
Washington, DC 20009
Telephone: (202) 483-9370
Fax: (202) 234-4721

ANSI — American National Standards Institute
11 West Street, 13th Floor
New York, NY 10036
Telephone: (212) 642-4900
Fax: (212) 302-1286

**ASHRAE — American Society of Heating Refrigerating, and
Air Conditioning Engineers, Incorporated**
1791 Tullie Circle, N.E.
Atlanta, GA 30329-2305
Telephone: (404) 636-8400
Fax: (404) 321-5478

NFPA — National Fire Protection Association
Batterymarch Park
P.O. Box 9101
Quincy, MA 02269-9901
Telephone: (800) 344-3555
Fax: (617) 984-7057

Wall Mount General Information

Air Conditioner Wall Mount Model Nomenclature

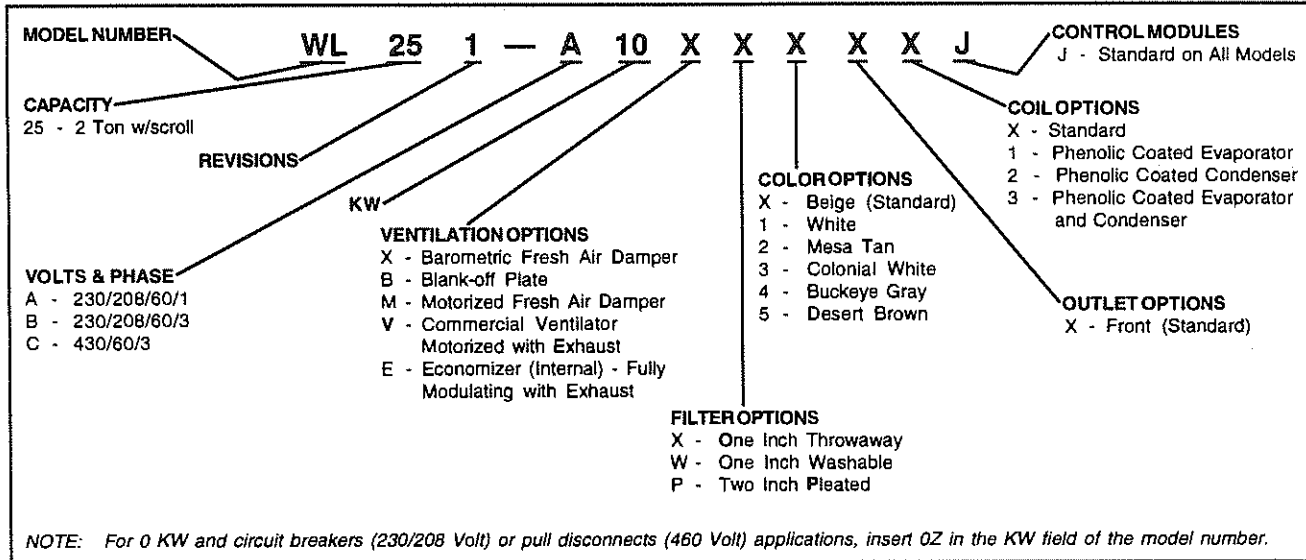

TABLE 1 – ELECTRICAL SPECIFICATIONS

SINGLE CIRCUIT						
Model	Rated Volts and Phase	Number Field Power Circuits	(3) Minimum Circuit Ampacity	(1) Maximum External Fuse or Circuit Breaker	(2) Field Power Wire Size	(2) Ground Wire Size
WL251-A0Z	230/208-1	1	20	25	10	10
A05		1	30	30	10	10
A08		1	45	45	8	10
A10		1	56	60	6	10
WL251-B0Z	230/208-3	1	14	20	12	12
B06		1	22	25	10	10

- (1) Maximum size of the time delay fuse or HACR type circuit breaker for protection of field wiring conductors.
- (2) Based on 75°C copper wire. All wiring must conform to NEC and all local codes.
- (3) These "Minimum Circuit Ampacity" values are to be used for sizing the field power conductors. Refer to the National Electric Code (latest revision), Article 310 for power conductor sizing. **Caution:** When more than one field power conductor circuit is run through one conduit, the conductors must be derated. Pay special attention to Note 8 of Table 310 regarding Ampacity Adjustment Factors when more than 3 conductors are in a raceway.

FIGURE 1 – UNIT DIMENSIONS

Unit	Width (W)	Depth (D)	Height (H)	Supply		Return		E	F	G	I	J	K	L	M	N	O	P	Q
				A	B	C	B												
WL251	32-7/8	16-7/8	70-1/2	7-7/8	19-7/8	11-7/8	19-7/8	34-7/8	18-1/4	25-3/4	20-3/4	26-3/4	28	29-1/4	27	2-9/16	34	22-1/16	10-1/2

All dimensions in inches

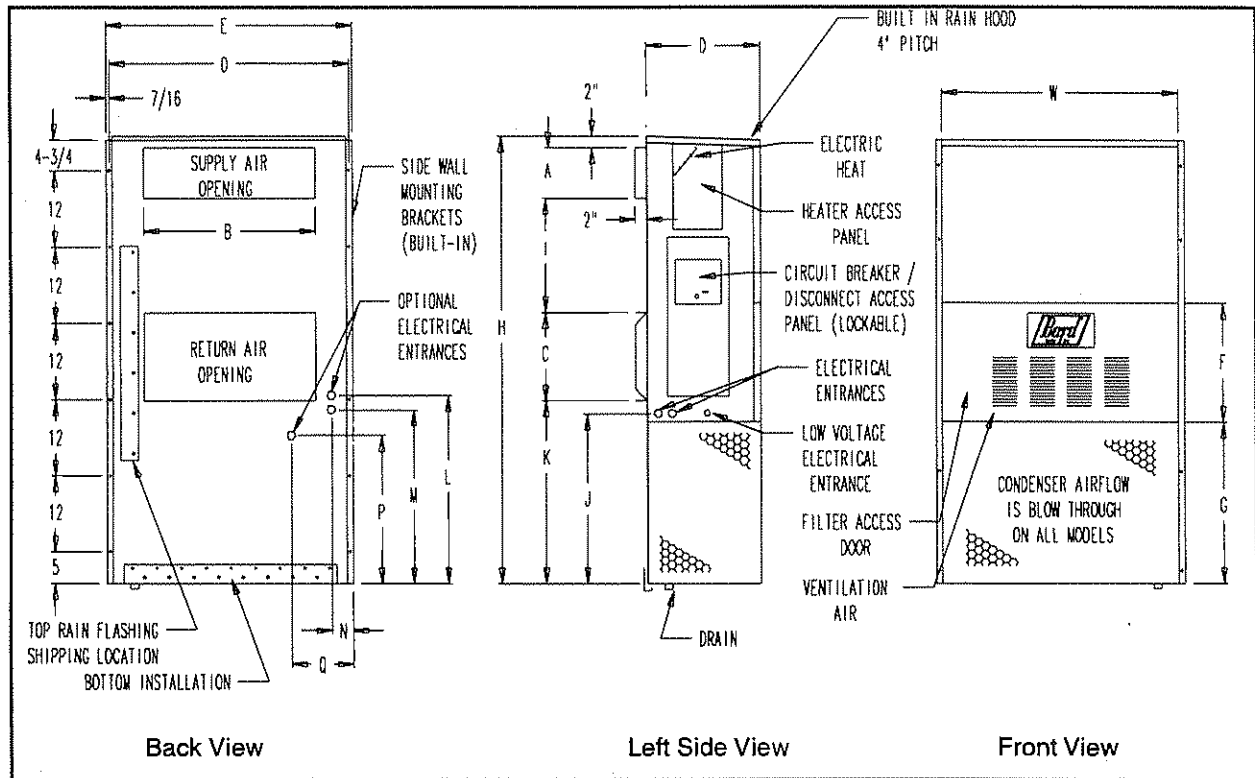

TABLE 2 – ELECTRIC HEAT TABLE

Models	WL251-A				WL251-B			
	240-1		208-1		240-3		208-3	
KW	A	BTU	A	BTU	A	BTU	A	BTU
5	20.8	17,065	18.1	12,800				
8	33.3	27,300	28.8	20,475				
10	41.6	34,130	36.2	25,600				
6					14.4	20,500	12.5	15,360

Shipping Damage

Upon receipt of equipment, the carton should be checked for external signs of shipping damage. If damage is found, the receiving party must contact the last carrier immediately, preferably in writing, requesting inspection by the carrier's agent.

General

The equipment covered in this manual is to be installed by trained, experienced service and installation technicians.

The refrigerant system is completely assembled and charged. All internal wiring is complete.

The unit is designed for use with or without duct work. Flanges are provided for attaching the supply and return ducts.

These instructions explain the recommended method to install the air cooled self-contained unit and the electrical wiring connections to the unit.

These instructions and any instructions packaged with any separate equipment required to make up the entire air conditioning system should be carefully read before beginning the installation. Note particularly "Starting Procedure" and any tags and/or labels attached to the equipment.

While these instructions are intended as a general recommended guide, they do not supersede any national and/or local codes in any way. Authorities having jurisdiction should be consulted before the installation is made. See Page 1 for information on codes and standards.

Size of unit for a proposed installation should be based on heat loss calculation made according to methods of Air Conditioning Contractors of America (ACCA). The air duct should be installed in accordance with the Standards of the National Fire Protection Association for the Installation of Air Conditioning and Ventilating Systems of Other Than Residence Type, NFPA No. 90A, and Residence Type Warm Air Heating and Air Conditioning Systems, NFPA No. 90B. Where local regulations are at a variance with instructions, installer should adhere to local codes.

Duct Work

All duct work, supply and return, must be properly sized for the design air flow requirement of the equipment. Air Conditioning Contractors of America (ACCA) is an excellent guide to proper sizing. All duct work or portions thereof not in the conditioned space should be properly insulated in order to both conserve energy and prevent condensation or moisture damage.

Refer to Table 8 for maximum static pressure available for duct design.

Design the duct work according to methods given by the Air Conditioning Contractors of America (ACCA). When duct runs through unheated spaces, it should be insulated with a minimum of one inch of insulation. Use insulation with a vapor barrier on the outside of the insulation. Flexible joints should be used to connect the duct work to the equipment in order to keep the noise transmission to a minimum.

A 1/4-inch clearance to combustible material for the first 3 feet of duct attached to the outlet air frame is required. See Wall Mounting Instructions and Figures 3 and 7 for further details.

Ducts through the walls must be insulated and all joints taped or sealed to prevent air or moisture entering the wall cavity.

CAUTION

Some installations may not require any return air duct. A metallic return air grille is required with installations not requiring a return air duct. The spacing between louvers on the grille shall not be larger than 5/8 inches.

Any grille that meets the 5/8 inch louver criteria may be used. It is recommended that Bard Return Air Grille Kit RG-2 thru RG-5 or RFG-2 thru RFG-5 be installed when no return duct is used. Contact distributor or factory for ordering information. If using a return air filter grille, filters must be of sufficient size to allow a maximum velocity of 400 fpm.

NOTE: If no return air duct is used, applicable installation codes may limit this cabinet to installation only in a single story structure.

Filters

A 1 inch throwaway filter is supplied with each unit. The filter slides into position making it easy to service. This filter can be serviced from the outside by removing the service door. A 1 inch washable filter and 2 inch pleated filter are also available as optional accessories. The internal filter brackets are adjustable to accommodate the 2 inch filter by bending the metal tabs holding the 1 inch filter down. There are two tabs on each side of the filter.

Fresh Air Intake

All units are built with fresh air inlet slots punched in the service panel.

If the unit is equipped with the fresh air damper assembly, the assembly is shipped already attached to the unit. The damper blade is locked in the closed position. To allow the damper to operate, the maximum and minimum blade position stops must be installed. See Figure 2.

All capacity, efficiency and cost of operation information as required for Department of Energy "Energyguide" Fact Sheets is based upon the fresh air blank-off plate in place and is recommended for maximum energy efficiency.

The blank-off plate is available upon request from the factory and is installed in place of the fresh air damper shipped with each unit.

Condensate Drain

A plastic drain hose extends from the drain pan at the top of the unit down to the unit base. There are openings in the unit base for the drain hose to pass through. In the event the drain hose is connected to a drain system of some type, it must be an open or vented type system to assure proper drainage.

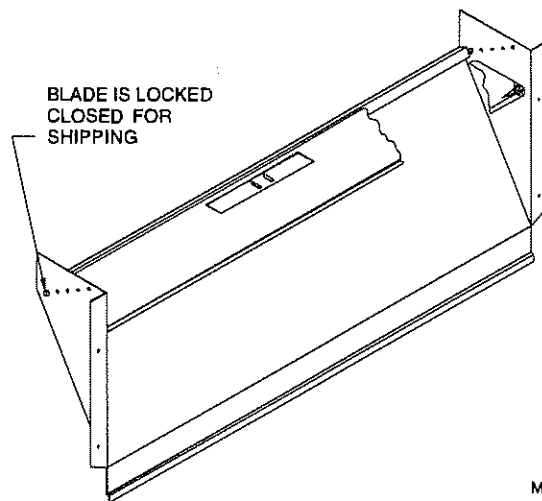

MIS-938

FIGURE 2 - FRESH AIR DAMPER ASSEMBLY

Installation Instructions

Wall Mounting Information

1. These units are secured by wall mounting brackets which secure the unit to the outside wall surface at both sides. A bottom mounting bracket is provided for ease of installation, but is not required.
2. On wood-frame walls, the wall construction must be strong and rigid enough to carry the weight of the unit without transmitting any unit vibration.
3. Concrete block walls must be thoroughly inspected to insure that they are capable of carrying the weight of the installing unit.

Mounting the Unit

1. Two holes for the supply and return air openings must be cut through the wall as shown in Figure 3.
2. Locate and mark lag bolt locations and bottom bracket location, if desired. See Figure 3.

3. Mount bottom mounting bracket, if used.
4. Hook top rain flashing under back bend of top. Top rain flashing is shipped attached to the back of the unit on the right side.
5. Position unit in opening and secure with 5/16 lag bolts; use 7/8-inch diameter flat washers on the lag bolts.
6. Secure rain flashing to wall and caulk across entire length of top. See Figure 3.
7. For additional mounting rigidity, the return air and supply air frames or collars can be drilled and screwed or welded to the structural wall itself (depending upon wall construction). Be sure to observe required clearance if combustible wall. Additional clearance may be required to meet local or national codes.
8. On side by side installations, maintain a minimum of 20 inches clearance on left side to allow access to heat strips and control panel and to allow proper airflow to the outdoor coil.

FIGURE 3 – MOUNTING INSTRUCTIONS

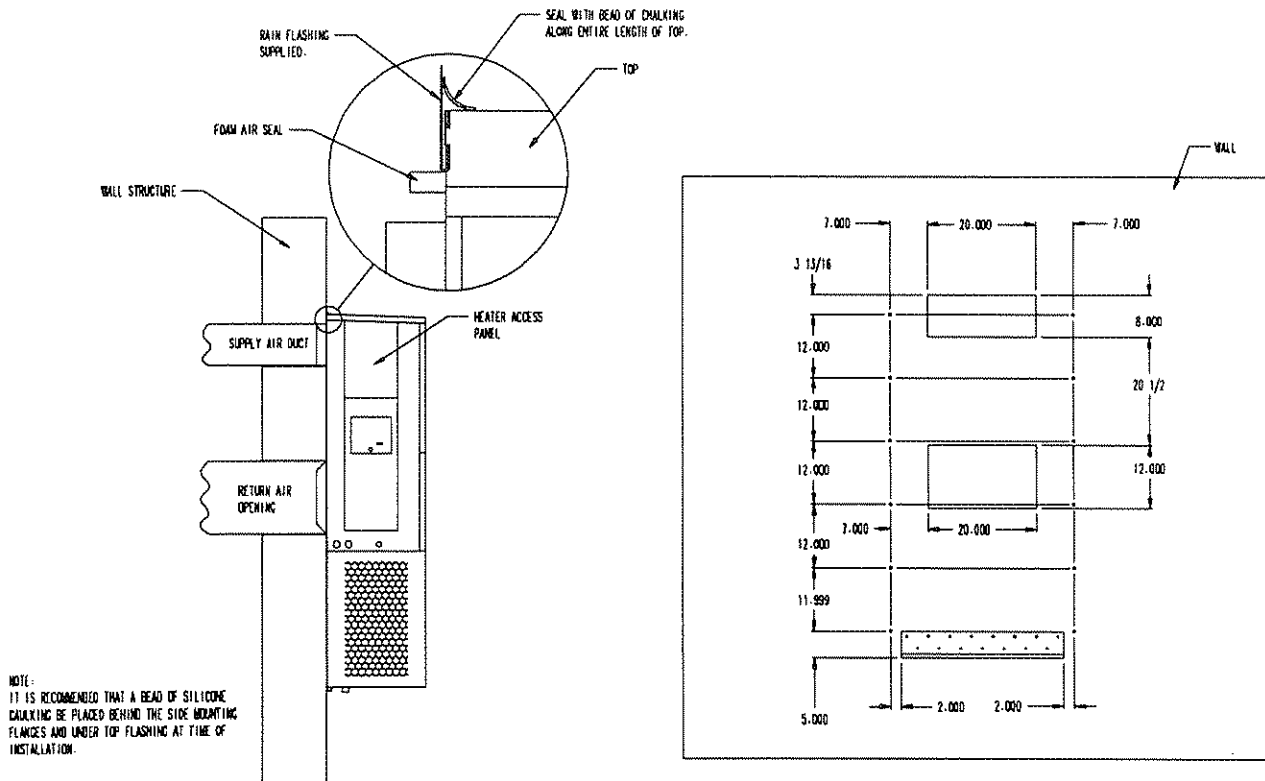

MIS-1045

FIGURE 4 – WALL-MOUNTING INSTRUCTIONS

SEE FIGURE 3 – MOUNTING INSTRUCTIONS FOR OPENING SIZES

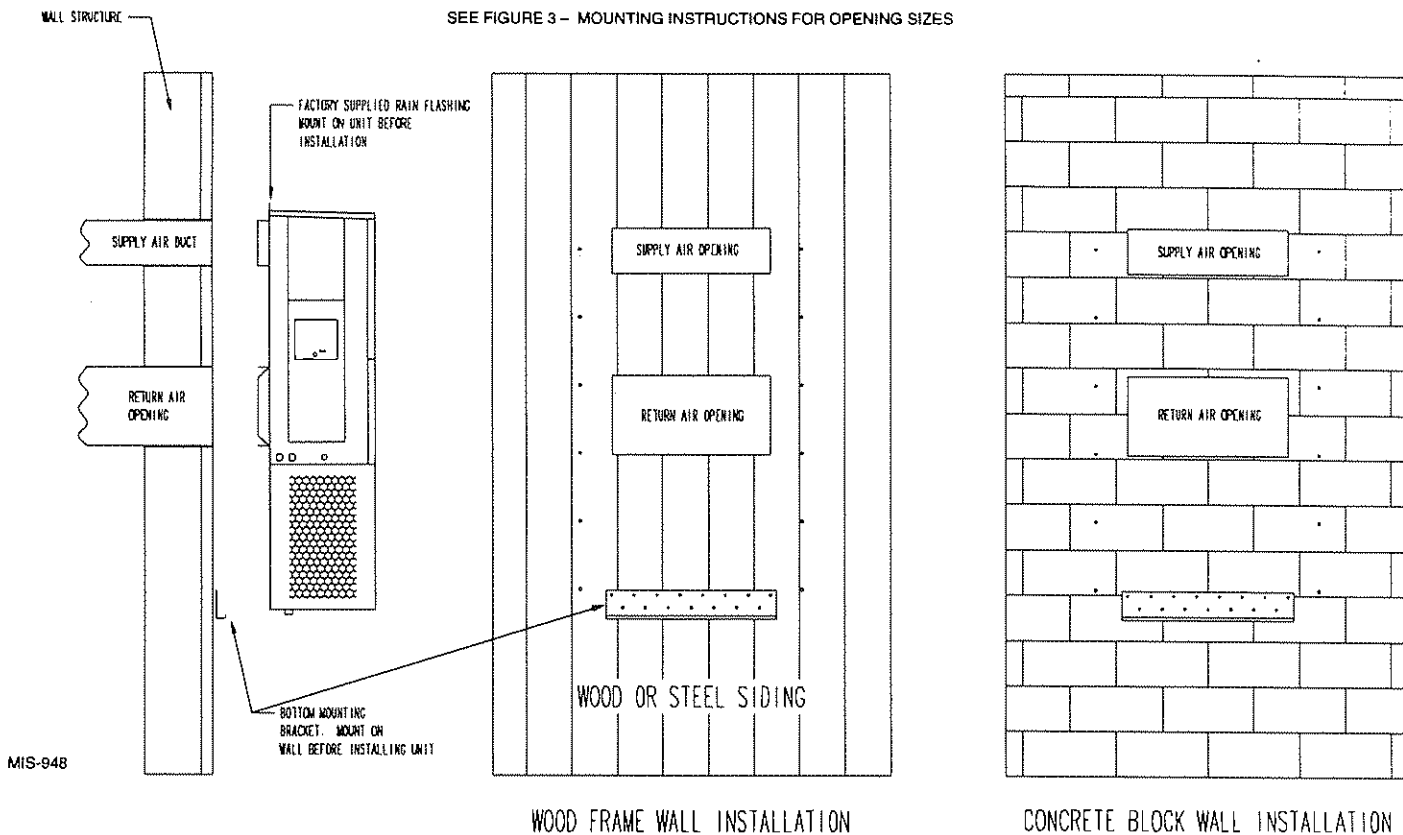

FIGURE 5 – WALL-MOUNTING INSTRUCTIONS

SEE UNIT DIMENSIONS FIGURE 1 FOR ACTUAL DIMENSIONS

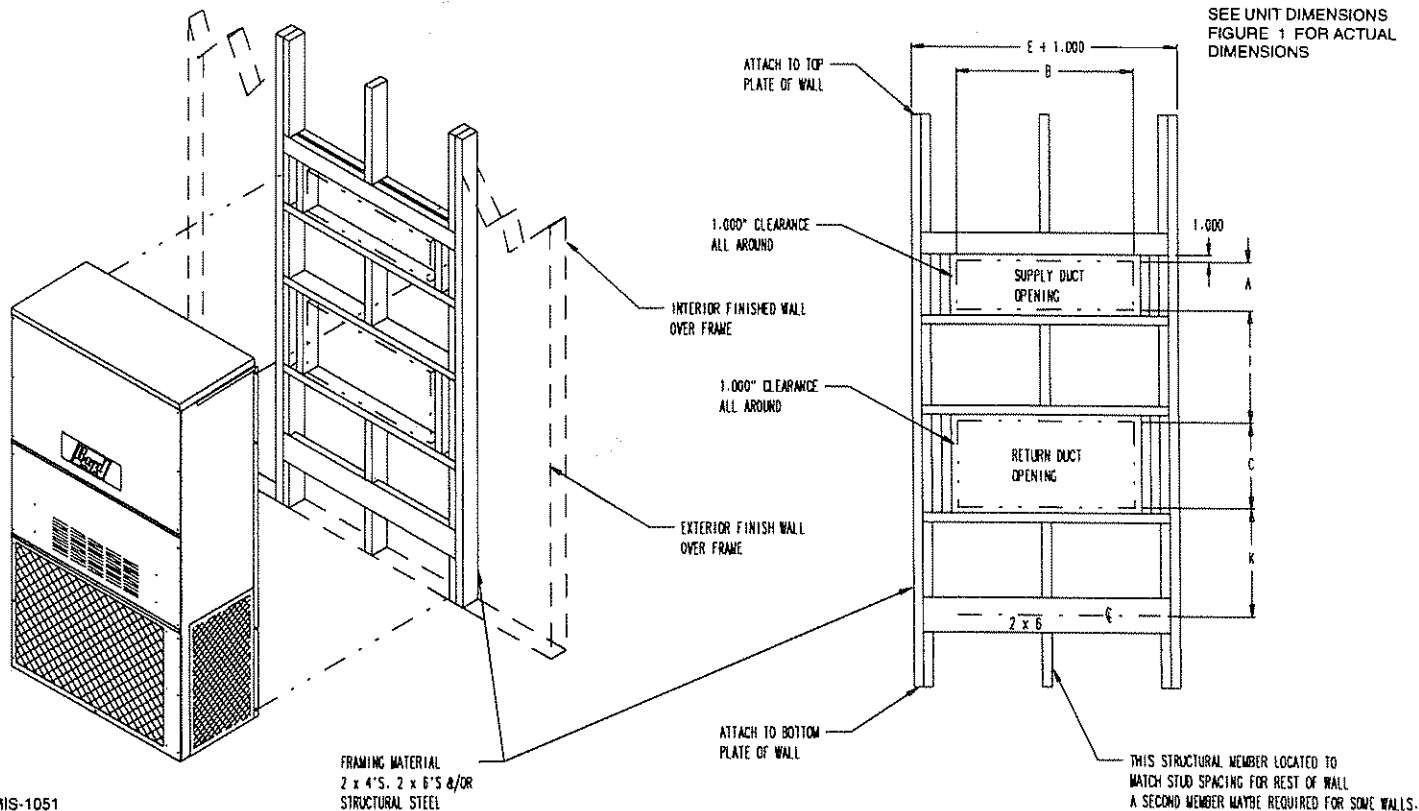
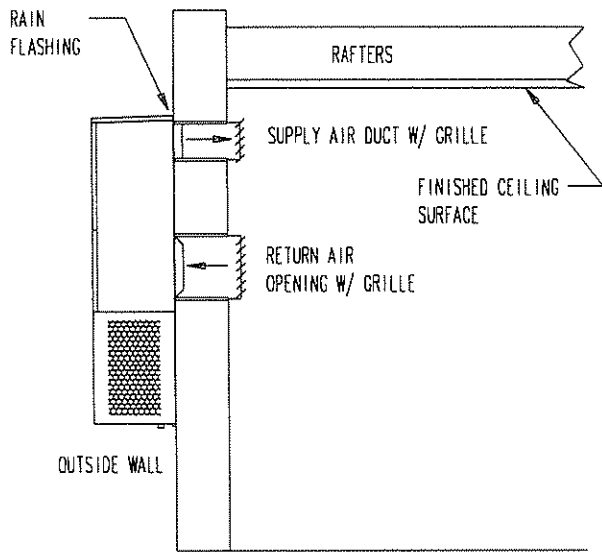
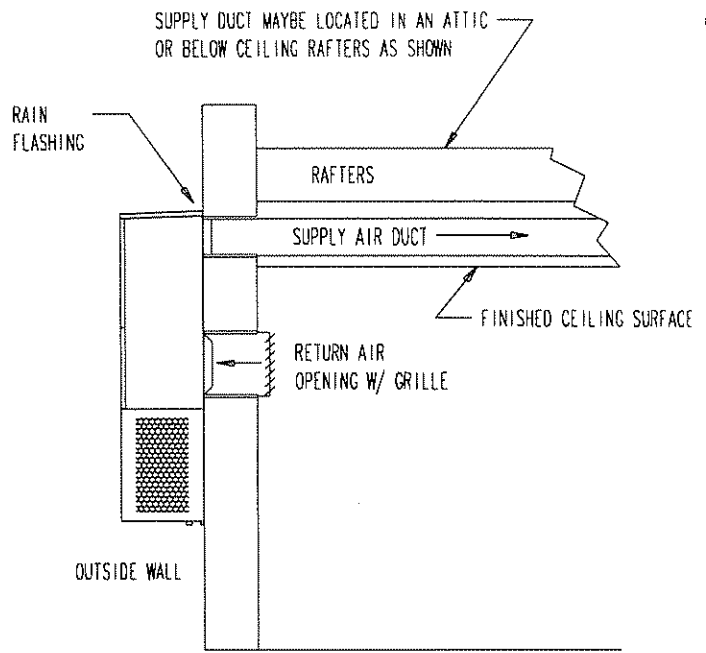

FIGURE 6 - COMMON WALL-MOUNTING INSTALLATIONS



FREE AIR FLOW
NO DUCT



DUCTED SUPPLY
RETURN AT UNIT

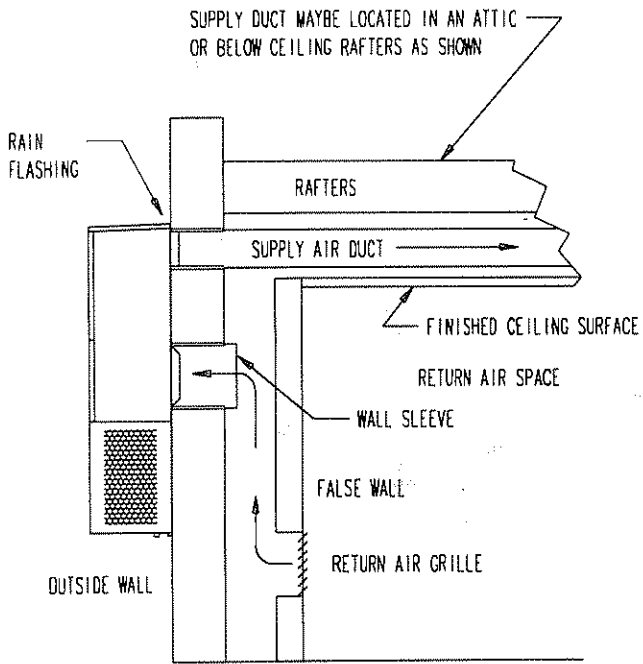

FALSE WALL INSTALLATION

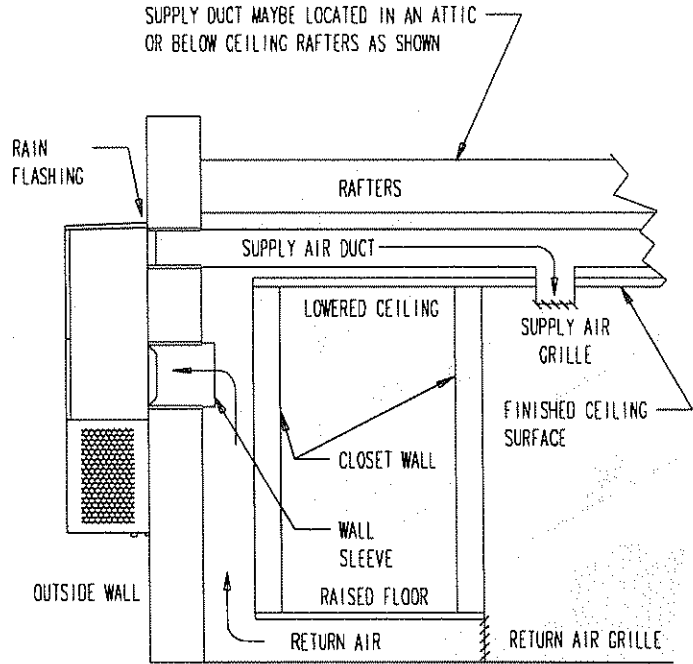

CLOSET INSTALLATION

MIS-1050

Wiring — Main Power

Refer to the unit rating plate for wire sizing information and maximum fuse or “HACR Type” circuit breaker size. Each outdoor unit is marked with a “Minimum Circuit Ampacity”. This means that the field wiring used must be sized to carry that amount of current. Depending on the installed KW of electric heat, there may be two field power circuits required. If this is the case, the unit serial plate will so indicate. All models are suitable only for connection with copper wire. Each unit and/or wiring diagram will be marked “Use Copper Conductors Only”. These instructions *must be* adhered to. Refer to the National Electrical Code (NEC) for complete current carrying capacity data on the various insulation grades of wiring material. All wiring must conform to NEC and all local codes.

The electrical data lists fuse and wire sizes (75°C copper) for all models, including the most commonly used heater sizes. Also shown are the number of field power circuits required for the various models with heaters.

The unit rating plate lists a “Maximum Time Delay Relay Fuse” or “HACR Type” circuit breaker that is to be used with the equipment. The correct size must be used for proper circuit protection and also to assure that there will be no nuisance tripping due to the momentary high starting current of the compressor motor.

The disconnect access door on this unit may be locked to prevent unauthorized access to the disconnect. To convert for the locking capability, bend the tab located in the bottom left hand corner of the disconnect opening under the disconnect access panel straight out. This tab will now line up with the slot in the door. When shut, a padlock may be placed through the hole in the tab preventing entry.

Wiring — Low Voltage Wiring

230/208V – 1 phase and 3 phase equipment dual primary voltage transformers. All equipment leaves the factory wired on 240V tap. For 208V operation, reconnect from 240V to 208V tap. The acceptable operating voltage range for the 240V and 208V taps are:

<u>TAP</u>	<u>RANGE</u>
240	253 – 216
208	220 – 187

NOTE: The voltage should be measured at the field power connection point in the unit and while the unit is operating at full load (maximum amperage operating condition).

Five (5) wires should be run from thermostat subbase to the 24V terminal board in the unit. A five conductor, 18 gauge copper, color-coded thermostat cable is recommended. The connection points are shown in Figure 8.

TABLE 3 – THERMOSTAT WIRE SIZE

Transformer VA	FLA	Wire Gauge	Maximum Distance in Feet
55	2.3	20 Gauge	45
		18 Gauge	60
		16 Gauge	100
		14 Gauge	160
		12 Gauge	250

TABLE 3A – WALL THERMOSTAT and SUBBASE COMBINATIONS

Thermostat	Subbase	Predominate Features
8403-002 T87F3111	8404-003 Q539A1220	1 stage heat, 1 stage cool System: heat-off-cool Fan: auto-on
8403-041 T8034C	---	1 stage heat, 1 stage cool System: heat-off-cool Fan: auto-on
8403-019 T874C1760	8404-012 Q674A1001	1 stage cool, 2 stage heat System: heat-auto-cool Fan: auto-on
8403-021 T874D1934	8404-012 Q674A1001	2 stage cool, 2 stage heat System: heat-auto-cool Fan: auto-on
8403-035 1F95-80	---	2 stage cool, 2 stage heat Electronic 7 day programming

**FIGURE 7
LOW VOLTAGE WIRING DIAGRAM**

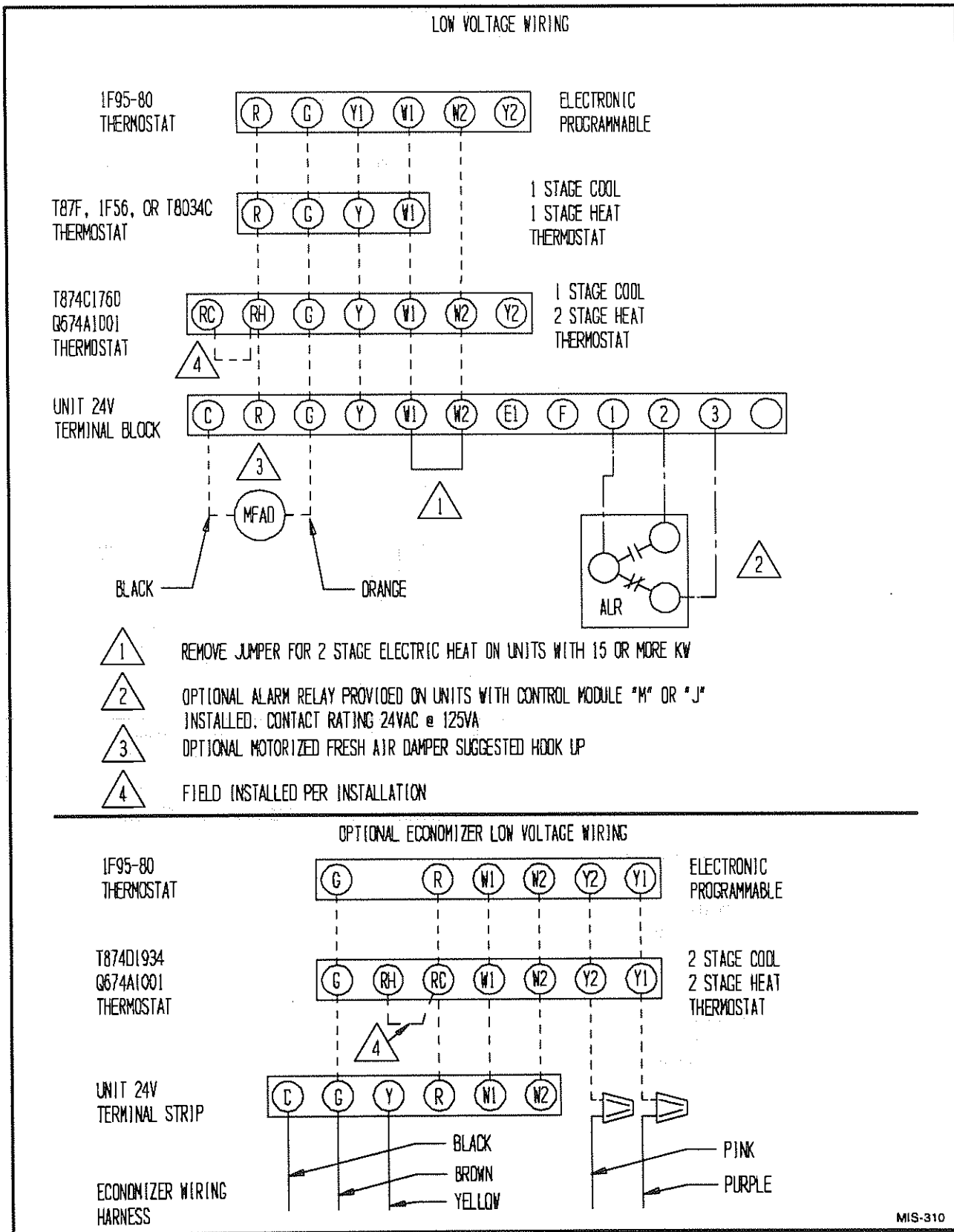

IMPORTANT INSTALLER NOTE

For improved start-up performance, wash the indoor coil with a dishwasher detergent.

HIGH PRESSURE SWITCH

The WL251 models are supplied with a remote reset high pressure switch. If tripped, this pressure switch may be reset by turning the thermostat off then back on again.

THREE PHASE SCROLL COMPRESSOR START UP INFORMATION

Scroll compressors, like several other types of compressors, will only compress in one rotational direction. Direction of rotation is not an issue with single phase compressors since they will always start and run in the proper direction.

However, three phase compressors will rotate in either direction depending upon phasing of the power. Since there is a 50-50 chance of connecting power in such a way as to cause rotation in the reverse direction, verification of proper rotation must be made. All three phase units incorporate a phase monitor to ensure proper field wiring. See the *Phase Monitor* section later in this manual.

Verification of *proper rotation* must be made any time a compressor is changed or rewired. If improper rotation is corrected at this time there will be no negative impact on the durability of the compressor. However, reverse operation for over one hour may have a negative impact on the bearing due to oil pump out.

NOTE: If compressor is allowed to run in reverse rotation for several minutes, the compressor's internal protector will trip.

All three phase ZR3 compressors are wired identical internally. As a result, once the correct phasing is determined for a specific system or installation, connecting properly phased power leads to the same Fusite terminal should maintain proper rotation direction.

Verification of proper rotation direction is made by observing that suction pressure drops and discharge pressure rises when the compressor is energized. Reverse rotation also results in an elevated sound level over that with correct rotations, as well as, substantially reduced current draw compared to tabulated values.

The direction of rotation of the compressor may be changed by reversing any two line connections to the unit.

SERVICE HINTS

1. Caution homeowner to maintain clean air filters at all times. Also, not to needlessly close off supply and return air registers. This reduces air flow through the system, which shortens equipment service life as well as increasing operating costs.
2. Check all power fuses or circuit breakers to be sure they are the correct rating.
3. Periodic cleaning of the outdoor coil to permit full and unrestricted airflow circulation is essential.

SEQUENCE OF OPERATION

COOLING—Circuit R-Y makes at thermostat pulling in compressor contactor, starting the compressor and outdoor motor. The G (indoor motor) circuit is automatically completed on any call for cooling operation or can be energized by manual fan switch on subbase for constant air circulation.

HEATING—Circuit R-W1 make at the thermostat pulling in heat contact for the strip heat and blower operation. On a call for second stage heat, R-W2 makes bringing on second heat contactor, if so equipped.

COMPRESSOR CONTROL MODULE

The compressor control is an anti-short cycle/lockout timer with high and low pressure switch monitoring and alarm relay output.

ADJUSTABLE DELAY ON MAKE AND BREAK TIMER

On a call for compressor operation the *delay on make* period begins which will be 10% of the *delay on break* setting. When the delay on make is complete and the high pressure switch (and low pressure switch if employed) is closed, the compressor contactor is energized. Upon shutdown the delay or break timer starts and prevents restart until the delay on break and delay on make periods have expired.

HIGH PRESSURE SWITCH AND LOCKOUT SEQUENCE

If the high pressure switch opens, the compressor contactor will de-energize immediately. The lockout timer will go into a *soft lockout* and stay in soft lockout until the high pressure switch closes and the delay on make time has expired. If the high pressure switch opens again in this same operating cycle the unit will go into *manual lockout* condition and the alarm relay circuit will energize. Recycling the wall thermostat resets the manual lockout.

LOW PRESSURE SWITCH, BYPASS, AND LOCKOUT SEQUENCE

If the low pressure switch opens for more than 120 seconds, the compressor contactor will de-energize and go into a soft lockout. Regardless the state of the low pressure switch, the contactor will reenergize after the delay on make time delay has expired. If the low pressure switch remains open, or opens again for longer than 120 seconds the unit will go into manual lockout condition and the alarm relay circuit will energize. Recycling the wall thermostat resets the manual lockout.

ALARM RELAY OUTPUT

Alarm terminal is output connection for applications where alarm relay is employed. This terminal is powered whenever compressor is locked out due to HPC or LPC sequences as described.

NOTE: Both high and low pressure switch controls are inherently automatic reset devices. The high pressure switch and low pressure switch cut out and cut in settings are fixed by specific air conditioner or heat pump unit model. The lockout features, both soft and manual, are a function of the Compressor Control Module

ADJUSTMENTS

ADJUSTABLE DELAY ON MAKE AND DELAY ON BREAK TIMER

The potentiometer is used to select Delay on Break time from 30 seconds to 5 minutes. Delay on Make (DOM) timing is equal to 10% of Delay on Break (DOB) setting:

0.5 minute	(30 seconds)	DOB =	3 second	DOM
1.0 minute	(60 seconds)	DOB =	6 second	DOM
2.0 minute	(120 seconds)	DOB =	12 second	DOM
3.0 minute	(160 seconds)	DOB =	18 second	DOM
4.0 minute	(240 seconds)	DOB =	24 second	DOM
5.0 minute	(300 seconds)	DOB =	30 second	DOM

TYPICAL SETTINGS FOR DUAL UNIT INSTALLATION:

Unit No. 1: DOB set at 2 minutes, and DOM is 12 seconds

Unit No. 2: DOB set at 4 minutes, and DOM is 24 seconds.

PHASE MONITOR

All units with three phase compressors are equipped with a 3 phase line monitor to prevent compressor damage due to phase reversal.

The phase monitor in this unit is equipped with two LEDs. If the Y signal is present at the phase monitor and phases are correct the green LED will light.

If phases are reversed, the red fault LED will be lit and compressor operation is inhibited.

If a fault condition occurs, reverse two of the supply leads to the unit. Do not reverse any of the unit factory wires as damage may occur.

PRESSURE SERVICE PORTS

High and low pressure service ports are installed on all units so that the system operating pressures can be observed. Pressure tables can be found later in the manual covering all models. It is imperative to match the correct pressure table to the unit by model number.

Troubleshooting

Fan Blade Setting Dimensions

Shown in the drawing below are the correct fan blade setting dimensions for proper air delivery across the outdoor coil.

Any service work requiring removal or adjustment in the fan and/or motor area will require that the dimensions below be checked and blade adjusted in or out on the motor shaft accordingly.

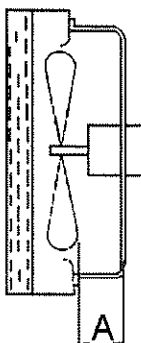

Figure 8 – Fan Blade Setting

TABLE 4 – FAN BLADE DIMENSIONS

Model	Dimension A
WL251	1.00

Removal of Fan Shroud

1. Disconnect all power to unit.
2. Remove the screws holding both grills – one on each side of unit – and remove grills.
3. Remove screws holding fan shroud to condenser and bottom – 9 screws.
4. Unwire condenser fan motor.
5. Slide complete motor, fan blade, and shroud assembly out the right side of the unit.
6. Service motor/fan as needed.
7. Reverse steps to reinstall.

Refrigerant Charge

The correct system R-22 charge is shown on the unit rating plate. Optimum unit performance will occur with a refrigerant charge resulting in a suction line temperature 6 inches from compressor) as shown in Table 5.

TABLE 5 – SUCTION LINE TEMPERATURES

Model	Rated Airflow	95 F OD Temperature	82 F OD Temperature
WL251	800	54 - 56	61 - 63

The above suction line temperatures are based upon 80°F dry bulb/67°F wet bulb (50 percent R.H.) temperature and rated airflow across the evaporator during cooling cycle.

TABLE 6 – INDOOR BLOWER PERFORMANCE – CFM at 230V

E.S.P. in H ₂ O	WL251	
	230V	
	Dry	Wet
.0	1020	975
.1	960	905
.2	865	800
.3	820	735
.4	735	650
.5	615	535

TABLE 7 – CFM and ESP

Model	Rated CFM *	Rated ESP *	Recommended Airflow Range
WL251	800	.20	700 - 950

* Rated CFM and EXP on high speed tap.

TABLE 8 – MAXIMUM ESP of OPERATION ELECTRIC HEAT ONLY

Model	ESP	
WL251	A0Z	.50
	A05	.50
	A08	.50
	A10	.50
WL251	B00	.50
	B06	.50

Values shown are for units equipped with standard 1" throw-away filter or 1" washable filter. Derate ESP by .15 for 2" pleated filters.

TABLE 9 – COOLING PRESSURE – OUTDOOR TEMPERATURE °F

Model	Return Air Temperature	Pressure	75	80	85	90	95	100	105	110	115
WL251	75 DB 62 WB	Low Side	68	70	72	74	75	77	78	79	79
		High Side	207	221	236	252	268	286	304	323	342
	80 DB 67 WB	Low Side	73	75	77	79	80	82	83	84	85
		High Side	212	227	242	258	275	293	312	331	351
	85 DB 72 WB	Low Side	76	78	80	82	83	85	86	87	88
		High Side	219	235	250	267	285	303	323	343	363

Low side pressure ± 2 PSIG

High side pressure ± 5 PSIG

Table based upon rated CFM (airflow) across the evaporator coil and should be found under section titled "Refrigerant Charge" elsewhere in manual. If there is any doubt as to correct operating charge being in the system, the charge should be removed, system evacuated, and recharged to serial plate instructions.

TABLE 10 – OPTIONAL ACCESSORIES

Part Number	Description	WL251-A	WL251-B
BOP-2	Blank Off Plate	X	X
BFAD-2	Barometric Fresh Air Damper	X	X
MFAD-2	Motorized Fresh Air Damper	X	X
CRV-2	Commercial Room Ventilator	X	X
EIFM-2	Economizer with Exhaust	X	X
CMC-15	Start Kit	X	N/A

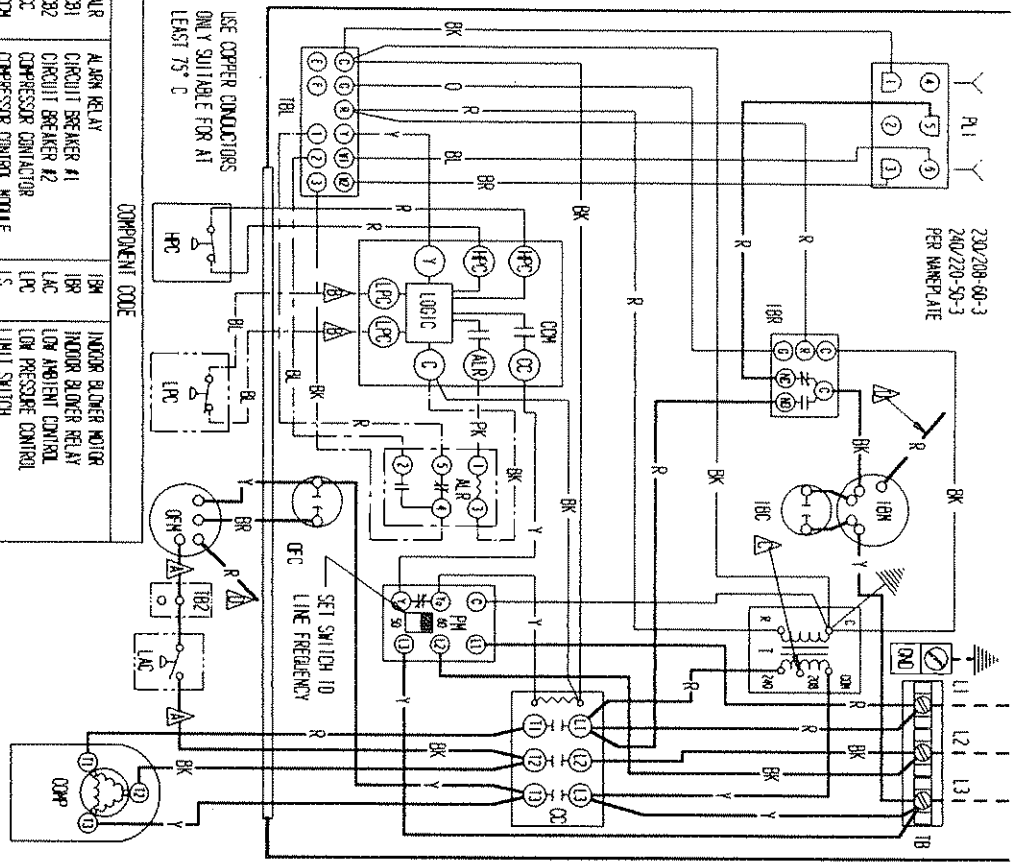

230/208-60-3
240/220-50-3
PER WAREPLATE

230/208-60-3
220/200-50-3
PER WAREPLATE

COMPONENT CODE	DESCRIPTION
ALR	ALARM RELAY
CB1	CIRCUIT BREAKER #1
CB2	CIRCUIT BREAKER #2
CC	COMPRESSOR CONTACTOR
CCM	COMPRESSOR CONTROL MODULE
CCP	COMPRESSOR
COU	EQUIPMENT COUPLER
HI	HEAT STRIP #1
H2	HEAT STRIP #2
H1	HEATER CONTACTOR #1
H2	HEATER CONTACTOR #2
HPC	HIGH PRESSURE CONTROL
HBC	INDOOR BLOWER CAPACITOR
IBM	INDOOR BLOWER MOTOR
IBR	INDOOR BLOWER RELAY
LAC	LOW AMBIENT CONTROL
LPC	LOW PRESSURE CONTROL
LS	LIMIT SWITCH
OFC	OUTDOOR FAN CAPACITOR
OFH	OUTDOOR FAN MOTOR
PLD #1	PLATE #1
PH	PHASE MONITOR
PH1	TRANSFORMER
T	TERMINAL BLOCK
TB, TB2	TERMINAL BLOCK
TR	LOW VOLTAGE TERMINAL BLOCK
YCO	THERMAL CUTOFF

▲ Labeled wires connect if no options used. ▲ Move red wire to 208V tap for 208V operation. ▲ Red (low) black (high) wire applicable.

FACTOR SIZ.	FIELD	OPTIONAL
High Voltage	---	---
Low Voltage	---	---
Accessory	---	---

COLOR CODE	WIRE COLOR
BR	BLACK
BR	BROWN
R	RED
OR	ORANGE
Y	YELLOW
C	GREEN
BL	BLUE
W	WHITE
V	(PR) VIOLET
GR	GRAY
SL	SLATE
T	TR
PK	PINK
L	LAURENCE

4095-227
BARD MFG. CO.