

IF ANY OF THE ORIGINAL WIRE AS SUPPLIED WITH THE APPLIANCE MUST BE REPLACED, IT MUST BE REPLACED WITH WIRING MATERIAL HAVING A TEMPERATURE RATING OF AT LEAST 105°C EXCEPT THE IGNITION CABLE WHICH IS 250° HIGH VOLTAGE CABLE.

COLOR CODE	
BK	BLACK
BL	BLUE
BR	BROWN
GR	GRAY
O	ORANGE
PR	PURPLE
RED	RED
W	WHITE
Y	YELLOW

COMPONENT CODE	
CB	CIRCUIT BREAKER
COMP	COMPRESSOR
CC	COMPRESSOR CONTACTOR
CCM	COMP. CONTROL MODULE
CR1	CONTROL RELAY #1
CR2	CONTROL RELAY #2
CR3	CONTROL RELAY #3
FCB	FURNACE CONTROL BOARD
FR	FLAME ROLLOUT
FS	FLAME SENSOR
FT	FREEZE THERMOSTAT
GND	GROUND
GV	GAS VALVE
HPC	HIGH PRESSURE CONTROL
HSBR	HIGH SPEED BLOWER RELAY
IBC	INDOOR BLOWER CAPACITOR
IBM	INDOOR BLOWER MOTOR
IDB	INDUCED DRAFT BLOWER
LAC	LOW AMBIENT CONTROL
LPC	LOW PRESSURE CONTROL
LSBR	LOW SPEED BLOWER RELAY
MSBR	MEDIUM SPEED BLOWER RELAY
OFC	OUTDOOR FAN CAPACITOR
OFM	OUTDOOR FAN MOTOR
PL1	2 PIN PLUG
PM	PHASE MONITOR
PRL	PRIMARY LIMIT
PS	PRESSURE SWITCH
RAT	RETURN AIR THERMOSTAT
SI	SPARK IGNITER
SL	SECONDARY LIMIT
SV	SOLENOID VALVE
T	TRANSFORMER
TB	TERMINAL BLOCK
TDR1	TIME DELAY RELAY #1
TDR2	TIME DELAY RELAY #2
TS	TERMINAL STRIP

USE COPPER CONDUCTORS SUITABLE FOR AT LEAST 75°C

WIRING CODE	
460 VAC	FACTORY ————
460 VAC	FIELD - - - - -
24 VAC	FACTORY ————
24 VAC	FIELD - - - - -

**⚠ DANGER**  
 \* ELECTRIC SHOCK HAZARD  
 \* DISCONNECT POWER BEFORE SERVICING

BLOWER SPEED COLOR CODE	
HIGH	BLACK
MEDIUM	BLUE
LOW	RED
ISOLATION	ORANGE
ISOLATION	PURPLE
COMMON	YELLOW

⚠ SWITCHING IS AUTOMATICALLY PERFORMED BY THE BLOWER RELAYS, BUT "BLACK" BLOWER LEAD MUST CONNECT TO "ORANGE" BLOWER LEAD FOR MEDIUM AND LOW SPEED BLOWER OPERATION, AND "PURPLE" BLOWER LEAD MUST CONNECT TO "BLUE" BLOWER LEAD FOR LOW SPEED BLOWER OPERATION. BLOWER SPEED-CHANGE WIRING IS ALL COMPLETED ON THE INTEGRATED FURNACE CONTROL BOARD USING THE "COOL", "HEAT", AND "UNUSED" TAPS.

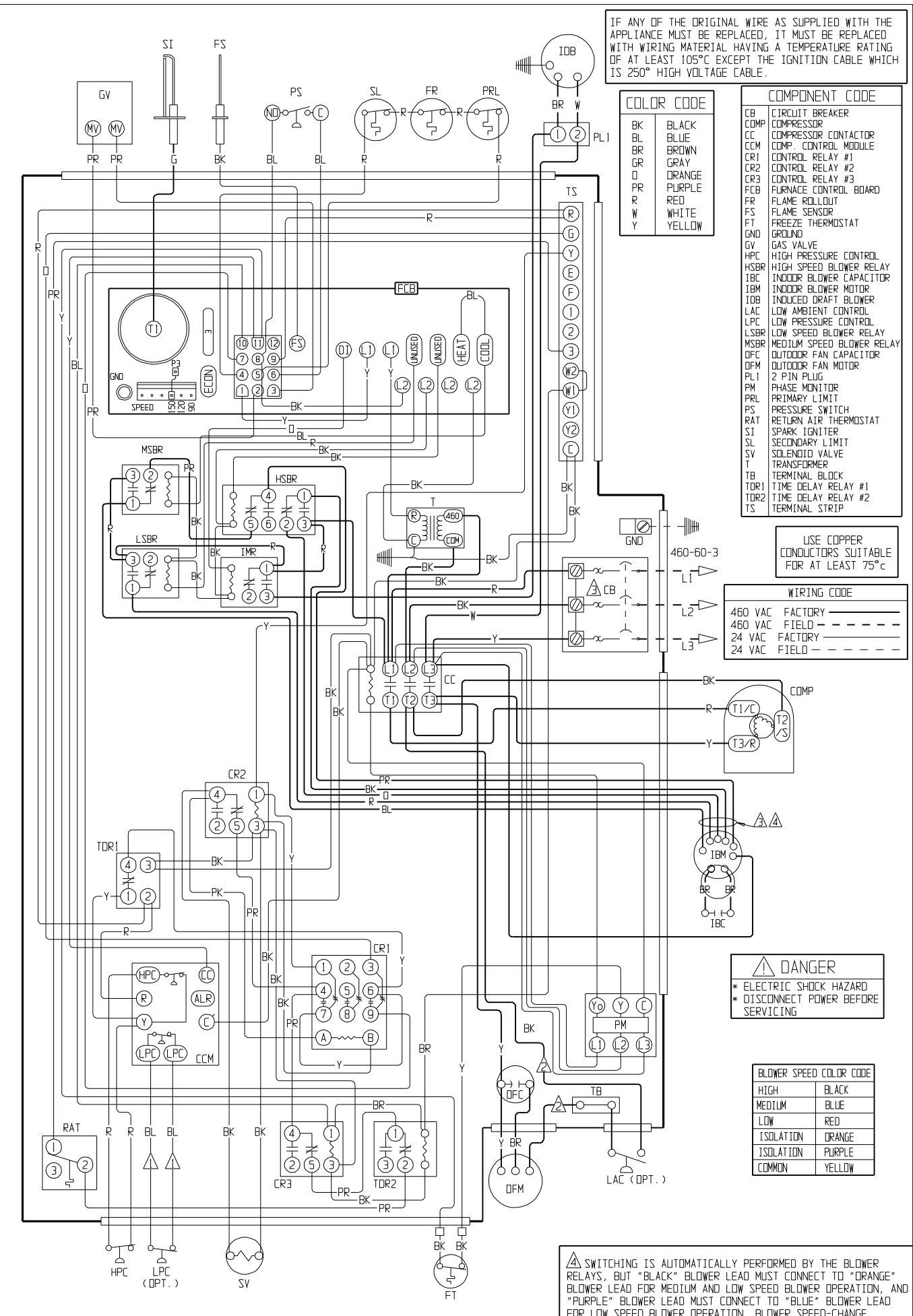

⚠ Labeled wires connect if no options used	⚠ MODEL W6424	COOL	HEAT	C. BREAKER
		MED.	MED.	15 A