

⚠ If there is an X1 and X2 terminal on Q674L1181, jumper them together and connect from C to either one.

⚠ For 208V operation move this wire to 208V transformer tap.

T872N1036/Q672F1299
or
T874N1024/Q674F1261

T872R1164/Q672L1185
or
T874R1129/Q674L1181

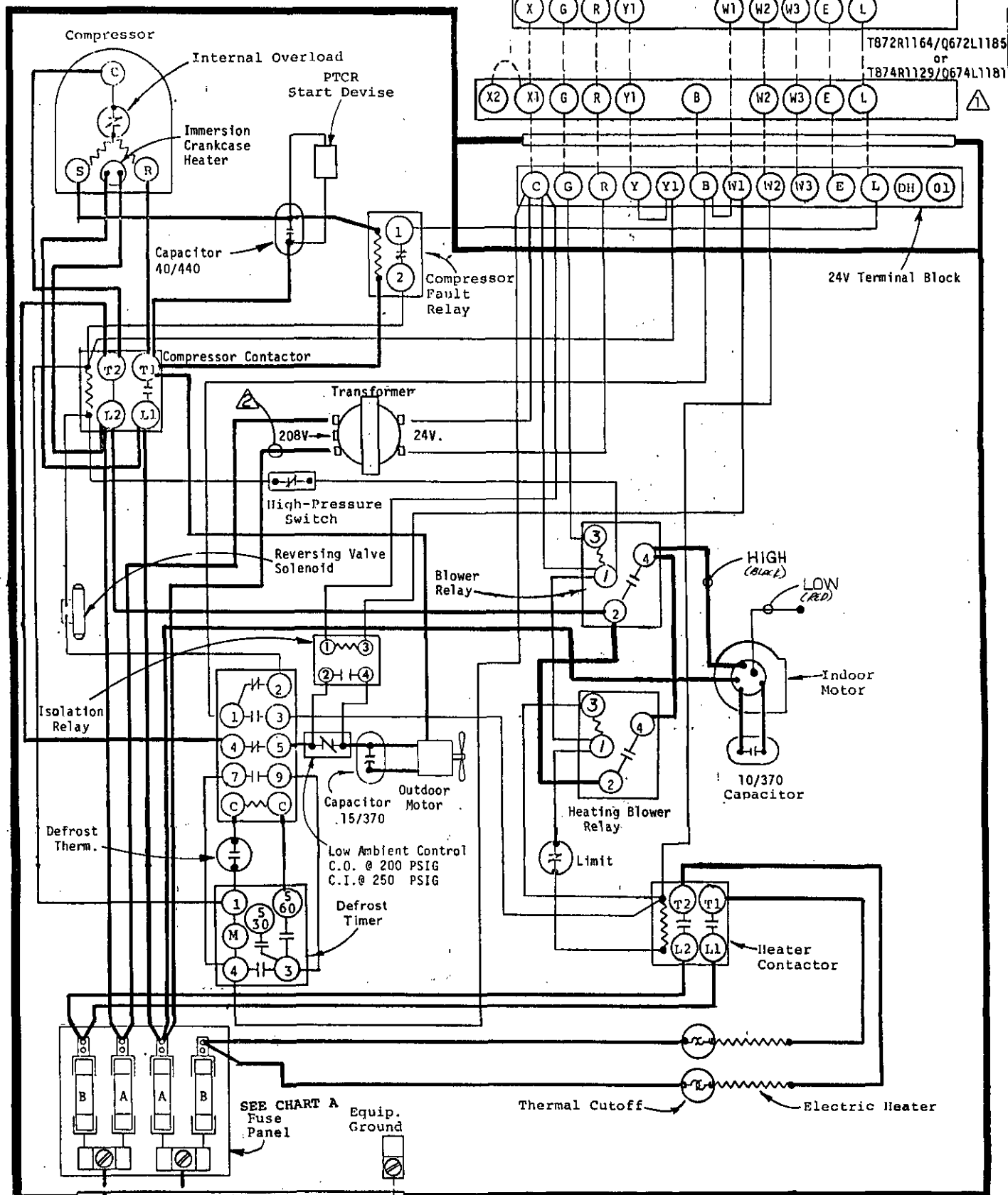

230/208-60-1

SEE CHART A
Fuse Panel

USE COPPER OR ALUMINUM WIRE

CHART A	42WH	48WH5
Fuse A	50A Time Delay	60A Time Delay
Fuse B	60A Standard	

ALL FUSES CLASS K5

	FACTORY WIRING	FIELD WIRING
Low Voltage	_____	-----
High Voltage	_____	-----

MODEL
42WH, 48WH5
HEAT PUMP
10 Kw