

⚠ If there is an X1 and X2 terminal on Q674L1181, jumper them together and connect from C to either one.

T872N1036/Q672F1299
or
T874N1024/Q674F1261

T872R1164/Q672L1185
or
T874R1129/Q674L1181

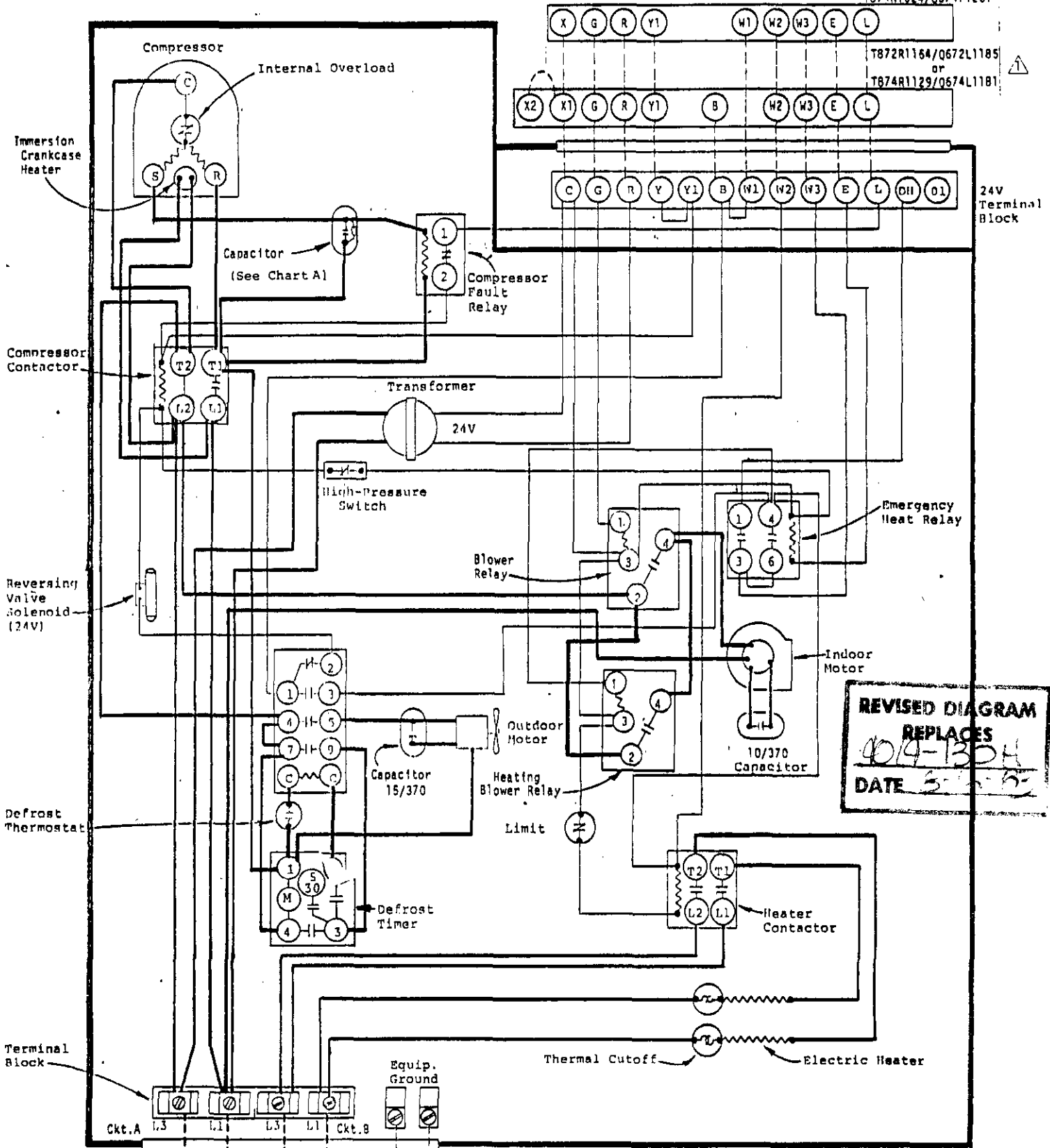

**REVISED DIAGRAM
REPLACES
4014-1304
DATE 5-2-75**

Fused Disconnect Switch

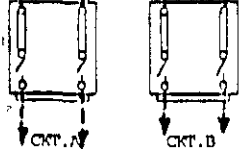

CHART A

48WH2	70/370
48WH4	40/440

USE COPPER OR ALUMINUM WIRE

	FACTORY WIRING	FIELD WIRING
Low Voltage	—————	- - - - -
High Voltage	—————	- - - - -

MODEL
48WH2, 48WH4
HEAT PUMP
10 Kw