

INSTALLATION INSTRUCTIONS

WALL MOUNTED PACKAGED AIR CONDITIONER

Models:

H42A2	H42L2
H48A2	H48L2
H60A2	H60L2

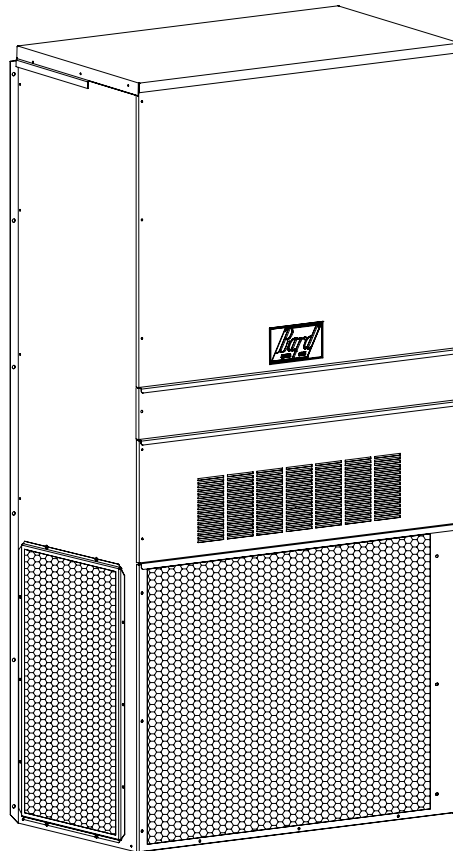

MIS-2498

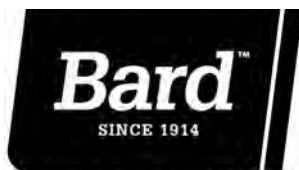

Climate Control Solutions

Bard Manufacturing Company, Inc.
Bryan, Ohio 43506

Since 1914...Moving ahead just as planned.

Manual : 2100-585
Supersedes: **NEW**
File: Volume III Tab 16
Date: 03-13-13

CONTENTS

Getting Other Information and Publications 3

Wall Mount General Information

Wall Mount Model Nomenclature 4
 Shipping Damage 4
 General 4
 Duct Work 5
 Filters 5
 Condensate Drain 5

Installation Instructions

Wall Mounting Information 6
 Mounting the Unit 6
 Clearances Required 6
 Minimum Clearances 6
 Wiring – Main Power 12
 Wiring – Low Voltage Wiring 12
 Dirty Filter Switch & Relay 12
 Economizer Fail Time Delay Relay 12

Figures

Figure 1 Unit Dimensions 7
 Figure 2 Mounting Instructions - H42, 48, 60 8
 Figure 3 Electric Heat Clearance 9
 Figure 4 Wall Mounting Instructions 10
 Figure 5 Wall Mounting Instructions 10
 Figure 6 Common Wall Mounting Installations 11
 Figure 7 Fan Blade Setting 15

Start Up

General 13
 Topping Off System Charge 13
 Safety Practices 13
 Important Installer Note 13
 High Pressure Switch 13
 Condenser Fan Operation 14
 Service Hints 14
 Sequence of Operation 14
 Compressor Control Module 14
 Adjustments 14
 Pressure Service Ports 14

Troubleshooting

Fan Blade Setting Dimensions 15
 Refrigerant Charge 15
 Removal of Fan Shroud 15

Tables

Table 1 Fan Blade Dimensions 15
 Table 2 Cooling Pressure 16
 Table 3 Electrical Specifications H**A, H**L 17
 Table 4 Recommended Airflow 18
 Table 5 Indoor Blower Performance 18
 Table 6 Electric Heat 18
 Table 7 Optional Accessories 19
 Table 8 Vent & Control Options 19

GETTING OTHER INFORMATION AND PUBLICATIONS

These publications can help you install the air conditioner or heat pump. You can usually find these at your local library or purchase them directly from the publisher. Be sure to consult current edition of each standard.

National Electrical Code ANSI/NFPA 70

Standard for the Installation ANSI/NFPA 90A
of Air Conditioning and Ventilating Systems

Standard for Warm Air ANSI/NFPA 90B
Heating and Air Conditioning Systems

Load Calculation for ACCA Manual J
Residential Winter and Summer Air Conditioning

Duct Design for Residential ACCA Manual D
Winter and Summer Air Conditioning and Equipment
Selection

FOR MORE INFORMATION, CONTACT THESE PUBLISHERS:

ACCA **Air Conditioning Contractors of America**
1712 New Hampshire Ave. N.W.
Washington, DC 20009
Telephone: (202) 483-9370
Fax: (202) 234-4721

ANSI **American National Standards Institute**
11 West Street, 13th Floor
New York, NY 10036
Telephone: (212) 642-4900
Fax: (212) 302-1286

ASHRAE **American Society of Heating, Refrigeration
and Air Conditioning Engineers, Inc.**
1791 Tullie Circle, N.E.
Atlanta, GA 30329-2305
Telephone: (404) 636-8400
Fax: (404) 321-5478

NFPA **National Fire Protection Association**
Batterymarch Park
P.O. Box 9101
Quincy, MA 02269-9901
Telephone: (800) 344-3555
Fax: (617) 984-7057

WALL MOUNT GENERAL INFORMATION

AIR CONDITIONER WALL MOUNT MODEL NOMENCLATURE

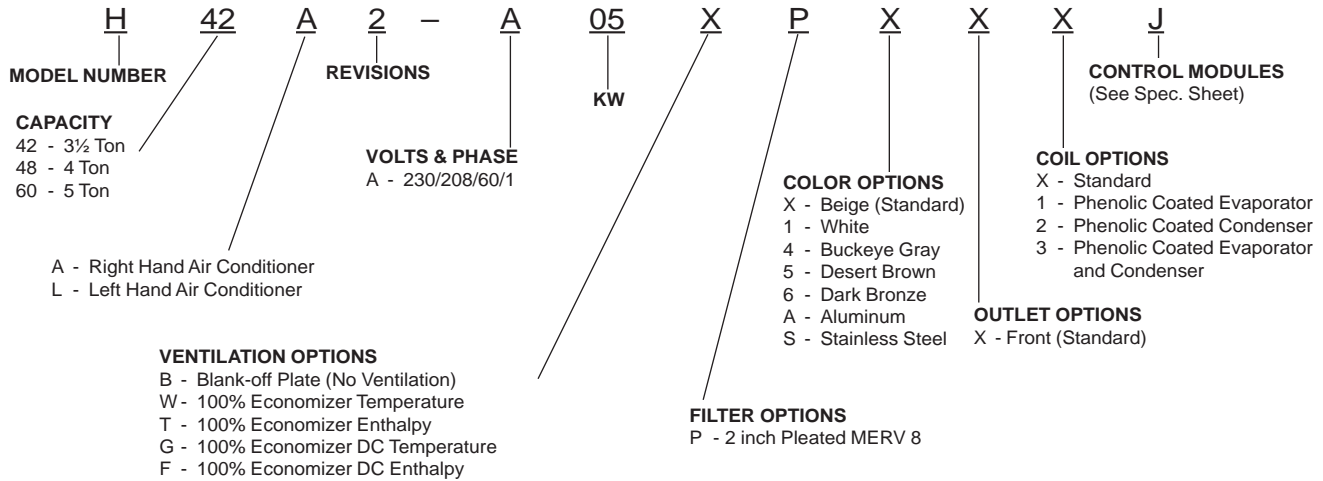

SHIPPING DAMAGE

Upon receipt of equipment, the carton should be checked for external signs of shipping damage. If damage is found, the receiving party must contact the last carrier immediately, preferably in writing, requesting inspection by the carrier’s agent.

GENERAL

The equipment covered in this manual is to be installed by trained, experienced service and installation technicians.

The refrigerant system is completely assembled and charged. All internal wiring is complete.

The unit is designed for use with or without duct work. Flanges are provided for attaching the supply and return ducts.

These instructions explain the recommended method to install the air cooled self-contained unit and the electrical wiring connections to the unit.

These instructions and any instructions packaged with any separate equipment required to make up the entire air conditioning system should be carefully read before beginning the installation. Note particularly “Starting Procedure” and any tags and/or labels attached to the equipment.

While these instructions are intended as a general recommended guide, they do not supersede any national and/or local codes in any way. Authorities having jurisdiction should be consulted before the installation is made. See Page 3 for information on codes and standards.

Size of unit for a proposed installation should be based on heat loss calculation made according to methods of Air Conditioning Contractors of America (ACCA). The air duct should be installed in accordance with the Standards of the National Fire Protection Association for the Installation of Air Conditioning and Ventilating Systems of Other Than Residence Type, NFPA No. 90A, and Residence Type Warm Air Heating and Air Conditioning Systems, NFPA No. 90B. Where local regulations are at a variance with instructions, installer should adhere to local codes.

DUCT WORK

All duct work, supply and return, must be properly sized for the design airflow requirement of the equipment. Air Conditioning Contractors of America (ACCA) is an excellent guide to proper sizing. All duct work or portions thereof not in the conditioned space should be properly insulated in order to both conserve energy and prevent condensation or moisture damage.

Refer to Table 5 for maximum static pressure available for duct design.

Design the duct work according to methods given by the Air Conditioning Contractors of America (ACCA). When duct runs through unheated spaces, it should be insulated with a minimum of one inch of insulation. Use insulation with a vapor barrier on the outside of the insulation. Flexible joints should be used to connect the duct work to the equipment in order to keep the noise transmission to a minimum.

For model series H42, H48 and H60 a 1/4 inch clearance to combustible material for the first three feet of duct attached to the outlet air frame is required. See Wall Mounting Instructions and Figures 2 and 3 for further details.

Ducts through the walls must be insulated and all joints taped or sealed to prevent air or moisture entering the wall cavity.

Some installations may not require any return air duct. A metallic return air grille is required with installations not requiring a return air duct. The spacing between louvers on the grille shall not be larger than 5/8 inch.

Any grille that meets with 5/8 inch louver criteria may be used. It is recommended that Bard Return Air Grille Kit RG5 or RFG5 be installed when no return duct is used. Contact distributor or factory for ordering information. If using a return air filter grille, filters must be of sufficient size to allow a maximum velocity of 400 fpm.

NOTE: If no return air duct is used, applicable installation codes may limit this cabinet to installation only in a single story structure.

FILTERS

A 2-inch pleated MERV 8 is standard with each unit. The filter slides into position making it easy to service. This filter can be serviced from the outside by removing the filter access panel.

CONDENSATE DRAIN

A plastic drain hose extends from the drain pan at the top of the unit down to the unit base. There are openings in the unit base for the drain hose to pass through. In the event the drain hose is connected to a drain system of some type, it must be an open or vented type system to assure proper drainage.

INSTALLATION INSTRUCTIONS

WALL MOUNTING INFORMATION

1. Two holes for the supply and return air openings must be cut through the wall as shown in Figure 2.
2. On wood frame walls, the wall construction must be strong and rigid enough to carry the weight of the unit without transmitting any unit vibration.
3. Concrete block walls must be thoroughly inspected to insure that they are capable of carrying the weight of the installed unit.

 WARNING
<p><i>Failure to provide the 1/4 inch clearance between the supply duct and a combustible surface for the first 3 feet of duct can result in fire causing damage, injury or death.</i></p>

MOUNTING THE UNIT

1. These units are secured by wall mounting brackets which secure the unit to the outside wall surface at both sides. A bottom mounting bracket, attached to skid for shipping, is provided for ease of installation, but is not required.
2. The unit itself is suitable for 0 inch clearance, but the supply air duct flange and the first 3 feet of supply air duct require a minimum of 1/4 inch clearance to combustible material for model series H42, H48 and H60. However, it is generally recommended that a 1-inch clearance is used for ease of installation and maintaining the required clearance to combustible material. See Figure 2 for details on opening sizes.
3. Locate and mark lag bolt locations and bottom mounting bracket location. See Figure 2.
4. Mount bottom mounting bracket.
5. Hook top rain flashing, attached to front - right of supply flange for shipping, under back bend of top.
6. Position unit in opening and secure with 5/16 lag bolts; use 7/8 inch diameter flat washers on the lag bolts.
7. Secure rain flashing to wall and caulk across entire length of top. See Figure 2.
8. For additional mounting rigidity, the return air and supply air frames or collars can be drilled and screwed or welded to the structural wall itself (depending upon wall construction). Be sure to observe required clearance if combustible wall.
9. On side-by-side installations, maintain a minimum of 20 inches clearance on right side to allow access to control panel and heat strips, and to allow proper airflow to the outdoor coil. Additional clearance may be required to meet local or national codes.

Clearances Required for Service Access and Adequate Condenser Airflow

MODELS	LEFT SIDE	RIGHT SIDE
H42A, H48A, H60A	20"	20"
H42L, H48L, H60L	20"	20"

NOTE: For side by side installation of two (2) H**A models there must be 20" between units. This can be reduced to 15" by using a H**L model (left side compressor and controls) for the left unit and HA (right side compressor and controls) for right unit.

Minimum Clearances Required to Combustible Materials

MODELS	SUPPLY AIR DUCT FIRST THREE FEET	CABINET
H42A, L / H48A, L H60A, L	1/4"	0"

FIGURE 1

Dimensions of Basic Unit for Architectural & Installation Requirements (Nominal)

MODEL	WIDTH (W)	DEPTH (D)	HEIGHT (H)	SUPPLY		RETURN		E	F	G	I	J	K	L	M	N	O	P	Q	R	S1	S2	T
				A	B	C	B																
H42A H42L H48A H48L H60A H60L	42.075	22.432	84.875	9.88	29.88	15.88	29.88	43.88	19.10	31.66	30.00	32.68	26.94	34.69	32.43	3.37	43.00	23.88	10.00	1.44	16.00	16.00	1.88

All dimensions are in inches. Dimensional drawings are not to scale.

HA
RIGHT
UNIT**

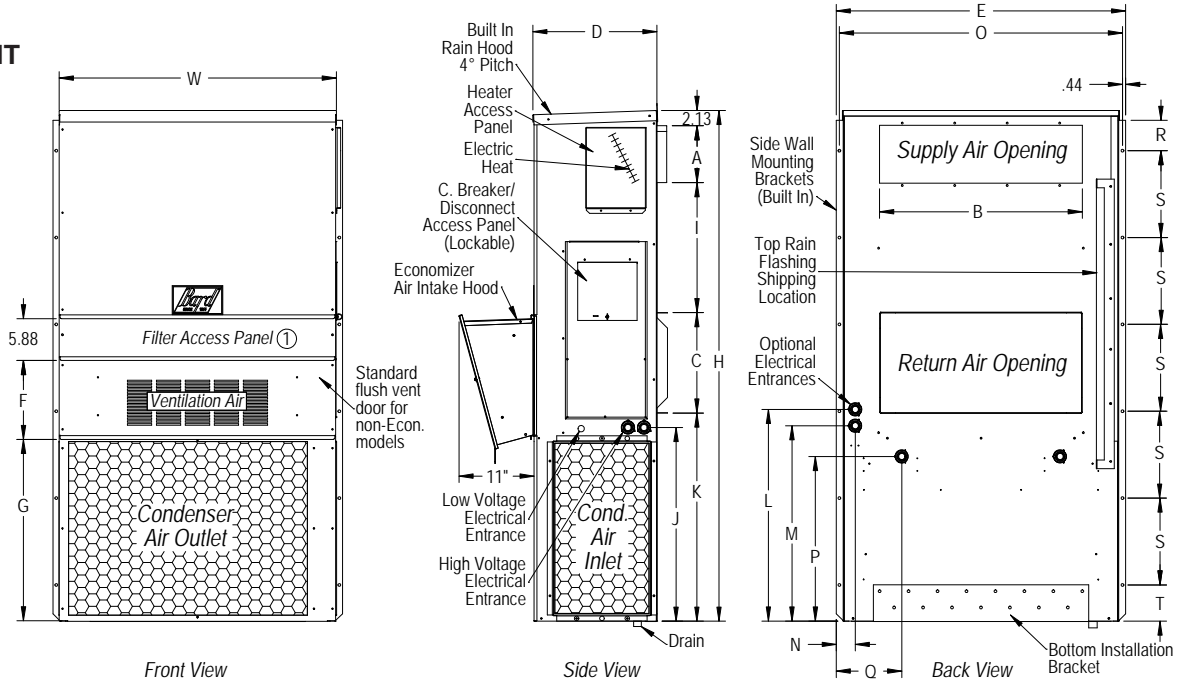

MIS-3210

NOTE 1: Not used when ECONWMT Economizer installed. Filter access is through the ECONWMT hood.

HL
LEFT
UNIT**

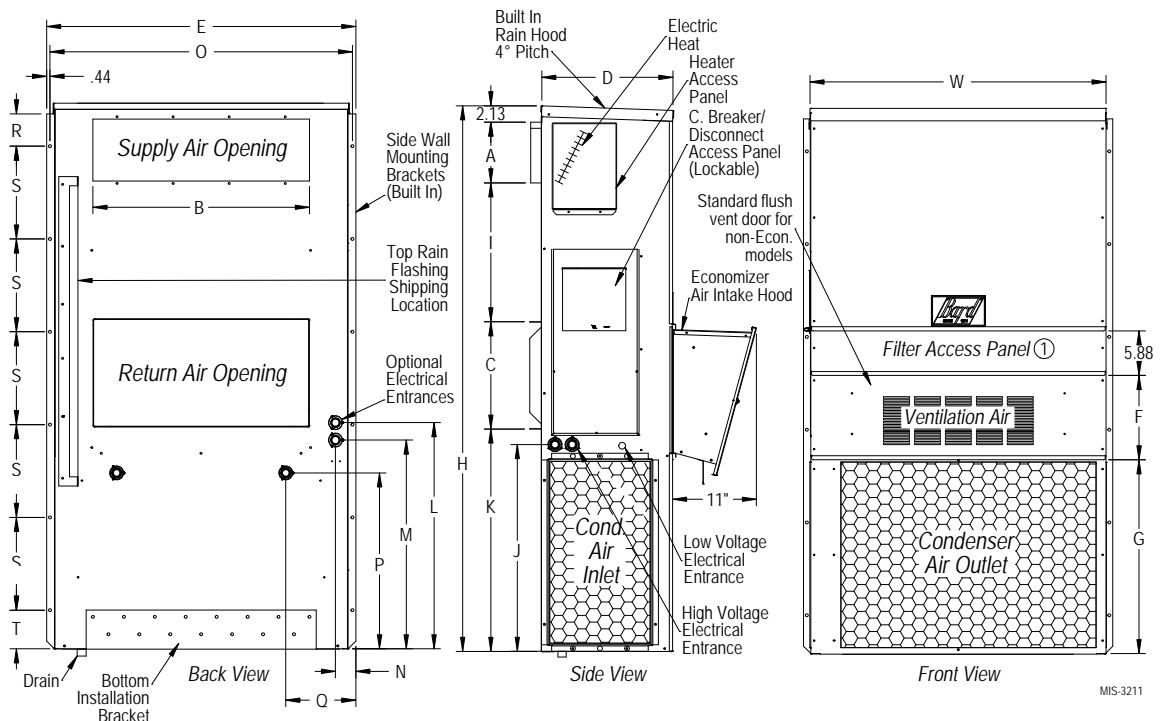

MIS-3211

NOTE 1: Not used when ECONWMT Economizer installed. Filter access is through the ECONWMT hood.

FIGURE 3
ELECTRIC HEAT CLEARANCE
H42A2, H42L2, H48A2, H48L2, H60A2, H60L2

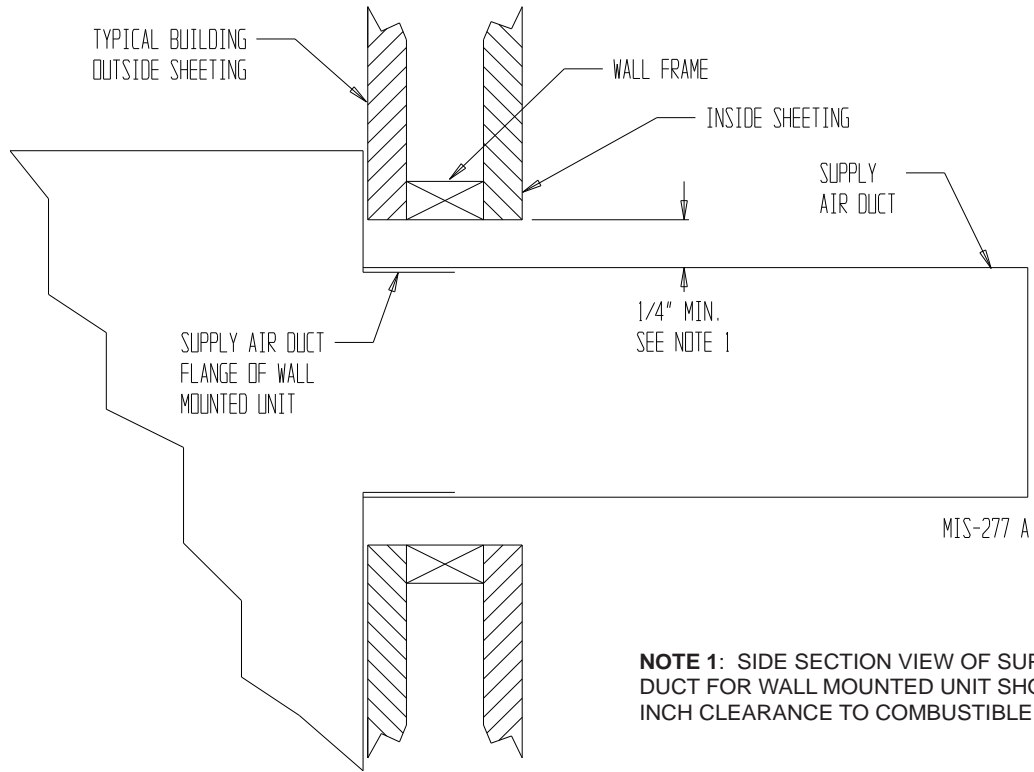

NOTE 1: SIDE SECTION VIEW OF SUPPLY AIR DUCT FOR WALL MOUNTED UNIT SHOWING 1/4 INCH CLEARANCE TO COMBUSTIBLE SURFACES.

WARNING

A *minimum* of 1/4 inch clearance must be maintained between the supply air duct and combustible materials. This is required for the first 3 feet of ducting.

It is important to insure that the 1/4 inch minimum spacing is maintained at all points.

Failure to do this could result in overheating the combustible material and may result in a fire causing damage, injury or death.

FIGURE 4 WALL MOUNTING INSTRUCTIONS

SEE FIGURE 3 – MOUNTING INSTRUCTIONS

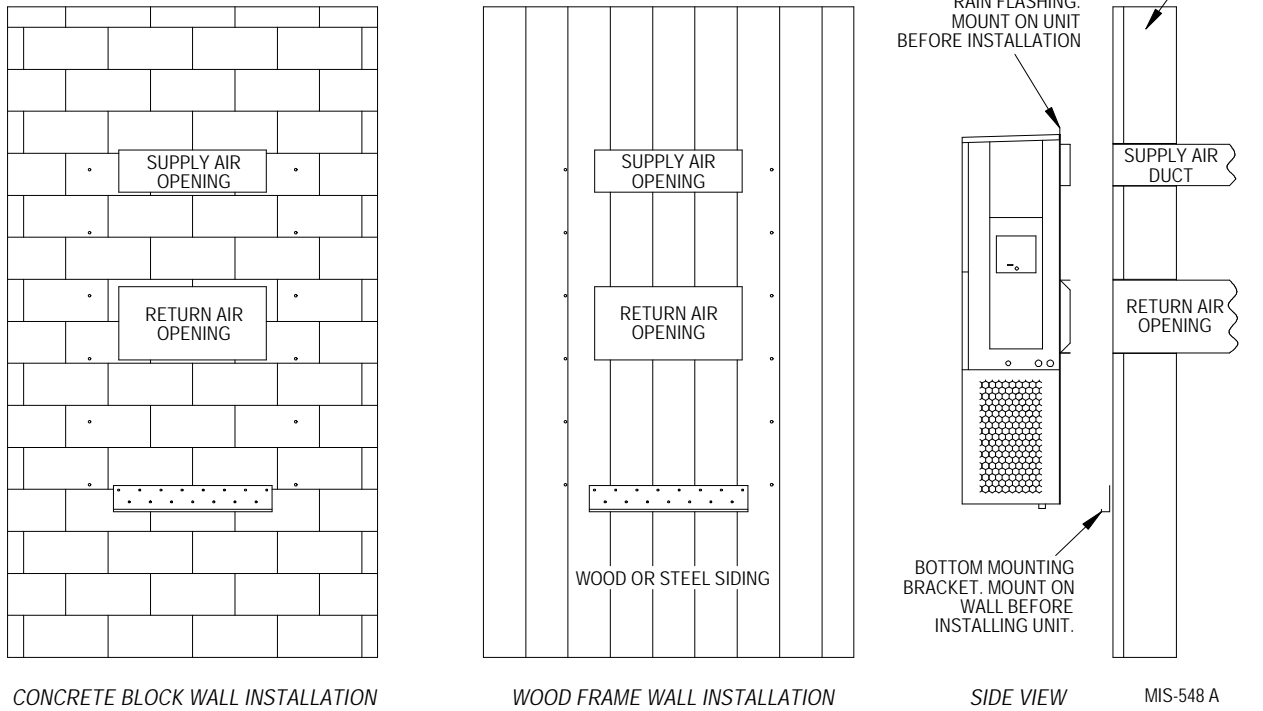

CONCRETE BLOCK WALL INSTALLATION

WOOD FRAME WALL INSTALLATION

SIDE VIEW

MIS-548 A

FIGURE 5 WALL MOUNTING INSTRUCTIONS

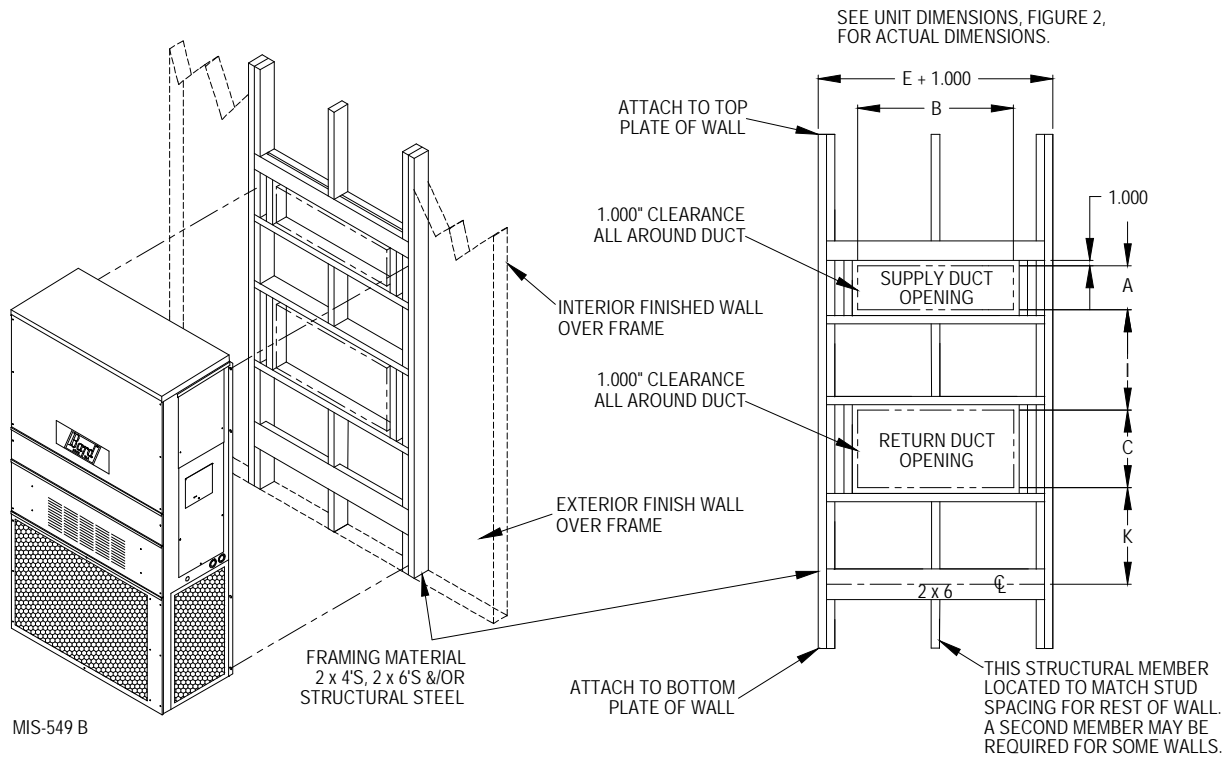

MIS-549 B

**FIGURE 6
COMMON WALL MOUNTING INSTALLATIONS**

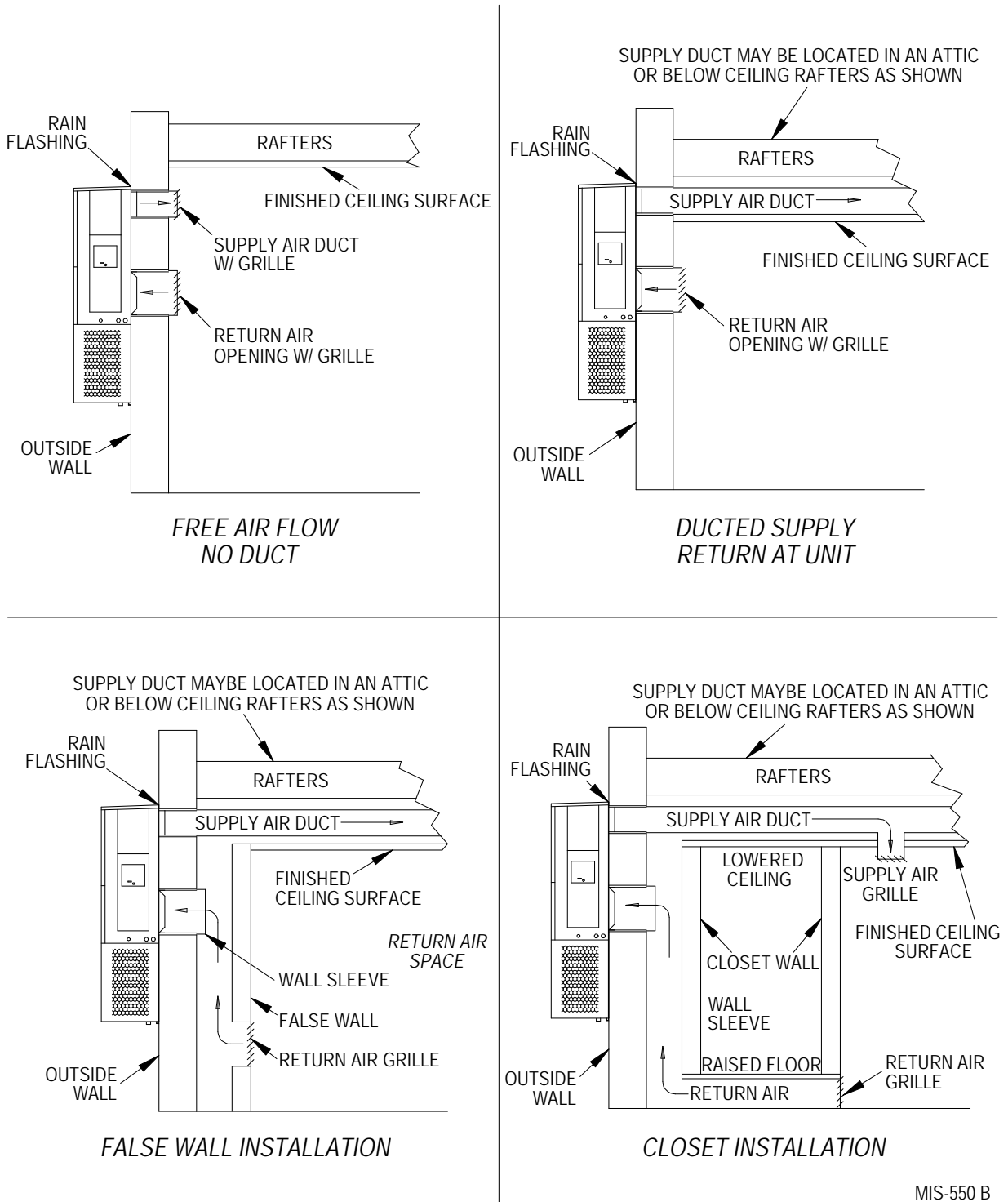

MIS-550 B

WIRING – MAIN POWER

Refer to the unit rating plate for wire sizing information and maximum fuse or “HACR” type circuit breaker size. Each outdoor unit is marked with a “Minimum Circuit Ampacity”. This means that the field wiring used must be sized to carry that amount of current.

Depending on the installed KW of electric heat, there may be two field power circuits required. If this is the case, the unit serial plate will so indicate. All models are suitable only for connection with copper wire. Each unit and/or wiring diagram will be marked “Use Copper Conductors Only”. These instructions **must be** adhered to. Refer to the National Electrical Code (NEC) for complete current carrying capacity data on the various insulation grades of wiring material. All wiring must conform to NEC and all local codes.

The electrical data lists fuse and wire sizes (75° C copper) for all models including the most commonly used heater sizes. Also shown are the number of field power circuits required for the various models with heaters.

The unit rating plate lists a “Maximum Time Delay Relay Fuse” or “HACR” type circuit breaker that is to be used with the equipment. The correct size must be used for proper circuit protection and also to assure that there will be no nuisance tripping due to the momentary high starting current of the compressor motor.

The disconnect access door on this unit may be locked to prevent unauthorized access to the disconnect. To convert for the locking capability, bend the tab located in the bottom left-hand corner of the disconnect opening under the disconnect access panel straight out. This tab will now line up with the slot in the door. When shut, a padlock may be placed through the hole in the tab preventing entry.

See “Start Up” section for important information on three phase scroll compressor start ups.

See Tables 3 & 4 for Electrical Specifications.

Low Voltage Connection

These units use a 24-volt AC low voltage circuit. The “R” terminal is the *hot* terminal and the “C” terminal is *grounded*.

“G” terminal is the *fan input*.

“Y” terminal is the *compressor input for cooling*
1-Stage units only

“W1” terminal is the *1st stage electric heat*.

“W2” terminal is the *2nd stage heat* (if equipped).

“E”, “F”, “Y2” & “A” Used with ECONWMT Economizer.

“1” NO (normally open) lockout alarm.

“2” NC (normally closed) lockout alarm.

“3” COM lockout alarm.

“4” & “5” dirty filter alarm NC (normally closed).

“6” Used with MD4000 only; do not use for anything else!

“Y1” & “7” Used with ECONWMT Economizer; do not use for anything else!

“8” & “9” ECON Fail Alarm.

WIRING – LOW VOLTAGE WIRING

230/208V, 1 phase and 3 phase equipment dual primary voltage transformers. All equipment leaves the factory wired on 240V tap. For 208V operation, reconnect from 240V to 208V tap. The acceptable operating voltage range for the 240 and 208V taps are:

TAP	RANGE
240	253 – 216
208	220 – 187

NOTE: *The voltage should be measured at the field power connection point in the unit and while the unit is operating at full load (maximum amperage operating condition).*

For H model units with T or W vent option economizers, refer to the MV4000 Series Lead/Lag Controller manual 2100-571 for low voltage connections diagrams.

Factory installed T and W vent option are wired per Figure 7 of 2100-571. T and W vent option economizers **CAN NOT** be used with MD4000 Lead/Lag Controllers.

For H model units with F or G vent option economizers, refer to the MD 4000 Series Lead/Lag Controller manual 2100-574 for low voltage connections diagrams. F and G vent option economizers **MUST** be used with the MD4000 Lead/Lag Controller. No other Lead/Lag Controller or thermostat is compatible with this economizer. Factory installed F and G vent option economizers are wired per Figure 2 of 2100-574.

DIRTY FILTER SWITCH & RELAY

These units include a dirty filter switch and relay. The alarm output of relay is normally closed, open on alarm and is connected to terminals 4 and 5 of the unit low voltage terminal block.

ECONOMIZER FAIL TIME DELAY RELAY

NOTE: *Applies only to units with economizers.*

These units employ a time delay relay used in conjunction with the 100% Economizers to provide an economizer fail alarm. The alarm output is connected to terminals 8 and 9 of the low voltage terminal block. The time delay should be set to no less than 3 minutes to ensure no nuisance alarms.

TIMER TO BE SET HERE

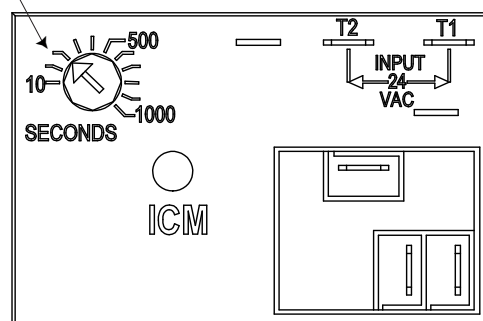

MIS-3054

THESE UNITS REQUIRE R-410A REFRIGERANT AND POLYOL ESTER OIL.

GENERAL:

1. Use separate service equipment to avoid cross contamination of oil and refrigerants.
2. Use recovery equipment rated for R-410A refrigerant.
3. Use manifold gauges rated for R-410A (800 psi/250 psi low).
4. R-410A is a binary blend of HFC-32 and HFC-125.
5. R-410A is nearly azeotropic - similar to R-22 and R-12. Although nearly azeotropic, charge with liquid refrigerant.
6. R-410A operates at 40-70% higher pressure than R-22, and systems designed for R-22 cannot withstand this higher pressure.
7. R-410A has an ozone depletion potential of zero, but must be reclaimed due to its global warming potential.
8. R-410A compressors use Polyol Ester oil.
9. Polyol Ester oil is hygroscopic; it will rapidly absorb moisture and strongly hold this moisture in the oil.
10. A liquid line dryer must be used - even a deep vacuum will not separate moisture from the oil.
11. Limit atmospheric exposure to 15 minutes.
12. If compressor removal is necessary, always plug compressor immediately after removal. Purge with small amount of nitrogen when inserting plugs.

TOPPING OFF SYSTEM CHARGE

If a leak has occurred in the system, Bard Manufacturing recommends reclaiming, evacuating (see criteria above), and charging to the nameplate charge. If done correctly, topping off the system charge can be done without problems.

With R-410A, there are no significant changes in the refrigerant composition during multiple leaks and recharges. R-410A refrigerant is close to being an azeotropic blend (it behaves like a pure compound or single component refrigerant). The remaining refrigerant charge, in the system, may be used after leaks have occurred and then “top-off” the charge by utilizing the pressure charts on the inner control panel cover as a guideline.

REMEMBER: When adding R-410A refrigerant, it must come out of the charging cylinder/tank as a liquid to avoid any fractionation, and to insure optimal system performance. Refer to instructions for the cylinder that is being utilized for proper method of liquid extraction.



WARNING

Failure to conform to these practices could lead to damage, injury or death.

SAFETY PRACTICES:

1. Never mix R-410A with other refrigerants.
2. Use gloves and safety glasses, Polyol Ester oils can be irritating to the skin, and liquid refrigerant will freeze the skin.
3. Never use air and R-410A to leak check; the mixture may become flammable.
4. Do not inhale R-410A – the vapor attacks the nervous system, creating dizziness, loss of coordination and slurred speech. Cardiac irregularities, unconsciousness and ultimate death can result from breathing this concentration.
5. Do not burn R-410A. This decomposition produces hazardous vapors. Evacuate the area if exposed.
6. Use only cylinders rated DOT4BA/4BW 400.
7. Never fill cylinders over 80% of total capacity.
8. Store cylinders in a cool area, out of direct sunlight.
9. Never heat cylinders above 125°F.
10. Never trap liquid R-410A in manifold sets, gauge lines or cylinders. R-410A expands significantly at warmer temperatures. Once a cylinder or line is full of liquid, any further rise in temperature will cause it to burst.

IMPORTANT INSTALLER NOTE

For improved start up performance wash the indoor coil with a dish washing detergent.

HIGH PRESSURE SWITCH

All H**A/H**L wall mounted air conditioner series models are supplied with a remote reset for the high and low pressure switch. If tripped, this pressure switch may be reset by turning the thermostat off then back on again.

START UP (Continued)

CONDENSER FAN OPERATION

Applies to H42, H48 and H60 models only. **NOTE:** *Certain models may be equipped with a Low Ambient Control (LAC), and if so equipped the condenser fan motor will have delay start until system refrigerant operating pressure builds up. After starting, the fan motor may or may not cycle depending upon ambient conditions. This is normal operation.* The condenser fan motor on 230/208 volt, one and three phase, 60 HZ units is a two-speed motor that comes factory wired on high speed for peak performance. If ambient conditions permit, it can be reconnected to low speed (red wire) for lower sound level. See wiring diagram.

SERVICE HINTS

1. Caution owner/operator to maintain clean air filters at all times. Also, not to needlessly close off supply and return air registers. This reduces airflow through the system, which shortens equipment service life as well as increasing operating costs.
2. Check all power fuses or circuit breakers to be sure they are the correct rating.
3. Periodic cleaning of the outdoor coil to permit full and unrestricted airflow circulation is essential.

SEQUENCE OF OPERATION

COOLING – Circuit R-Y makes at thermostat pulling in compressor contactor, starting the compressor and outdoor motor. (See Note under Condenser Fan Operation if equipped with Low Ambient Control.) The G (indoor motor) circuit is automatically completed on any call for cooling operation or can be energized by manual fan switch on subbase for constant air circulation. On a call for heating, circuit R-W1 make at the thermostat pulling in heat contact for the strip heat and blower operation. On a call for second stage heat, R-W2 makes bringing on second heat contactor, if so equipped.

COMPRESSOR CONTROL MODULE

The compressor control module is standard on all models covered by this manual. The compressor control module is an anti-short cycle/lockout timer with high and low pressure switch monitoring and alarm relay output.

Adjustable Delay On Make And Break Timer

On initial power up or anytime power is interrupted to the unit, the *delay on make* period begins, which will be 2 minutes plus 10% of the *delay on break* setting. When the delay on make is complete and the high pressure switch and low pressure switch is closed, the compressor contactor is energized. Upon shutdown, the delay on break timer starts and prevents restart until the delay on break and delay on make periods have expired.

During routine operation of the unit with no power interruptions, the compressor will operate on demand with no delay.

High Pressure Switch and Lockout Sequence

If the high pressure switch opens, the compressor contactor will de-energize immediately. The lockout timer will go into a *soft lockout* and stay in soft lockout until the high pressure switch closes and the delay on break time has expired. If the high pressure switch opens again in this same operating cycle, the unit will go into *manual lockout* condition and the alarm relay circuit will energize. Recycling the wall thermostat resets the manual lockout.

Low Pressure Switch, Bypass & Lockout Sequence

If the low pressure switch opens for more than 120 seconds, the compressor contactor will de-energize and go into a soft lockout. Regardless the state of the low pressure switch, the contactor will reenergize after the delay on make time delay has expired. If the low pressure switch remains open, or opens again for longer than 120 seconds, the unit will go into manual lockout condition and the alarm relay circuit will energize. Recycling the wall thermostat resets the manual lockout.

Alarm Relay Output

Alarm terminal is output connection for applications where alarm relay is employed. This terminal is powered whenever the compressor is locked out due to HPC or LPC sequences as described.

NOTE: Both high and low pressure switch controls are inherently automatic reset devices. The high pressure switch and low pressure switch cut out and cut in settings are fixed by specific air conditioner unit model. The lockout features, both soft and manual, are a function of the Compressor Control Module.

ADJUSTMENTS

Adjustable Delay on Make and Delay on Break Timer

The potentiometer is used to select Delay on Break time from 30 seconds to 5 minutes. Delay on Make (DOM) timing on power-up and after power interruptions is equal to 2 minutes plus 10% of Delay on Break (DOB) setting:

0.5 minute (30 seconds)	DOB = 123 second	DOM
1.0 minute (60 seconds)	DOB = 126 second	DOM
2.0 minute (120 seconds)	DOB = 132 second	DOM
3.0 minute (180 seconds)	DOB = 138 second	DOM
4.0 minute (240 seconds)	DOB = 144 second	DOM
5.0 minute (300 seconds)	DOB = 150 second	DOM

During routine operation of the unit with no power interruptions the compressor will operate on demand with no delay.

Typical Settings for Dual Unit Installation:

Unit 1: DOB set at 2 minutes, and DOM is 132 seconds
Unit 2: DOB set at 4 minutes, and DOM is 144 seconds

PRESSURE SERVICE PORTS

High & low pressure service ports are installed on all units so that the system operating pressures can be observed. A pressure table can be found later in the manual covering all models. It is imperative to match the correct pressure table to the unit by model number. See Table 2.

FAN BLADE SETTING DIMENSIONS

Shown in Figure 7 is the correct fan blade setting for proper air delivery across the outdoor coil. Refer to Table 1 for unit specific dimension.

Any service work requiring removal or adjustment in the fan and/or motor area will require that the dimensions below be checked and blade adjusted in or out on the motor shaft accordingly.

**FIGURE 7
FAN BLADE SETTING**

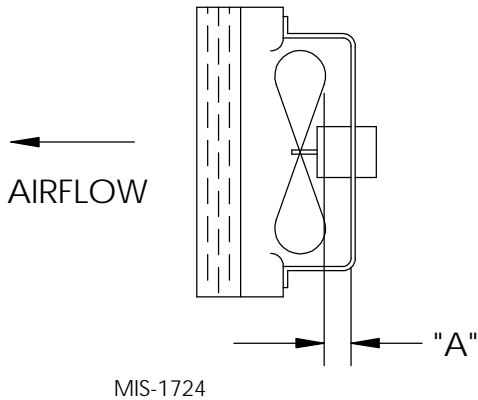

**TABLE 1
FAN BLADE DIMENSION**

Model	Dimension A
H42A2 / H42L2 H48A2 / H48L2 H60A2 / H60L2	1.75"

R-410A

REFRIGERANT CHARGE

This unit was charged at the factory with the quantity of refrigerant listed on the serial plate. AHRI capacity and efficiency ratings were determined by testing with this refrigerant charge quantity.

The following pressure tables show nominal pressures for the units. Since many installation specific situations can affect the pressure readings, this information should only be used by certified technicians as a guide for evaluating proper system performance. They shall not be used to adjust charge. If charge is in doubt, reclaim, evacuate and recharge the unit to the serial plate charge.

REMOVAL OF FAN SHROUD

1. Disconnect all power to the unit.
2. Remove the screws holding both grilles, one on each side of unit, and remove grilles.
3. Remove screws holding fan shroud to condenser and bottom. Nine (9) screws.
4. Unwire condenser fan motor.
5. Slide complete motor, fan blade, and shroud assembly out the left side of the unit.
6. Service motor/fan as needed.
7. Reverse steps to reinstall.

**TABLE 2
COOLING PRESSURE TABLE**

Air Temperature Entering Outdoor Coil °F

Model	Return Air Temp (DB/WB)	Pressure	75	80	85	90	95	100	105	110	115	120
H42A/L	75° DB 62° WB	Low Side High Side	123 320	124 342	126 367	128 391	130 416	132 443	134 469	136 496	137 526	139 554
	80° DB 67° WB	Low Side High Side	132 328	133 351	135 376	137 401	139 427	141 454	143 481	145 509	147 539	149 568
	85° DB 72° WB	Low Side High Side	137 339	138 363	140 389	142 415	144 442	146 470	148 498	150 527	152 558	154 588
H48A/L	75° DB 62° WB	Low Side High Side	117 355	119 378	121 403	123 427	125 454	127 482	129 510	131 539	133 570	135 603
	80° DB 67° WB	Low Side High Side	125 364	127 388	129 413	132 438	134 466	136 494	138 523	140 553	142 585	144 618
	85° DB 72° WB	Low Side High Side	129 377	131 402	134 427	137 453	139 482	141 511	143 541	145 572	147 605	149 640
H60A/L	75° DB 62° WB	Low Side High Side	122 346	124 371	126 396	128 421	130 447	131 473	133 499	135 526	137 553	138 580
	80° DB 67° WB	Low Side High Side	131 355	133 380	135 406	137 432	139 458	140 485	142 512	144 539	146 567	148 595
	85° DB 72° WB	Low Side High Side	136 367	138 393	140 420	142 447	144 474	145 502	147 530	149 558	151 587	153 616

Low side pressure ± 4 PSIG
High side pressure ± 10 PSIG

Tables are based upon rated CFM (airflow) across the evaporator coil. If there is any doubt as to correct operating charge being in the system, the charge should be removed, system evacuated and recharged to serial plate charge weight.

NOTE: Pressure table based on high speed condenser fan operation. If condensing pressures appear elevated check condenser fan wiring. See "Condenser Fan Operation".

TABLE 3

Electrical Specifications 1-Stage Compressor Models														
MODEL	Rated Volts & Phase	No. Field Power Circuits	Single Circuit				Dual Circuit							
			③ Minimum Circuit Ampacity	① Maximum External Fuse or Ckt. Brkr.	② Field Power Wire Size	② Ground Wire	③ Minimum Circuit Ampacity		① Maximum External Fuse or Ckt. Breaker		② Field Power Wire Size		② Ground Wire Size	
							Ckt. A	Ckt. B	Ckt. A	Ckt. B	Ckt. A	Ckt. B	Ckt. A	Ckt. B
H42A2-A00, A0Z H42L2 A05 A10 A15	230/208-1	1 1 1 1 or 2	32 32 58 84	50 50 60 90	8 8 6 4	10 10 10 8								
H48A2-A00, A0Z H48L2 A05 A10 A15	230/208-1	1 1 1 1 or 2	39 39 58 84	50 50 60 90	8 8 6 4	10 10 10 8								
H60A2-A00, A0Z H60L2 A05 A10 A15	230/208-1	1 1 1 1 or 2	42 42 60 86	60 60 60 90	8 8 6 3	10 10 10 8								

① Maximum size of the time delay fuse or HACR type circuit breaker for protection of field wiring conductors.

② Based on 75C copper wire. All wiring must conform to the National Electrical Code and all local codes.

③ These "Minimum Circuit Ampacity" values are to be used for sizing the field power conductors. Refer to the National Electrical code (latest version), Article 310 for power conductor sizing.

Caution: When more than one field power circuit is run through one conduit, the conductors must be derated. Pay special attention to note 8 of Table 310 regarding Ampacity Adjustment Factors when more than three (3) current carrying conductors are in a raceway.

IMPORTANT: While this electrical data is presented as a guide, it is important to electrically connect properly sized fuses and conductor wires in accordance with the National Electrical Code and all local codes.

**TABLE 4
RECOMMENDED AIRFLOW**

Model	Rated CFM *	Rated ESP *	Recommended Airflow Range	Factory Speed Connection
H42A, H42L	1400	.45	1600 - 1150	High
H48A, H48L	1550	.30	1750 - 1285	High
H60A, H60L	1700	.40	1950 - 1375	High

* Rated CFM and ESP on high speed tap.

**TABLE 5
INDOOR BLOWER PERFORMANCE**

Speed	H42/48				H60			
	High		Low		High		Low	
ESP (Inch H2O)	Dry Coil	Wet Coil	Dry Coil	Wet Coil	Dry Coil	Wet Coil	Dry Coil	Wet Coil
0.0	1850	1800	1605	1555	2080	2015	1505	1460
0.1	1775	1725	1545	1500	2020	1960	1450	1405
0.2	1685	1640	1460	1415	1925	1865	1395	1355
0.3	1590	1550	1390	1345	1870	1815	1340	1300
0.4	1495	1460	1310	1270	1755	1705	1225	1185
0.5	1400	1365	1225	1185	1660	1610	1125	1085

**TABLE 6
ELECTRIC HEAT**

Models	240V-1		208V-1	
	KW	Amps	Amps	BTUH
5	20.8	17065	18.1	12800
10	41.6	34130	36.2	25600
15	62.5	51250	54.0	38400

**TABLE 7
OPTIONAL ACCESSORIES**

		H42A2-A	H48A2-A	H60A2-A
HEATER KITS	EHWA05-A05	X	X	
	EHWA05-A10	X	X	X
	EHWA05-A15	X	X	X
CIRCUIT BREAKER (WMCB) & PULL DISCONNECT (WMPD)	WMCB-08A	X	X	

**TABLE 8
VENT & CONTROL OPTIONS**

Factory Installed Option Number	Field Installed Part Number		H42, H48, H60
N/A	CMC-15	Start Kit (230V 1-Phase)	
B	BOP-5	Blank Off Plate	X
T	ECONWMT-T5*	100% Economizer Temperature	X
W	ECONWMT-E5*	100% Economizer Enthalpy	X
F	N/A	100% Economizer DC Temperature	X
G	N/A	100% Economizer DC Enthalpy	X