INSTALLATION INSTRUCTIONS

HOT GAS BYPASS SYSTEM DESIGN MANUAL

Models:
WA484H
WA602H
WA701HB
WA701HC
WA702HA

NOTE: Electrical data presented in this manual supersedes any other data for the above listed models.



Climate Control Solutions

Bard Manufacturing Company, Inc.
Bryan, Ohio 43506
Since 1914...Moving ahead just as planned.

Manual : 2100-424A
Supersedes: 2100-424
File: Volume III Tab 16
Date: 04-19-04

CONTENTS

Electrical Data	1
General	2
System Capacity Control	2
Bypass to Evaporator Inlet with Distributor	3
Externally Equalized Bypass Valves	3
Head Pressure Control	4
ORI Valve Operation	4
ORD Valve Operation	5
Adjustable ORI / ORD System Operation	5
Refrigerant Charge	6
Refrigerant Piping and Flow Diagram	6
Troubleshooting Guide	6
Wiring	8
Typical Control Circuit Wiring	8
Wiring – Main Power	8

Figures

Figure 1	Hot Gas Bypass Valve	2
Figure 2	Capacity Control Piping	3
Figure 3	Head Pressure Control Valve	4
Figure 4	ORD Valve	5
Figure 5	ORI / ORD System	5
Figure 6	Troubleshooting Guide	7
Figure 7	Low Voltage Wiring	9
Figure 8	Hot Gas Bypass Typical Piping	10
Figure 9	Hot Gas Bypass Compressor Burnout Procedure	11

Tables

Table 1	Electrical Specifications	1
---------	---------------------------------	---

**TABLE 1
ELECTRICAL SPECIFICATIONS**

Models	Rated	No. of Power Circuits	Single Circuit				Dual Circuit											
			Minimum Circuit Ampacity	Maximum External Fuse or Circuit Breaker	Field Wire Size	Ground Wire Size	①				②				②			
							Minimum Circuit Ampacity	Maximum External Fuse or Circuit Breaker	Minimum Circuit Ampacity	Maximum External Fuse or Circuit Breaker	Minimum Circuit Ampacity	Maximum External Fuse or Circuit Breaker	Field Wire Size	Ground Wire Size				
Minimum Circuit Ampacity	Maximum External Fuse or Circuit Breaker	Field Wire Size	Ground Wire Size	CKT A	CKT B	CKT C	CKT A	CKT B	CKT C	CKT A	CKT B	CKT C	CKT A	CKT B	CKT C			
WA484HA10	230/208-1	1 or 2	87	100	3	8	39	52	N/A	60	60	N/A	8	8	N/A	10	10	N/A
WA484HA20	230/208-1	1 or 3	140	150	1/0	6	39	52	52	60	60	60	8	8	6	10	10	10
WA484HB09	230/208-3	1	51	60	6	10	N/A	N/A	N/A	N/A	N/A	N/A	N/A	N/A	N/A	N/A	N/A	N/A
WA484HB18	230/208-3	2	N/A	N/A	N/A	N/A	51	28	N/A	60	30	N/A	60	10	N/A	10	10	N/A
WA484HC0Z	460-3-60	1	12	15	14	14	N/A	N/A	N/A	N/A	N/A	N/A	N/A	N/A	N/A	N/A	N/A	N/A
WA484HC15	460-3-60	1	35	35	8	10	N/A	N/A	N/A	N/A	N/A	N/A	N/A	N/A	N/A	N/A	N/A	N/A
WA484HF14	415-3-50	1	33	35	8	10	N/A	N/A	N/A	N/A	N/A	N/A	N/A	N/A	N/A	N/A	N/A	N/A
WA602HA10	230/208-1	1 or 2	94	110	3	6	42	52	N/A	60	60	N/A	8	8	N/A	10	10	N/A
WA602HA20	230/208-1	1 or 3	147	150	1/0	6	42	52	52	60	60	60	8	8	6	10	10	10
WA602HB09	230/208-3	1	57	70	6	8	N/A	N/A	N/A	N/A	N/A	N/A	N/A	N/A	N/A	N/A	N/A	N/A
WA602HB18	230/208-3	2	N/A	N/A	N/A	N/A	57	28	N/A	60	30	N/A	6	6	N/A	10	10	N/A
WA602HC0Z	460-3-60	1	15	20	12	12	N/A	N/A	N/A	N/A	N/A	N/A	N/A	N/A	N/A	N/A	N/A	N/A
WA602HC09	460-3-60	1	28	30	10	10	N/A	N/A	N/A	N/A	N/A	N/A	N/A	N/A	N/A	N/A	N/A	N/A
WA602HC15	460-3-60	1	37	40	8	10	N/A	N/A	N/A	N/A	N/A	N/A	N/A	N/A	N/A	N/A	N/A	N/A
WA602HF14	415-3-50	1	35	40	8	10	N/A	N/A	N/A	N/A	N/A	N/A	N/A	N/A	N/A	N/A	N/A	N/A
WA702HA10	230/208-1	1 or 2	98	110	3	6	46	52	N/A	60	60	N/A	8	8	N/A	10	10	N/A
WA702HA15	230/208-1	1 or 3	124	140	1/0	6	46	52	26	60	60	30	8	8	10	10	10	10
WA701HB09	230/208-3	1	59	60	6	8	N/A	N/A	N/A	N/A	N/A	N/A	N/A	N/A	N/A	N/A	N/A	N/A
WA701HB18	230/208-3	2	N/A	N/A	N/A	N/A	59	28	N/A	60	30	N/A	6	6	N/A	10	10	N/A
WA701HC0Z	460-3-60	1	18	25	12	12	N/A	N/A	N/A	N/A	N/A	N/A	N/A	N/A	N/A	N/A	N/A	N/A
WA701HC09	460-3-60	1	31	35	10	10	N/A	N/A	N/A	N/A	N/A	N/A	N/A	N/A	N/A	N/A	N/A	N/A
WA701HC18	460-3-60	1	40	40	8	10	N/A	N/A	N/A	N/A	N/A	N/A	N/A	N/A	N/A	N/A	N/A	N/A

① Maximum size of the time delay fuse or HACR type circuit breaker for protection of field wiring conductors

② Based on 75° copper wire

GENERAL

The Hot Gas Bypass System design consists of two important modifications to the standard air conditioning unit: 1. system capacity control; and 2. head pressure control. Each of these sets of controls perform a specific function but both are necessary and dependent upon one another in the overall operation of the system.

The system is designed for outdoor operating temperature range of -20°F to 115°F. Both the head pressure control and the system capacity control are accomplished in the refrigerant cycle design and are independent of the electrical circuit. Therefore, it can be applied to all voltage, phase, KW and other variations of basic system design package air conditioners. Cycling the outdoor fan to control the head pressure is not recommended for use in conjunction with this system.

SYSTEM CAPACITY CONTROL

The hot gas bypass valve monitors the outlet pressure of the evaporator and will begin to modulate open as the

load on the unit decreases to the point where the evaporator temperature is at the setpoint of the bypass valve. The bypass valves are factory adjusted to a setting of 61 psig (35°F evaporator temperature). This means that the compressor can be operated continuously and the minimum evaporator temperature will be maintained at 35°F regardless of indoor or outdoor load conditions. Should a high evaporator temperature be desired it can be increased by turning the adjusting screw in a CW direction.

The hot gas bypass valve (also called Discharge Bypass Valve, or DBV) responds to changes in downstream pressure (suction pressure) from the evaporator.

When the evaporating pressure is above the valve setting the valve remains closed. As the suction pressure drops below the valve setting the valve responds and begins to open. As with all modulating type valves, the amount of opening is proportional to the change in the variable being controlled - in this case the suction pressure. As the suction pressure continues to drop, the valve continues to open farther until the limit of the valve stroke is reached. See Figure 1.

**FIGURE 1
HOT GAS BYPASS VALVE**

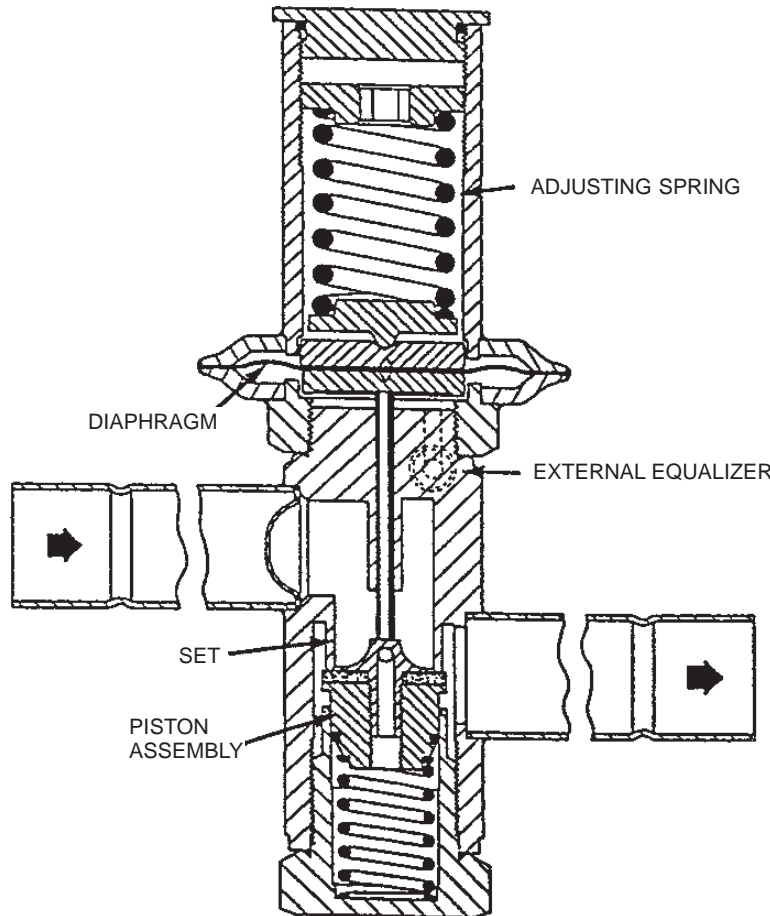

**FIGURE 2
CAPACITY CONTROL PIPING**

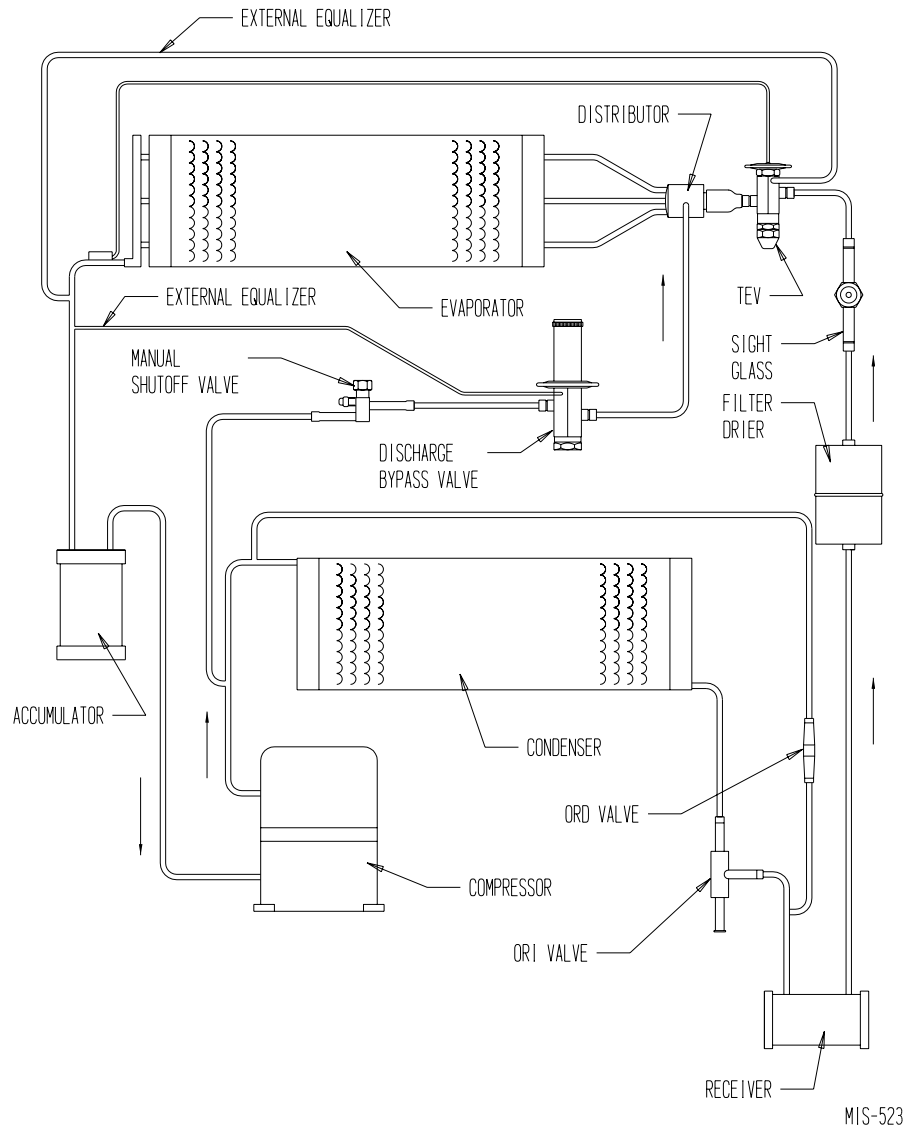

BYPASS TO EVAPORATOR INLET WITH DISTRIBUTOR

This method of application, illustrated in Figure 2, provides distinct advantages.

The primary advantage of this method is that the system thermostatic expansion valve will respond to the increased superheat of the vapor leaving the evaporator and will provide the liquid required for desuperheating. Also the evaporator serves as an excellent mixing chamber for the bypassed hot gas and the liquid-vapor mixture from the expansion valve. This ensures a dry vapor reaching the compressor suction. Oil return from the evaporator is also improved since the velocity in the evaporator is kept high by the hot gas.

EXTERNALLY EQUALIZED BYPASS VALVES

Since the primary function of the DBV is to maintain suction pressure, the compressor suction pressure is the control pressure and must be exerted on the underside of the valve diaphragm. When the DBV is applied as shown in Figure 2 where there is an appreciable pressure drop between the valve outlet and the compressor suction, the externally equalized valve must be used. This is true because when the valve opens a sudden rise in pressure occurs at the valve outlet.

A thermal expansion valve with external equalizer and a special refrigerant distributor to allow hot gas injection at the inlet of the evaporator by feeding the side connection distributor is utilized. The expansion valve also has a rapid pressure balancing feature to allow system pressure equalization during any periods the compressor may be turned off.

HEAD PRESSURE CONTROL

Design of air conditioning system utilizing air cooled condensing units involves two main problems which must be solved if the system is to operate reliably and economically - High ambient and low ambient operation. If the condensing unit is properly sized, it will operate satisfactorily during extremely high ambient temperatures. However since most units will be required to operate at ambient temperatures below their design dry bulb temperature during most of the year, the solution to low ambient operation is more complex.

Without good head pressure control during low ambient operation, the system can experience both running cycle and off-cycle problems. Two running cycle problems are of prime concern:

1. Since the pressure differential across the thermostatic expansion valve port affects the rate of refrigerant flow, low head pressure generally caused insufficient refrigerant to be fed to the evaporator.
2. Any system using hot gas for compressor capacity control must have a normal head pressure to operate properly. In either case, failure to have sufficient head pressure will result in low suction pressure and/or iced evaporator coils.

The primary off-cycle problem is the possible inability to get the system on-the-line if the refrigerant has migrated to the condenser. Insufficient flow through the TEV will cause a low suction pressure which results in compressor cycling.

When low ambient conditions are encountered during operation on air cooled systems with the resultant drop in condensing pressure, head pressure control's purpose is to hold back enough of the condensed liquid refrigerant so that some of the condenser surface is rendered inactive. This reduction of active condensing surface results in a rise in condensing pressure and sufficient liquid line pressure for normal system operation.

The head pressure control valve is used in conjunction with a receiver to allow for proper head pressure control. Any system using hot gas for capacity control must have a normal head pressure to operate properly.

ORI VALVE OPERATION

The ORI head pressure control valve is an inlet pressure regulating valve and responds to changes in condensing pressure only. The valve designation stands for Opens on Rise of Inlet pressure. As shown in Figure 3, the outlet pressure is exerted on the underside of the bellows and on top of the seat disc. Since the effective area of

the bellows is equal to the area of the port, the outlet pressure cancels out the inlet pressure acting on the bottom of the seat disc opposes the adjusting spring force. These two forces are the operating forces of the ORI.

When the outdoor ambient temperature changes the ORI opens or closes in response to the change in condensing pressure. An increase in inlet pressure above the valve setting tends to open the valve. If the ambient temperature drops the condenser capacity is increased and the condensing pressure drops off. This causes the ORI to start to close or assume a throttling position.

The head pressure control valve will begin to throttle when the condensing pressure falls below the setting of the valve. This restricts the flow of liquid from the condenser causing the refrigerant to back up into the condenser and raising the head pressure. The valve is factory set to maintain a nominal 225 psig minimum head pressure. Head pressures of higher than 225 psig will occur during any conditions of indoor or outdoor loading that would dictate so.

FIGURE 3
HEAD PRESSURE CONTROL VALVE

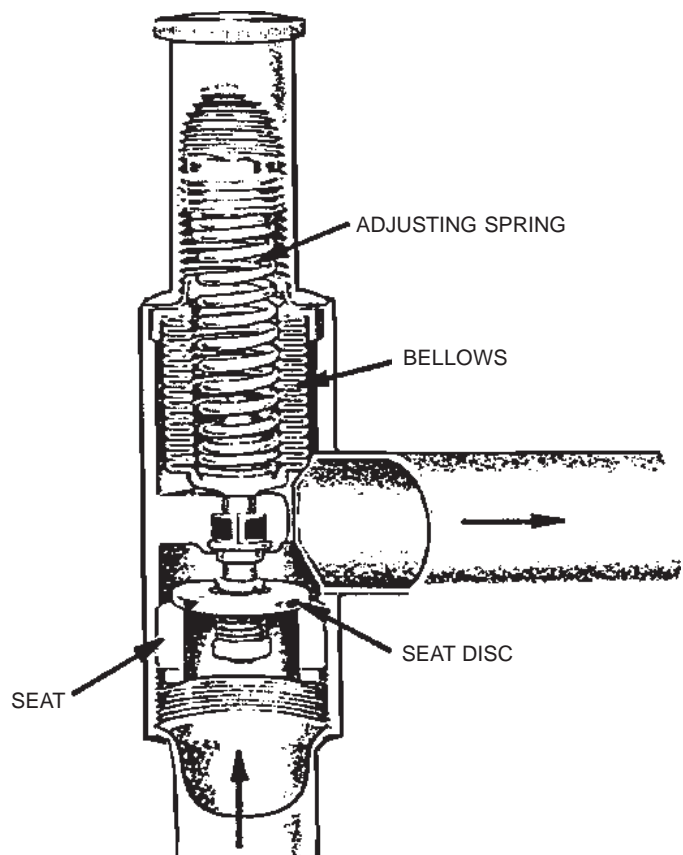
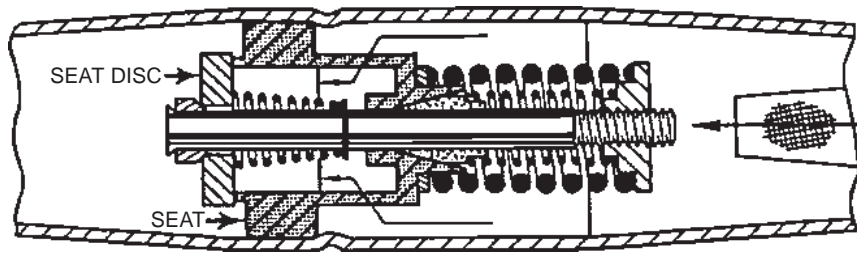

FIGURE 4
ORD PRESSURE DIFFERENTIAL VALVE



ORD VALVE OPERATION

The ORD valve is a pressure differential valve that responds to changes in the pressure difference across the valve. Refer to Figure 4. The valve designation stands for Open on Rise of Differential pressure. Therefore, the ORD is dependent on some other control valve or action for its operation; and in this respect, it is used with the ORI head pressure control.

As the ORI valve starts to throttle the flow of liquid refrigerant from the condenser, a pressure differential is created across the ORD. When the differential reaches 25 psi, the ORD starts to open and bypasses hot gas to the liquid line. As the differential increases, the ORD opens further until its full stroke is reached at a differential of 30 psi. The hot gas flowing through the pressure differential valve heats up the cold liquid being passed by the head pressure control valve, and the liquid refrigerant reaching the receiver is warm and with sufficient pressure to assure proper expansion valve operation.

ADJUSTABLE ORI / ORD SYSTEM OPERATION

The adjustable ORI head pressure control valve and the nonadjustable ORD pressure differential valve comprise an improved system of head pressure control.

The operation of the ORI / ORD system is such that a constant receiver pressure is maintained for normal system operation.

As shown in Figure 5, the ORI is located in the liquid line between the condenser and the receiver. The ORD is located in a hot gas line bypassing the condenser. During periods of low ambient temperature the condensing pressure falls until it approaches the setting of the ORI valve. The ORI then throttles, restricting the flow of liquid from the condenser. This causes refrigerant to back up in the condenser thus reducing the active condenser surface. This raises the condensing pressure. Since it is really receiver pressure that needs to be maintained, the bypass line with the ORD is required.

FIGURE 5
ORI / ORD SYSTEM

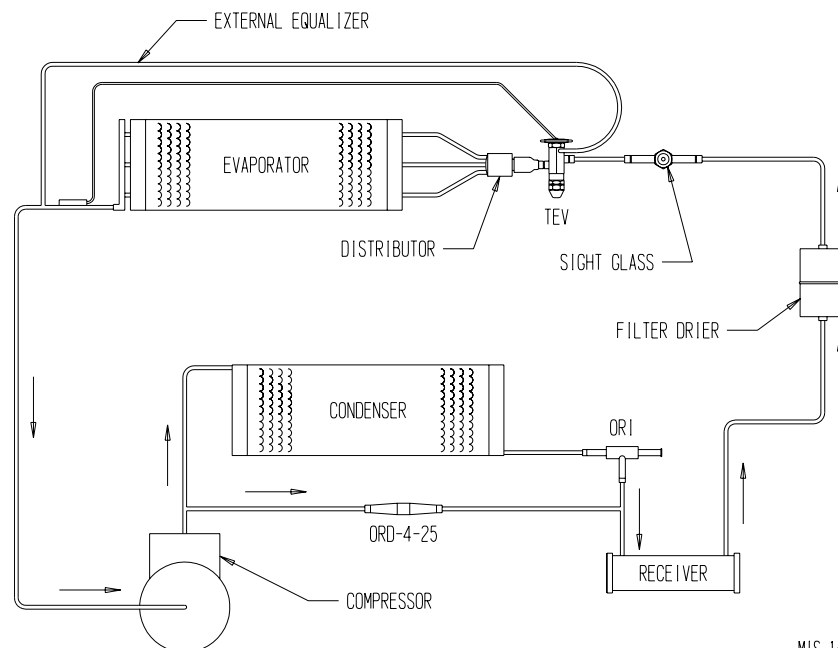

MIS-1419

REFRIGERANT CHARGE

When “refrigerant side” head pressure control is utilized on a system, two additional considerations must be completely analyzed. First of all, there must be the correct amount of refrigerant to flood the condenser at the lowest expected ambient and still have enough charge in the system for proper operation. A shortage of refrigerant will cause hot gas to enter the liquid line and the expansion valve and refrigeration will cease. Too much charge doesn’t cause any operating difficulties during the low ambient season; however, this will cause high head pressures during the summer season when head pressure control is not required.

Secondly, the receiver must have sufficient capacity to hold all of the liquid refrigerant in the system since it will be returned to the receiver when high ambient conditions prevail. If the receiver is too small, liquid refrigerant will be held back in the condenser during the high ambient conditions and excessively high discharge pressure will be experienced.

The receiver has been sized to hold the necessary amount of refrigerant required during light load conditions so the head pressure system can function properly, and also to accommodate the surplus charge that occurs under periods of normal loading at the warmer outdoor temperatures. Any erratic operating during light load conditions either inside or outside could be attributed to an undercharge of refrigerant even though the unit may operate normally at higher temperatures. Because of the complexity of the system design and operation, the only way to assure correct system charge and operating characteristics over the entire design

operating range of the unit is to completely recharge the system with the total amount of R-22 shown on the unit serial plate after proper leak test and evacuation procedures have been followed.

REFRIGERANT PIPING AND FLOW DIAGRAM

Earlier in this manual Figure 2 reviewed the components used in System Capacity Control. Please refer to Figure 5 for complete piping diagram including System Capacity and Head Pressure Control.

TROUBLESHOOTING GUIDE

Troubleshooting the refrigerant system can be quite complicated because of the number of refrigerant valves in the system. There are two devices installed in the system to aid in this process:

1. A liquid line sight glass is located directly above the filter drier. If a solid column of refrigerant is not present during normal operation, an undercharge or defective pressure differential valve should be suspected.
2. A manual shutoff valve is installed in the feed line from the discharge line to the hot gas bypass valve. This valve is normally open but can be closed down by service personnel to help in evaluating system operation should it be necessary.

Please refer to Figure 6, Refrigerant System Troubleshooting Guide, for complete details.

WIRING

TYPICAL CONTROL CIRCUIT WIRING

The air conditioning portion of the system is designed for continuous run type of operation for those types of installations that require cooling operation without cycling of the compressor during critical periods (see earlier discussion titled “System Capacity Control”).

Many systems may also employ electric heaters for certain conditions that may necessitate heating rather than cooling operation.

The control of the space temperature is dependent upon several variables such as basic size of the air conditioner; structure design; internal heat generation from people, lights and equipment; and external weather conditions.

A generally recommended control circuit would consist of conventional heat/cool wall thermostat with an additional SPST toggle switch used to provide a manual cooling switch (continuous run type of operation). This would allow the flexibility of having the wall thermostat cycle the compressor during noncritical periods, and when the manual cooling switch is thrown (closed) the compressor would run all of the time. A secondary feature of this type of setup is that the manual cooling switch can be activated, and at the same time the wall thermostat can be set for heating and the thermostat

adjusted to the desired temperature. This would allow the electric heater to cycle on demand to help regulate the space temperature. This type of operation may prove helpful if the basic air conditioner is way oversized or there are temporary conditions when a major portion of the heat producing equipment within the building is shut down for some reason.

Shown in Figure 7 is a typical 24V connection.

WIRING – MAIN POWER

Refer to the rating plate for wire sizing information and maximum fuse or HACR type circuit breaker size. Each outdoor unit is marked with a Minimum Circuit Ampacity. The Minimum Circuit Ampacity for Hot Gas Bypass models is calculated for the concurrent operation of the air conditioner and electric heaters. Many Hot Gas Bypass installations require continuous operation of the compressor with a room air temperature being maintained by cycling the electric heat strips on and off. This leads to the higher than normal Minimum Circuit Ampacity of the Hot Gas Bypass units.

Since the field wiring must be sized to carry the concurrent current of both compressor and electric heaters, the field wiring must be sized to carry the Minimum Circuit Ampacity current. See instruction sheet for further details.

FIGURE 7
LOW VOLTAGE WIRING

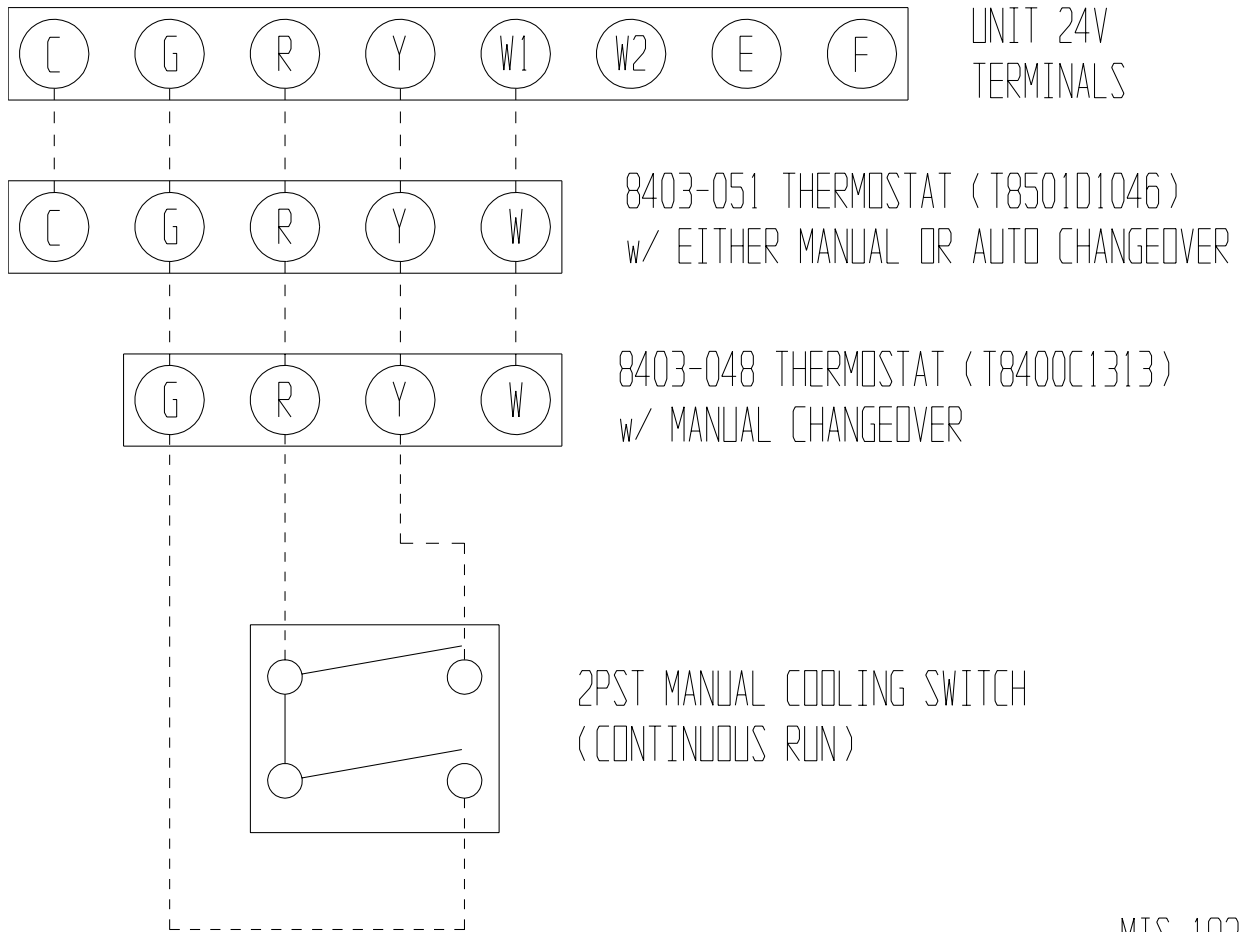

MIS-1921

**FIGURE 8
HOT GAS BYPASS SYSTEM
TYPICAL PIPING DIAGRAM**

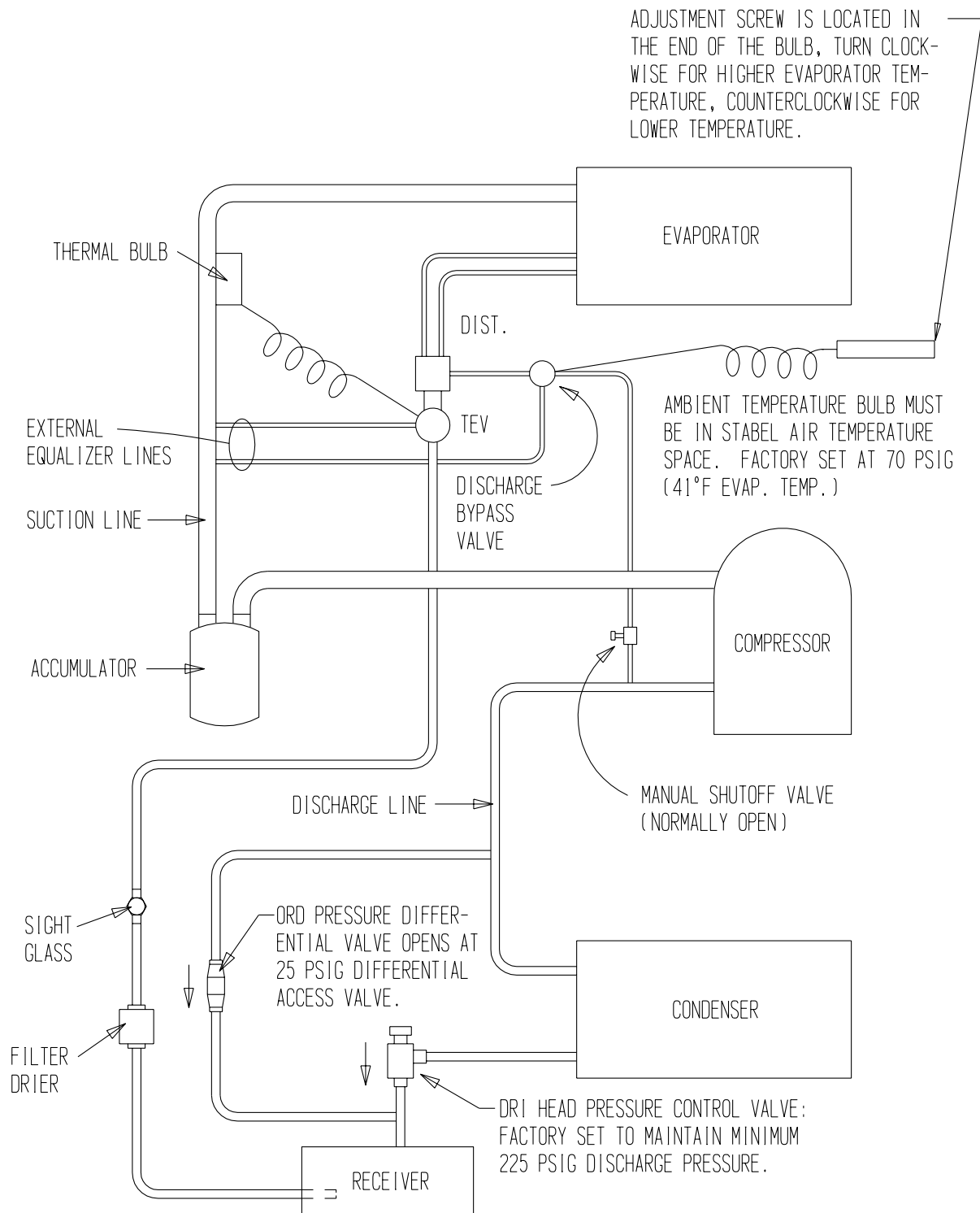

MIS-100

**FIGURE 9
HOT GAS BYPASS SYSTEM
COMPRESSOR BURNOUT CLEANUP PROCEDURE**

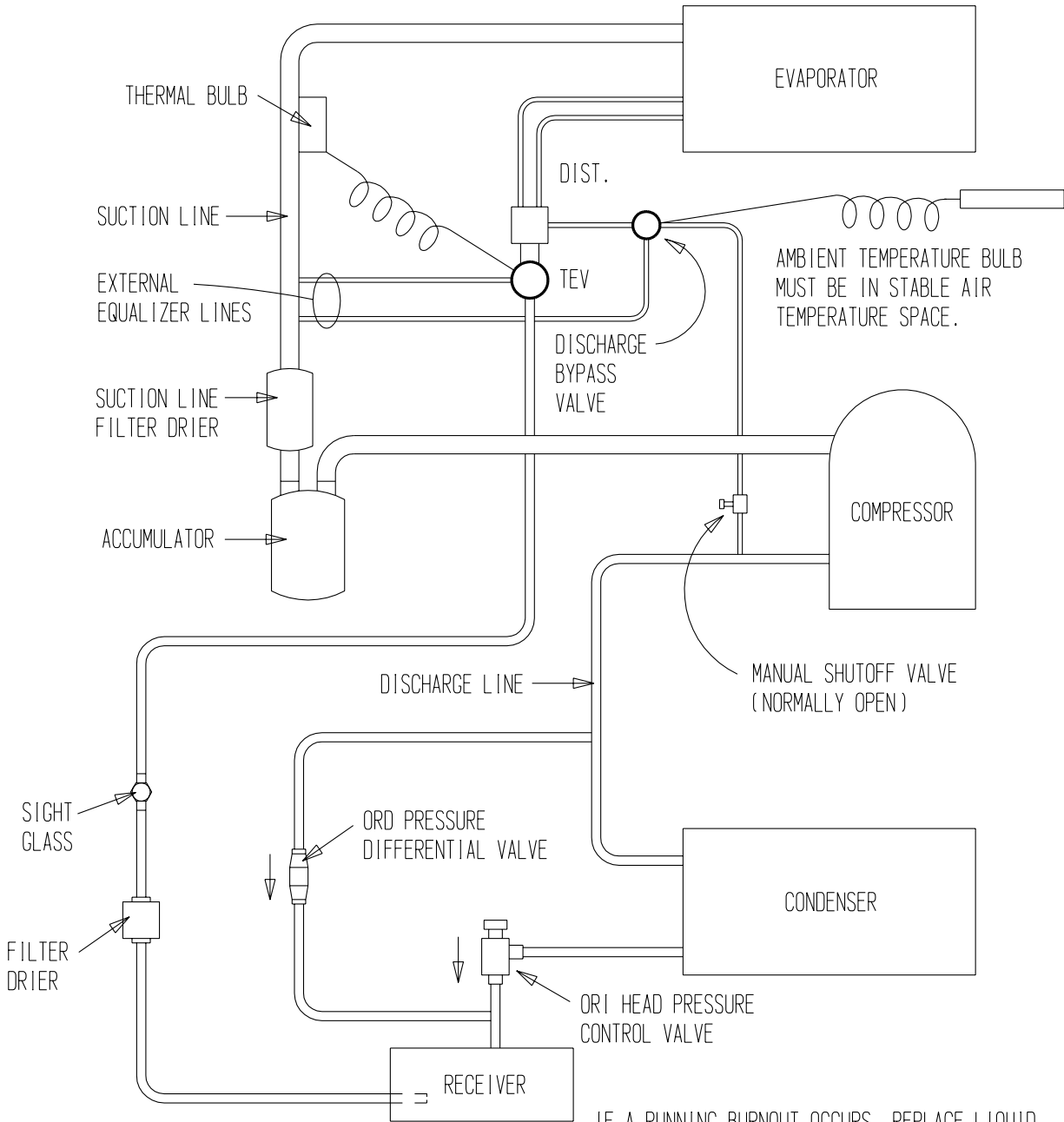

IF A RUNNING BURNOUT OCCURS, REPLACE LIQUID LINE FILTER DRIER & ACCUMULATOR & INSTALL A SUCTION LINE FILTER DRIER. CLEAN OR REPLACE HOT GAS BYPASS VALVE. TEV, ORP DIFFERENTIAL VALVE, ORI CONTROL VALVE, DISCHARGE, LIQUID & HOT GAS TUBING. THE ORI & ORP VALVES HAVE MESH SCREENS THAT MUST BE CLEANED.