INSTALLATION INSTRUCTIONS

WALL MOUNTED PACKAGE AIR CONDITIONERS

Model:
WE121

**THIS MODEL USES REFRIGERANT R-407C
and IS FOR 50HZ OPERATION.**



CLIMATE CONTROL SOLUTIONS

Bard Manufacturing Company
Bryan, Ohio 43606
Since 1914...Moving ahead, just as
planned.

Manual : 2100-364
Supersedes:
File: Volume III Tab 16
Date: 08-20-01

CONTENTS

Getting Other Informations and Publications

Wall Mount General Information

Air Conditioner Wall Mount Model Nomenclature	2
Shipping Damage	4
General	4
Duct Work	4
Filters	4
Fresh Air Intake	5
Condensate Drain	5

Installation Instructions

Wall Mounting Information	6
Mounting the Unit	6
Wiring – Main Power	11
Wiring – Low Voltage Wiring	11

Figures

Figure 1 Unit Dimensions	3
Figure 2 Blower Damper Assembly	5
Figure 3 Mounting Instructions Using CSRG-1	7
Figure 4 Mounting Instructions	8
Figure 5 Wall Mounting Instructions	9
Figure 6 Wall Mounting Instructions	9
Figure 7 Common Wall Mounting Instructions	10
Figure 8 Low Voltage Wiring	12
Figure 9 Fan Blade Setting Dimensions	15

Start Up

Important Installer Note	13
Service Hints	13
High Pressure Switch	13
Sequence of Operation	13
Compressor Control Module	13
Adjustments	14
Pressure Service Ports	14

Troubleshooting

Fan Blade Setting Dimension	15
Refrigerant Charge	15
Pressure Table	16
Option Field Installed Accessories	16

R-407C Refrigerant

Service Procedure & Considerations	17
Charging	17
Leaks	17

Tables

Table 1 Electric Heat Table	2
Table 2 Electrical Specifications	2
Table 3 Thermostat Wire Size	11
Table 4 Wall Thermostats	11
Table 5 Fan Blade Dimensions	15
Table 6 Suction Line Temperatures	15
Table 7 Indoor Blower Performance	15
Table 8 Recommended Airflow Range	15
Table 9 Maximum ESP of Operation Electric Heat Only	15
Table 10 Pressure Table - Cooling	16
Table 11 Optional Accessories	16
Table 12 Temperature / Pressure Chart	18

GETTING OTHER INFORMATION AND PUBLICATIONS

These publications can help you install the air conditioner or heat pump. You can usually find these at your local library or purchase them directly from the publisher. Be sure to consult current edition of each standard.

National Electrical Code ANSI/NFPA 70

Standard for the Installation of ANSI/NFPA 90A
Air Conditioning and
Ventilating Systems

Standard for Warm Air Heating ANSI/NFPA 90B
and Air Conditioning Systems

Load Calculation for ACCA Manual J
Residential Winter and
Summer Air Conditioning

Duct Design for ACCA Manual D
Residential Winter and
Summer Air Conditioning
and Equipment Selection

FORMOREINFORMATION, CONTACT THESE PUBLISHERS:

ACCA Air Conditioning Contractors of America
1712 New Hampshire Avenue NW
Washington, DC 20009
Telephone: (202) 483-9370
Fax: (202) 234-4721

ANSI American National Standards Institute
11 West Street, 13th Floor
New York, NY 10036
Telephone: (212) 642-4900
Fax: (212) 302-1286

ASHRAE American Society of Heating, Refrigerating
and Air Conditioning Engineers, Inc.
1791 Tullie Circle, NE
Atlanta, GA 30329-2305
Telephone: (404) 636-8400
Fax: (404) 321-5478

NFPA National Fire Protection Association
Batterymarch Park
P.O. Box 9101
Quincy, MA 02269-9901
Telephone: (800) 344-3555
Fax: (617) 984-7057

Manufactured under the following U.S. patent numbers:

5,485,878 and 5,301,744

WALL MOUNT GENERAL INFORMATION

AIR CONDITIONER WALL MOUNT MODEL NOMENCLATURE

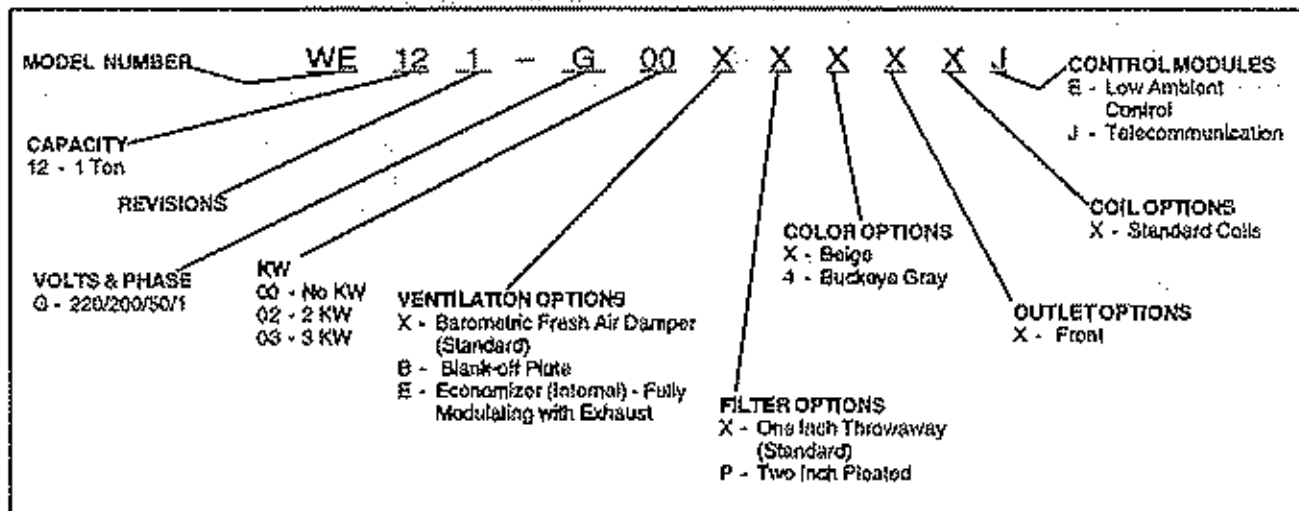

**TABLE 1
ELECTRIC HEAT TABLE**

Model	WE121-G			
	220V		200V	
	A	① BTU	A	① BTU
02	9.1	6,830	8.2	6,150
03	13.7	10,250	12.6	9,140

**TABLE 2
ELECTRICAL HEAT SPECIFICATIONS**

Models	Rated Volts and Phase	No. Field Power Circuits	① Minimum Circuit Ampacity	① Maximum External Fuse or Circuit Breaker	② Field Power Wire Size	② Ground Wire Size
WE121-G00	220/200/50/1	1	7	15	14	14
-G02		1	13	15	14	14
-G03		1	20	20	12	12

- ① Maximum size of the time delay fuse or HACR type circuit breaker for protection of field wiring conductors.
- ② Based on 75° C copper wire. All wiring must conform to NEC and all local codes.
- ③ These "Minimum Circuit Ampacity" values are to be used for sizing the field power conductors. Refer to the National Electrical Code (latest revision), article 310 for power conductor sizing.

CAUTION: When more than one field power conductor circuit is run through one conduit, the conductors must be derated. Pay special attention to note B of table 310 regarding Ampacity Adjustment Factors when more than 3 conductors are in a raceway.

**FIGURE 1
UNIT DIMENSIONS**

UNIT	WIDTH (W)	DEPTH (D)	HEIGHT (H)	SUPPLY			RETURN			J (*)	I	F	G (*)	K	L	H
				A	B	C	B	C	B							
WE121	20-1/8	14-5/8	46	5	17	10	17	10	17	20-1/8	18-1/4	2 DR S	19-7/8	20-1/4	2-1/2	31-1/4

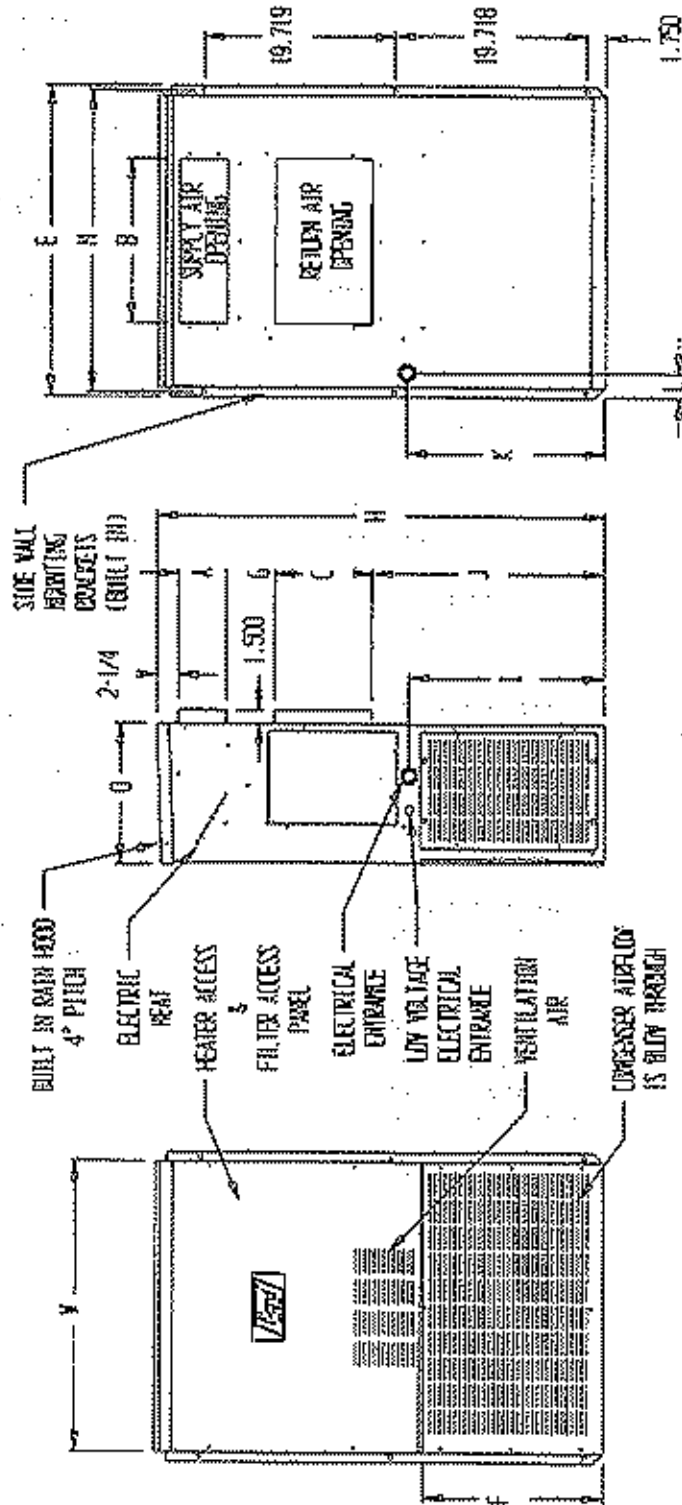

FRONT VIEW
RIGHT SIDE VIEW
BACK VIEW

(*) POSITION OF RETURN AIR PLACES ARE INTERCHANGEABLE BETWEEN TWO POSITIONS.
FACTORY BUILT AT 5 INCHES

MS-500

SHIPPING DAMAGE

Upon receipt of equipment, the carton should be checked for external signs of shipping damage. If damage is found, the receiving party must contact the last carrier immediately, preferably in writing, requesting inspection by the carrier's agent.

GENERAL

The equipment covered in this manual is to be installed by trained, experienced service and installation technicians.

The refrigerant system is completely assembled and charged. All internal wiring is complete.

The unit is designed for use with or without duct work. Flanges are provided for attaching the supply and return air ducts.

These instructions explain the recommended method to install the air cooled self-contained unit and the electrical wiring connections to the unit.

These instructions and any instructions packaged with any separate equipment required to make up the entire air conditioning system should be carefully read before beginning the installation. Note particularly "Starting Procedure" and any tags and/or labels attached to the equipment.

While these instructions are intended as a general recommended guide, they do not supersede any national and/or local codes in any way. Authorities having jurisdiction should be consulted before the installation is made. See Page 1 for information on codes and standards.

Size of unit for a proposed installation should be based on heat loss calculation made according to methods of Air Conditioning Contractors of America (ACCA). The air duct should be installed in accordance with the Standards of the National Fire Protection Association for the Installation of Air Conditioning and Ventilating Systems of Other Than Residence Type, NFPA no. 90A, and Residence Type Warm Air Heating and Air Conditioning Systems, NFPA No. 90B. Where local regulations are at a variance with instructions, installer should adhere to local codes.

DUCT WORK

All duct work, supply and return must be properly sized for the design air flow requirement of the equipment. Air Conditioning Contractors of America (ACCA) is an excellent guide to proper sizing. All duct work or portions thereof not in the conditioned space should be properly insulated in order to both conserve energy and prevent condensation or moisture damage.

Refer to Table 9 for maximum static pressure available for duct design.

Design the duct work according to methods given by the Air Conditioning Contractors of America (ACCA). When duct runs through unheated spaces, it should be insulated with a minimum of one inch of insulation. Use insulation with a vapor barrier on the outside of the insulation. Flexible joints should be used to connect the duct work to the equipment in order to keep the noise transmission to a minimum.

Ducts through the walls must be insulated and all joints taped or sealed to prevent air or moisture entering the wall cavity.

Some installations may not require any return air duct. It is recommended that on this type of installation that a filter grille be located in the wall. Filters must be of sufficient size to allow a maximum velocity of 400 FPM.

NOTE: If no return air duct is used, applicable installation codes may limit this cabinet to installation only in a single story structure.

FILTERS

A one inch throwaway filter is supplied with each unit. The filter slides into position making it easy to service. This filter can be serviced from the outside by removing the service door. A two inch pleated filter is also available as an optional accessory. The internal filter brackets are adjustable to accommodate the 2 inch filter by bending the metal tabs holding the 1 inch filter down. There are two tabs on each side of the filter.

FRESH AIR INTAKE

All units are built with fresh air inlet slots punched in the service panel.

If the unit is equipped with a fresh air damper assembly, the assembly is shipped already attached to the unit. The damper blade is locked in the closed position. To allow the damper to operate, the maximum and minimum blade position stops must be installed. See Figure 2.

Capacity and efficiency is based upon the fresh air blank-off plate in place and is recommended for maximum energy efficiency.

The blank-off plate is available upon request from the factory and is installed in place of the fresh air damper shipped with each unit.

CONDENSATE DRAIN

This unit employs an automatic condensate disposal system consisting of a base drain pan, drain valve and fan blade with slinger ring. A plastic drain hose extends from the evaporator drain pan at the top of the unit to the base drain pan at the bottom. At temperatures above 40°, the drain valve located between the condenser coil and fan shroud is closed allowing water to build up in the base to a height of 5/8" to 3/4". The fan blade with slinger then rotates in this water and throws the water onto the condenser coil. This disposes of the water by evaporating it on the hot condenser.

At temperatures below 40°, the drain valve opens draining the base pan and preventing freeze ups that could damage the coil or fan blade.

FIGURE 2
FRESH AIR DAMPER

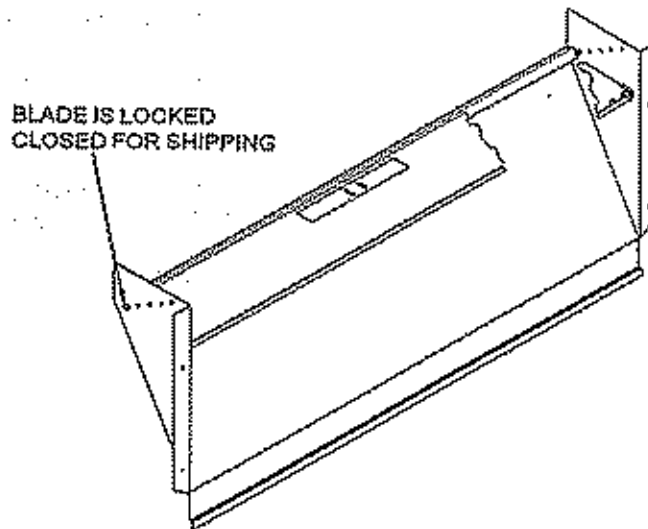

MIS-333

INSTALLATION INSTRUCTIONS

WALL MOUNTING INFORMATION

1. These units are secured by wall mounting brackets which secure the unit to the outside wall surface at both sides.
2. On wood frame walls, the wall construction must be strong and rigid enough to carry the weight of the unit without transmitting any unit vibration.
3. Concrete block walls must be thoroughly inspected to insure that they are capable of carrying the weight of the installed unit.

PROPER UNIT PLACEMENT

Refer to Technical Bulletin TB01-4 "Wall Mount Equipment Clearance for Proper Operation. This bulletin will provide information concerning the placement of units as to clearance between dual unit installation (mounted on common wall) of units discharging against a wall, or essentially solid barrier, and units discharging against opposing (facing) units.

MOUNTING THE UNIT

1. Two holes, for the supply and return air openings, must be cut through the wall as shown in Figure 4.

NOTE: If the combination SUPPLY/RETURN Grille Assembly model CRSG-1 is to be used in conjunction with this unit a different size wall opening is required. See Figure 3.

2. Locate and mark lab bolt locations and bottom mounting bracket location, if desired. See Figure 4.
3. Hook top rain flashing under back bend of top. Top rain flashing is shipped attached to the back of the unit on the right side.
4. Position unit in opening and secure with 5/16 lag bolts; use 7/8 inch diameter flat washers on the lab bolts.
5. Secure rain flashing to wall and caulk across entire length of top. See Figures 3 and 4.
6. For additional mounting rigidity, the return air and supply air frames or collars can be drilled and screwed or welded to the structural wall itself (depending upon wall construction). Be sure to observe required clearance if combustible wall.
7. On side by side installations, maintain a minimum of 20 inches clearance on right side to allow access to control panel and allow proper airflow to outdoor coil. Additional clearance may be required to meet local or national codes.

FIGURE 3
MOUNTING INSTRUCTIONS WHEN USING
THE COMBINATION SUPPLY / RETURN GRILLE ASSEMBLY CSRG-1

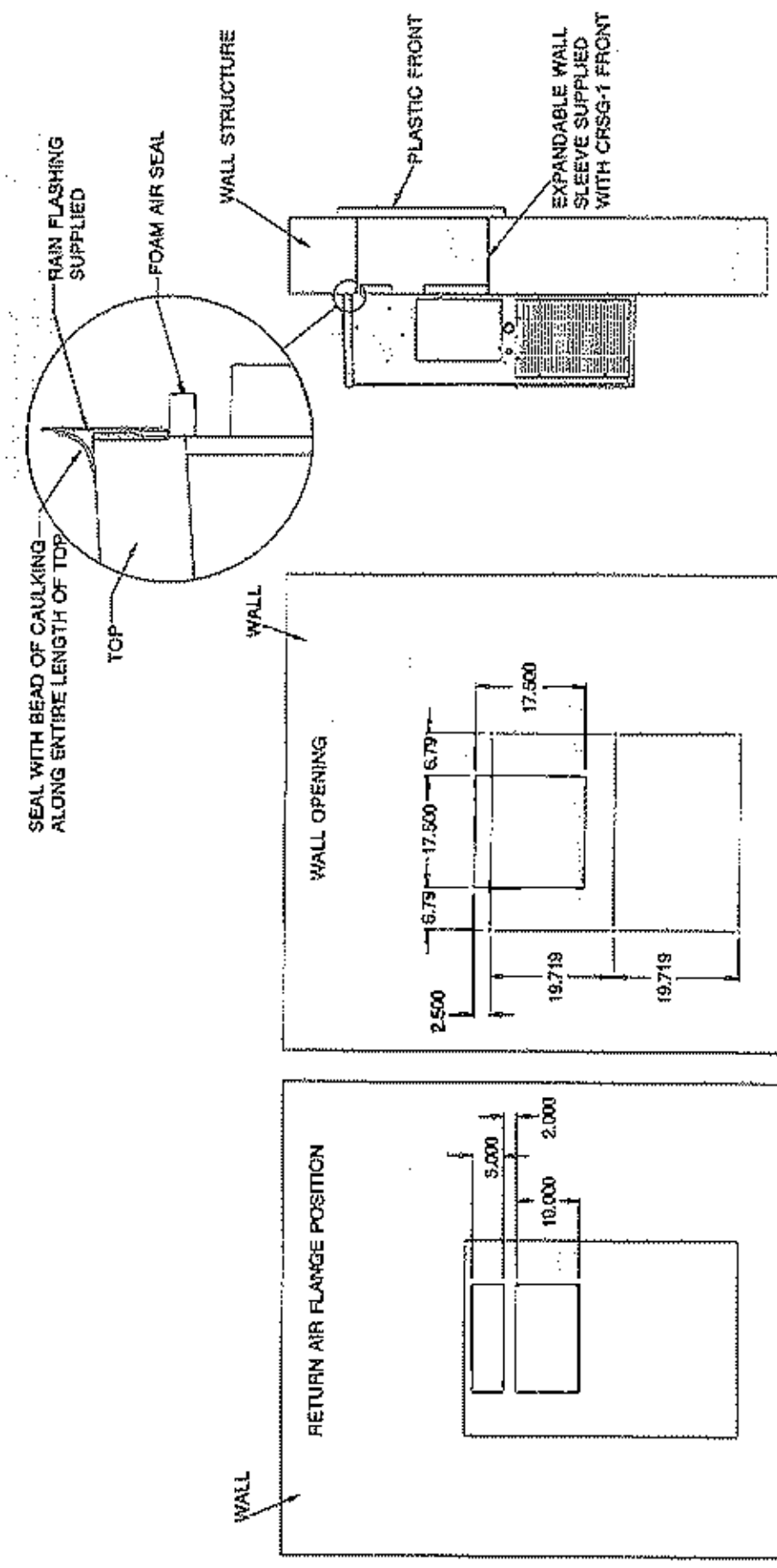

NOTE:
 IT IS RECOMMENDED THAT A BEAD OF SILICONE CAULKING BE PLACED BEHIND THE SIDE MOUNTING FLANGES AND UPPER TOP FLASHING AT THE TIME OF INSTALLATION.

MS-1438

**FIGURE 4
MOUNTING INSTRUCTIONS**

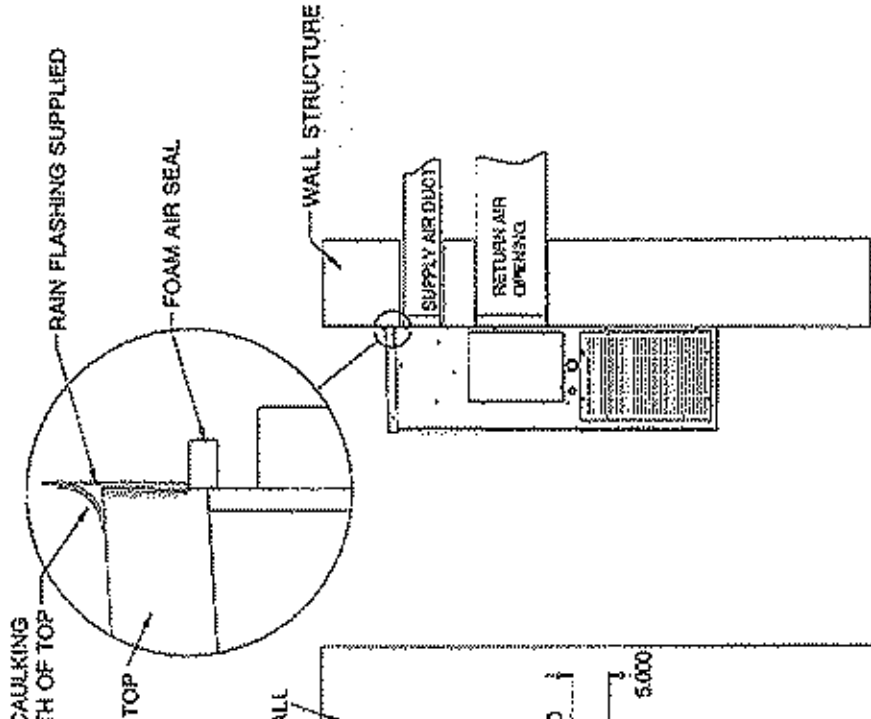

SEAL WITH BEAD OF CAULKING
ALONG ENTIRE LENGTH OF TOP

THIS INFORMATION DOES NOT APPLY IF
CSRQ-1 COMBINATION SUPPLY / RETURN
GRILLE ASSEMBLY IS TO BE USED. SEE
FIGURE 3.

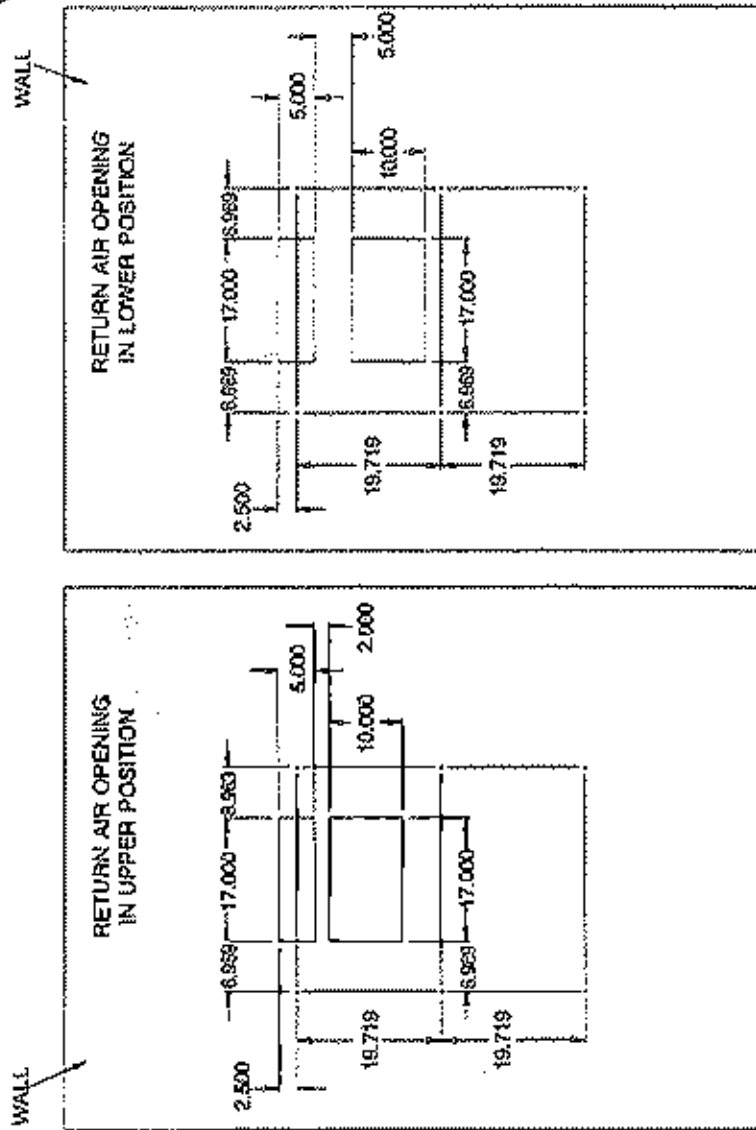

NOTE:
IT IS RECOMMENDED THAT A BEAD OF
SILICONE CAULKING BE PLACED BEHIND
THE SIDE MOUNTING FLANGES AND
UNDER TOP FLASHING AT THE TIME OF
INSTALLATION.

FIGURE 5 WALL MOUNTING INSTRUCTIONS

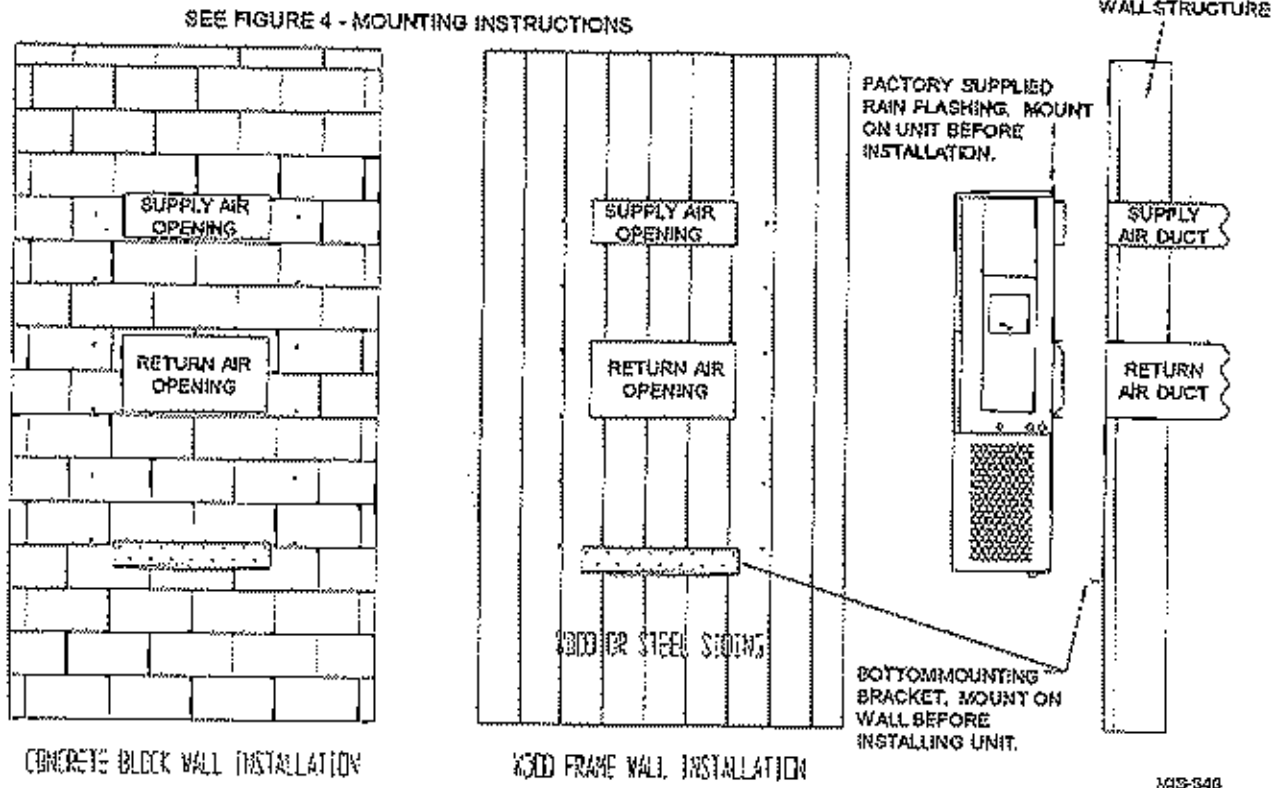
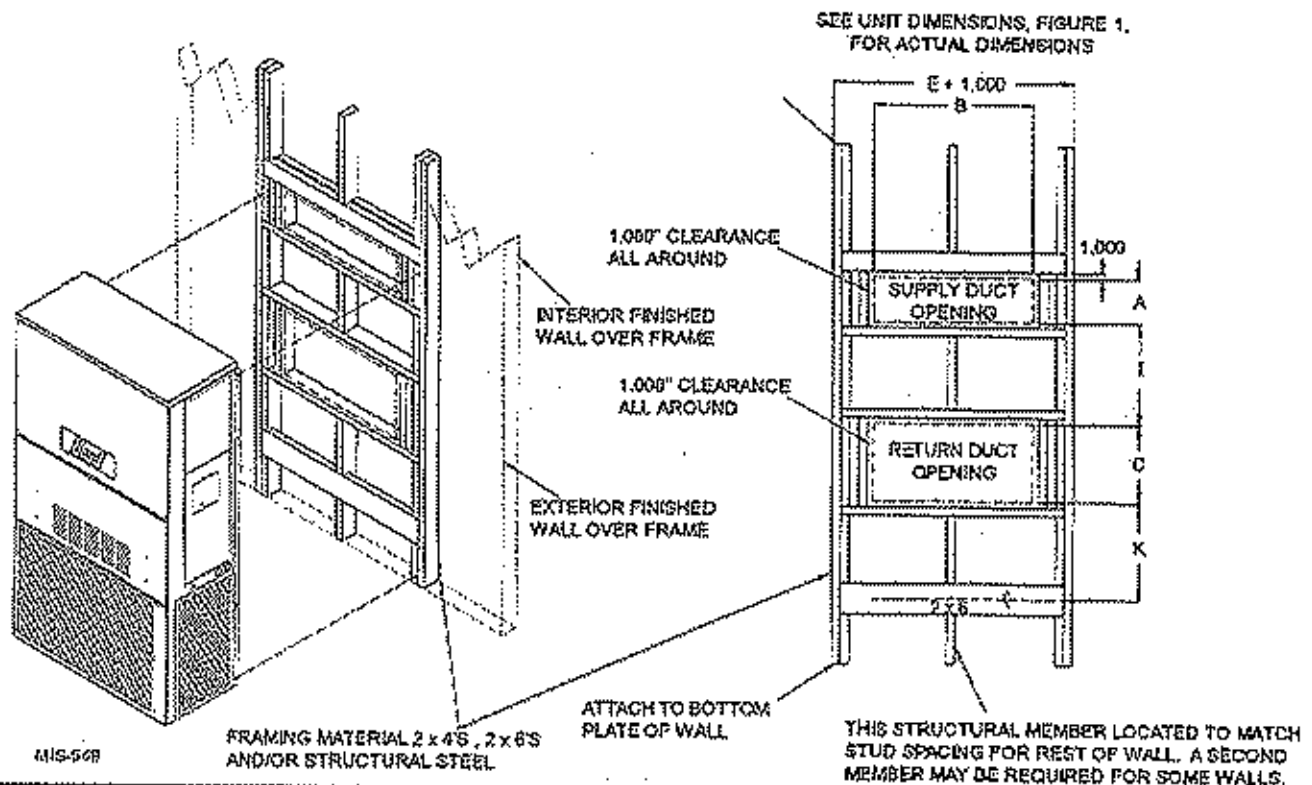
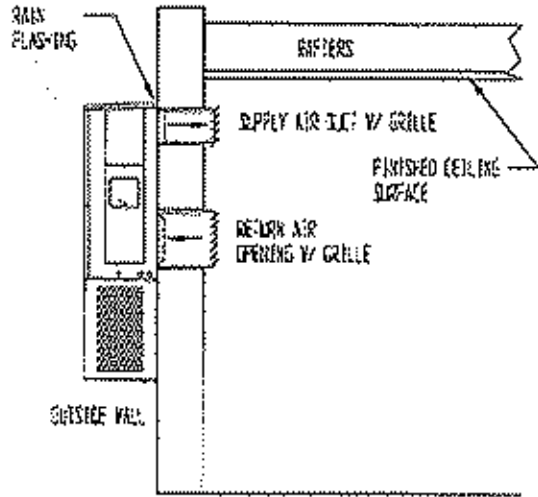

FIGURE 6 WALL MOUNTING INSTRUCTIONS



**FIGURE 7
COMMON WALL-MOUNTING INSTALLATIONS**



**FREE AIR FLOW
NO DUCT**

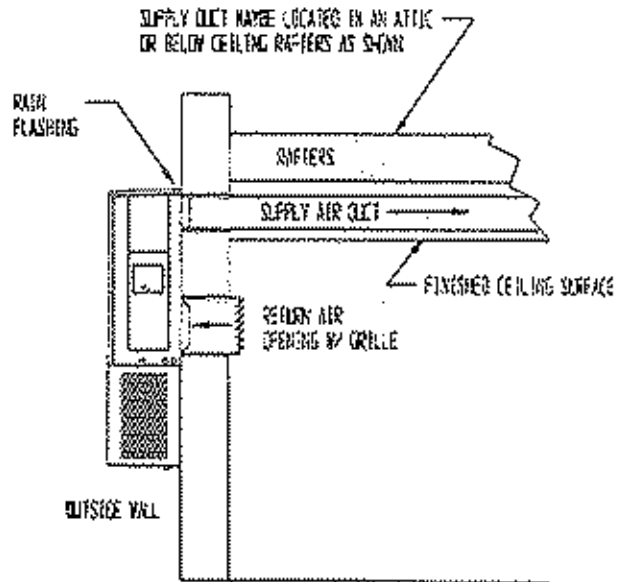

**DUCTED SUPPLY
RETURN AT UNIT**

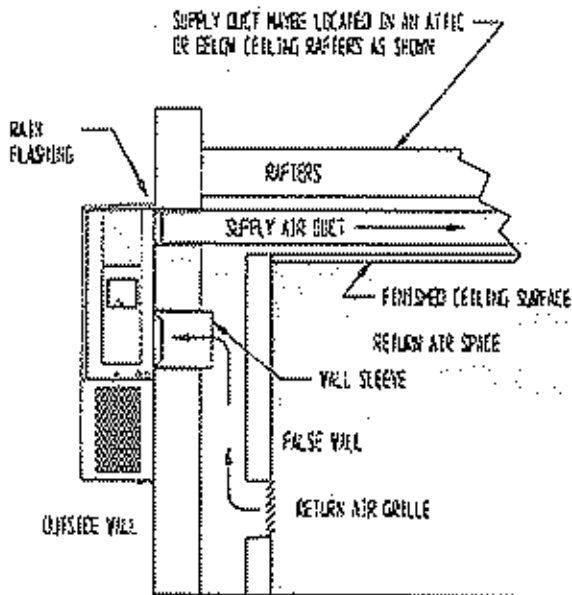

FALSE WALL INSTALLATION

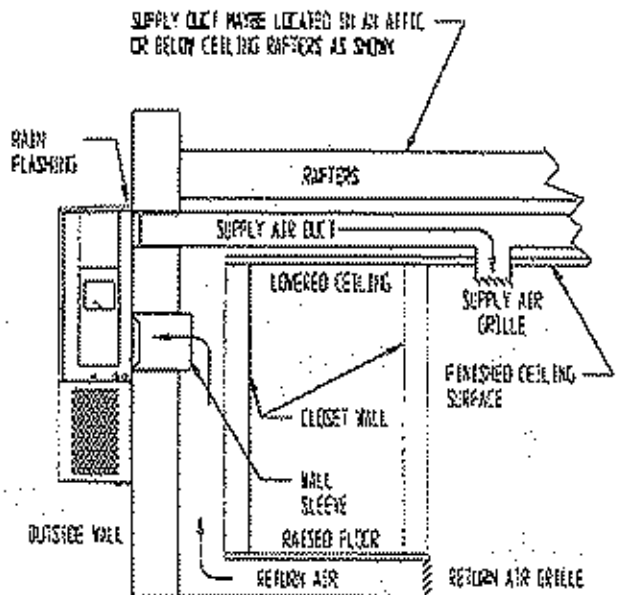

CLOSET INSTALLATION

MD-500

WIRING – MAIN POWER

Refer to the unit rating plate for wire sizing information and maximum fuse or "HACR" type circuit breaker size. Each outdoor unit is marked with a "Minimum Circuit Ampacity". This means that the field wiring used must be sized to carry that amount of current. Depending on the installed KW of electric heat, there may be two field power circuits required. If this is the case, the unit serial plate will so indicate. All models are suitable only for connection with copper wire. Each unit and/or wiring diagram will be marked "Use Copper Conductors Only". These instructions *must be* adhered to. Refer to the National Electrical Code (NEC) for complete current carrying capacity data on the various insulation grades of wiring material. All wiring must conform to NEC and all local codes.

The electrical data lists fuse and wire sizes (75°C copper) for all models, including the most commonly used heater sizes. Also shown are the number of field power circuits required for the various models with heaters.

The unit rating plate lists a "Maximum Time Delay Relay Fuse" or "HACR" type circuit breaker that is to be used with the equipment. The correct size must be used for proper circuit protection and also to assure that there will be no nuisance tripping due to the momentary high starting current of the compressor motor.

WIRING – LOW VOLTAGE WIRING

230V/208, 1 phase equipment use dual primary voltage transformers. All equipment leaves the factory wired on 240V tap. For 208V operation, reconnect from 240V to 208V tap. The acceptable operating voltage range for the 240 and 208V taps are:

TAP	RANGE
240	253 - 216
208	220 - 187

NOTE: The voltage should be measured at the field power connection point in the unit and while the unit is operating at full load (maximum amperage operating condition).

Five (5) wires should be run from thermostat subbase to the 24V terminal board in the unit. A five conductor, 18 gauge copper, color-coded thermostat cable is recommended. The connection points are shown in Figure 8 on Page 12.

**TABLE 3
THERMOSTAT WIRE SIZE**

Transformer VA	FLA	Wire Gauge	Maximum Distance in Feet
40	2.3	20 Gauge	45
		18 Gauge	60
		16 Gauge	100
		14 Gauge	160
		12 Gauge	250

**TABLE 4
WALL THERMOSTAT AND SUBBASE COMBINATIONS**

Thermostat	Subbase	Predominate Features
8403-019 T874C1760	8404-012 Q574A1001	1 stage cool, 2 stage heat System: heat-auto-cool Fan: on-auto
8403-002 T87F3111	8404-003 Q539A1220	1 stage heat, 1 stage cool System: heat-off-cool Fan: on-auto
8403-009 1F56-318	----	1 stage heat, 1 stage cool System: heat-off-cool Fan: on-auto
8403-035 1F95-80	----	Programmable Electronic

**FIGURE 8
LOW VOLTAGE WIRING**

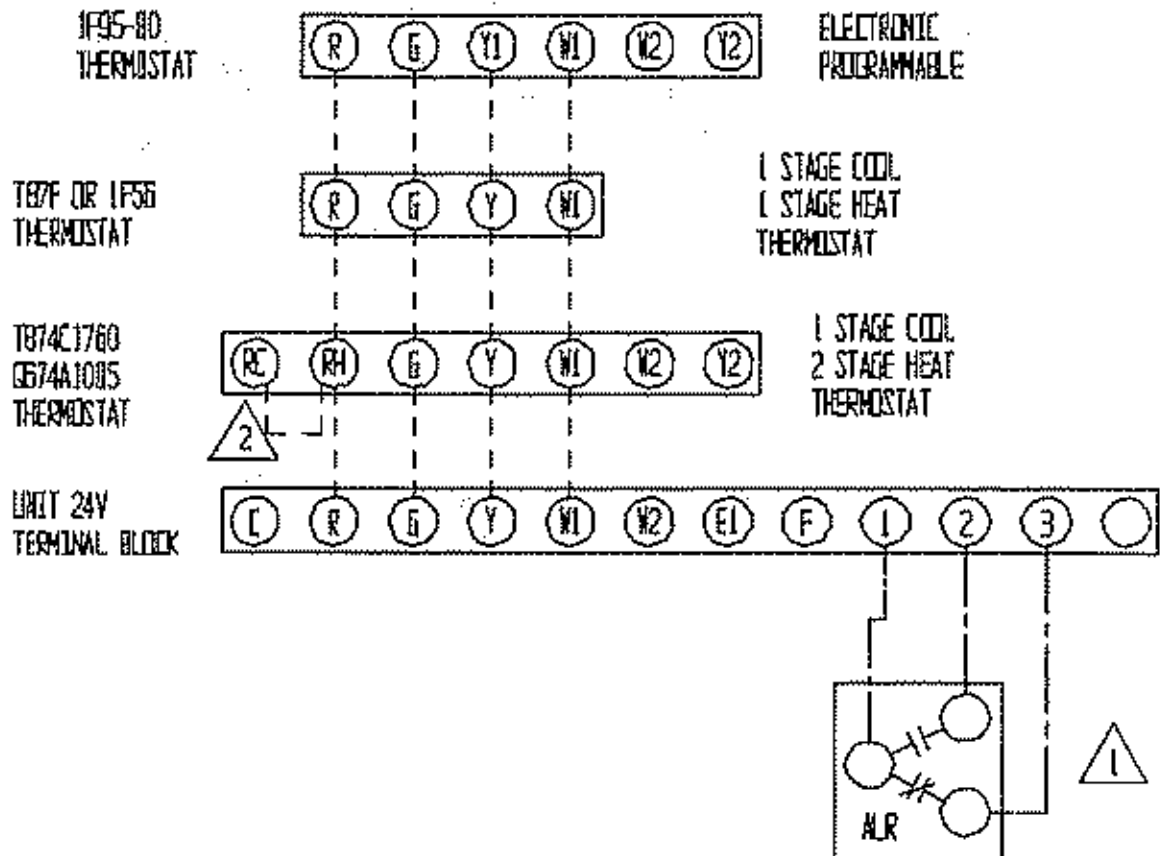

OPTIONAL ALARM RELAY PROVIDED ON UNITS WITH CONTROL MODULE "H" OR "J" INSTALLED. CONTACT RATING 24VAC @ 125VA



FIELD INSTALLED PER INSTRUCTIONS

OPTIONAL ECONOMIZER LOW VOLTAGE WIRING

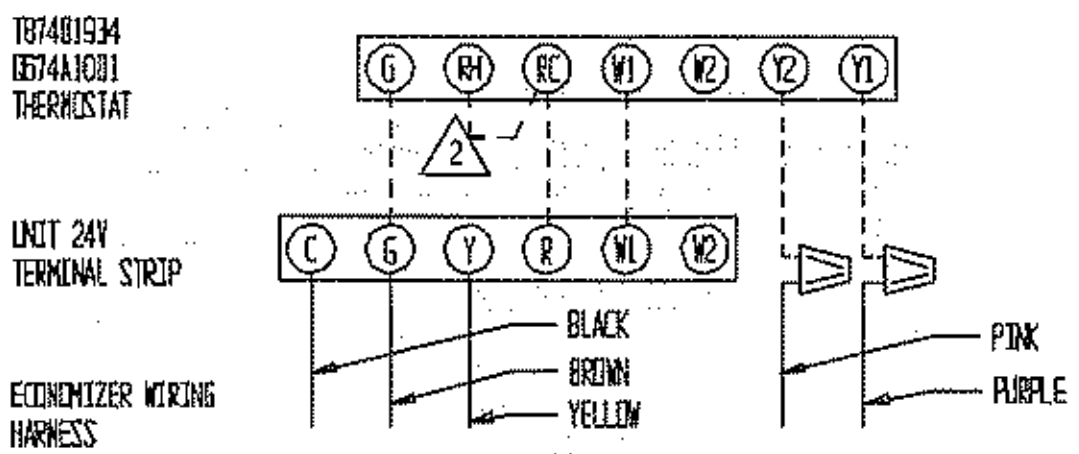

M19-503

IMPORTANT INSTALLER NOTE

For improved start up performance, wash the indoor coil with a dishwasher detergent.

SERVICE HINTS

1. Caution owner to maintain clean air filters at all times. Also not to needlessly close off supply and return air registers. This reduces air flow through the system which shortens equipment service life as well as increasing operation costs.
2. The unit is equipped with a high pressure cut out switch.
3. Check all power fuses or circuit breakers to be sure they are the correct rating.
4. Periodic cleaning of the outdoor coil to permit full and unrestricted airflow circulation is essential.

HIGH PRESSURE SWITCH

The WE121 models are supplied with a remote reset high pressure switch. If tripped, this pressure switch may be reset by turning the thermostat off then back on again.

SEQUENCE OF OPERATION

COOLING - Circuit R-Y makes at thermostat pulling in compressor contactor, starting the compressor and outdoor motor. The G (indoor motor) circuit is automatically completed on any call for cooling operation or can be energized by manual fan switch on subbase for constant air circulation. On a call for heating, circuit R-W1 make at the thermostat pulling in heat contact for the strip heat and blower operation.

COMPRESSOR CONTROL MODULE

The compressor control module is optional on the models covered by this manual. The compressor control is an anti-short cycle/lockout timer with high and low pressure switch monitoring and alarm relay output.

Adjustable Delay on Make and Break Timer

On initial power up or any time power is interrupted to the unit the *delay on make* period begins which will be 2 minutes plus 10% of the *delay on break* setting. When the *delay on make* is complete and the high

pressure switch (and low pressure switch if employed) is closed, the compressor contactor is energized. Upon shutdown the *delay on break* time starts and prevents restart until the *delay on break* and *delay on make* periods have expired.

During routine operation of the unit with no power interruptions the compressor will operate on demand with no delay.

High Pressure Switch and Lockout Sequence

If the high pressure switch opens, the compressor contactor will de-energize immediately. The lockout timer will go into a *soft lockout* and stay in *soft lockout* until the high pressure switch closes *and* the *delay on break* time has expired. If the high pressure switch opens again in this same operating cycle the unit will go into manual lockout condition and the alarm relay circuit will energize. Recycling the wall thermostat resets the manual lockout.

Low Pressure Switch, Bypass and Lockout Sequence (Optional)

If the low pressure switch opens for more than 120 seconds, the compressor contactor will de-energize and go into a *soft lockout*. Regardless the state of the low pressure switch, the contactor will reenergize after the *delay on make* time delay has expired. If the low pressure switch remains open, or opens again for longer than 120 seconds the unit will go into manual lockout condition and the alarm relay circuit will energize. Recycling the wall thermostat resets the manual lockout.

Alarm Relay Output

Alarm terminal is output connection for applications where alarm relay is employed. This terminal is powered whenever compressor is locked out due to HPC or LPC sequences as described.

NOTE: Both high and low pressure switch controls are inherently automatic reset devices. The high pressure switch and low pressure switch cut out and cut in settings are fixed by specific air conditioner or heat pump unit model. The lockout features, both soft and manual, are a function of the Compressor Control Module.

ADJUSTMENTS

Adjustable Delay on Make and Delay on Break Timer

The potentiometer is used to select Delay on Break time from 30 seconds to 5 minutes. Delay of Make (DOM) timing on power up and after power interruptions is equal to 2 minutes plus 10% of Delay of Break (DOB) setting:

0.5 minute (30 seconds) DOB = 123 second DOM

1.0 minute (60 seconds) DOB = 126 second DOM

2.0 minute (120 seconds) DOB = 132 second DOM

3.0 minute (180 seconds) DOB = 138 second DOM

4.0 minute (240 seconds) DOB = 144 second DOM

5.0 minute (300 seconds) DOB = 150 second DOM

During routine operation of the unit with no power interruptions the compressor will operate on demand with not delay.

Typical Settings for Dual Unit Installation:

Unit 1: DOB set at 2 minutes, and DOM is 132 seconds.

Unit 2: DOB set at 4 minutes, and DOM is 144 seconds.

PRESSURE SERVICE PORTS

Liquid and suction pressure service ports are installed on all units so that the system operating pressures can be observed. Pressure chart can be found later in the manual covering all models. It is imperative to match the correct pressure chart to the unit by model number.

TROUBLESHOOTING

FAN BLADE SETTING DIMENSIONS

Show in Figure 9 is the correct fan blade setting dimension for proper air delivery across the outdoor coil.

Any service work requiring removal or adjustment in the fan and/or motor area will require that the dimension below be checked and blade adjusted in or out on the motor shaft accordingly.

FIGURE 9
FAN BLADE SETTING DIMENSION

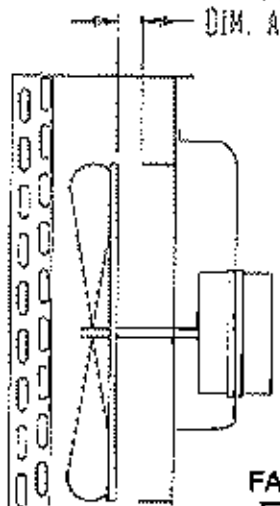

TABLE 5
FAN BLADE DIMENSION

Model	Dimension A
WE121	1/2"

REFRIGERANT CHARGE

The correct system R-407C charge is shown on the unit rating plate. Optimum unit performance will occur with a refrigerant charge resulting in a suction line temperature (6" from compressor) as shown in Table 6.

TABLE 6
SUCTION LINE TEMPERATURE

Model	Rated Airflow	95° OD Temperature	82° OD Temperature
WE121	400	59 - 61	69 - 71

The suction line temperatures in Table 6 are based upon 80° F dry bulb / 67° F wet bulb (50% R.H.) temperature and rated airflow across the evaporator during cooling cycle.

TABLE 7
INDOOR BLOWER PERFORMANCE
CFM @ 220V

E.S.P. in H ₂ O	WE121	
	220V	
	Dry	Wet
.0	450	430
.1	417	396
.2	378	368
.3	335	323
.4	280	258

TABLE 8
RATED CFM AND ESP
RECOMMENDED AIRFLOW RANGE

Model	Rated CFM*	Rated ESP*	Recommended Airflow Range
WE121	400	.10	450 - 350

* Rated CFM and ESP on high speed tap.

TABLE 9
MAXIMUM ESP OF OPERATION
ELECTRIC HEAT ONLY

Model	ESP
WE121-G00	.35
G02	.35
G03	.35

Values shown are for units equipped with STD 1" throwaway filters. Derate ESP by .15 for 2" pleated filters.

**TABLE 10
PRESSURE TABLE**

COOLING			Air Temperature Entering Outdoor Coil °F								
Model	Return Air Temperature	Pressure	75°	80°	85°	90°	95°	100°	105°	110°	115°
WE121	75° DB	Low Side	66	69	73	76	79	82	86	90	93
	62° WB	High Side	189	207	224	244	263	284	305	328	351
	80° DB	Low Side	71	74	78	81	85	88	92	96	99
	67° WB	High Side	194	212	230	250	270	291	313	336	360
	85° DB	Low Side	73	77	81	84	88	91	95	99	102
	72° WB	High Side	201	219	238	259	279	301	324	348	373

**TABLE 11
OPTIONAL FIELD INSTALLED ACCESSORIES**

Model	Description	WE121
BOP-1A	Blank Off Plate	X
BFAD-1	Barometric Fresh Air Damper	X
EFM-1	Economizer with Exhaust	X
CMA-6	Low Ambient Control	X
CMA-20	LPC + TDR + LAC	X

NOTICE

The refrigeration system in this unit is charged with refrigerant R-407C

SERVICE PROCEDURE AND CONSIDERATIONS

Refrigerant R-407C is a blend of three refrigerants, HFC-32/HFC-125/HFC134A. Unlike pure fluids and azeotropes, blends boil and condense at varying temperatures for a given pressure. The range over which the temperature varies is referred to as temperature glide. R-407C has moderately high temperature glide between about 9° F and 13° F (5 to 7.2

Celsius) depending upon pressure.

When dealing with blends, pressure temperature tables are presented in an unconventional manner. Two temperatures are listed for the same pressure—the liquid temperature and the vapor temperature.

When a pressure reading is taken from the suction line or discharge line it is converted to temperature from the "Vapor Temperature" column on the pressure temperature chart.

When a pressure reading is taken at the liquid line it is converted to temperature from the "Liquid Temperature" column on the pressure temperature chart.

All Bard "WE" models have a pressure tap in the suction line and the liquid line.

See Pressure Temperature Table 10 on page 16.

CHARGING

When charging a system with R-407C only the liquid phase is to be used to ensure proper refrigerant composition and system performance.

When charging the system into the suction side, care must be exercised to avoid damage to the compressor. Because the refrigerant leaving the refrigerant cylinder must be in liquid phase, it is suggested that a sight glass be connected between the charging hose and the suction service port. This will permit you to adjust the cylinder hand valve so that liquid can leave the cylinder while allowing vapor to enter the compressor.

The proper refrigerant amount is shown on the unit rating plate.

LEAKS

If a significant leak develops in the system and a noticeable change in the system performance occurs, remove the remaining refrigerant with proper refrigerant recovery methods, repair the leak with proper industry practice and methods, and then, after evacuation, recharge the system with new refrigerant. Again, charge only with liquid refrigerant to ensure that the proper composition is in the system.



CAUTION

Leak checking should never be done with a mixture of R-407C and air. Leak checking can be performed safely with a mixture of R-407C and nitrogen. Make sure the leak detector is capable of detecting R-407C before using.

NOTICE:

When opening a system, care must be taken to minimize the system exposure to atmosphere. Exposure for more than five minutes could shorten the life of the system. The compressor in this system contains Polyol Ester (POE) oil. POE's are very hygroscopic. They absorb moisture from the atmosphere at a much faster rate than mineral oils used in R-22 systems.

This system has a factory-installed filter drier in the liquid line. It is highly recommended that the filter drier be replaced when the system has been open. Make sure the replacement filter drier is suitable and approved for use with R-407C.

Before recharging the system, a vacuum of 250 microns or less must be achieved.

TABLE 12
R-407C SATURATED VAPOR/LIQUID
TEMPERATURE/PRESSURE CHART

Pressure (PSIG)	Liquid Temp. (F°)	Vapor Temp. (F°)	Pressure (PSIG)	Liquid Temp. (F°)	Vapor Temp. (F°)
20	-10.7	1.5	150	74.8	84.9
22	-8.2	4.0	155	76.8	86.8
24	-5.7	6.4	160	78.7	88.7
26	-3.4	8.7	165	80.6	90.5
28	-1.1	11.0	170	82.5	92.3
30	1.1	13.1	175	84.3	94.0
32	3.2	15.2	180	86.1	95.8
34	5.3	17.2	185	87.8	97.5
36	7.3	19.2	190	89.6	99.1
38	9.2	21.0	195	91.3	100.7
40	11.1	22.9	200	92.9	102.3
42	12.9	24.7	205	94.6	103.9
44	14.7	26.4	210	96.2	105.4
46	16.4	28.1	215	97.7	107.0
48	18.1	29.7	220	99.3	108.4
50	19.7	31.3	225	100.8	109.9
52	21.3	32.9	230	102.3	111.4
54	22.9	34.4	235	103.8	112.8
56	24.4	35.9	240	105.3	114.2
58	25.9	37.4	245	106.7	115.6
60	27.4	38.8	250	108.2	116.9
62	28.8	40.2	255	109.6	118.2
64	30.2	41.6	260	111.0	119.6
66	31.6	43.0	265	112.3	120.9
68	33.0	44.3	270	113.7	122.1
70	34.3	45.6	275	115.0	123.4
72	35.6	46.9	280	116.3	124.7
74	36.9	48.1	285	117.6	125.9
76	38.2	49.3	290	118.9	127.1
78	39.4	50.6	295	120.2	128.3
80	40.6	51.8	300	121.4	129.5
82	41.9	52.9	305	122.7	130.7
84	43.0	54.1	310	123.9	131.8
86	44.2	55.2	315	125.1	133.0
88	45.4	56.3	320	126.3	134.1
90	46.5	57.4	325	127.5	135.2
92	47.6	58.5	330	128.7	136.3
94	48.7	59.6	335	129.8	137.4
96	49.8	60.7	340	131.0	138.5
98	50.9	61.7	345	132.1	139.6
100	51.9	62.7	350	133.2	140.6
105	54.5	65.2	355	134.3	141.7
110	57.0	67.7	360	135.4	142.7
115	59.5	70.0	365	136.5	143.7
120	61.8	72.3	370	137.6	144.7
125	64.1	74.8	375	138.7	145.7
130	66.4	76.7	380	139.8	146.7
135	68.5	78.8	385	140.8	147.7
140	70.7	80.9	390	141.8	148.7
145	72.8	82.9	395	142.9	149.6

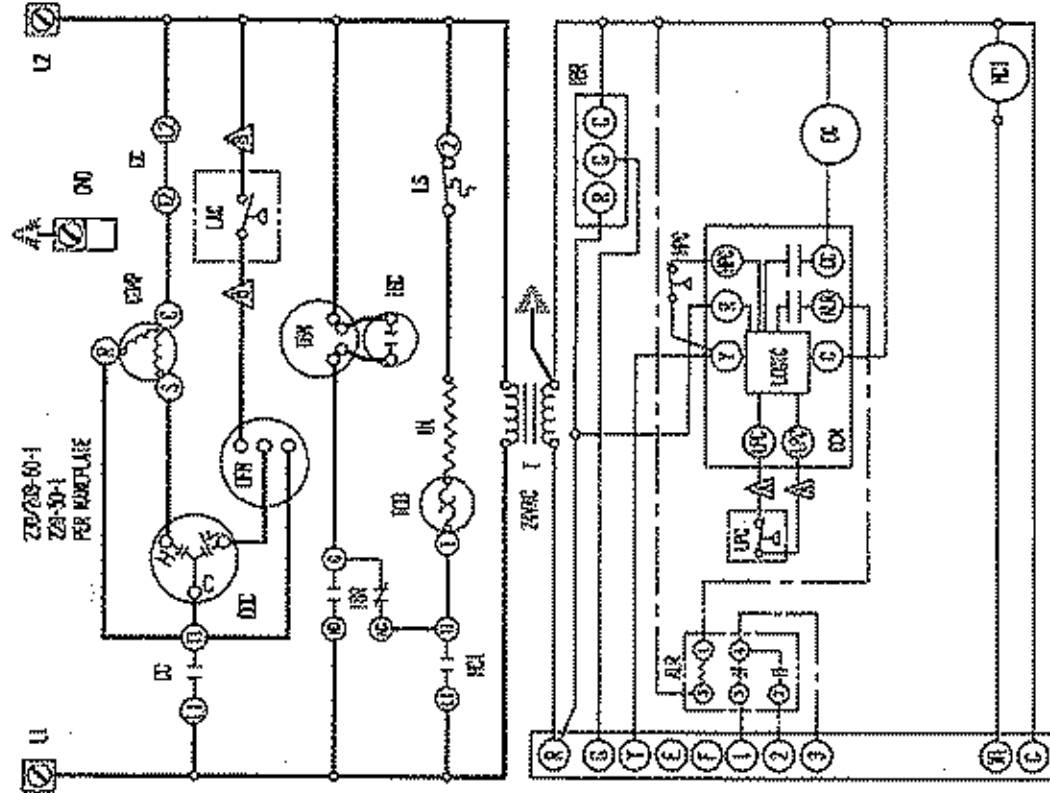
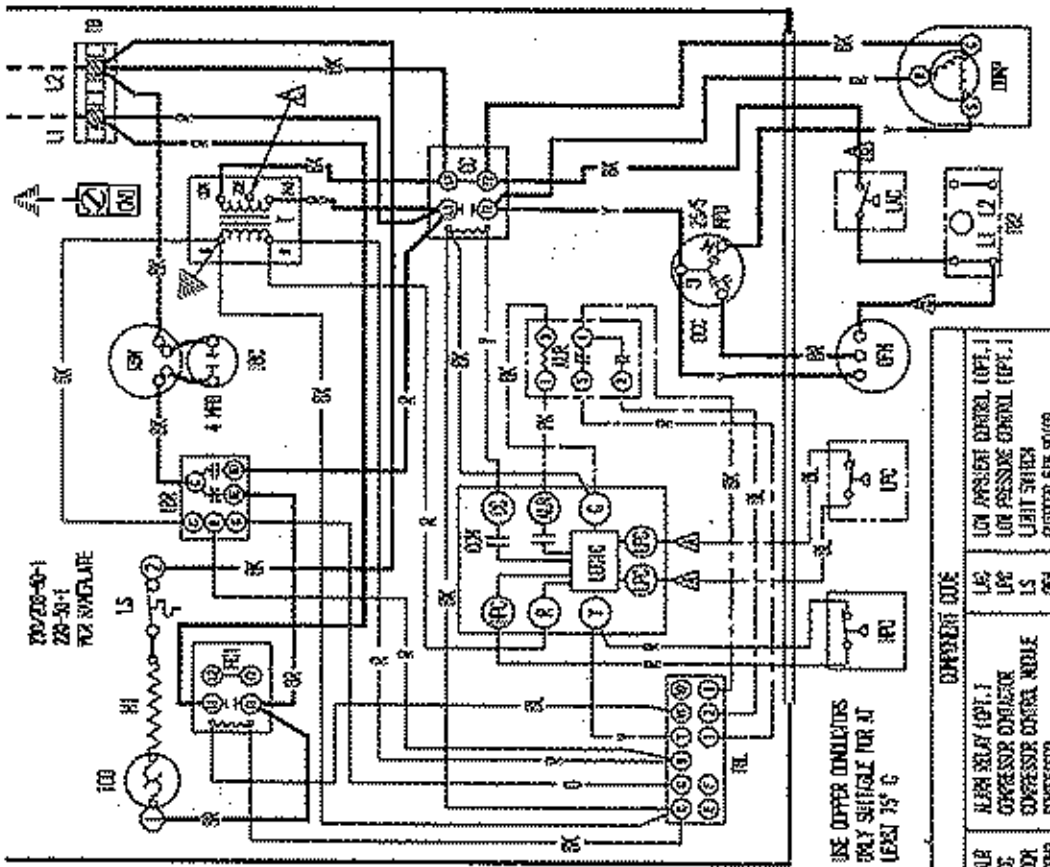

OTHER CODE	
LR	LEAK RELAY (OPT.)
CR	COMPRESSOR OVERHEAT
DR	COMPRESSOR OVERHAUL
OR	COMPRESSOR
UR	REF. ON DEFROSTER
YR	EQUIPMENT GROUND
ER	HEAT STRIP #1
FR	HEATER OVERHEAT #1
TR	HEAT PRESSURE CONTROL
BR	WATER FLOW OVERHEAT
DR	WATER FLOW OVERHEAT
DR	WATER FLOW RELAY
LR	LOW PRESSURE CONTROL (OPT.)
LR	LOW PRESSURE CONTROL (OPT.)
LS	LIGHT SWITCH
SR	ORDER AIR FLOW
TR	TRANSFORMER
TR	TEMPERATURE SENSITIVE
TR	TEMPERATURE SENSITIVE
TR	TEMPERATURE SENSITIVE
TR	TEMPERATURE SENSITIVE
TR	TEMPERATURE SENSITIVE

WIRE RED WIRE TO 257 TAP FOR 257Y OPERATION													
WIRE VALUE	FACTORY NO.	FIELD	SPECIAL	OTHER CODE								BARB WFG. CO.	
WIRE VALUE	FACTORY NO.	FIELD	SPECIAL	BLK	BRN	RED	ORNG	GRN	BLU	WHI	PNK	UNDEF	4095-114 E
WIRE VALUE	FACTORY NO.	FIELD	SPECIAL	0	1	2	3	4	5	6	7	8	4095-114 E

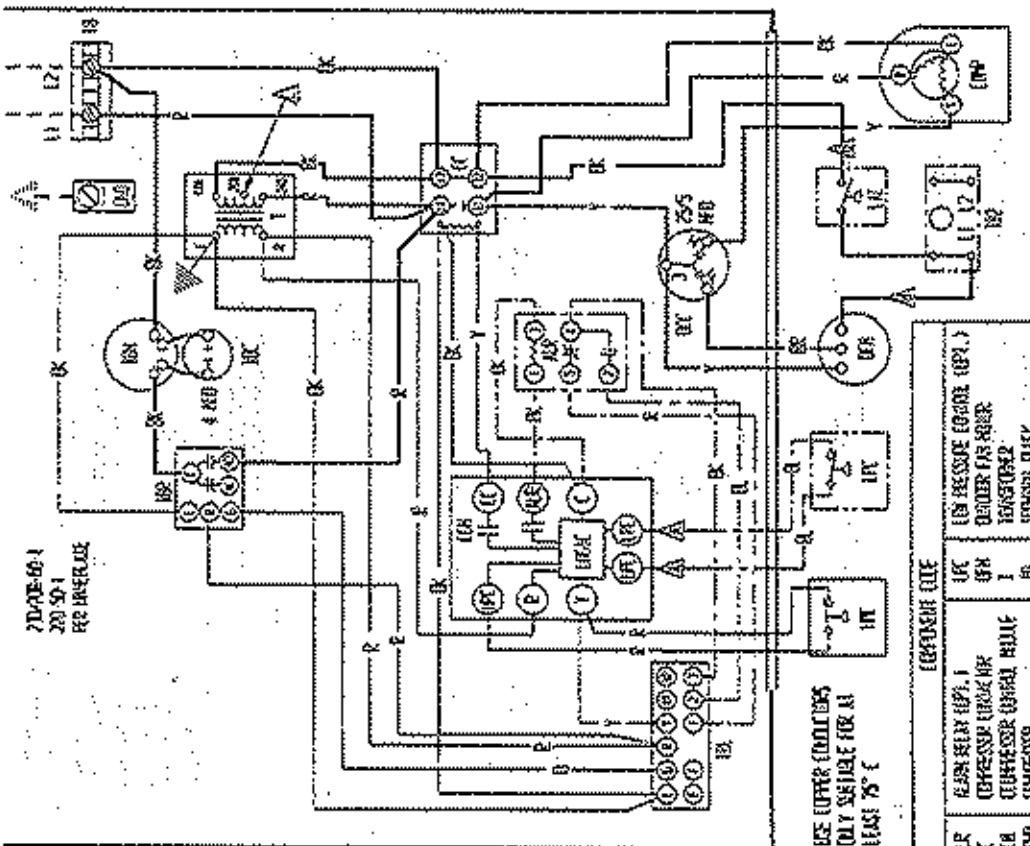
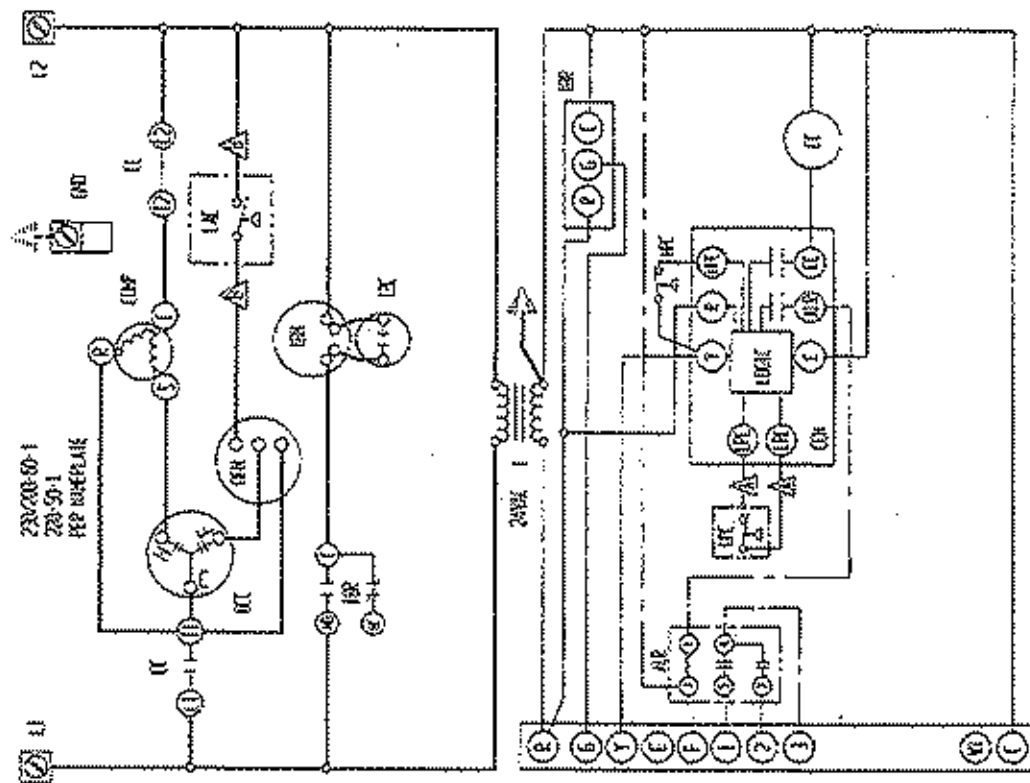

WIRE COLOR CODE

BR	BLK	BLU	GRN	WH	RED	OR	YEL	PK	GRY	LT	DR	TR	BLK	BLU	GRN	WH	RED	OR	YEL	PK	GRY	LT	DR	TR
BR	BLK	BLU	GRN	WH	RED	OR	YEL	PK	GRY	LT	DR	TR	BLK	BLU	GRN	WH	RED	OR	YEL	PK	GRY	LT	DR	TR

WIRE COLOR CODE

BR	BLK	BLU	GRN	WH	RED	OR	YEL	PK	GRY	LT	DR	TR	BLK	BLU	GRN	WH	RED	OR	YEL	PK	GRY	LT	DR	TR
BR	BLK	BLU	GRN	WH	RED	OR	YEL	PK	GRY	LT	DR	TR	BLK	BLU	GRN	WH	RED	OR	YEL	PK	GRY	LT	DR	TR

WIRE COLOR CODE

BR	BLK	BLU	GRN	WH	RED	OR	YEL	PK	GRY	LT	DR	TR	BLK	BLU	GRN	WH	RED	OR	YEL	PK	GRY	LT	DR	TR
BR	BLK	BLU	GRN	WH	RED	OR	YEL	PK	GRY	LT	DR	TR	BLK	BLU	GRN	WH	RED	OR	YEL	PK	GRY	LT	DR	TR

SEE UPPER CONTROL PANEL ONLY WIRING FOR ALL CASE 75 C

WIRE COLOR CODE

BR	BLK	BLU	GRN	WH	RED	OR	YEL	PK	GRY	LT	DR	TR	BLK	BLU	GRN	WH	RED	OR	YEL	PK	GRY	LT	DR	TR
BR	BLK	BLU	GRN	WH	RED	OR	YEL	PK	GRY	LT	DR	TR	BLK	BLU	GRN	WH	RED	OR	YEL	PK	GRY	LT	DR	TR

WIRE COLOR CODE

BR	BLK	BLU	GRN	WH	RED	OR	YEL	PK	GRY	LT	DR	TR	BLK	BLU	GRN	WH	RED	OR	YEL	PK	GRY	LT	DR	TR
BR	BLK	BLU	GRN	WH	RED	OR	YEL	PK	GRY	LT	DR	TR	BLK	BLU	GRN	WH	RED	OR	YEL	PK	GRY	LT	DR	TR

WIRE COLOR CODE

BR	BLK	BLU	GRN	WH	RED	OR	YEL	PK	GRY	LT	DR	TR	BLK	BLU	GRN	WH	RED	OR	YEL	PK	GRY	LT	DR	TR
BR	BLK	BLU	GRN	WH	RED	OR	YEL	PK	GRY	LT	DR	TR	BLK	BLU	GRN	WH	RED	OR	YEL	PK	GRY	LT	DR	TR

WIRE COLOR CODE

BR	BLK	BLU	GRN	WH	RED	OR	YEL	PK	GRY	LT	DR	TR	BLK	BLU	GRN	WH	RED	OR	YEL	PK	GRY	LT	DR	TR
BR	BLK	BLU	GRN	WH	RED	OR	YEL	PK	GRY	LT	DR	TR	BLK	BLU	GRN	WH	RED	OR	YEL	PK	GRY	LT	DR	TR