

---

# INSTALLATION INSTRUCTIONS

# WALL MOUNTED PACKAGED AIR CONDITIONER

Models: WA611, WA701,  
WA721

---

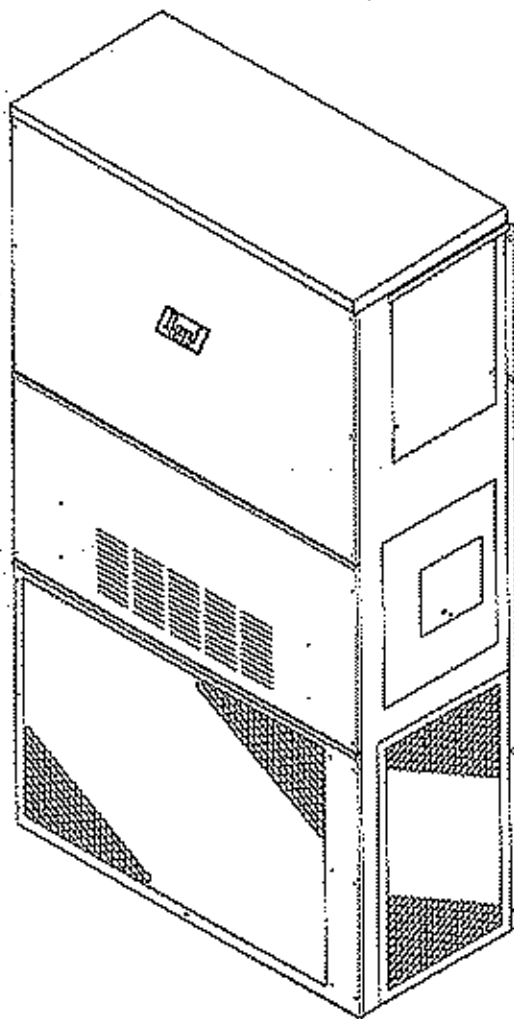

MIS-901



CLIMATE CONTROL SOLUTIONS

Bard Manufacturing Company  
Bryan, Ohio 43506  
*Since 1914...Moving ahead, just as planned.*

Manual No.: 2100-266L  
Supersedes: 2100-266K  
File: Volume III, Tab 16  
Date: 05-13-02

## Getting Other Information and Publications

---

These publications can help you install the air conditioner or heat pump. You can usually find these at your local library or purchase them directly from the publisher. Be sure to consult current edition of each standard.

National Electrical Code ..... ANSI/NFPA 70

Standard for the Installation ..... ANSI/NFPA 90A  
of Air Conditioning and  
Ventilating Systems

Standard for Warm Air ..... ANSI/NFPA 90B  
Heating and Air  
Conditioning Systems

Load Calculation for ..... ACCA Manual J or  
Residential Winter and ..... Manual N  
Summer Air Conditioning

Low Pressure, Low Velocity ..... ACCA Manual D or  
Duct System Design for Winter ..... Manual Q  
and Summer Air Conditioning

### FOR MORE INFORMATION, CONTACT THESE PUBLISHERS:

**ACCA** Air Conditioning Contractors of America  
1712 New Hampshire Ave. N.W.  
Washington, DC 20009  
Telephone: (202) 483-9370  
Fax: (202) 234-4721

**ANSI** American National Standards Institute  
11 West Street, 13th Floor  
New York, NY 10036  
Telephone: (212) 642-4900  
Fax: (212) 302-1286

**ASHRAE** American Society of Heating Refrigerating,  
and Air Conditioning Engineers, Inc.  
1791 Tullie Circle, N.E.  
Atlanta, GA 30329-2305  
Telephone: (404) 636-8400  
Fax: (404) 321-5478

**NFPA** National Fire Protection Association  
Batterymarch Park  
P.O. Box 9101  
Quincy, MA 02269-9901  
Telephone: (800) 344-3555  
Fax: (617) 984-7057

---

Manufactured under the following U.S. patent numbers:

5,485,878; 5,301,744; 5,002,116; 4,924,934;  
4,876,520; 4,825,938

# Getting Other Information and Publications

These publications can help you install the air conditioner or heat pump. You can usually find these at your local library or purchase them directly from the publisher. Be sure to consult current edition of each standard.

National Electrical Code ..... ANSI/NFPA 70

Standard for the Installation ..... ANSI/NFPA 90A  
of Air Conditioning and  
Ventilating Systems

Standard for Warm Air ..... ANSI/NFPA 90B  
Heating and Air  
Conditioning Systems

Load Calculation for ..... ACCA Manual J or  
Residential Winter and ..... Manual N  
Summer Air Conditioning

Low Pressure, Low Velocity ..... ACCA Manual D or  
Duct System Design for Winter ..... Manual Q  
and Summer Air Conditioning

## FOR MORE INFORMATION, CONTACT THESE PUBLISHERS:

**ACCA** Air Conditioning Contractors of America  
1712 New Hampshire Ave. N.W.  
Washington, DC 20009  
Telephone: (202) 483-9370  
Fax: (202) 234-4721

**ANSI** American National Standards Institute  
11 West Street, 13th Floor  
New York, NY 10036  
Telephone: (212) 642-4900  
Fax: (212) 302-1286

**ASHRAE** American Society of Heating Refrigerating,  
and Air Conditioning Engineers, Inc.  
1791 Tullie Circle, N.E.  
Atlanta, GA 30329-2305  
Telephone: (404) 636-8400  
Fax: (404) 321-5478

**NFPA** National Fire Protection Association  
Battymarch Park  
P.O. Box 9101  
Quincy, MA 02269-9901  
Telephone: (800) 344-3555  
Fax: (617) 984-7057

Manufactured under the following U.S. patent numbers:

5,485,878; 5,301,744; 5,002,116; 4,924,934;  
4,875,520; 4,825,936

# WALL MOUNT GENERAL INFORMATION

## AIR CONDITIONER WALL MOUNT MODEL NOMENCLATURE

**MODEL NUMBER**  
**WA 70 1 - B 09 X X X X X J**

**CAPACITY**  
 81 - 5 Ton  
 70 - 6 Ton  
 72 - 6 Ton

**REVISION**

**VOLTS & PHASE**  
 A - 230/208-1  
 B - 230/208/60-3  
 C - 460/60-3

**KW**  
 00 - No KW  
 02 - No KW w/Circuit Breaker or Pull Disconnect  
 05 - 5 KW  
 09 - 9 KW  
 10 - 10 KW  
 15 - 15 KW  
 18 - 18 KW

**VENTILATION OPTIONS**  
 X - Barometric Fresh Air Damper (Standard)  
 B - Blank-off Plate  
 M - Motorized Fresh Air Damper  
 V - Commercial Room Ventilator - Motorized with Exhaust  
 E - Economizer (Internal) - Fully Modulating with Exhaust  
 R - Energy Recovery Ventilator - with Exhaust

**COIL OPTIONS**  
 X - Standard  
 1 - Phenolic Coated Evaporator  
 2 - Phenolic Coated Condenser  
 3 - Phenolic Coated Evaporator and Condenser

**COLOR OPTIONS**  
 X - Beige (Standard)  
 1 - White

**FILTER OPTIONS**  
 X - One Inch Throwaway (Standard)  
 W - One Inch Washable  
 P - Two Inch Pleated

**CONTROL MODULES**  
 J - Standard on all Models

**OUTLET OPTIONS**  
 X - Front (Standard)

**NOTE:** For 0KW and circuit breakers (230/208 V) or pull disconnects (460 V) applications, insert 02 in the KW field of model number.

**TABLE 1  
 ELECTRIC HEAT TABLE**

MODELS	WA611-A				WA611-B				WA611-C	
	240V-1		208V-1		240V-3		208V-3		460V-3	
	KW	AMPS	BTUH	AMPS	BTUH	AMPS	BTUH	AMPS	BTUH	AMPS
5.0	20.8	18,400	18.1	14,100	---	---	---	---	---	---
8.0	33.3	28,600	28.8	21,800	---	---	---	---	---	---
9.0	---	---	---	---	21.7	31,900	18.7	24,350	10.8	32,000
10.0	41.6	35,450	38.2	28,900	---	---	---	---	---	---

MODELS	WA701-A				WA701-B WA721-B				WA701-C	
	240V-1		208V-1		240V-3		208V-3		460V-3	
	KW	AMPS	BTUH	AMPS	BTUH	AMPS	BTUH	AMPS	BTUH	AMPS
5.0	20.8	17,050	18.1	12,800	---	---	---	---	---	---
9.0	---	---	---	---	21.7	30,600	18.7	23,030	10.8	30,700
10.0	41.6	34,130	38.2	28,600	---	---	---	---	---	---
15.0	62.5	51,200	54.1	38,400	38.2	51,200	31.2	38,400	17.3	47,800
18.0	---	---	---	---	43.3	61,430	37.5	48,100	---	---
20.0	83.2	68,260	72.1	51,200	---	---	---	---	---	---



**TABLE 3  
ELECTRICAL SPECIFICATIONS**

MODELS	Rated	No. of Power Circuits	SINGLE CIRCUIT				DUAL CIRCUIT							
			①	②	③	④	①	②	③	④				
			Minimum Circuit Ampacity	Maximum Over Current Protection	Field Wire Size	Ground Wire Size	Minimum Circuit Ampacity	Maximum Over Current Protection	Field Wire Size	Ground Wire Size				
WA611-A00,A0Z -A05 -A08 -A10	200/208-1	1	43	60	8	10	NA	NA	NA	NA	NA	NA	NA	NA
			43	60	8	10	NA	NA	NA	NA	NA	NA	NA	NA
			47	60	8	10	NA	NA	NA	NA	NA	NA	NA	NA
			58	60	8	10	NA	NA	NA	NA	NA	NA	NA	NA
WA611-B00,B0Z -B09	230/208-3	1	29	45	8	10	NA	NA	NA	NA	NA	NA	NA	
			33	45	8	10	NA	NA	NA	NA	NA	NA	NA	
WA611-C00,C0Z -C09	460-3	1	15	20	12	12	NA	NA	NA	NA	NA	NA	NA	
			17	20	12	12	NA	NA	NA	NA	NA	NA	NA	
WA701-A00,A0Z -A05 -A10 -A15 -A20	200/208-1	1	48	60	8	10	NA	NA	NA	NA	NA	NA	NA	
			48	60	8	10	NA	NA	NA	NA	NA	NA	NA	
		1	59	6	10	NA	NA	NA	NA	NA	NA	NA		
		1 or 2	85	4	8	59	26	59	30	10	10	10	10	
		1 or 2	110	2	6	59	52	60	60	6	6	10	10	
WA701-B00,B0Z -B09 -B15 -B18	230/208-3	1	36	50	8	10	NA	NA	NA	NA	NA	NA	NA	
			36	50	8	10	NA	NA	NA	NA	NA	NA	NA	
			52	60	6	10	NA	NA	NA	NA	NA	NA	NA	
			60	60	6	10	NA	NA	NA	NA	NA	NA	NA	
WA701-C00,C0Z -C09 -C15	460-3	1	17	25	12	12	NA	NA	NA	NA	NA	NA	NA	
			17	25	12	12	NA	NA	NA	NA	NA	NA	NA	
			28	30	10	10	NA	NA	NA	NA	NA	NA	NA	
WA721-B00,B0Z -B09 -B15 -B18	230/208-0	1	36	50	8	10	NA	NA	NA	NA	NA	NA	NA	
			36	50	8	10	NA	NA	NA	NA	NA	NA	NA	
			52	60	6	10	NA	NA	NA	NA	NA	NA	NA	
			60	60	6	10	NA	NA	NA	NA	NA	NA	NA	

① Maximum size of the time delay fuse or HACR type circuit breaker for protection of field wiring conductors.  
 ② Based on 75°C copper wire. All wiring must conform to the National Electric Code (NEC) and all local codes.  
 ③ These "Minimum Circuit Ampacity" values are to be used for sizing the field power conductors. Refer to the National Electric Code (latest version), Article 310 for power conductor sizing. **CAUTION:** When more than one field power conductor circuit is run through one conduit, the conductors must be derated. Pay special attention to Note \* of Table 310 regarding Ampacity Adjustment Factors when more than 3 conductors are in a raceway.

## SHIPPING DAMAGE

Upon receipt of equipment, the carton should be checked for external signs of shipping damage. If damage is found, the receiving party must contact the last carrier immediately, preferably in writing, requesting inspection by the carrier's agent.

## GENERAL

The equipment covered in this manual is to be installed by trained, experienced service and installation technicians.

The refrigerant system is completely assembled and charged. All internal wiring is complete.

The unit is designed for use with or without duct work. Flanges are provided for attaching the supply and return ducts.

These instructions explain the recommended method to install the air cooled self-contained unit and the electrical wiring connections to the unit.

These instructions and any instructions packaged with any separate equipment required to make up the entire air conditioning system should be carefully read before beginning the installation. Note particularly "Starting Procedure" and any tags and/or labels attached to the equipment.

While these instructions are intended as a general recommended guide, they do not supersede any national and/or local codes in any way. Authorities having jurisdiction should be consulted before the installation is made. See Page 1 for information on codes and standards.

Size of unit for a proposed installation should be based on heat loss calculation made according to methods of Air Conditioning Contractors of America (ACCA). The air duct should be installed in accordance with the Standards of the National Fire Protection Association for the Installation of Air Conditioning and Ventilating Systems of Other Than Residence Type, NFPA No. 90A, and Residence Type Warm Air Heating and Air Conditioning Systems, NFPA No. 90B. Where local regulations are at a variance with instructions, installer should adhere to local codes.

## DUCT WORK

All duct work, supply and return, must be properly sized for the design air flow requirement of the equipment. Air Conditioning Contractors of America (ACCA) is an excellent guide to proper sizing. All duct work or portions thereof not in the conditioned space should be properly insulated in order to both conserve energy and prevent condensation or moisture damage.

Refer to Table 9 for maximum static pressure available for duct design.

Design the duct work according to methods given by the Air Conditioning Contractors of America (ACCA). When duct runs through unheated spaces, it should be insulated with a minimum of 1 inch of insulation. Use insulation with a vapor barrier on the outside of the insulation. Flexible joints should be used to connect the duct work to the equipment in order to keep the noise transmission to a minimum.

A 1/4 inch clearance to combustible material for the first three feet of duct attached to the outlet air frame is required. See Wall Mounting Instructions and Figures 4 and 5 for further details.

Ducts through the walls must be insulated and all joints taped or sealed to prevent air or moisture entering the wall cavity.

## CAUTION

Some installations may not require any return air duct. A metallic return air grille is required with installations not requiring a return air duct. The spacing between louvers on the grille shall not be larger than 5/8 inches.

Any grille that meets the 5/8 inch louver criteria, may be used. It is recommended that Bard Return Air Grille Kit RG-2 thru RG-5 or RFG-2 thru RFG-5 be installed when no return duct is used. Contact distributor or factory for ordering information. If using a return air filter grille, filters must be of sufficient size to allow a maximum velocity of 400 fpm.

*NOTE: If no return air duct is used, applicable installation codes may limit this cabinet to installation only in a single story structure.*

## FILTERS

A 1 inch throwaway filter is supplied with each unit. The filter slides into position making it easy to service. This filter can be serviced from the outside by removing the service door. A 1 inch washable filter and 2 inch pleated filter are also available as optional accessories. The internal filter brackets are adjustable to accommodate the 2 inch filter by bending down the tabs to allow spacing for the 2 inch filters.

## FRESH AIR INTAKE

All units are built with fresh air inlet slots punched in the service panel.

If the unit is equipped with the fresh air damper assembly, the assembly is shipped already attached to the unit. The damper blade is locked in the closed position to allow the damper to operate, the maximum and minimum blade position stops must be installed.

See Figure 2.

All capacity, efficiency and cost of operation information as required for Department of Energy "Energyguide" Fact Sheets is based upon the fresh air blank-off plate in place and is recommended for maximum energy efficiency.

The blank-off plate is available upon request from the factory and is installed in place of the fresh air damper shipped with each unit.

## CONDENSATE DRAIN

A plastic drain hose extends from the drain pan at the top of the unit down to the unit base. There are openings in the unit base for the drain hose to pass through. In the event the drain hose is connected to a drain system of some type, it must be an open or vented type system to assure proper drainage.

FIGURE 2  
BLOWER DAMPER ASSEMBLY

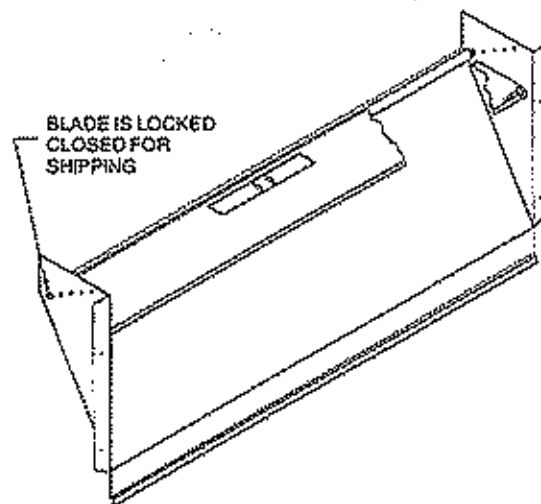

MIS-038



# INSTALLATION INSTRUCTIONS

## WALL MOUNTING INFORMATION

1. Two holes, for the supply and return air openings, must be cut through the wall as shown in Figure 3.
2. On wood-frame walls, the wall construction must be strong and rigid enough to carry the weight of the unit without transmitting any unit vibration. See Figures 4 and 5.

### **WARNING**

Fire hazard can result if 1/4 inch clearance to combustible materials for supply air duct is not maintained. See Figure 3.

3. Concrete block walls must be thoroughly inspected to insure that they are capable of carrying the weight of the installing unit. See Figure 4.

## MOUNTING THE UNIT

1. These units are secured by wall mounting brackets which secure the unit to the outside wall surface at both sides. A bottom mounting bracket is provided for ease of installation.
2. The unit itself is suitable for "0" inch clearance, but the supply air duct flange and the first 3 feet of supply air duct require a minimum of 1/4 inch clearance to combustible material. If a combustible wall, use a minimum of 30-1/2" x 10-1/2" dimensions for sizing. However, it is generally recommended that a 1 inch clearance is used for ease of installation and maintaining the required clearance to combustible material. The supply air opening would then be 32" x 12". See Figures 3, 4 and 7 for details.

### **WARNING**

Failure to provide the 1/4 inch clearance between the supply duct and a combustible surface for the first 3 feet of duct can result in fire.

3. Locate and mark lag bolt locations and bottom mounting bracket location. See Figure 4.

4. Mount bottom mounting bracket.
5. Hook top rain flashing under back bend of top. Top rain flashing is shipped secured to the right side of the back.
6. Position unit in opening and secure with 5/16 lag bolts; use 7/8 inch diameter flat washers on the lag bolts.
7. Secure rain flashing to wall and caulk across entire length of top. See Figure 3.
8. For additional mounting rigidity, the return air and supply air frames or collars can be drilled and screwed or welded to the structural wall itself (depending upon wall construction). Be sure to observe required clearance if combustible wall.
9. On side by side installations, maintain a minimum of 20 inches clearance on right side to allow access to heat strips and control panel and to allow proper airflow to the outdoor coil. Additional clearance may be required to meet local or national codes.

## TYPICAL INSTALLATIONS

See Figure 6 for common ways to install the wall-mount unit.

## WIRING — MAIN POWER

Refer to the unit rating plate for wire sizing information and maximum fuse or "HACR" type circuit breaker size. Each outdoor unit is marked with a "Minimum Circuit Ampacity". This means that the field wiring used must be sized to carry that amount of current. Depending on the installed KW of electric heat, there may be two field power circuits required. If this is the case, the unit serial plate will so indicate. All models are suitable only for connection with copper wire. Each unit and/or wiring diagram will be marked "Use Copper Conductors Only". These instructions *must be* adhered to. Refer to the National Electrical Code (NEC) for complete current carrying capacity data on the various insulation grades of wiring material. All wiring must conform to NEC and all local codes.

The electrical data lists fuse and wire sizes (75°C copper) for all models, including the most commonly used heater sizes. Also shown are the number of field power circuits required for the various models with heaters.

The unit rating plate lists a "Maximum Time Delay Relay Fuse" or "HACR" type circuit breaker that is to be used with the equipment. The correct size must be used for proper circuit protection and also to assure that there will be no nuisance tripping due to the momentary high starting current of the compressor motor.

The disconnect access door on this unit may be locked to prevent unauthorized access to the disconnect. To

convert for the locking capability, bend the tab located in the bottom left hand corner of the disconnect opening under the disconnect access panel straight out. This tab will now line up with the slot in the door. When shut, a padlock may be placed through the hole in the tab preventing entry.

See Start-up section for information on three phase scroll compressor start-ups.

**FIGURE 3  
MOUNTING INSTRUCTIONS**

*NOTE: It is recommended that a bead of silicone caulking be placed behind the side mounting flanges and under the top flashing at the time of installation.*

	A	B	C	D	E
REQUIRED DIMENSIONS TO MAINTAIN 1/4" MIN. CLEARANCE FROM CONDENSIBLE MEDIA	13 1/2"	10 1/2"	6 1/4"	5 3/16"	13 1/2"
REQUIRED DIMENSIONS TO MAINTAIN RECOMMENDED 1" CLEARANCE FROM CONDENSIBLE MEDIA	12"	12"	3 1/2"	9/16"	24"

SEE WITH BEAD OF CAULKING AROUND ENTIRE PERIMETER OF TOP.

TOP

RAIN FLASHING SUPPLY

FOAM AIR SEAL

WALL STRUCTURE

1/4" CLEARANCE ON ALL FOUR SIDES OF SUPPLY AIR DUCT IS REQUIRED FROM CONDENSIBLE MEDIA

HEATER ACCESS PANEL

SUPPLY AIR DUCT

REFUR AIR DUCT

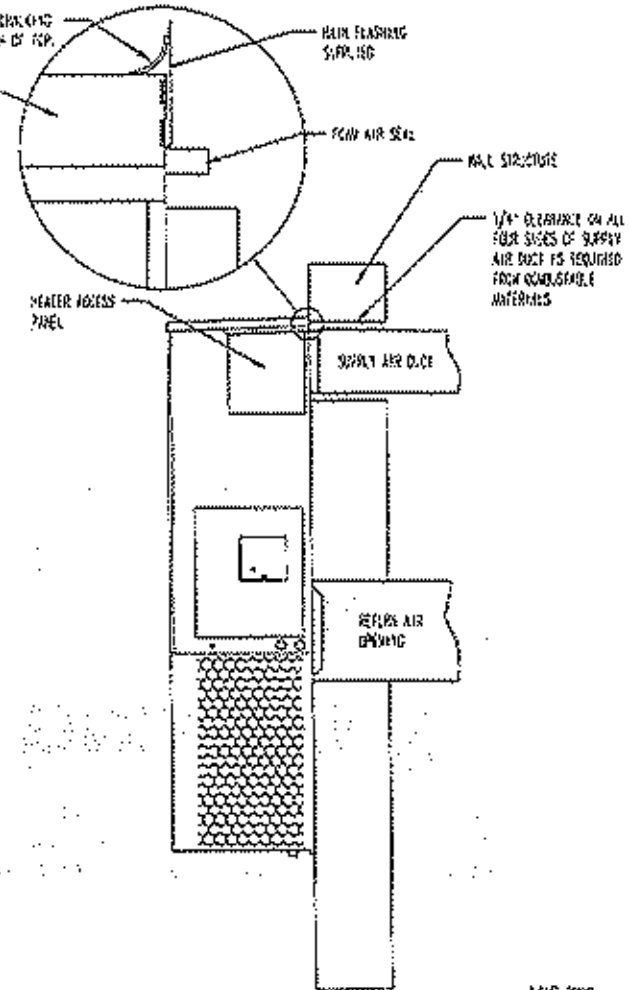
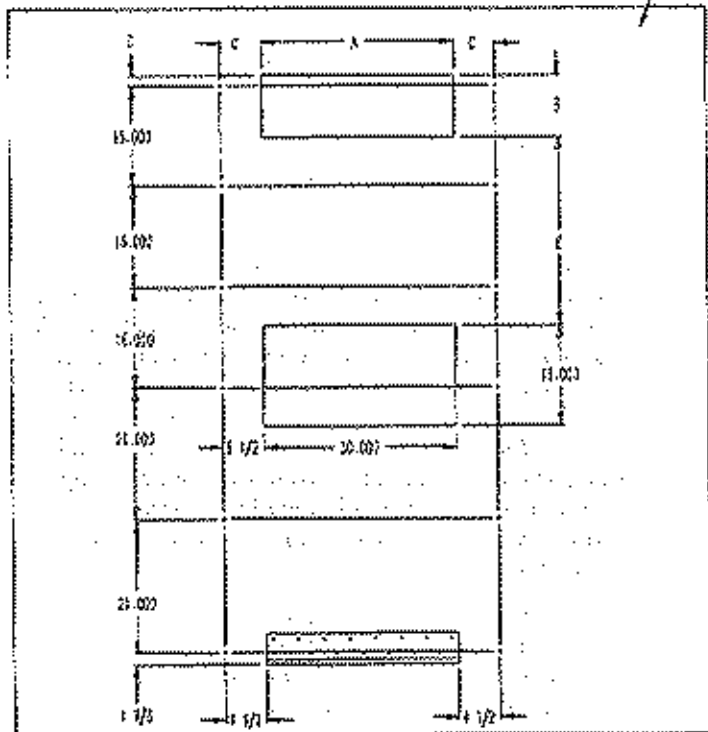

MIS-796

## WIRING — LOW VOLTAGE WIRING

230/208V, 1 phase and 3 phase equipment dual primary voltage transformers. All equipment leaves the factory wired on 240V tap. For 208V operation, reconnect from 240V to 208V tap. The acceptable operating voltage range for the 240 and 208V taps are shown in Table 4 below.

**TABLE 4  
OPERATING VOLTAGE RANGE**

TAP	RANGE
240V	253 - 216
208V	220 - 187

*NOTE: The voltage should be measured at the field power connection point in the unit and while the unit is operating at full load (maximum amperage operating condition).*

Five (5) wires should be run from thermostat subbase to the 24V terminal board in the unit. A five conductor, 18 gauge copper, color-coded thermostat cable is recommended. The connection points are shown in Figure 8.

**TABLE 5  
THERMOSTAT WIRE SIZE**

Transformer VA	FLA	Wire Gauge	Maximum Distance In Feet
65	2.3	20 gauge	45
		18 gauge	60
		16 gauge	100
		14 gauge	160
		12 gauge	250

**TABLE 6  
WALL THERMOSTAT AND SUBBASE COMBINATIONS**

Thermostat	Subbase	Predominate Features
8403-002 T87F3111	8404-003 Q539A1220	1 stage heat, 1 stage cool System: heat-off-cool Fan: auto-on
8403-041 T8034C	---	1 stage heat, 1 stage cool System: heat-off-cool Fan: auto-on
8403-019 T874C1760	8404-012 Q674A1001	1 stage cool, 2 stage heat System: heat-auto-cool Fan: auto-on
8403-021 T874D1934	8404-012 Q674A1001	2 stage cool, 2 stage heat System: heat-auto-cool Fan: auto-on
8403-049 1F93-380	---	2 stage cool, 2 stage heat Electronic 7 day programming
8403-043 CM-200	---	1 stage heat, 1 stage cool System: heat-off-cool Fan: auto-on

### FIGURE 4 WALL-MOUNTING INSTRUCTIONS

SEE FIGURES — MOUNTING INSTRUCTIONS

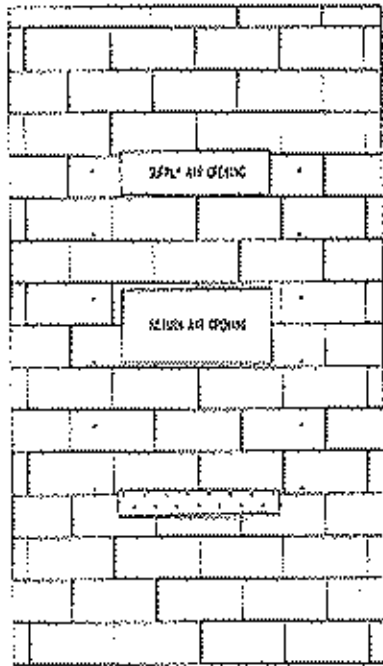

CONCRETE BLOCK WALL INSTALLATION

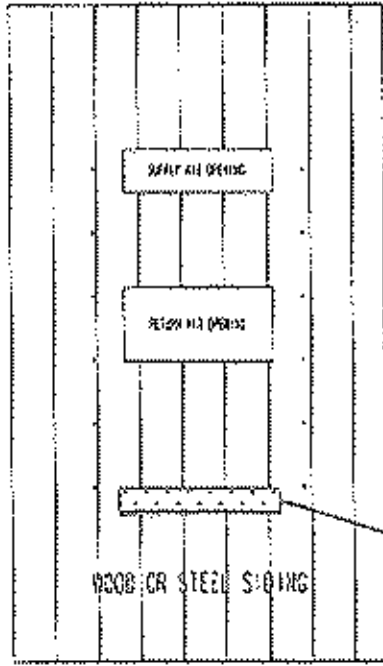

WOOD FRAME WALL INSTALLATION

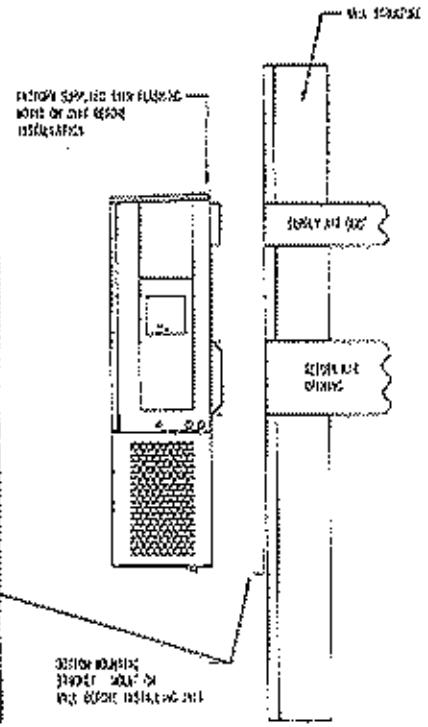

MIS-548

### FIGURE 5 WALL-MOUNTING INSTRUCTIONS

SEE UNIT DIMENSIONS, FIGURE 1,  
FOR ACTUAL DIMENSIONS

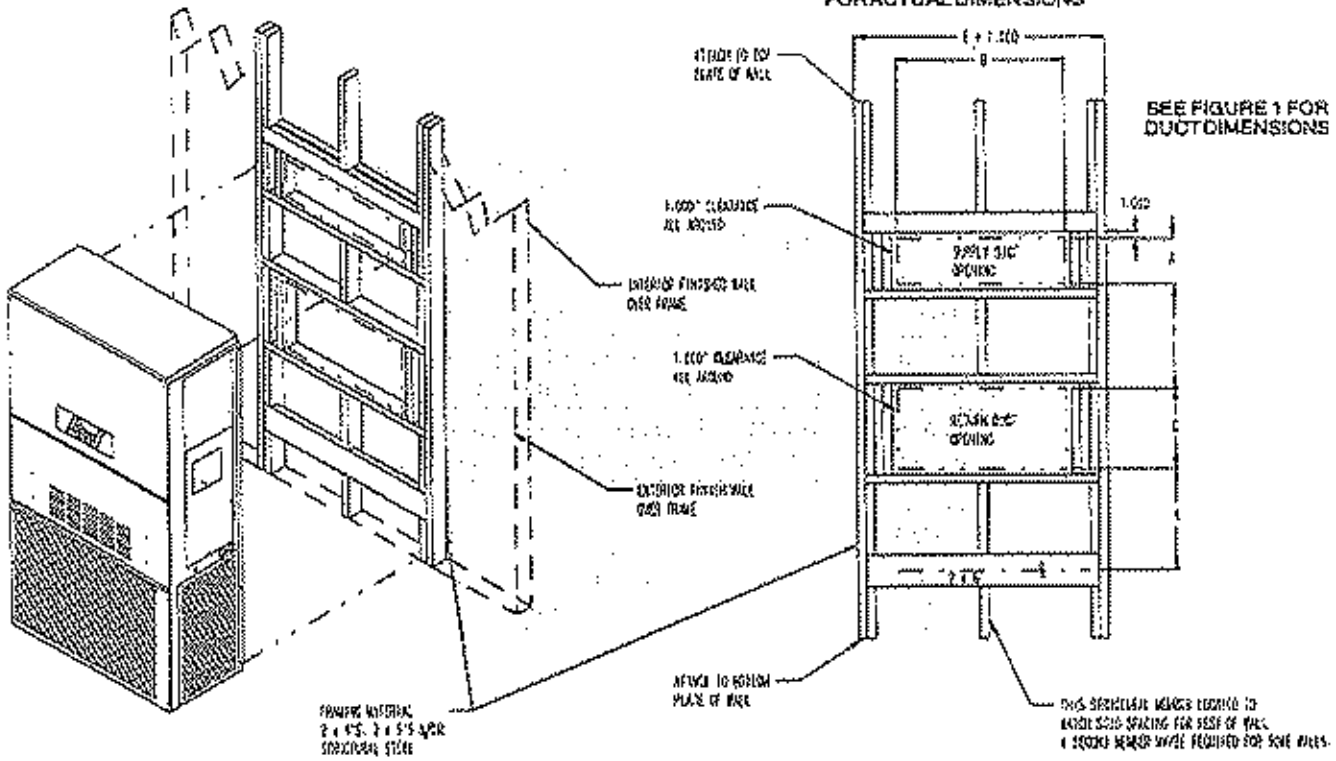

FRAMING MATERIAL  
2 x 4'S, 2 x 5'S AND  
STRUCTURAL STEEL

MIS-549

**FIGURE 6  
COMMON WALL-MOUNTING INSTALLATIONS**

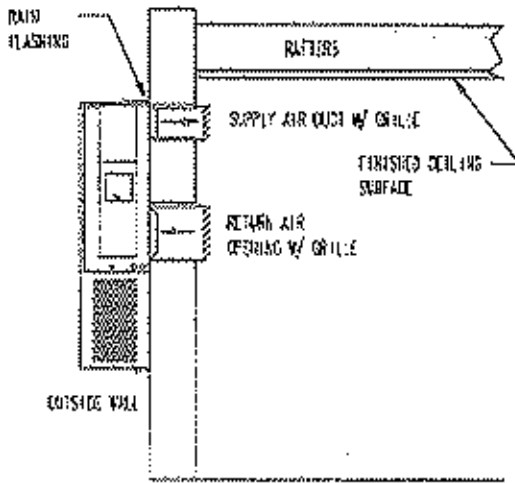

FREE AIR FLOW  
NO DUCT

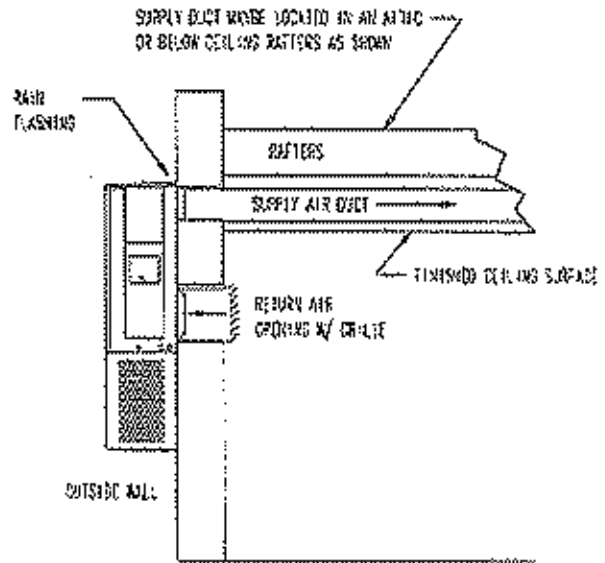

DUCTED SUPPLY  
RETURN AT UNIT

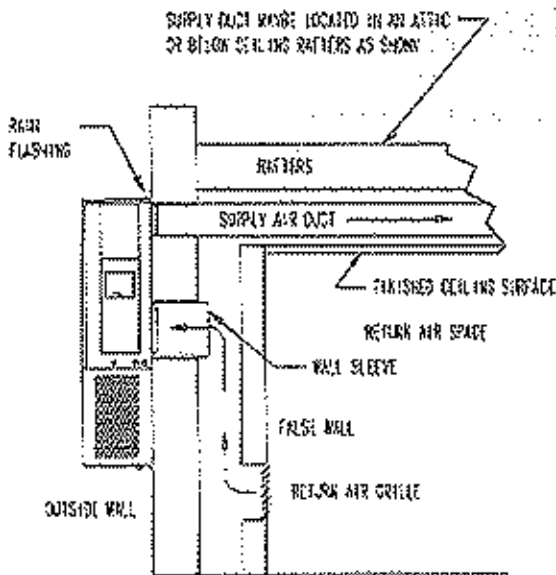

FALSE WALL INSTALLATION

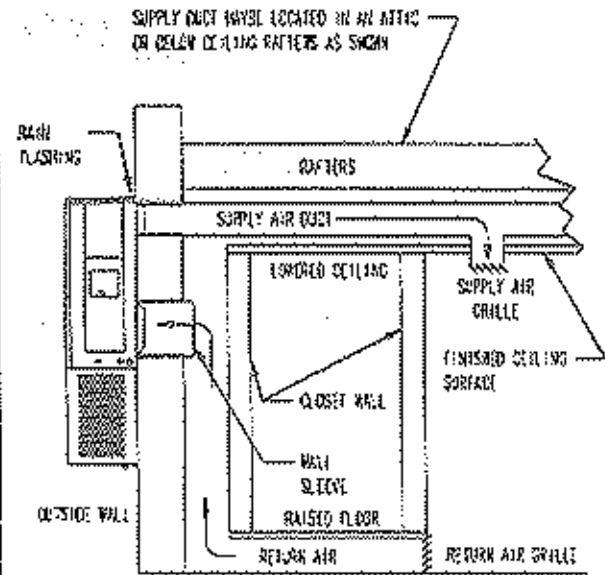

CLOSET INSTALLATION

143-550

**FIGURE 7  
ELECTRIC HEAT CLEARANCE**

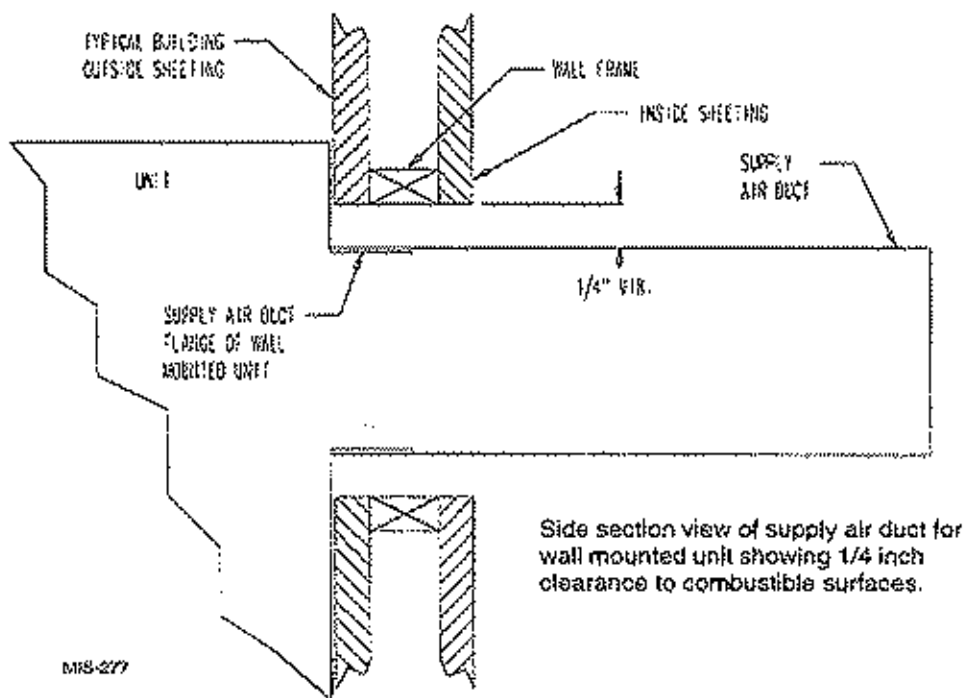

## **⚠ WARNING**

- A minimum of 1/4 inch clearance must be maintained between the supply air duct and combustible materials. This is required for the first 3 feet of ducting.
- It is important to insure that the 1/4 inch minimum spacing is maintained at all points.
- Failure to do this could result in overheating the combustible material and may result in fire.

**FIGURE 8  
LOW VOLTAGE WIRING**

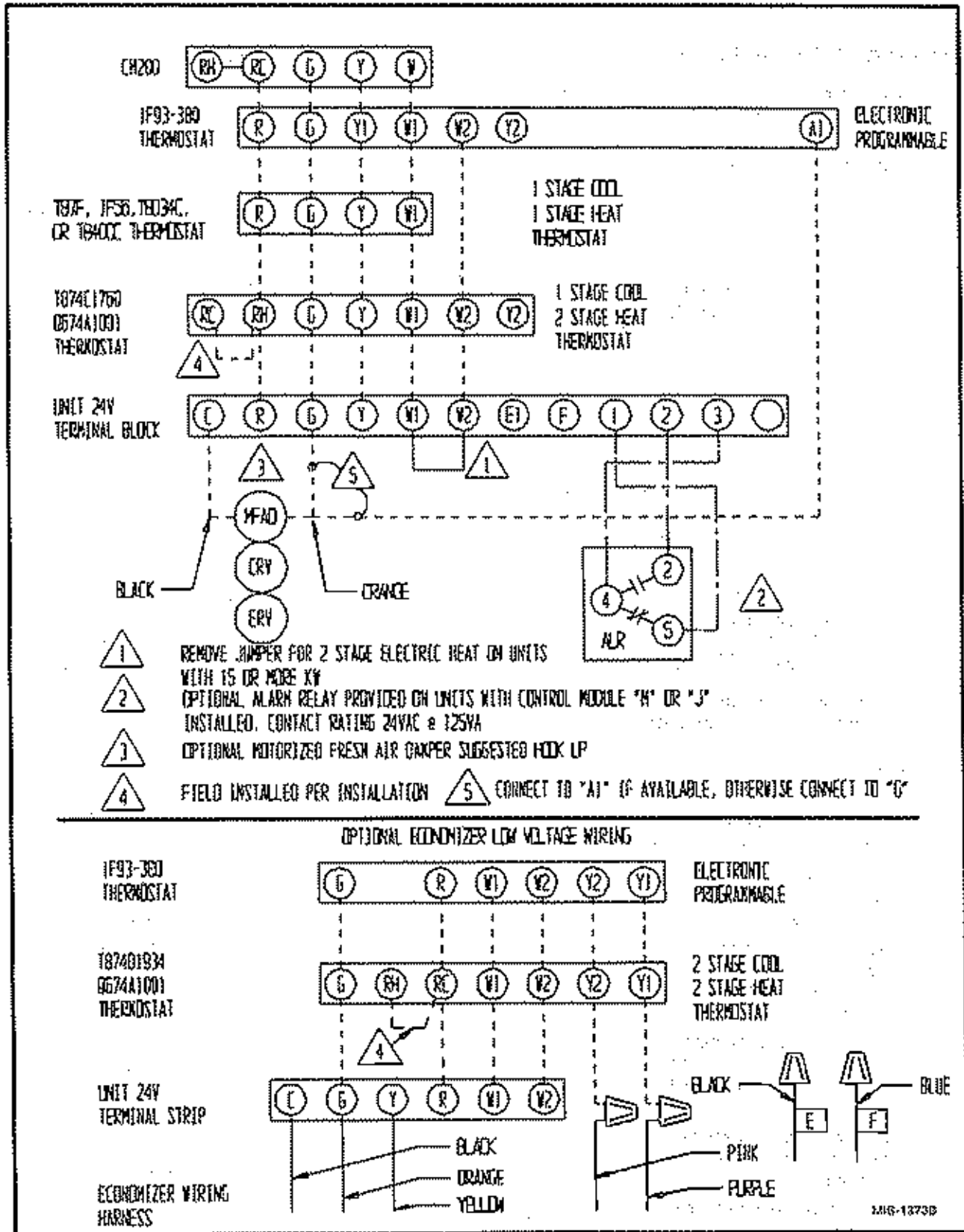

# START UP

## IMPORTANT INSTALLER NOTE

For improved start-up performance, wash the indoor coil with a dishwasher detergent.

## CRANKCASE HEATERS

WA611, WA701 and WA721 units are provided with compressor crankcase heat.

The WA611, WA701 and WA721 models have a band type heater located around the bottom of the compressor. This heater is controlled by the crankcase heater relay. The heater is only energized when the compressor is not running.

Some form of crankcase heat is essential to prevent liquid refrigerant from migrating to the compressor, causing oil pump out on compressor start-up and possible valve failure due to compressing a liquid.

The decal in Figure 9 is affixed to all WA611, WA701 and WA721 units detailing start-up procedure. This is very important. *Please read carefully.*

**FIGURE 9  
START-UP LABEL**

### IMPORTANT

These procedures must be followed at initial start-up and at any time power has been removed for 12 hours or longer.

To prevent compressor damage which may result from the presence of liquid refrigerant in the compressor crankcase.

1. Make certain the room thermostat is in the "off" position (the compressor is not to operate).
2. Apply power by closing the system disconnect switch. This energizes the compressor heater which evaporates the liquid refrigerant in the crankcase.
3. Allow 4 hours or 60 minutes per pound of refrigerant in the system as noted on the unit rating plate, whichever is greater.
4. After properly elapsed time, the thermostat may be set to operate the compressor.
5. Except as required for safety while servicing - **Do not open system disconnect switch.**

7961-061

## HIGH PRESSURE SWITCH

The WA611, WA701 and WA721 models are supplied with a remote reset high pressure switch. If tripped, this pressure switch may be reset by turning the thermostat off then back on again.

## THREE PHASE SCROLL COMPRESSOR START UP INFORMATION

Scroll compressors, like several other types of compressors, will only compress in one rotational direction. Direction of rotation is not an issue with single phase compressors since they will always start and run in the proper direction.

However, three phase compressors will rotate in either direction depending upon phasing of the power. Since there is a 50-50 chance of connecting power in such a way as to cause rotation in the reverse direction, verification of proper rotation must be made. All three phase units incorporate a phase monitor to ensure proper field wiring. See the "Phase Monitor" section later in this manual.

Verification of *proper rotation* must be made any time a compressor is change or rewired. If improper rotation is corrected at this time there will be no negative impact on the durability of the compressor. However, reverse operation for over one hour may have a negative impact on the bearing due to oil pump out.

*NOTE: If compressor is allowed to run in reverse rotation for several minutes, the compressor's internal protector will trip.*

All three phase ZR3 compressors are wired identically internally. As a result, once the correct phasing is determined for a specific system or installation, connecting properly phased power leads to the same Fusite terminal should maintain proper rotation direction.

Verification of proper rotation direction is made by observing that suction pressure drops and discharge pressure rises when the compressor is energized. Reverse rotation also results in an elevated sound level over that with correct rotations, as well as, substantially reduced current draw compared to tabulated values.

The direction of rotation of the compressor may be changed by reversing any two line connections to the unit.



## SERVICE HINTS

1. Caution homeowner to maintain clean air filters at all times. Also, not to needlessly close off supply and return air registers. This reduces air flow through the system, which shortens equipment service life as well as increasing operating costs.
2. Check all power fuses or circuit breakers to be sure they are the correct rating.
3. Periodic cleaning of the outdoor coil to permit full and unrestricted airflow circulation is essential.

## SEQUENCE OF OPERATION

**COOLING** – Circuit R-Y makes at thermostat pulling in compressor contactor, starting the compressor and outdoor motor. The G (indoor motor) circuit is automatically completed on any call for cooling operation or can be energized by manual fan switch on subbase for constant air circulation. On all 208/230 volt models, when G circuit is de-energized the indoor blower motor will continue to run for one minute. On a call for heating, circuit R-W1 make at the thermostat pulling in heat contact for the strip heat and blower operation. On a call for second stage heat, R-W2 makes bringing on second heat contactor, if so equipped.

## COMPRESSOR CONTROL MODULE

The compressor control module is standard on the models covered by this manual. The compressor control is an anti-short cycle/lockout timer with high and low pressure switch monitoring and alarm relay output.

### Adjustable Delay On Make And Break Timer

On initial power up or any time power is interrupted to the unit the *delay on make* period begins which will be 2 minutes plus 10% of the *delay on break* setting. When the delay on make is complete and the high pressure switch (and low pressure switch if employed) is closed, the compressor contactor is energized. Upon shutdown the delay or break timer starts and prevents restart until the delay on break and delay on make periods have expired.

During routine operation of the unit with no power interruptions the compressor will operate on demand with no delay.

### High Pressure Switch and Lockout Sequence

If the high pressure switch opens, the compressor contactor will de-energize immediately. The lockout timer will go into a *soft lockout* and stay in soft lockout until the high pressure switch closes and the delay on break time has expired. If the high pressure switch opens again in this same operating cycle the unit will go into *manual lockout* condition and the alarm relay circuit will energize. Recycling the wall thermostat resets the manual lockout.

### Low Pressure Switch, Bypass, and Lockout Sequence

If the low pressure switch opens for more than 120 seconds, the compressor contactor will de-energize and go into a soft lockout. Regardless the state of the low pressure switch, the contactor will reenergize after the delay on make time delay has expired. If the low pressure switch remains open, or opens again for longer than 120 seconds the unit will go into manual lockout condition and the alarm relay circuit will energize. Recycling the wall thermostat resets the manual lockout.

### Alarm Relay Output

Alarm terminal is output connection for applications where alarm relay is employed. This terminal is powered whenever compressor is locked out due to HPC or LPC sequences as described.

*NOTE: Both high and low pressure switch controls are inherently automatic reset devices. The high pressure switch and low pressure switch cut out and cut in settings are fixed by specific air conditioner or heat pump unit model. The lockout features, both soft and manual, are a function of the Compressor Control Module.*

## ADJUSTMENTS

### Adjustable Delay on Make and Delay on Break Timer

The potentiometer is used to select Delay on Break time from 30 seconds to 5 minutes. Delay on Make (DOM) timing on power-up and after power interruptions is equal to 2 minutes plus 10% of Delay on Break (DOB) setting:

- 0.5 minute (30 seconds) DOB = 123 second DOM
- 1.0 minute (60 seconds) DOB = 126 second DOM
- 2.0 minute (120 seconds) DOB = 132 second DOM
- 3.0 minute (180 seconds) DOB = 138 second DOM
- 4.0 minute (240 seconds) DOB = 144 second DOM
- 5.0 minute (300 seconds) DOB = 150 second DOM

During routine operation of the unit with no power interruptions the compressor will operate on demand with no delay.

### Typical Settings for Dual Unit Installation:

Unit 1: DOB set at 2 minutes, and DOM is 132 seconds

Unit 2: DOB set at 4 minutes, and DOM is 144 seconds

## PHASE MONITOR

All units with three phase scroll compressors are equipped with a 3 phase line monitor to prevent compressor damage due to phase reversal.

The phase monitor in this unit is equipped with two LEDs. If the Y signal is present at the phase monitor and phases are correct the green LED will light.

If phases are reversed, the red fault LED will be lit and compressor operation is inhibited.

If a fault condition occurs, reverse two of the supply leads to the unit. Do not reverse any of the unit factory wires as damage may occur.

## PRESSURE SERVICE PORTS

High and low pressure service ports are installed on all units so that the system operating pressures can be observed. Pressure tables can be found later in the manual covering all models. It is imperative to match the correct pressure table to the unit by model number.

# TROUBLESHOOTING

## FAN BLADE SETTING DIMENSIONS

Shown in the drawing below are the correct fan blade setting dimensions for proper air delivery across the outdoor coil.

Any service work requiring removal or adjustment in the fan and/or motor area will require that the dimensions below be checked and blade adjusted in or out on the motor shaft accordingly.

FIGURE 10  
FAN BLADE SETTING

TABLE 7  
FAN BLADE DIMENSIONS

Model	Dimension A
WA611 WA701	1.25
WA721	.75

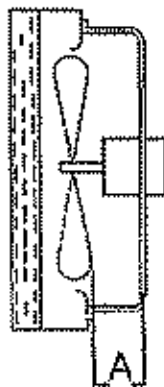

## REMOVAL OF FAN SHROUD

1. Disconnect all power to unit.
2. Remove the screws holding both grills - one on each side of unit - and remove grills.
3. Remove screws holding fan shroud to condenser and bottom - (9) screws.
4. Unwire condenser fan motor.
5. Slide complete motor, fan blade, and shroud assembly out the left side of the unit.

6. Service motor/fan as needed.
7. Reverse steps to reinstall.

## REFRIGERANT CHARGE

The correct system R-22 charge is shown on the unit rating plate. Optimum unit performance will occur with a refrigerant charge resulting in a suction line temperature (6 inches from compressor) as shown in Table 8:

TABLE 8  
SUCTION LINE TEMPERATURES

Models	Rated Airflow	95 F OD Temp.	82 F OD Temp.
WA611	1,350	52 - 54	57 - 60
WA701	1,800	58 - 60	56 - 58
WA721	1,800	59 - 61	57 - 59

The suction line temperatures in Table 8 are based upon 80°F dry bulb / 67°F wet bulb (50 percent R.H.) temperature and rated airflow across the evaporator during cooling cycle.

TABLE 9  
CFM and ESP

Rated Model	① Rated CFM	① Rated ESP	Recommended Air Flow Range
WA611	1,350	.20	1,475 - 1,100
WA701	1,800	.20	2,000 - 1,375
WA721	1,800	.20	2,000 - 1,475

① Rated CFM and ESP on high speed tap.

TABLE 10  
INDOOR BLOWER PERFORMANCE - CFM AT 230 VOLTS

E.S.P. In H <sub>2</sub> O	WA611				WA701 WA721			
	High Speed		Medium Speed ①		High Speed		Low Speed	
	Dry Coil	Wet Coil	Dry Coil	Wet Coil	Dry Coil	Wet Coil	Dry Coil	Wet Coil
.0	1,700	1,575	1,425	1,375	2,200	2,000	1,600	1,450
.1	1,550	1,475	1,375	1,250	2,100	1,900	1,525	1,375
.2	1,400	1,350	1,250	1,100	2,000	1,800	—	—
.3	1,250	1,150	1,100	—	1,875	1,700	—	—
.4	—	—	—	—	1,775	1,600	—	—
.5	—	—	—	—	1,650	1,475	—	—

① This model has 3-speed motor, but low speed cannot be used.

**TABLE 11  
MAXIMUM ESP OF OPERATION  
ELECTRIC HEAT ONLY**

Model	WA611		WA701		WA721	
Speed KW	Medium Speed	High Speed	Low Speed	High Speed	Low Speed	High Speed
-A05	.30	.30	.50	.50	---	---
-A08	.30	.30	---	---	---	---
-A10	.30	.30	.50	.50	---	---
-A20	.30	.30	.40	.50	---	---
-B09	.30	.30	.50	.50	.50	.50
-B16	---	---	.50	.50	.50	.50
-B18	---	---	.50	.50	.50	.50
-C09	.30	.30	.50	.50	---	---
-C15	---	---	.50	.50	---	---

**TABLE 12  
COOLING PRESSURE -- (All temperatures °F)**

Model	Return Air Temp.	Pressure	75	80	85	90	95	100	105	110	115
WA611-A,-B,-C	75 DB 62 WB	Low Side	72	72	73	74	75	76	77	79	79
		High Side	237	237	240	247	256	269	286	304	327
	80 DB 67 WB	Low Side	77	77	78	79	80	81	82	84	85
		High Side	243	243	246	253	263	276	293	312	335
	85 DB 72 WB	Low Side	80	80	81	82	83	84	85	87	88
		High Side	252	252	255	262	272	286	303	323	347
WA701-A	75 DB 62 WB	Low Side	68	68	69	70	71	72	73	74	75
		High Side	215	228	242	256	272	289	305	324	343
	80 DB 67 WB	Low Side	73	73	74	75	76	77	78	79	80
		High Side	220	234	248	263	279	296	313	332	352
	85 DB 72 WB	Low Side	76	76	77	78	79	80	81	82	83
		High Side	228	242	257	272	289	306	324	344	364
WA701-B,-C	75 DB 62 WB	Low Side	62	63	64	65	66	67	68	69	70
		High Side	214	230	247	265	280	299	316	333	351
	80 DB 67 WB	Low Side	67	68	69	70	71	72	73	74	75
		High Side	220	236	254	271	287	306	324	342	360
	85 DB 72 WB	Low Side	72	73	74	75	76	77	78	79	80
		High Side	225	243	261	279	297	316	335	353	372
WA721	75 DB 62 WB	Low Side	63	64	65	66	67	68	69	70	71
		High Side	205	222	237	254	268	286	302	318	336
	80 DB 67 WB	Low Side	68	69	70	71	72	73	74	75	76
		High Side	211	227	244	261	275	294	310	327	345
	85 DB 72 WB	Low Side	73	74	75	76	77	78	79	80	81
		High Side	216	234	251	268	285	303	321	339	357

Low side pressure ± 2 psig  
High side pressure ± 5 psig

Tables are based upon rated CFM (airflow) across the evaporator coil. If there is any doubt as to correct operating charge being in the system, the charge should be removed, system evacuated and recharged to serial plate instruction.

**TABLE 13  
OPTIONAL ACCESSORIES**

MODEL	DESCRIPTION	WA611-A	WA611-B	WA611-C	WA701-A	WA701-B	WA701-C	WA721-B
EHWA05-A05	Heater Package				X			
EHWA10-A10	Heater Package				X			
EHWA15-A15	Heater Package				X			
EHWA20-A20	Heater Package				X			
EHWA60-B09	Heater Package					X		X
EHWA05-B15	Heater Package					X		X
EHWA05-B18	Heater Package					X		X
EHWA05A-C09	Heater Package			X			X	
EHWA05A-C15	Heater Package						X	
EHWA61-A05	Heater Package	X						
EHWA61-A10	Heater Package	X						
EHWA61-A08	Heater Package	X						
EHWA61-B09	Heater Package		X					
BOP-5	Blank Off Plate	X	X	X	X	X	X	X
BFAD-5	Barometric Fresh Air Damper	X	X	X	X	X	X	X
MFAD-5	Motorized Fresh Air Damper	X	X	X	X	X	X	X
CRV-5	Classroom Ventilator with Exhaust	X	X	X	X	X	X	X
EFM-5	Economizer with Exhaust	X	X		X	X	X	X
WERV-A5A	Energy Recovery Ventilator				X	X		X
WERV-C5A	Energy Recovery Ventilator			X			X	
WMPD-01C	Pull Disconnect Kit			X			X	

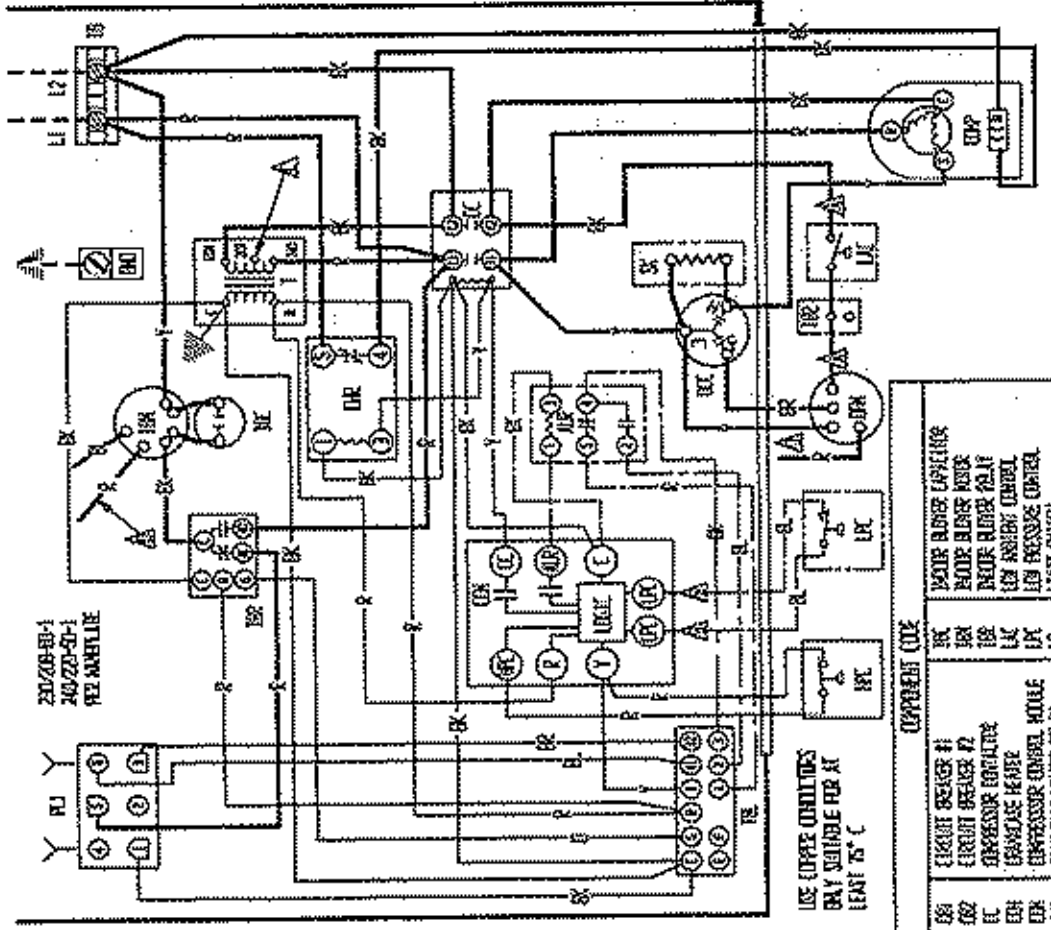
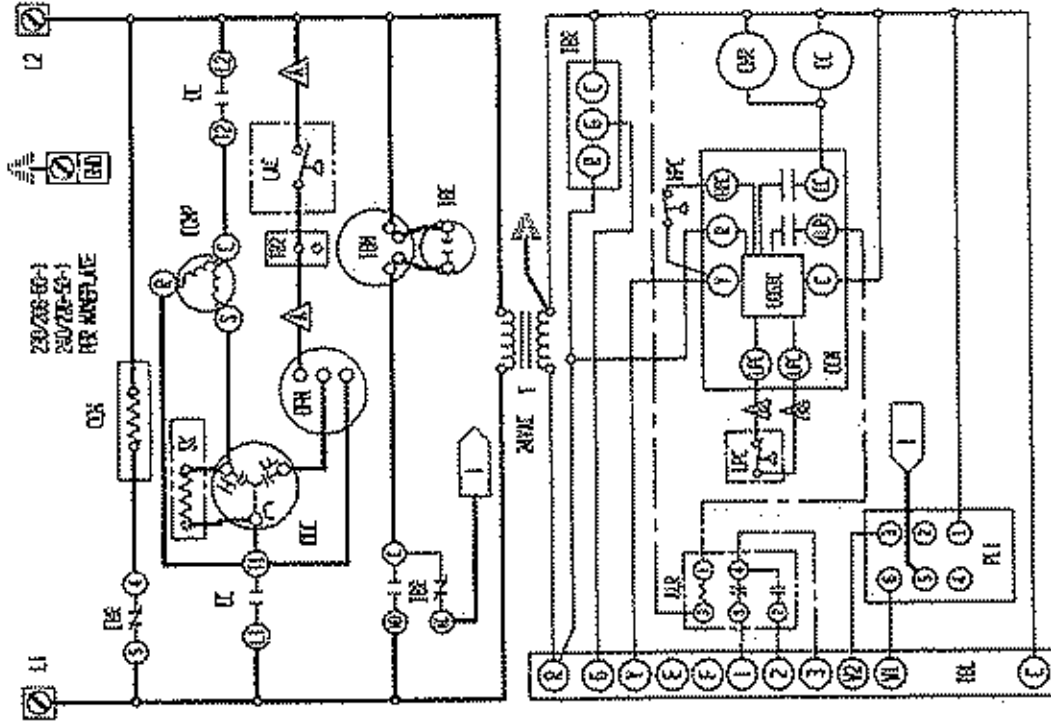

<p>240/208V-1P/1.5W FR AMPLIE</p>	<p>240/208V-1P/1.5W FR AMPLIE</p>	<p>240/208V-1P/1.5W FR AMPLIE</p>	<p>240/208V-1P/1.5W FR AMPLIE</p>
<p>11</p>	<p>12</p>	<p>13</p>	<p>14</p>
<p>15</p>	<p>16</p>	<p>17</p>	<p>18</p>
<p>19</p>	<p>20</p>	<p>21</p>	<p>22</p>
<p>23</p>	<p>24</p>	<p>25</p>	<p>26</p>
<p>27</p>	<p>28</p>	<p>29</p>	<p>30</p>
<p>31</p>	<p>32</p>	<p>33</p>	<p>34</p>
<p>35</p>	<p>36</p>	<p>37</p>	<p>38</p>
<p>39</p>	<p>40</p>	<p>41</p>	<p>42</p>
<p>43</p>	<p>44</p>	<p>45</p>	<p>46</p>
<p>47</p>	<p>48</p>	<p>49</p>	<p>50</p>
<p>51</p>	<p>52</p>	<p>53</p>	<p>54</p>
<p>55</p>	<p>56</p>	<p>57</p>	<p>58</p>
<p>59</p>	<p>60</p>	<p>61</p>	<p>62</p>
<p>63</p>	<p>64</p>	<p>65</p>	<p>66</p>
<p>67</p>	<p>68</p>	<p>69</p>	<p>70</p>
<p>71</p>	<p>72</p>	<p>73</p>	<p>74</p>
<p>75</p>	<p>76</p>	<p>77</p>	<p>78</p>
<p>79</p>	<p>80</p>	<p>81</p>	<p>82</p>
<p>83</p>	<p>84</p>	<p>85</p>	<p>86</p>
<p>87</p>	<p>88</p>	<p>89</p>	<p>90</p>
<p>91</p>	<p>92</p>	<p>93</p>	<p>94</p>
<p>95</p>	<p>96</p>	<p>97</p>	<p>98</p>
<p>99</p>	<p>100</p>	<p>101</p>	<p>102</p>
<p>103</p>	<p>104</p>	<p>105</p>	<p>106</p>
<p>107</p>	<p>108</p>	<p>109</p>	<p>110</p>
<p>111</p>	<p>112</p>	<p>113</p>	<p>114</p>
<p>115</p>	<p>116</p>	<p>117</p>	<p>118</p>
<p>119</p>	<p>120</p>	<p>121</p>	<p>122</p>
<p>123</p>	<p>124</p>	<p>125</p>	<p>126</p>
<p>127</p>	<p>128</p>	<p>129</p>	<p>130</p>
<p>131</p>	<p>132</p>	<p>133</p>	<p>134</p>
<p>135</p>	<p>136</p>	<p>137</p>	<p>138</p>
<p>139</p>	<p>140</p>	<p>141</p>	<p>142</p>
<p>143</p>	<p>144</p>	<p>145</p>	<p>146</p>
<p>147</p>	<p>148</p>	<p>149</p>	<p>150</p>
<p>151</p>	<p>152</p>	<p>153</p>	<p>154</p>
<p>155</p>	<p>156</p>	<p>157</p>	<p>158</p>
<p>159</p>	<p>160</p>	<p>161</p>	<p>162</p>
<p>163</p>	<p>164</p>	<p>165</p>	<p>166</p>
<p>167</p>	<p>168</p>	<p>169</p>	<p>170</p>
<p>171</p>	<p>172</p>	<p>173</p>	<p>174</p>
<p>175</p>	<p>176</p>	<p>177</p>	<p>178</p>
<p>179</p>	<p>180</p>	<p>181</p>	<p>182</p>
<p>183</p>	<p>184</p>	<p>185</p>	<p>186</p>
<p>187</p>	<p>188</p>	<p>189</p>	<p>190</p>
<p>191</p>	<p>192</p>	<p>193</p>	<p>194</p>
<p>195</p>	<p>196</p>	<p>197</p>	<p>198</p>
<p>199</p>	<p>200</p>	<p>201</p>	<p>202</p>
<p>203</p>	<p>204</p>	<p>205</p>	<p>206</p>
<p>207</p>	<p>208</p>	<p>209</p>	<p>210</p>
<p>211</p>	<p>212</p>	<p>213</p>	<p>214</p>
<p>215</p>	<p>216</p>	<p>217</p>	<p>218</p>
<p>219</p>	<p>220</p>	<p>221</p>	<p>222</p>
<p>223</p>	<p>224</p>	<p>225</p>	<p>226</p>
<p>227</p>	<p>228</p>	<p>229</p>	<p>230</p>
<p>231</p>	<p>232</p>	<p>233</p>	<p>234</p>
<p>235</p>	<p>236</p>	<p>237</p>	<p>238</p>
<p>239</p>	<p>240</p>	<p>241</p>	<p>242</p>
<p>243</p>	<p>244</p>	<p>245</p>	<p>246</p>
<p>247</p>	<p>248</p>	<p>249</p>	<p>250</p>
<p>251</p>	<p>252</p>	<p>253</p>	<p>254</p>
<p>255</p>	<p>256</p>	<p>257</p>	<p>258</p>
<p>259</p>	<p>260</p>	<p>261</p>	<p>262</p>
<p>263</p>	<p>264</p>	<p>265</p>	<p>266</p>
<p>267</p>	<p>268</p>	<p>269</p>	<p>270</p>
<p>271</p>	<p>272</p>	<p>273</p>	<p>274</p>
<p>275</p>	<p>276</p>	<p>277</p>	<p>278</p>
<p>279</p>	<p>280</p>	<p>281</p>	<p>282</p>
<p>283</p>	<p>284</p>	<p>285</p>	<p>286</p>
<p>287</p>	<p>288</p>	<p>289</p>	<p>290</p>
<p>291</p>	<p>292</p>	<p>293</p>	<p>294</p>
<p>295</p>	<p>296</p>	<p>297</p>	<p>298</p>
<p>299</p>	<p>300</p>	<p>301</p>	<p>302</p>
<p>303</p>	<p>304</p>	<p>305</p>	<p>306</p>
<p>307</p>	<p>308</p>	<p>309</p>	<p>310</p>
<p>311</p>	<p>312</p>	<p>313</p>	<p>314</p>
<p>315</p>	<p>316</p>	<p>317</p>	<p>318</p>
<p>319</p>	<p>320</p>	<p>321</p>	<p>322</p>
<p>323</p>	<p>324</p>	<p>325</p>	<p>326</p>
<p>327</p>	<p>328</p>	<p>329</p>	<p>330</p>
<p>331</p>	<p>332</p>	<p>333</p>	<p>334</p>
<p>335</p>	<p>336</p>	<p>337</p>	<p>338</p>
<p>339</p>	<p>340</p>	<p>341</p>	<p>342</p>
<p>343</p>	<p>344</p>	<p>345</p>	<p>346</p>
<p>347</p>	<p>348</p>	<p>349</p>	<p>350</p>
<p>351</p>	<p>352</p>	<p>353</p>	<p>354</p>
<p>355</p>	<p>356</p>	<p>357</p>	<p>358</p>
<p>359</p>	<p>360</p>	<p>361</p>	<p>362</p>
<p>363</p>	<p>364</p>	<p>365</p>	<p>366</p>
<p>367</p>	<p>368</p>	<p>369</p>	<p>370</p>
<p>371</p>	<p>372</p>	<p>373</p>	<p>374</p>
<p>375</p>	<p>376</p>	<p>377</p>	<p>378</p>
<p>379</p>	<p>380</p>	<p>381</p>	<p>382</p>
<p>383</p>	<p>384</p>	<p>385</p>	<p>386</p>
<p>387</p>	<p>388</p>	<p>389</p>	<p>390</p>
<p>391</p>	<p>392</p>	<p>393</p>	<p>394</p>
<p>395</p>	<p>396</p>	<p>397</p>	<p>398</p>
<p>399</p>	<p>400</p>	<p>401</p>	<p>402</p>
<p>403</p>	<p>404</p>	<p>405</p>	<p>406</p>
<p>407</p>	<p>408</p>	<p>409</p>	<p>410</p>
<p>411</p>	<p>412</p>	<p>413</p>	<p>414</p>
<p>415</p>	<p>416</p>	<p>417</p>	<p>418</p>
<p>419</p>	<p>420</p>	<p>421</p>	<p>422</p>
<p>423</p>	<p>424</p>	<p>425</p>	<p>426</p>
<p>427</p>	<p>428</p>	<p>429</p>	<p>430</p>
<p>431</p>	<p>432</p>	<p>433</p>	<p>434</p>
<p>435</p>	<p>436</p>	<p>437</p>	<p>438</p>
<p>439</p>	<p>440</p>	<p>441</p>	<p>442</p>
<p>443</p>	<p>444</p>	<p>445</p>	<p>446</p>
<p>447</p>	<p>448</p>	<p>449</p>	<p>450</p>
<p>451</p>	<p>452</p>	<p>453</p>	<p>454</p>
<p>455</p>	<p>456</p>	<p>457</p>	<p>458</p>
<p>459</p>	<p>460</p>	<p>461</p>	<p>462</p>
<p>463</p>	<p>464</p>	<p>465</p>	<p>466</p>
<p>467</p>	<p>468</p>	<p>469</p>	<p>470</p>
<p>471</p>	<p>472</p>	<p>473</p>	<p>474</p>
<p>475</p>	<p>476</p>	<p>477</p>	<p>478</p>
<p>479</p>	<p>480</p>	<p>481</p>	<p>482</p>
<p>483</p>	<p>484</p>	<p>485</p>	<p>486</p>
<p>487</p>	<p>488</p>	<p>489</p>	<p>490</p>
<p>491</p>	<p>492</p>	<p>493</p>	<p>494</p>
<p>495</p>	<p>496</p>	<p>497</p>	<p>498</p>
<p>499</p>	<p>500</p>	<p>501</p>	<p>502</p>
<p>503</p>	<p>504</p>	<p>505</p>	<p>506</p>
<p>507</p>	<p>508</p>	<p>509</p>	<p>510</p>
<p>511</p>	<p>512</p>	<p>513</p>	<p>514</p>
<p>515</p>	<p>516</p>	<p>517</p>	<p>518</p>
<p>519</p>	<p>520</p>	<p>521</p>	<p>522</p>
<p>523</p>	<p>524</p>	<p>525</p>	<p>526</p>
<p>527</p>	<p>528</p>	<p>529</p>	<p>530</p>
<p>531</p>	<p>532</p>	<p>533</p>	<p>534</p>
<p>535</p>	<p>536</p>	<p>537</p>	<p>538</p>
<p>539</p>	<p>540</p>	<p>541</p>	<p>542</p>
<p>543</p>	<p>544</p>	<p>545</p>	<p>546</p>
<p>547</p>	<p>548</p>	<p>549</p>	<p>550</p>
<p>551</p>	<p>552</p>	<p>553</p>	<p>554</p>
<p>555</p>	<p>556</p>	<p>557</p>	<p>558</p>
<p>559</p>	<p>560</p>	<p>561</p>	<p>562</p>
<p>563</p>	<p>564</p>	<p>565</p>	<p>566</p>
<p>567</p>	<p>568</p>	<p>569</p>	<p>570</p>
<p>571</p>	<p>572</p>	<p>573</p>	<p>574</p>
<p>575</p>	<p>576</p>	<p>577</p>	<p>578</p>
<p>579</p>	<p>580</p>	<p>581</p>	<p>582</p>
<p>583</p>	<p>584</p>	<p>585</p>	<p>586</p>
<p>587</p>	<p>588</p>	<p>589</p>	<p>590</p>
<p>591</p>	<p>592</p>	<p>593</p>	<p>594</p>
<p>595</p>	<p>596</p>	<p>597</p>	<p>598</p>
<p>599</p>	<p>600</p>	<p>601</p>	<p>602</p>
<p>603</p>	<p>604</p>	<p>605</p>	<p>606</p>
<p>607</p>	<p>608</p>	<p>609</p>	<p>610</p>
<p>611</p>	<p>612</p>	<p>613</p>	<p>614</p>
<p>615</p>	<p>616</p>	<p>617</p>	<p>618</p>
<p>619</p>	<p>620</p>	<p>621</p>	<p>622</p>
<p>623</p>	<p>624</p>	<p>625</p>	<p>626</p>
<p>627</p>	<p>628</p>	<p>629</p>	<p>630</p>
<p>631</p>	<p>632</p>	<p>633</p>	<p>634</p>
<p>635</p>	<p>636</p>	<p>637</p>	<p>638</p>
<p>639</p>	<p>640</p>	<p>641</p>	<p>642</p>
<p>643</p>	<p>644</p>	<p>645</p>	<p>646</p>
<p>647</p>	<p>648</p>	<p>649</p>	<p>650</p>
<p>651</p>	<p>652</p>	<p>653</p>	<p>654</p>
<p>655</p>	<p>656</p>	<p>657</p>	<p>658</p>
<p>659</p>	<p>660</p>	<p>661</p>	<p>662</p>
<p>663</p>	<p>664</p>	<p>665</p>	<p>666</p>
<p>667</p>	<p>668</p>	<p>669</p>	<p>670</p>
<p>671</p>	<p>672</p>	<p>673</p>	<p>674</p>
<p>675</p>	<p>676</p>	<p>677</p>	<p>678</p>
<p>679</p>	<p>680</p>	<p>681</p>	<p>682</p>



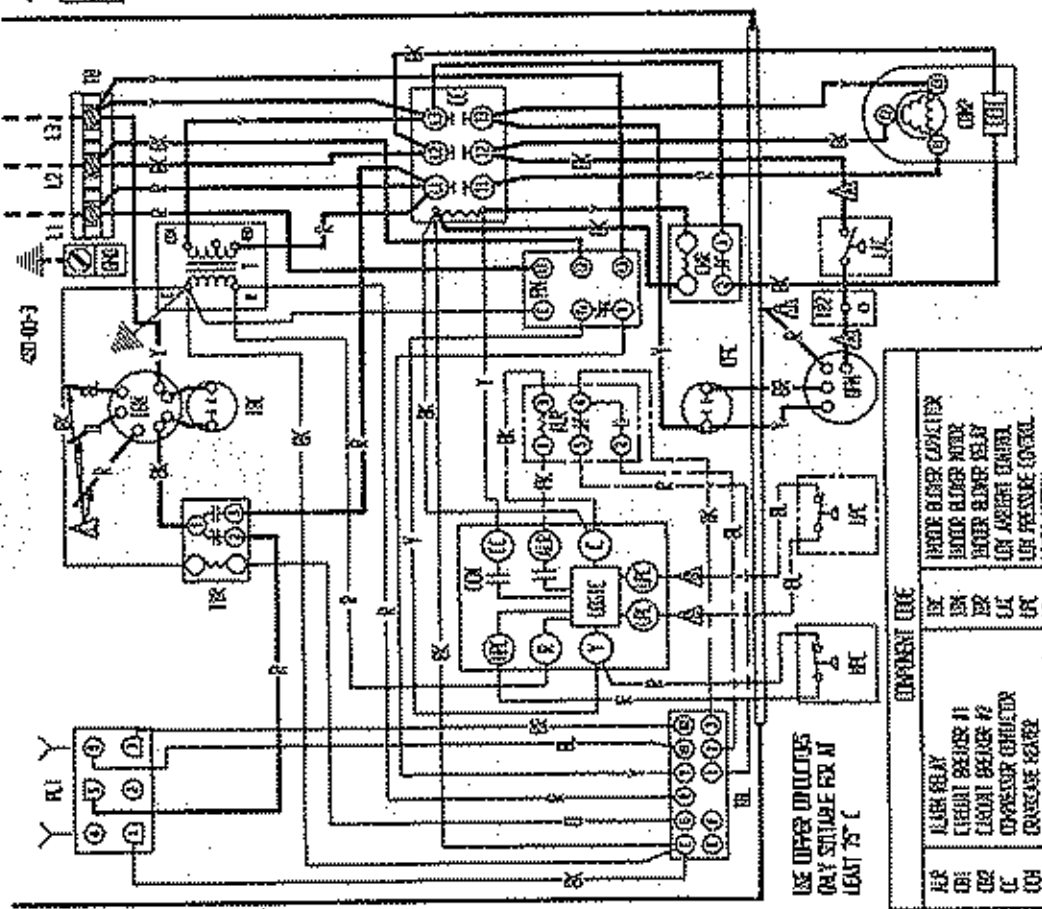
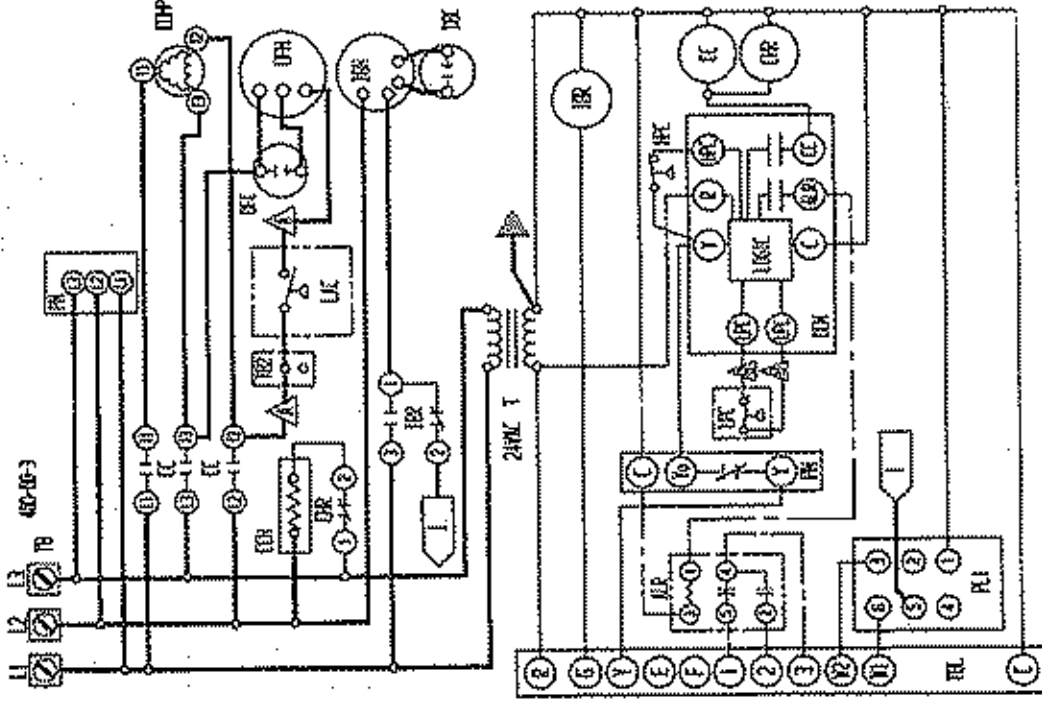

PER LINE & MOTOR SPEEDS INDICATED CHANGE TO BLACK. SEE (LWB) OR BLUE (RWH) TO 11 OF BFC.  $\Delta$  SEE (LWB) BLACK (RWH)  $\Delta$  SEE (LWB) BLUE (RWH)

$\Delta$  LINE PRESSURE CONTROL IF NO DIFFERENTIAL USED.  $\Delta$  PER HIGH SPEED MOTOR CHANGE. RED, BLUE LEADS SEPARATELY. INDICATE BLACK TO 11 OF BFC.

4095-320 C

HEAD WPC. 03.

WIRE COLOR		WIRE COLOR	
1	2	Y	Y
BLACK	BLK	YELLOW	Y
GRAY	GRY	GREEN	G
RED	RD	BLUE	B
ORANGE	ORG	WHITE	W

FACTORY NO.	FIND	OFFNO.

WIND VALUE	UN VALUE	MOVING

COMPONENT CODE	
UR	URSOLE
OR	ORSOLE
UR	URSOLE
OR	ORSOLE
UR	URSOLE
OR	ORSOLE
UR	URSOLE
OR	ORSOLE
UR	URSOLE
OR	ORSOLE
UR	URSOLE
OR	ORSOLE
UR	URSOLE
OR	ORSOLE
UR	URSOLE
OR	ORSOLE
UR	URSOLE
OR	ORSOLE

USE DIFFERENTIALS  
ONLY STRIPE PER N



