

**Installation
Instructions**

**Wall Mounted
Packaged Air Conditioner**

Models: WA301, WA361

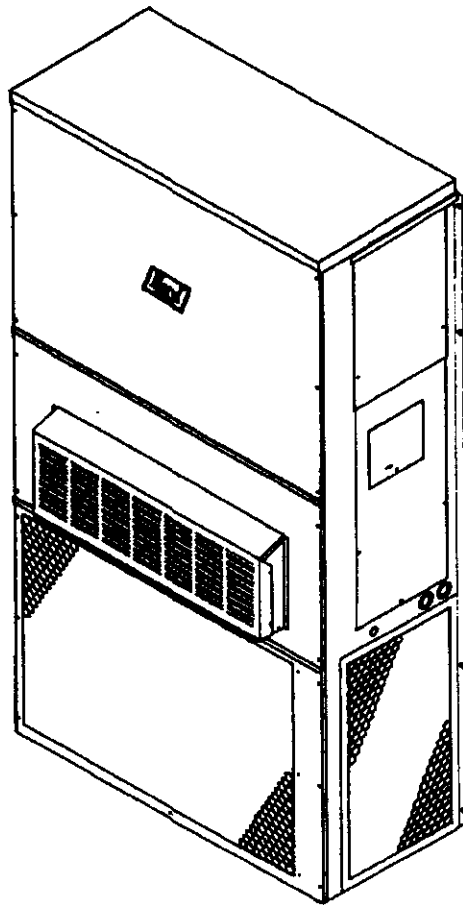

**Bard Manufacturing Company
Bryan, Ohio 43506**

*Since 1914...Moving ahead, just as
planned.*

**Manual No.: 2100-192 Rev.H
File: Volume III, Tab 16
/Date: 01/17/96**

© Copyright 1996

Contents

Getting Other Information and Publications	1
For more information, contact these publishers	1
Wall Mount General Information	2
Air Conditioner Wall Mount Model Nomenclature	2
Shipping Damage	4
General	4
Duct Work	4
Filters	4
Fresh Air Intake	4
Condensate Drain	4
Installation Instructions	5
Wall Mounting Information	5
Mounting the Unit	5
Wiring — Main Power	5
Wiring — Low Voltage Wiring	6

Figures

Figure 1	Unit Dimensions	3
Figure 2	Mounting Instructions	6
Figure 3	Electric Heat Clearances	7
Figure 4	Airframe Angles	7
Figure 5	Soffit Installation	7
Figure 6	Wall-Mounting Instructions	8
Figure 7	Wall-mounting Instructions	8
Figure 8	Wiring	9
Figure 9	Start-Up Label	10
Figure 10	Fan Blade Setting	11

Start Up	10
Important Installer Note	10
Crankcase Heaters	10
Service Hints	10
Sequence of Operation	10
Pressure Service Ports	10
Troubleshooting	11
Fan Blade Setting Dimensions	11
Removal of Fan Shroud	11
Refrigerant Charge	11
Optional Accessories	12

Tables

Table 1	Electrical Specifications	2
Table 2	Dimensions of Basic Unit	3
Table 3	Electric Heat Table	3
Table 4	Operating Voltage Range	6
Table 5	Thermostat Wire Size	6
Table 6	Wall Thermostat and Subbase Combinations	6
Table 7	Fan Blade Dimensions	11
Table 8	Suction Line Temperatures	11
Table 9	Indoor Blower Performance	11
Table 10	CFM and ESP	11
Table 11	Maximum ESP of Operation Electric Heat Only	11
Table 13	Cooling Application Data	12
Table 14	Optional Accessories	12

Getting Other Information and Publications

These publications can help you install the air conditioner or heat pump. You can usually find these at your local library or purchase them directly from the publisher. Be sure to consult current edition of each standard.

- National Electrical Code ANSI/NFPA 70
- Standard for the Installation ANSI/NFPA 90A
of Air Conditioning and
Ventilating Systems
- Standard for Warm Air ANSI/NFPA 90B
Heating and Air
Conditioning Systems
- Load Calculation for ACCA Manual J
Residential Winter and
Summer Air Conditioning
- Duct Design for Residential ACCA Manual D
Winter and Summer Air
Conditioning and Equipment
Selection

For more information, contact these publishers:

ACCA — Air Conditioning Contractors of America
1513 16th Street N.W.
Washington, DC 20036
Telephone: (202) 483-9370
Fax: (202) 234-4721

ANSI — American National Standards Institute
11 West Street, 13th Floor
New York, NY 10036
Telephone: (212) 642-4900
Fax: (212) 302-1286

**ASHRAE — American Society of Heating Refrigerating, and
Air Conditioning Engineers, Incorporated**
1791 Tullie Circle, N.E.
Atlanta, GA 30329-2305
Telephone: (404) 636-8400
Fax: (404) 321-5478

NFPA — National Fire Protection Association
Batterymarch Park
P.O. Box 9101
Quincy, MA 02269-9901
Telephone: (800) 344-3555
Fax: (617) 984-7057

Manufactured under the following U.S. patent numbers:
5,301,744; 5,002,116; 4,924,934; 4,875,520; 4,825,936; 4,432,409
Other patents pending.

Wall Mount General Information

Air Conditioner Wall Mount Model Nomenclature

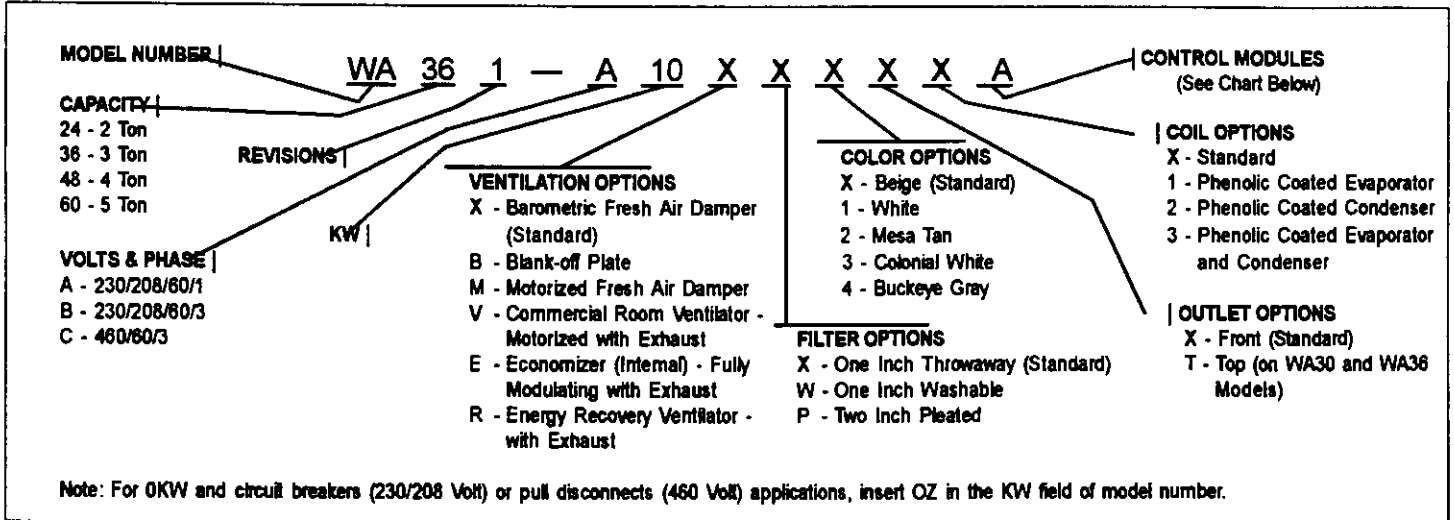

Table 1 — Electrical Specifications

MODELS	RATED VOLTS & PHASE	NO. FIELD POWER CIRCUITS	③ MINIMUM CIRCUIT AMPACITY	① MAXIMUM EXTERNAL FUSE OR CKT. BREAKER	② FIELD POWER WIRE SIZE	② GROUND WIRE SIZE	③ MINIMUM CIRCUIT AMPACITY		① MAXIMUM EXTERNAL FUSE OR CKT. BREAKER		② FIELD POWER WIRE SIZE		② GROUND WIRE SIZE	
							CKTA	CKT.B	CKTA	CKT.B	CKTA	CKT.B	CKTA	CKT.B
WA301-A00, A0Z	230/208-1	1	24	35	8	10	—	—	—	—	—	—	—	—
A05		1	31	35	8	10	—	—	—	—	—	—	—	
A10		1	57	60	6	10	—	—	—	—	—	—	—	
A15		1 or 2	83	90	4	8	55	26	60	30	4	10	8	10
WA301-B00, B0Z	230/208-3	1	17	20	12	12	—	—	—	—	—	—	—	—
B09		1	32	35	8	10	—	—	—	—	—	—	—	
B15		1	50	50	8	10	—	—	—	—	—	—	—	
WA301-C00, C0Z	460-3	1	10	15	14	14	—	—	—	—	—	—	—	—
C09		1	17	20	12	12	—	—	—	—	—	—	—	
C15		1	26	30	10	10	—	—	—	—	—	—	—	
WA361-A00, A0Z	230/208-1	1	27	35	8	10	—	—	—	—	—	—	—	—
A05		1	31	35	8	10	—	—	—	—	—	—	—	
A10		1	57	60	6	10	—	—	—	—	—	—	—	
A15		1 or 2	83	90	4	8	55	26	60	30	4	10	8	10
WA361-B00, B0Z	230/208-3	1	20	25	10	10	—	—	—	—	—	—	—	—
B09		1	32	35	8	10	—	—	—	—	—	—	—	
B15		1	50	50	8	10	—	—	—	—	—	—	—	
WA361-C00, C0Z	460-3	1	10	15	14	14	—	—	—	—	—	—	—	—
C09		1	17	20	12	12	—	—	—	—	—	—	—	
C15		1	26	30	10	10	—	—	—	—	—	—	—	

① Maximum size of the time delay fuse or HACR type circuit breaker for protection of field wiring conductors.

② Based on 75°C copper wire. All wiring must conform to the National Electrical Code and all local codes.

③ These "Minimum Circuit Ampacity" values are to be used for sizing the field power conductors. Refer to the National Electric Code (latest revision), article 310 for power conductor sizing. Caution: When more than one field power conductor circuit is run through one conduit, the conductors must be derated. Pay special attention to note 8 of table 310 regarding Ampacity Adjustment Factors when more than three conductors are in a raceway.

Table 2 — Dimensions of Basic Unit for Architectural and Installation Requirements (Nominal)

UNIT	WIDTH (W)	DEPTH (D)	HEIGHT (H)	SUPPLY		RETURN		E	F	G	I	J	K	L	M	N	O	P	Q	U*	V*	W*
				A	B	C	B															
WA301	37-7/8	16-7/8	70-1/2	7-7/8	27-7/8	13-7/8	27-7/8	39-7/8	18-1/4	25-3/4	18	26-3/4	28-3/4	29-1/4	27	2-9/16	39	22-3/4	9	7-7/8	1	31-7/8
WA361																						

All dimensions are in inches

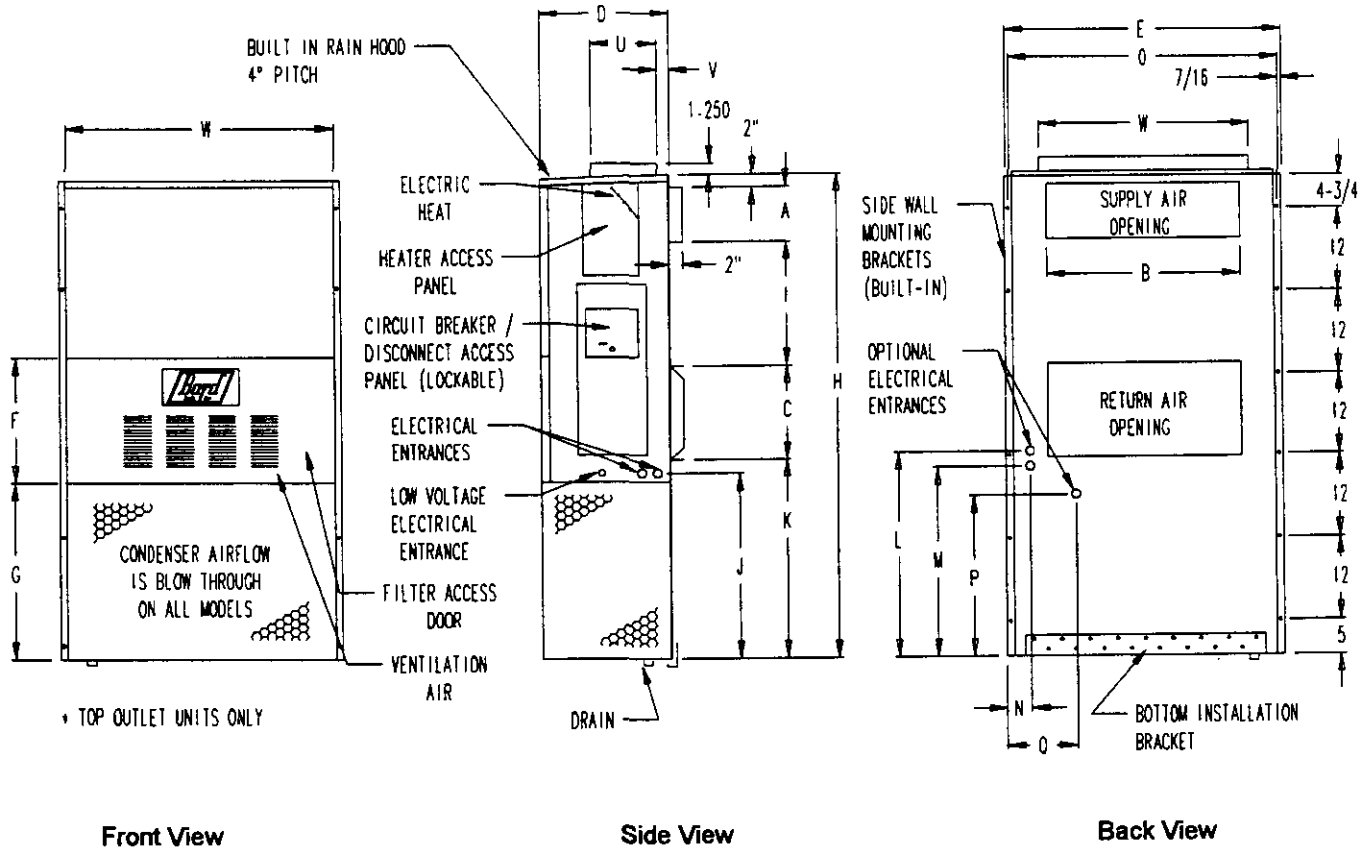

Figure 1 — Unit Dimensions

Table 3 — Electric Heat Table

MODELS	WA301-A		WA301-B		WA301-C		WA361-A		WA361-B		WA361-C				
	240V-1	208V-1	240V-3	208V-3	460V-3	240V-1	208V-1	240V-3	208V-3	460V-3	AMPS	BTUH			
5.0	20.8	17,065	18.1	12,800		20.8	17,065	18.1	12,800						
8.0	33.3	27,300	28.8	20,475		33.3	27,300	28.8	20,475						
10.0	41.6	34,130	36.2	25,600		41.6	34,130	36.2	25,600						
15.0						62.5	51,200	54.1	38,400						
6.0			14.4	20,500	12.5	15,360	7.2	20,475		14.4	20,500	12.5	15,360	7.2	20,475
9.0			21.7	30,600	18.7	23,030	10.8	30,700		21.7	30,600	18.7	23,030	10.8	30,700
15.0						18.0	51,200			36.2	51,200	31.2	38,400	18.0	51,200

Shipping Damage

Upon receipt of equipment, the carton should be checked for external signs of shipping damage. If damage is found, the receiving party must contact the last carrier immediately, preferably in writing, requesting inspection by the carrier's agent.

General

The equipment covered in this manual is to be installed by trained, experienced service and installation technicians.

The refrigerant system is completely assembled and charged. All internal wiring is complete.

The unit is designed for use with or without duct work. Flanges are provided for attaching the supply and return ducts.

These instructions explain the recommended method to install the air cooled self-contained unit and the electrical wiring connections to the unit.

These instructions and any instructions packaged with any separate equipment required to make up the entire air conditioning system should be carefully read before beginning the installation. Note particularly "Starting Procedure" and any tags and/or labels attached to the equipment.

While these instructions are intended as a general recommended guide, they do not supersede any national and/or local codes in any way. Authorities having jurisdiction should be consulted before the installation is made. See Page 1 for information on codes and standards.

Size of unit for a proposed installation should be based on heat loss calculation made according to methods of Air Conditioning Contractors of America (ACCA). The air duct should be installed in accordance with the Standards of the National Fire Protection Association for the Installation of Air Conditioning and Ventilating Systems of Other Than Residence Type, NFPA No. 90A, and Residence Type Warm Air Heating and Air Conditioning Systems, NFPA No. 90B. Where local regulations are at a variance with instructions, installer should adhere to local codes.

Duct Work

Any heat pump is more critical of proper operating charge and an adequate duct system than a straight air conditioning unit. All duct work, supply and return, must be properly sized for the design air flow requirement of the equipment. Air Conditioning Contractors of America (ACCA) is an excellent guide to proper sizing. All duct work or portions thereof not in the conditioned space should be properly insulated in order to both conserve energy and prevent condensation or moisture damage.

Refer to Table 10 for maximum static pressure available for duct design.

Design the duct work according to methods given by the Air Conditioning Contractors of America (ACCA). When duct runs through unheated spaces, it should be insulated with a minimum of 1-inch of insulation. Use insulation with a vapor barrier on the outside of the insulation. Flexible joints should be used to connect

the duct work to the equipment in order to keep the noise transmission to a minimum.

A 1/4-inch clearance to combustable material for the first 3 feet of duct attached to the outlet air frame is required. See Wall Mounting Instructions and Figures 2 and 3 for further details.

Ducts through the walls must be insulated and all joints taped or sealed to prevent air or moisture entering the wall cavity.



CAUTION

Some installations may not require any return air duct. A metallic return air grille is required with installations not requiring a return air duct. The spacing between louvers on the grille shall not be larger than 5/8 inches.

Any grille that meets the 5/8 inch louver criteria, may be used. It is recommended that Bard Return Air Grille Kit RG2 thru RG5 or RFG2 thru RFG5 be installed when no return duct is used. Contact distributor or factory for ordering information. If using a return air filter grille, filters must be of sufficient size to allow a maximum velocity of 400 fpm.

NOTE: If no return air duct is used, applicable installation codes may limit this cabinet to installation only in a single story structure.

Filters

A 1-inch throwaway filter is supplied with each unit. The filter slides into position making it easy to service. This filter can be serviced from the outside by removing the service door. A 1-inch washable filter and 2-inch pleated filter are also available as optional accessories. The internal filter brackets are adjustable to accommodate the 2-inch filter by loosening 2 screws in each bracket assembly and sliding the brackets apart to the required width and retightening the 4 screws.

Fresh Air Intake

All units are built with fresh air inlet slots punched in the service panel.

The fresh air damper assembly is standard equipment with the unit because of the variety of state or local codes requiring fresh air capability. It is shipped already attached to each unit.

All capacity, efficiency and cost of operation information as required for Department of Energy "Energyguide" Fact Sheets is based upon the fresh air blank-off plate in place and is recommended for maximum energy efficiency.

The blank-off plate is available upon request from the factory and is installed in place of the fresh air damper shipped with each unit.

Condensate Drain

A plastic drain hose extends from the drain pan at the top of the unit down to the unit base. There are openings in the unit base for the drain hose to pass through. In the event the drain hose is connected to a drain system of some type, it must be an open or vented type system to assure proper drainage.

Installation Instructions

Wall Mounting Information

1. Two holes, for the supply and return air openings, must be cut through the wall as shown in Figure 2.
2. On wood-frame walls, the wall construction must be strong and rigid enough to carry the weight of the unit without transmitting any unit vibration.



WARNING

Fire hazard can result if 1/4-inch clearance to combustible materials for supply air duct is not maintained. See Figure 2.

3. Concrete block walls must be thoroughly inspected to insure that they are capable of carrying the weight of the installing unit.

Mounting the Unit

1. These units are secured by wall mounting brackets which secure the unit to the outside wall surface at both sides. A bottom mounting bracket is provided for ease of installation, but is not required.
2. The unit itself is suitable for "0" inch clearance, but the supply air duct flange and the first 3 feet of supply air duct require a minimum of 1/4-inch clearance to combustible material. If a combustible wall, use a minimum of 28-1/2" x 8-1/2" dimensions for sizing. However, it is generally recommended that a 1-inch clearance is used for ease of installation and maintaining the required clearance to combustible material. The supply air opening would then be 30" x 10". See Figures 2 and 3 for details.



WARNING

Failure to provide the 1/4-inch clearance between the supply duct and a combustible surface for the first 3 feet of duct can result in fire.

3. Locate and mark lag bolt locations and bottom mounting bracket location. See Figure 2.
4. Mount bottom mounting bracket.
5. Hook top rain flashing under back bend of top. Top rain flashing is shipped secured to the right side of the back.
6. Position unit in opening and secure with 5/16 lag bolts; use 7/8-inch diameter flat washers on the lag bolts.
7. Secure rain flashing to wall and caulk across entire length of top. See Figure 2.
8. For additional mounting rigidity, the return air and supply air frames or collars can be drilled and screwed or welded to the

structural wall itself (depending upon wall construction). Be sure to observe required clearance if combustible wall.

9. On side by side installations, maintain a minimum of 20-inches clearance on right side to allow access to heat strips and control panel and to allow proper airflow to the outdoor coil. Additional clearance may be required to meet local or national codes.

Top Outlet Only

1. Remove airframe angles from the back of the unit.
2. Coat angles with two 1/8" beads of silicone as shown. Silicone is shipped in the control panel. See Figure 3.
3. Secure angles to the top of the unit with 14 screws provided. Use of prepunched holes provided. Do not relocate. See Figure 3.
4. After installation ductwork, seal around airframe and ductwork to provide a rain tight seal.
5. It is strongly recommended, but not required, that this unit be installed under a soffit area large enough to shield the top of the unit. See Figure 5.

Wiring — Main Power

Refer to the unit rating plate for wire sizing information and maximum fuse or "HACR Type" circuit breaker size. Each outdoor unit is marked with a "Minimum Circuit Ampacity". This means that the field wiring used must be sized to carry that amount of current. Depending on the installed KW of electric heat, there may be two field power circuits required. If this is the case, the unit serial plate will so indicate. All models are suitable only for connection with copper wire. Each unit and/or wiring diagram will be marked "Use Copper Conductors Only". These instructions **must** be adhered to. Refer to the National Electrical Code (NEC) for complete current carrying capacity data on the various insulation grades of wiring material. All wiring must conform to NEC and all local codes.

The electrical data lists fuse and wire sizes (75°C copper) for all models, including the most commonly used heater sizes. Also shown are the number of field power circuits required for the various models with heaters.

The unit rating plate lists a "Maximum Time Delay Relay Fuse" or "HACR Type" circuit breaker that is to be used with the equipment. The correct size must be used for proper circuit protection and also to assure that there will be no nuisance tripping due to the momentary high starting current of the compressor motor.

The disconnect access door on this unit may be locked to prevent unauthorized access to the disconnect. To convert for the locking capability, bend the tab located in the bottom left hand corner of the disconnect opening under the disconnect access panel straight out. This tab will now line up with the slot in the door. When shut, a padlock may be placed through the hole in the tab preventing entry.

Wiring — Low Voltage Wiring

230/208V, 1 phase and 3 phase equipment dual primary voltage transformers. All equipment leaves the factory wired on 240V tap. For 208V operation, reconnect from 240V to 208V tap. The acceptable operating voltage range for the 240 and 208V taps are:

Table 4 — Operating Voltage Range

TAP	RANGE
240V	253 - 216
208V	220 - 187

NOTE: The voltage should be measured at the field power connection point in the unit and while the unit is operating at full load (maximum amperage operating condition).

Five (5) wires should be run from thermostat subbase to the 24V terminal board in the unit. A five conductor, 18 gauge copper, color-coded thermostat cable is recommended. The connection points are shown in Figure 6.

Table 5 — Thermostat Wire Size

TRANSFORMER VA	FLA	WIRE GAUGE	MAXIMUM DISTANCE IN FEET
55	2.3	20 gauge	45
		18 gauge	60
		16 gauge	100
		14 gauge	160
		12 gauge	250

Table 6 — Wall Thermostat and Subbase Combinations

THERMOSTAT	SUBBASE	PREDOMINATE FEATURES
8403-002	8404-003	1 stage heat, 1 stage cool
T87F#111	Q539A1220	System: heat-off-cool Fan: auto-on
8103-009	—	1 stage heat, 1 stage cool
1F56-318	—	—
8403-019	8404-012	1 stage cool, 2 stage heat
T874C1760	Q674A1001	System: heat-auto-cool Fan: auto-on
8403-035	—	Programmable
1F95-80	—	Electronic

NOTE: It is recommended that a bead of silicone caulking be placed behind the side mounting flanges and under the top flashing at the time of installation.

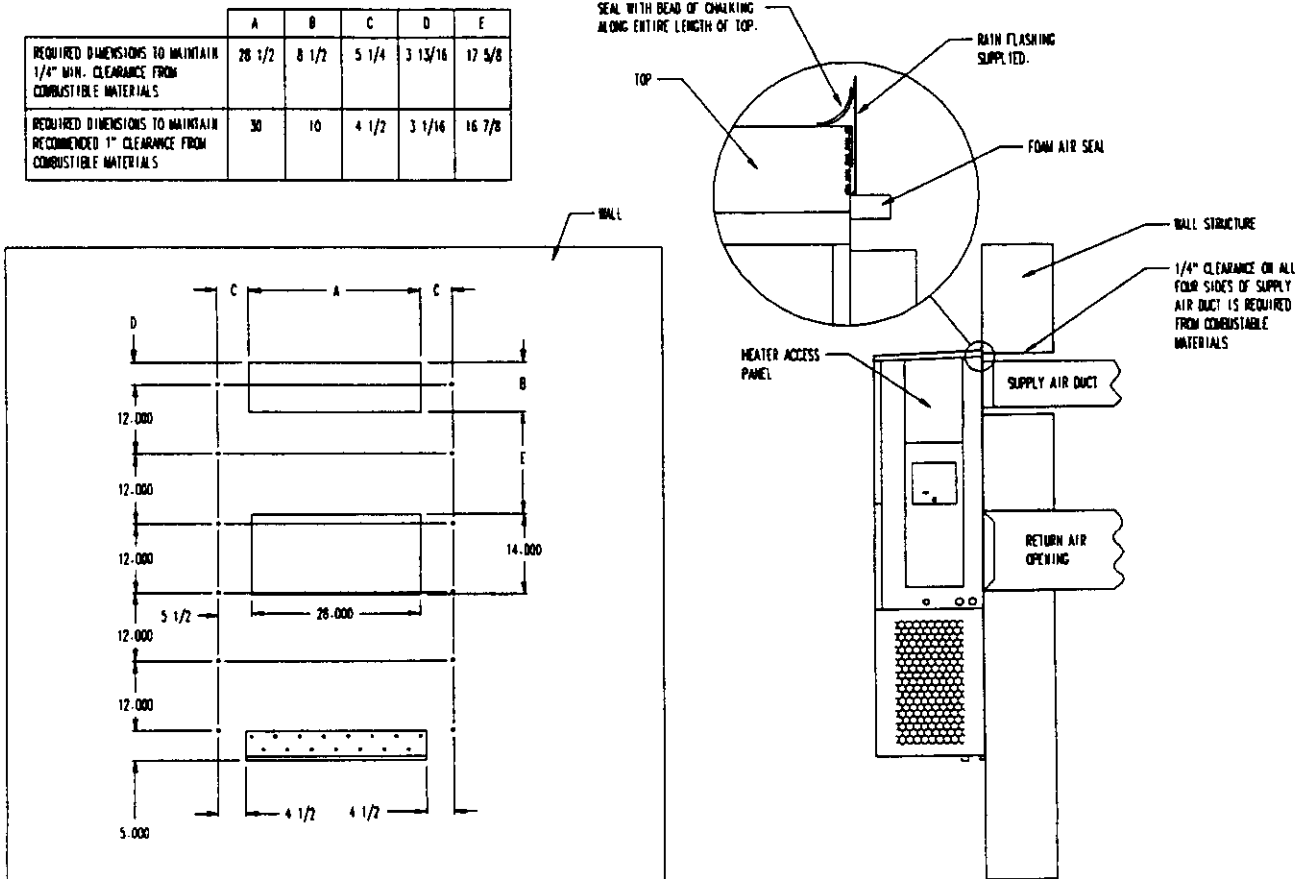
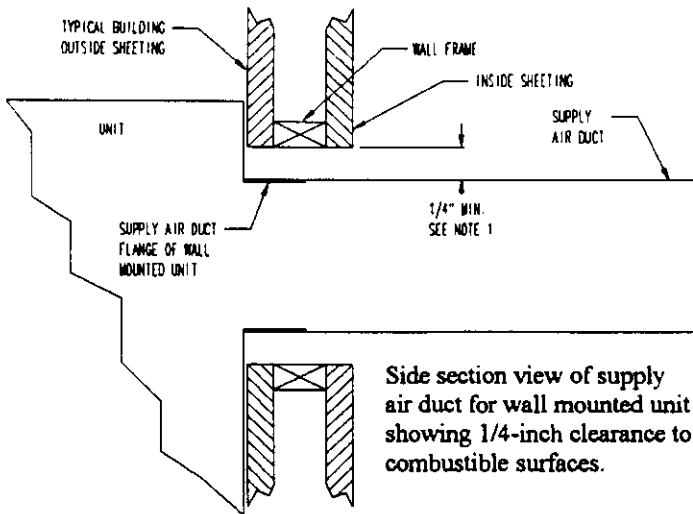

Figure 2 — Mounting Instructions



WARNING

- A minimum of 1/4-inch clearance must be maintained between the supply air duct and combustible materials. This is required for the first 3-feet of ducting.
- It is important to insure that the 1/4-inch minimum spacing is maintained at all points.
- Failure to do this could result in overheating the combustible material and may result in fire.

Figure 3 — Electric Heat Clearance

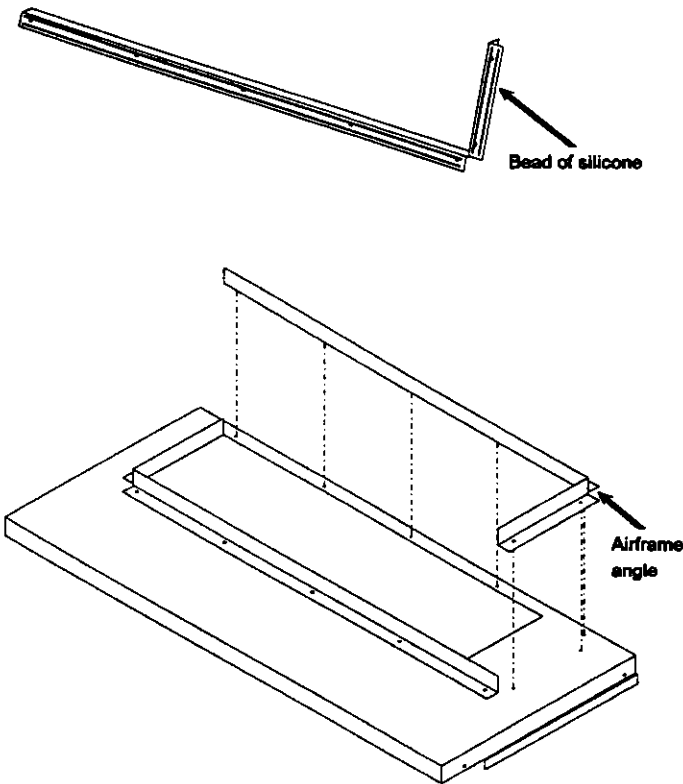

Figure 4 — Airframe Angles

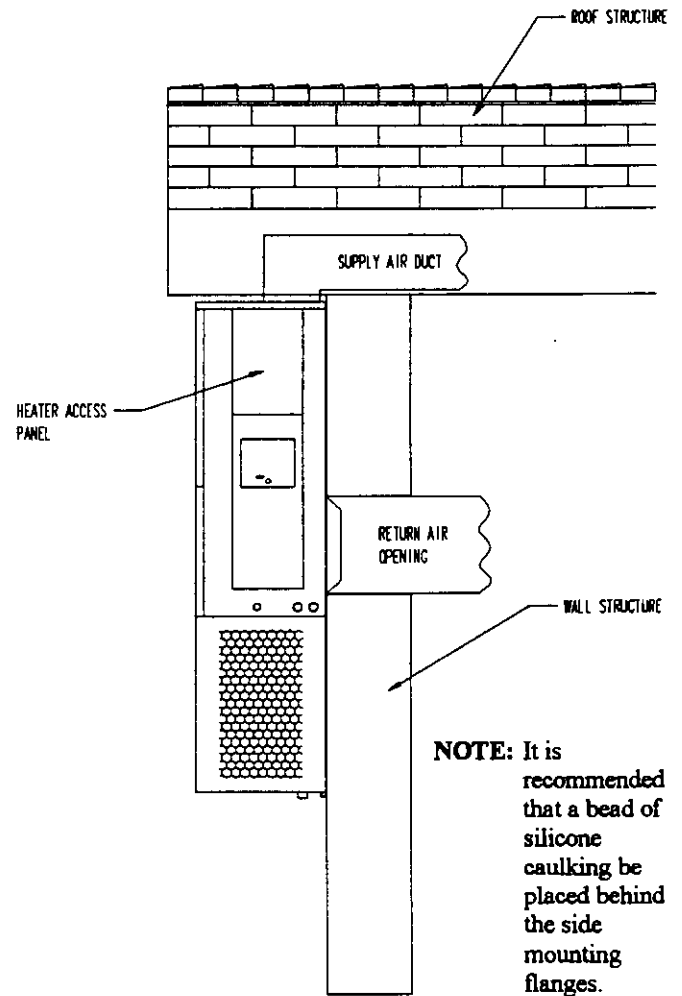
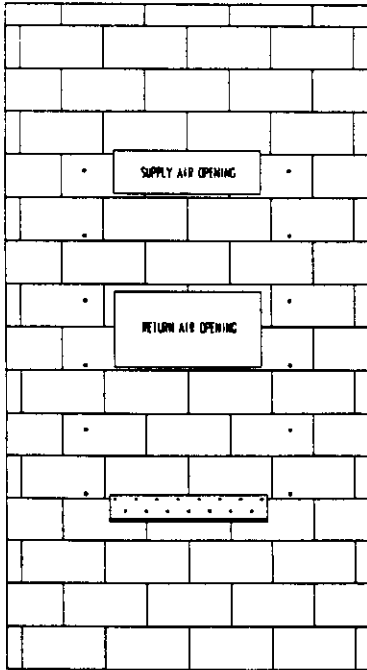
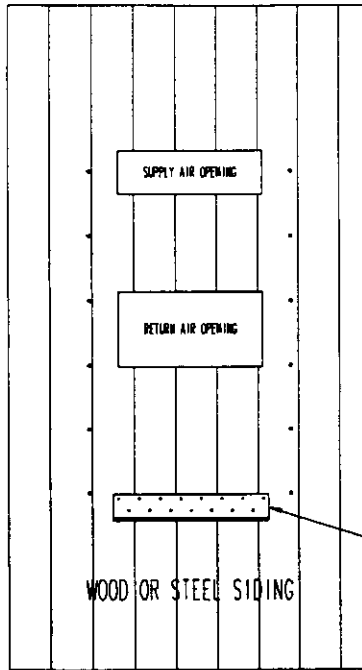

Figure 5 — Soffit Installation

SEE FIGURE 2 - MOUNTING INSTRUCTIONS



CONCRETE BLOCK WALL INSTALLATION



WOOD FRAME WALL INSTALLATION

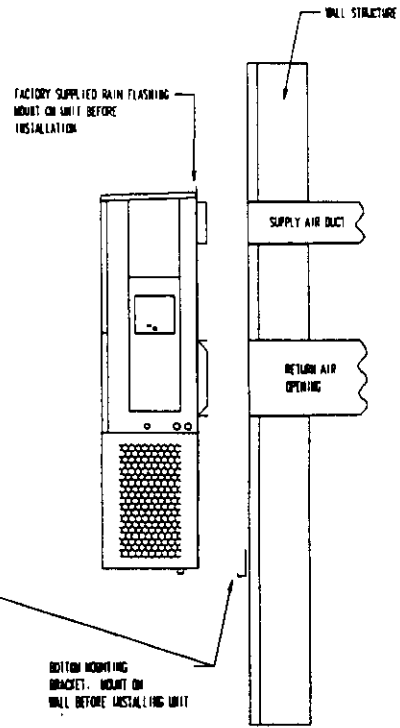

Figure 6 — Wall-Mounting Instructions

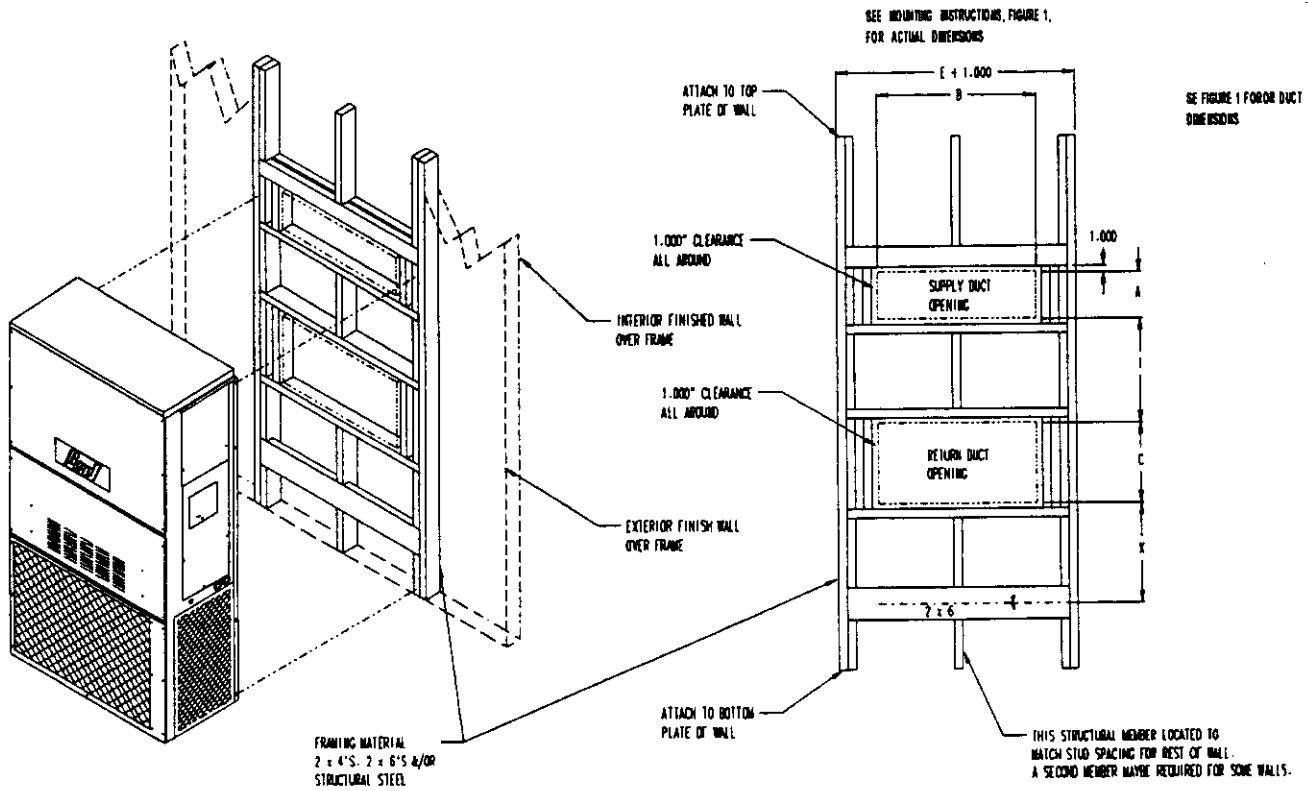
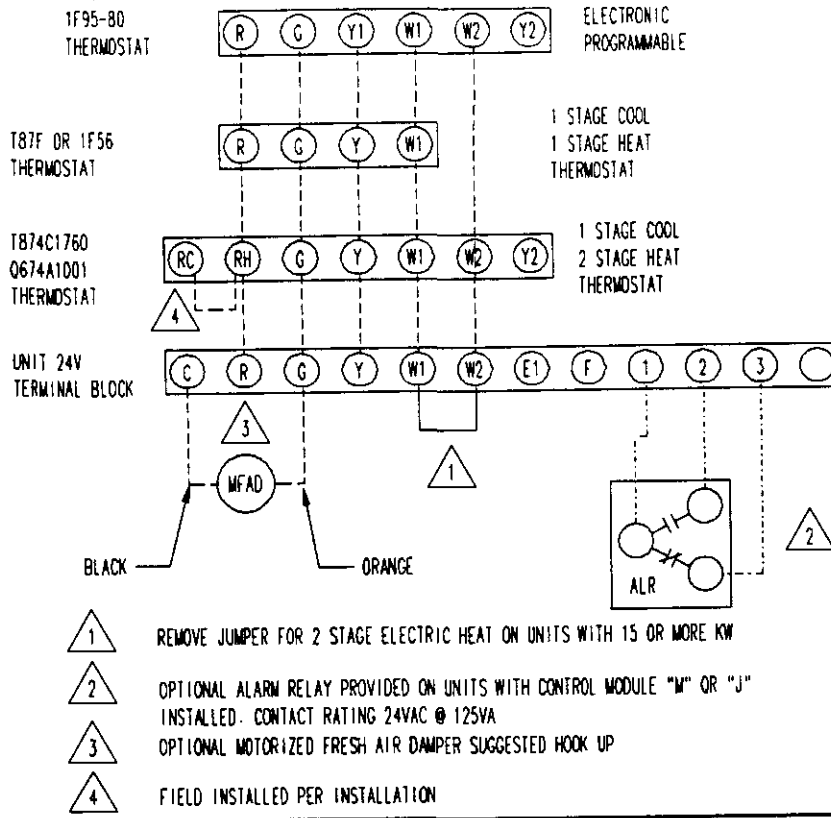

Figure 7 — Wall-Mounting Instructions

LOW VOLTAGE WIRING



OPTIONAL ECONOMIZER LOW VOLTAGE WIRING

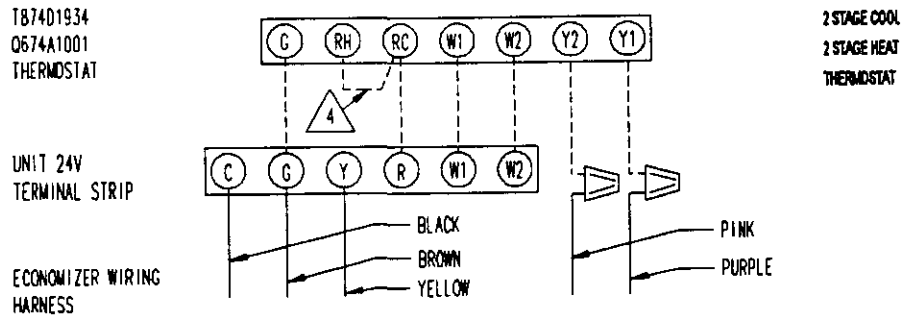

Figure 8 — Wiring

Start Up

Important Installer Note

For improved start-up performance, wash the indoor coil with a dishwasher detergent.

Crankcase Heaters

All units are provided with some form of compressor crankcase heat.

All single and three phase models have an insertion well-type heater located in the lower section of the compressor housing. This is a self-regulating type heater that draws only enough power to maintain the compressor at a safe temperature.

Some form of crankcase heat is essential to prevent liquid refrigerant from migrating to the compressor, causing oil pump out on compressor start-up and possible valve failure due to compressing a liquid.

The decal in Figure 9 is affixed to all outdoor units detailing start-up procedure. This is very important. Please read carefully.

Figure 9 — Start-Up Label

IMPORTANT

These procedures must be followed at initial start-up and at any time power has been removed for 12 hours or longer.

To prevent compressor damage which may result from the presence of liquid refrigerant in the compressor crankcase.

1. Make certain the room thermostat is in the "off" position (the compressor is not to operate).
2. Apply power by closing the system disconnect switch. This energizes the compressor heater which evaporates the liquid refrigerant in the crankcase.
3. Allow 4 hours or 60 minutes per pound of refrigerant in the system as noted on the unit rating plate, whichever is greater.
4. After properly elapsed time, the thermostat may be set to operate the compressor.
5. Except as required for safety while servicing—Do not open system disconnect switch.

7961-061

3. The heat pump wall thermostats perform multiple functions. Be sure that all function switches are correctly set for the desired operating mode before trying to diagnose any reported service problems.
4. Check all power fuses or circuit breakers to be sure they are the correct rating.
5. Periodic cleaning of the outdoor coil to permit full and unrestricted airflow circulation is essential.

Sequence of Operation

Cooling—Circuit R-Y makes at thermostat pulling in compressor contactor, starting the compressor and outdoor motor. The G (indoor motor) circuit is automatically completed on any call for cooling operation or can be energized by manual fan switch on subbase for constant air circulation. On a call for heating, circuit R-W1 make at the thermostat pulling in heat contact for the strip heat and blower operation. On a call for second stage heat, R-W2 makes bringing on second heat contactor, if so equipped.

Pressure Service Ports

High and low pressure service ports are installed on all units so that the system operating pressures can be observed. Pressure curves can be found later in the manual covering all models. It is imperative to match the correct pressure curve to the unit by model number.

Service Hints

1. Caution homeowner to maintain clean air filters at all times. Also, not to needlessly close off supply and return air registers. This reduces air flow through the system, which shortens equipment service life as well as increasing operating costs.
2. Switching to heating cycle at 75°F or higher outside temperature may cause a nuisance trip of the remote reset high pressure switch. Turn thermostat off, then on to reset the high pressure switch.

Troubleshooting

Fan Blade Setting Dimensions

Shown in the drawing below are the correct fan blade setting dimensions for proper air delivery across the outdoor coil.

Any service work requiring removal or adjustment in the fan and/or motor area will require that the dimensions below be checked and blade adjusted in or out on the motor shaft accordingly.

Figure 10 — Fan Blade Setting

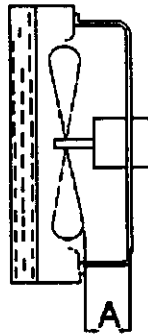

Table 7 — Fan Blade Dimensions

MODEL	DIMENSION A
WA301	1.25
WA361	1.25

Removal of Fan Shroud

1. Disconnect all power to unit.
2. Remove the screws holding both grills — one on each side of unit — and remove grills.
3. Remove screws holding fan shroud to condenser and bottom — 9 screws.
4. Unwire condenser fan motor.
5. Slide complete motor, fan blade, and shroud assembly out the left side of the unit.
6. Service motor/fan as needed.
7. Reverse steps to reinstall.

Refrigerant Charge

The correct system R-22 charge is shown on the unit rating plate. Optimum unit performance will occur with a refrigerant charge resulting in a suction line temperature (6-inches from compressor) as shown in the following table:

Table 8 — Suction Line Temperatures

MODEL	RATED AIRFLOW	95°F	82°F
		OD TEMPERATURE	OD TEMPERATURE
WA301	1,100	55 - 57	64 - 66
WA361	1,100	57 - 59	62 - 64

The above suction line temperatures are based upon 80°F dry bulb/ 67°F wet bulb (50 percent R.H.) temperature and rated airflow across the evaporator during cooling cycle.

Table 9 — Indoor Blower Performance — CFM at 230 Volts

E.S.P. In H ₂ O	WA301	
	HIGH SPEED DRY / WET COIL	LOW SPEED DRY / WET COIL
.0	1,395 / 1,315	950/935
.1	1,340 / 1,270	930/915
.2	1,285 / 1,180	910/885
.3	1,205 / 1,100	855/830
.4	1,110 / 1,000	800/755
.5	1,005 / 870	—

Table 10 — CFM and ESP

Model	Rated CFM [ⓐ]	Rated ESP [ⓐ]	Recommended Airflow Range
WA301	1,100	.30	930 - 1,300
WA361	1,100	.30	930 - 1,350

[ⓐ] Rated CFM and ESP on high speed tap.

Table 11 — Maximum ESP of Operation Electric Heat Only

Model	Front Outlet		Top Outlet	
	Low Speed	High Speed	Low Speed	High Speed
A00	.50	.50	.50	.50
A05	.50	.50	.45	.50
A08	.50	.50	—	—
A10	.45	.50	.35	.50
A15	.35	.40	—	—
B00	.50	.50	.50	.50
B06	.40	.50	—	—
B09	.50	.50	.40	.45
B15	.30	.45	—	—
C00	.50	.50	.50	.50
C06	.50	.50	—	—
C09	.40	.50	.40	.45
C15	.35	.45	—	—

Values shown are for units equipped with STD 1-inch throwaway filter or 1-inch washable filter. Derate ESP by .15 for 2-inch pleated filters.

Table 12 — Cooling Application Data — Outdoor Temperature °F ①

MODEL	② D.B./W.B.	COOLING CAPACITY	75°	80°	85°	90°	95°	100°	105°	110°	115°
WA301	75/	Total Cooling	74	77	79	81	82	84	85	85	86
	62	Sensible Cooling	218	232	247	262	277	292	308	325	341
	80/	Total Cooling	80	82	84	86	88	89	91	91	92
	67	Sensible Cooling	223	238	253	268	284	300	316	333	350
	85/	Total Cooling	85	88	91	93	95	96	97	98	99
	72	Sensible Cooling	231	246	262	278	294	310	327	345	362
WA361	75/	Total Cooling	70	72	74	76	78	79	80	81	82
	62	Sensible Cooling	224	242	259	275	290	304	316	328	339
	80/	Total Cooling	75	77	79	81	83	85	86	87	88
	67	Sensible Cooling	229	248	265	282	297	311	325	337	348
	85/	Total Cooling	80	83	85	87	89	91	92	94	95
	72	Sensible Cooling	238	257	275	292	307	322	336	349	360

Low side pressure ±2 psig

High side pressure ±5 psig

Tables are based upon rated CFM (airflow) across the evaporator coil and should be found under section titled "Refrigerant Charge" elsewhere in manual. If there is any doubt as to correct charge being in the system, the charge should be removed, system evacuated and recharged to serial plate instructions.

Table 13 — Optional Accessories

MODEL	DESCRIPTION	WA301-A	WA301-B	WA301-C	WA361-A	WA361-B	WA361-C
EHWA03-A05	Heater Packages ①	•			•		
EHWA03-A08	Heater Packages ①	•			•		
EHWA03-A10	Heater Packages ①	•			•		
EHWA03-A15	Heater Packages ①	•			•		
EHWA03-B06	Heater Packages ①		•			•	
EHWA03-B09	Heater Packages ①		•			•	
EHWA03-B15	Heater Packages ①		•			•	
EHWC03-C06	Heater Packages ①			•			•
EHWC03-C09	Heater Packages ①			•			•
EHWA03-C12	Heater Packages ①						•
EHWA03-C15	Heater Packages ①			•			•
BOP-3	Blank Off Plate	•	•	•	•	•	•
BFAD-3	Barometric Fresh Air Damper	•	•	•	•	•	•
MFAD-3	Motorized Fresh Air Damper	•	•	•	•	•	•
CRV-3	Commercial Ventilator with Exhaust	•	•	•	•	•	•
EIFM-3	Economizer with Exhaust	•	•	•	•	•	•
WERV-A3A	Energy Recovery Ventilator	•	•		•	•	
WERV-C3A	Energy Recovery Ventilator			•			•
CMA-1	High Pressure Control (HPC)	•	•	•	•	•	•
CMA-2	Low Pressure Control (LPC)	•	•	•	•	•	•
CMA-4	Low and High Pressure Control	•	•	•	•	•	•
CMA-5	Time Delay Relay (TDR)	•	•	•	•	•	•
CMA-6	Low Ambient Control (LAC)	•	•		•	•	
CMA-8	TDR + HPC	•	•	•	•	•	•
CMA-10	LPC + HPC + TDR	•	•	•	•	•	•
CMA-11	LPC + HPC + LAC	•	•		•	•	
CMA-12	LAC + TDR	•	•		•	•	
CMA-13	LPC + HPC + TDR + LAC	•	•		•	•	
CMC-15	Start Kit	•			•		
WMCB-05A	Circuit Breaker Kit	•			•		
WMCB-02B	Circuit Breaker Kit		•				
WMPD-01C	Pull Disconnect Kit			•			•
WMCB-03B	Circuit Breaker Kit					•	

① These heater packages not suitable for installation in top outlet units.

Note: Top outlet models are available only as factory built.

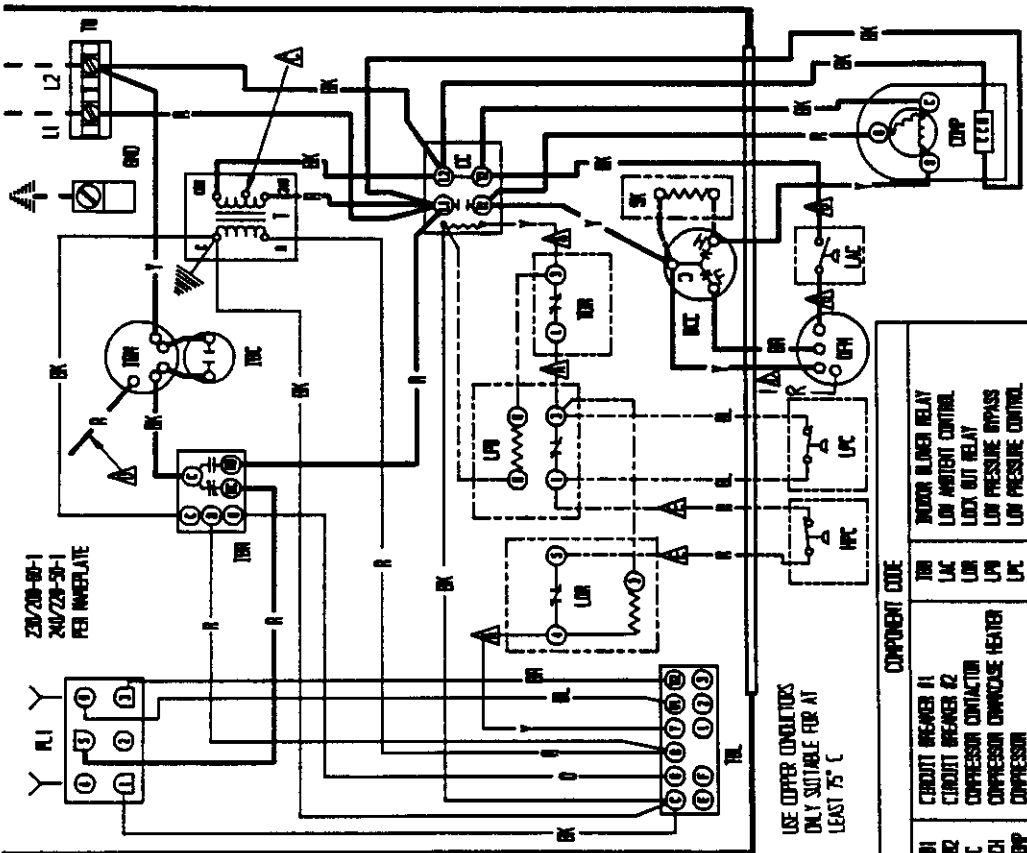
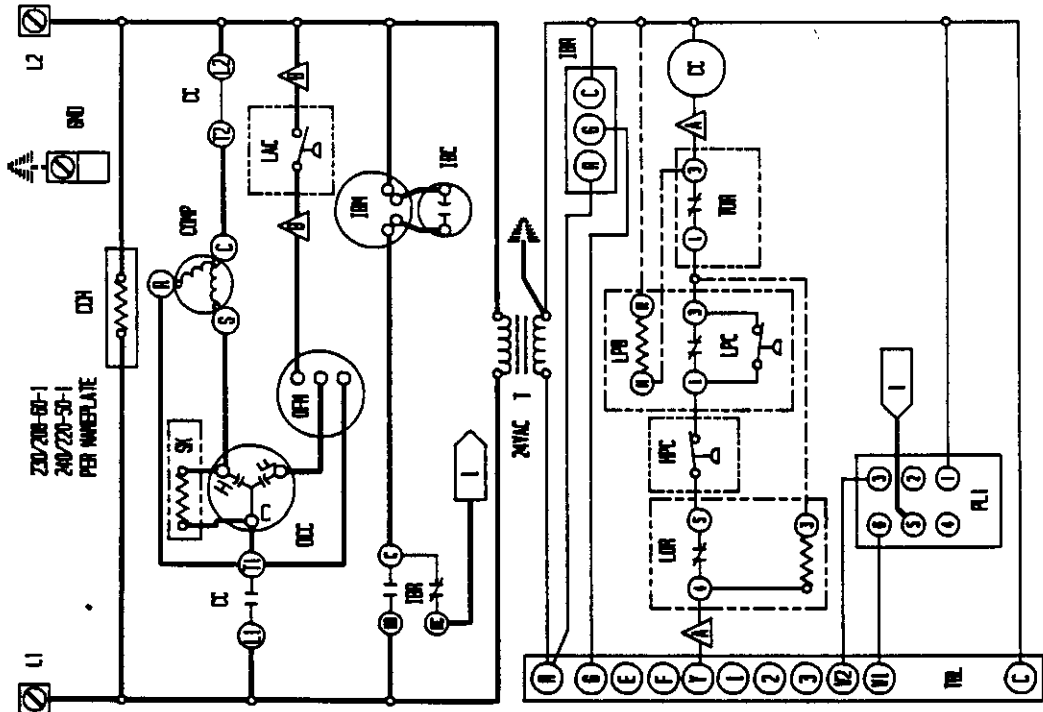

USE COPPER CONDUCTORS ONLY SUITABLE FOR AT LEAST 75° C

COMPONENT CODE	DESCRIPTION
CH1	CIRCUIT BREAKER #1
CH2	CIRCUIT BREAKER #2
CC1	COMPRESSOR CONTACTOR
CC2	COMPRESSOR CONTACTOR HEATER
CC3	COMPRESSOR
CC4	DUAL CAP CAPACITOR
CC5	EQUIPMENT GROUND
CC6	HEAT STRIP #1
CC7	HEAT STRIP #2
CC8	HEATER CONTACTOR #1
CC9	HEATER CONTACTOR #2
CC10	HIGH PRESSURE CONTROL
CC11	INDOOR BLOWER CAPACITOR
CC12	INDOOR BLOWER MOTOR
CH3	INDOOR BLOWER RELAY
CH4	LOW AMBIENT CONTROL
CH5	LOCK OUT RELAY
CH6	LOW PRESSURE BYPASS
CH7	LOW PRESSURE CONTROL
CH8	LOW PRESSURE CONTROL
CH9	LOW VOLTAGE CONTROL
CH10	LOW VOLTAGE CONTROL
CH11	LOW VOLTAGE CONTROL
CH12	LOW VOLTAGE CONTROL
CH13	LOW VOLTAGE CONTROL
CH14	LOW VOLTAGE CONTROL
CH15	LOW VOLTAGE CONTROL
CH16	LOW VOLTAGE CONTROL
CH17	LOW VOLTAGE CONTROL
CH18	LOW VOLTAGE CONTROL
CH19	LOW VOLTAGE CONTROL
CH20	LOW VOLTAGE CONTROL
CH21	LOW VOLTAGE CONTROL
CH22	LOW VOLTAGE CONTROL
CH23	LOW VOLTAGE CONTROL
CH24	LOW VOLTAGE CONTROL
CH25	LOW VOLTAGE CONTROL
CH26	LOW VOLTAGE CONTROL
CH27	LOW VOLTAGE CONTROL
CH28	LOW VOLTAGE CONTROL
CH29	LOW VOLTAGE CONTROL
CH30	LOW VOLTAGE CONTROL
CH31	LOW VOLTAGE CONTROL
CH32	LOW VOLTAGE CONTROL
CH33	LOW VOLTAGE CONTROL
CH34	LOW VOLTAGE CONTROL
CH35	LOW VOLTAGE CONTROL
CH36	LOW VOLTAGE CONTROL
CH37	LOW VOLTAGE CONTROL
CH38	LOW VOLTAGE CONTROL
CH39	LOW VOLTAGE CONTROL
CH40	LOW VOLTAGE CONTROL
CH41	LOW VOLTAGE CONTROL
CH42	LOW VOLTAGE CONTROL
CH43	LOW VOLTAGE CONTROL
CH44	LOW VOLTAGE CONTROL
CH45	LOW VOLTAGE CONTROL
CH46	LOW VOLTAGE CONTROL
CH47	LOW VOLTAGE CONTROL
CH48	LOW VOLTAGE CONTROL
CH49	LOW VOLTAGE CONTROL
CH50	LOW VOLTAGE CONTROL

▲ ▲ LABELLED WIRES CORRECT IF NO OPTIONS USED. ▲ MOVE RED WIRE TO 200V TAP FOR 200V OPERATION ▲ RED (LIM.) BLACK (OIL) WHERE APPLICABLE

FACTORY WIRE	FIELD	OPTIONAL	COLOR CODE	WIRE	WIRE	WIRE	WIRE	WIRE
BLACK	---	---	YELLOW	Y	VIOLET	V	TAH	TAH
BROWN	---	---	GREEN	G	PURPLE	P	PK	PK
RED	---	---	BLUE	B	GRAY	GT	L	L
ORANGE	---	---	WHITE	W	SLATE	CS	CSB	CSB

BARCO MFG. CO.
 DWG. 4085-110 C
 DRN. CSB
 CHK./APP.:

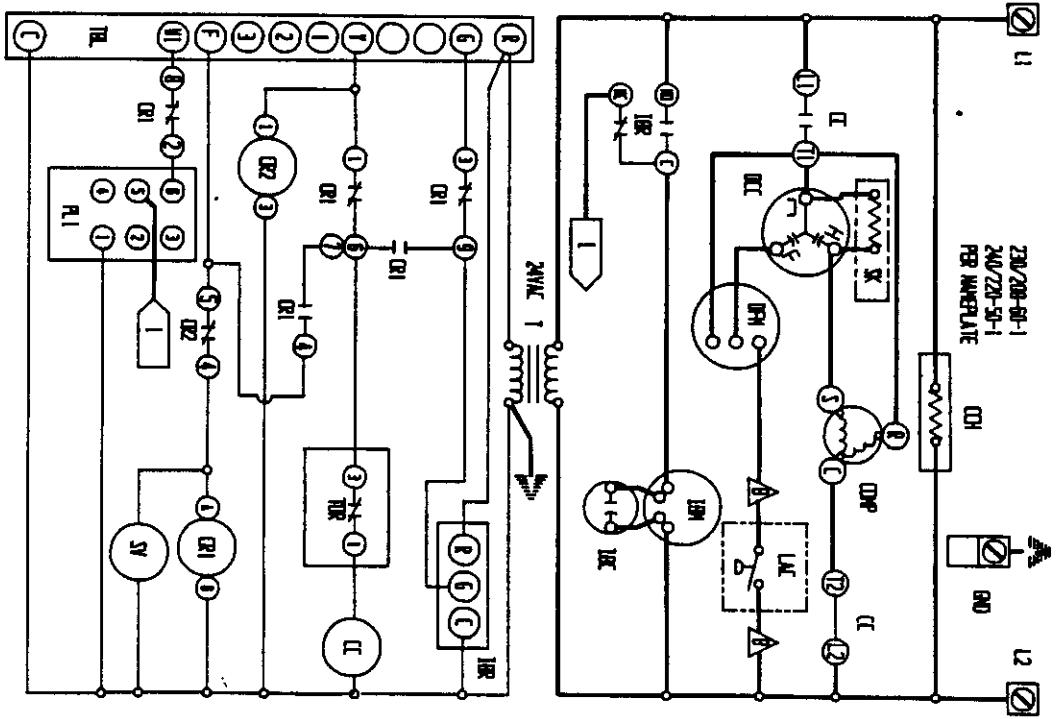
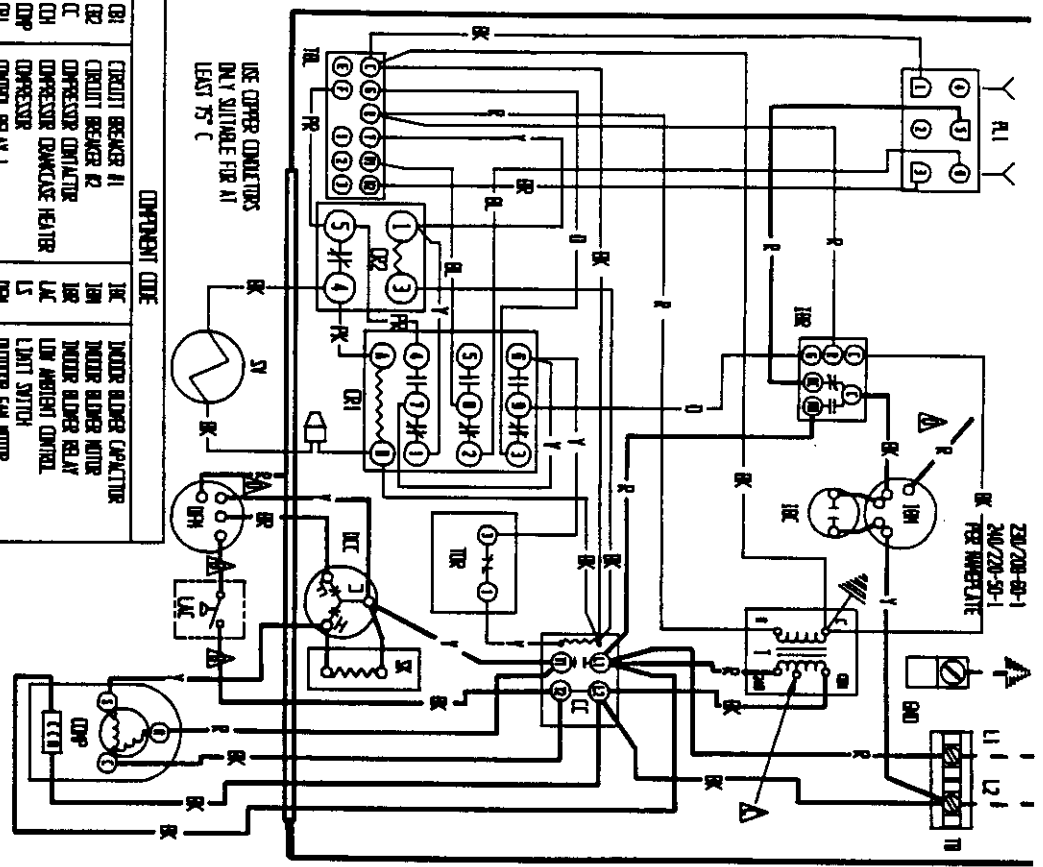

▲ LABELLED WIRES CONNECT IF NO OPTIONS USED.

▲ WIRE RED WIRE TO 208V TAP FOR 208V OPERATION

▲ RED (LOW) BLACK (HIGH) WIRE AVAILABLE

BLACK	BLACK	BLACK	BLACK	BLACK	BLACK	BLACK	BLACK	BLACK	BLACK
RED	RED	RED	RED	RED	RED	RED	RED	RED	RED
BLUE	BLUE	BLUE	BLUE	BLUE	BLUE	BLUE	BLUE	BLUE	BLUE
GREEN	GREEN	GREEN	GREEN	GREEN	GREEN	GREEN	GREEN	GREEN	GREEN
YELLOW	YELLOW	YELLOW	YELLOW	YELLOW	YELLOW	YELLOW	YELLOW	YELLOW	YELLOW
ORANGE	ORANGE	ORANGE	ORANGE	ORANGE	ORANGE	ORANGE	ORANGE	ORANGE	ORANGE
PINK	PINK	PINK	PINK	PINK	PINK	PINK	PINK	PINK	PINK
WHITE	WHITE	WHITE	WHITE	WHITE	WHITE	WHITE	WHITE	WHITE	WHITE
GREY	GREY	GREY	GREY	GREY	GREY	GREY	GREY	GREY	GREY

BARCO MFG. CO.
INC. 405-118 B
D.C.
OK./APR.

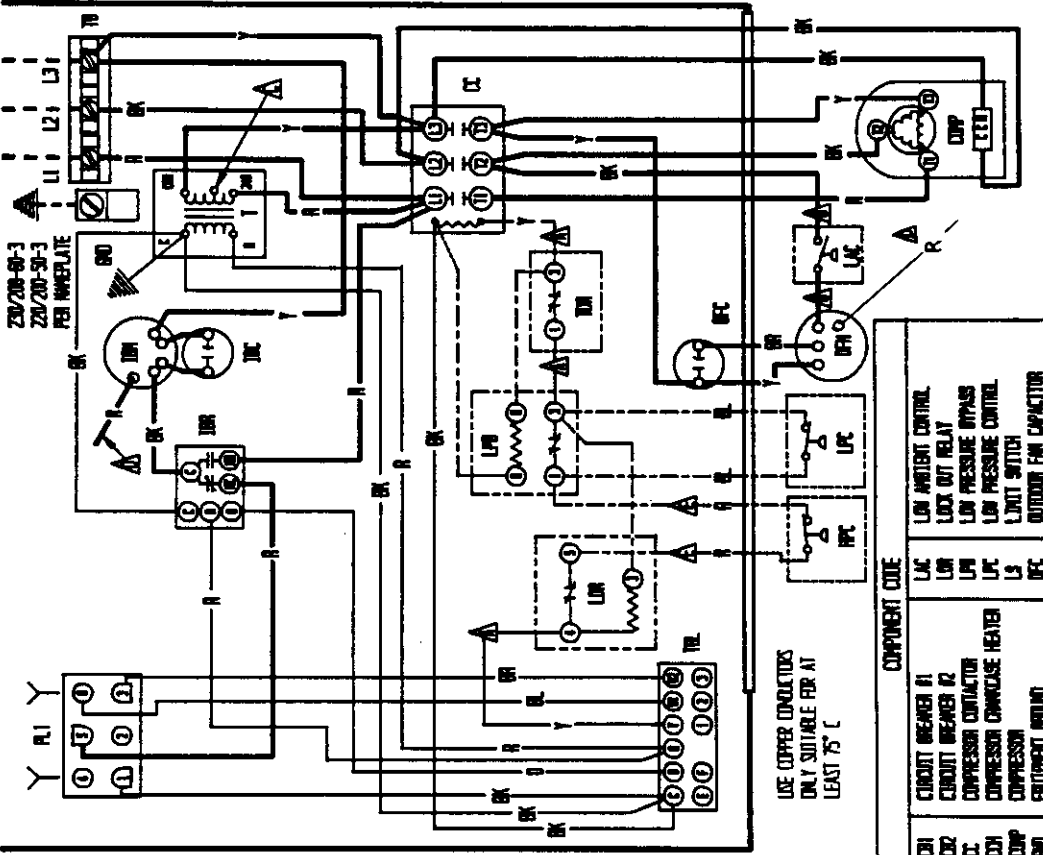
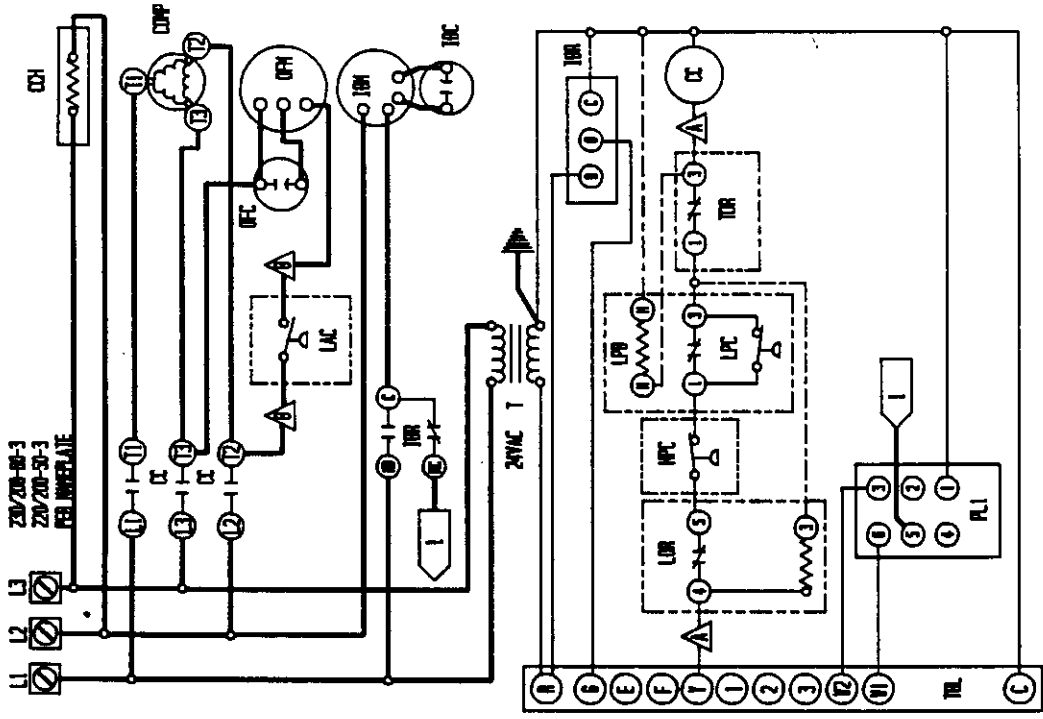

USE COPPER CONDUCTORS
ONLY SUITABLE FOR AT
LEAST 75 °C

COMPONENT CODE	COMPONENT CODE
C01	CIRCUIT BREAKER #1
C02	CIRCUIT BREAKER #2
C03	COMPRESSOR CONTACTOR
C04	COMPRESSOR COMPALUSE HEATER
C05	COMPRESSOR COMPALUSE HEATER
C06	EQUIPMENT GROUND
C07	HEAT STRIP #1
C08	HEAT STRIP #2
C09	HEATER CONTACTOR #1
C10	HEATER CONTACTOR #2
C11	HIGH PRESSURE CONTROL
C12	INDOOR BLOWER CAPACITOR
C13	INDOOR BLOWER MOTOR
C14	INDOOR BLOWER RELAY
C15	LOW AMBIENT CONTROL
C16	LOCK OUT RELAY
C17	LOW PRESSURE BYPASS
C18	LOW PRESSURE CONTROL
C19	LOW PRESSURE CONTROL
C20	LIMIT SWITCH
C21	OUTDOOR FAN CAPACITOR
C22	OUTDOOR FAN MOTOR
C23	PLUS #1
C24	START KIT
C25	TRANSFORMER
C26	TERMINAL BLOCK
C27	LOW VOLTAGE TERMINAL BLOCK
C28	TERMINAL CUTOFF
C29	TYPE DELAY RELAY

RED (UNLESS BLACK INDICATED) WHERE APPLICABLE

△ NINE RED WIRES TO ZONE TAP FOR ZONE OPERATION △ WHERE APPLICABLE

△ LABELLED WIRES CORRECT IF NO OPTIONS USED. △ UNLABELED WIRES CORRECT IF NO OPTIONS USED.

FACTORY NO.	FIELD	OPTIONAL
NON VOLUME	---	---
LOW VOLUME	---	---
EXCESSIVE	---	---

COLOR CODE	
BLACK	Y
BROWN	6
RED	R
ORANGE	V
YELLOW	Y
GREEN	(PA)
BLUE	BT
WHITE	(S)
VIOLET	V
PURPLE	PK
GRAY	L
SLATE	L
TAN	TAN
PINK	PINK
LAVENDER	LAVENDER

BARD MFC. CO.	
DWG.	4055-210 D
REV.	058
CHK./APPR.	

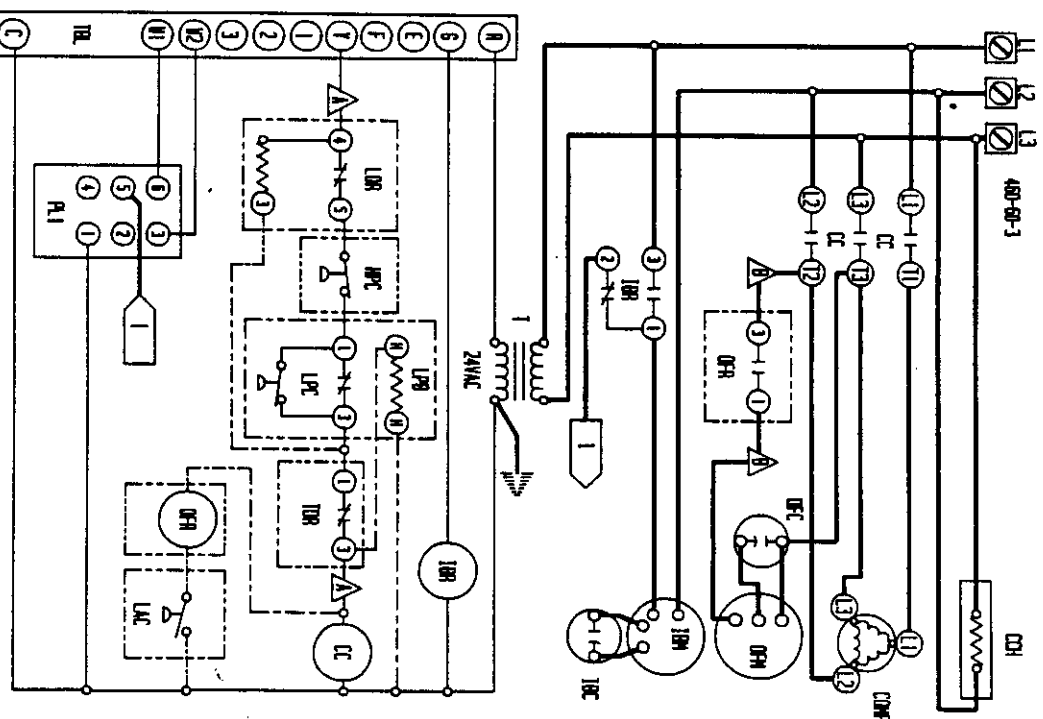
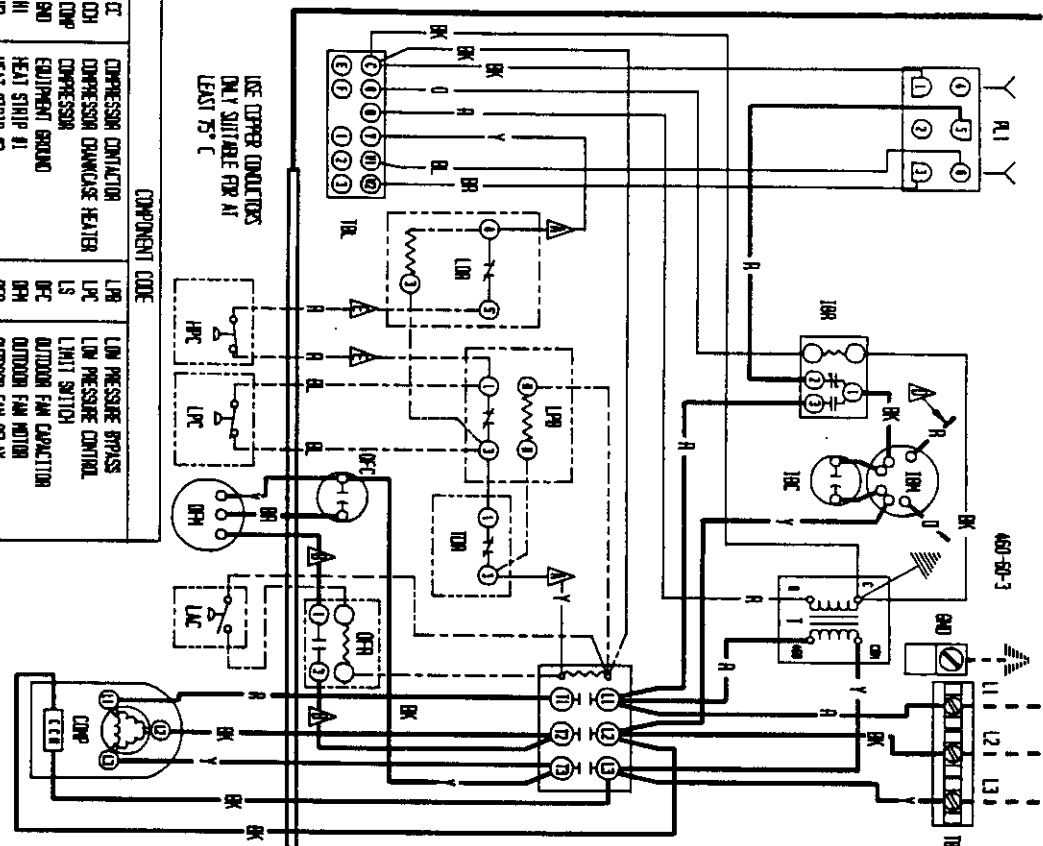

COMPONENT CODE

CI	COMPRESSOR CONTACTOR	LPR	LOW PRESSURE SWITCH
CO	COMPRESSOR	LPC	LOW PRESSURE CONTROL
SN	COMPRESSOR SQUAWK HEATER	LS	LIMIT SWITCH
SI	EQUIPMENT GROUND	OR	OUTDOOR FAN CAPACITOR
H1	HEAT STRIP #1	ORH	OUTDOOR FAN MOTOR
H2	HEAT STRIP #2	ORR	OUTDOOR FAN RELAY
HC1	HEATER CONTACTOR #1	PL	PLUG DISCONNECT
HC2	HEATER CONTACTOR #2	PLS	PLUG #1
HPC	HIGH PRESSURE CONTROL	TR	TRANSFORMER
IR	INDOOR BLOWER CAPACITOR	TRB	TERMINAL BLOCK
IRM	INDOOR BLOWER MOTOR	TRC	LOW VOLTAGE TERMINAL BLOCK
IRC	INDOOR BLOWER RELAY	TRD	THERMAL CUTOFF
LAC	LOW AMBIENT CONTROL	TRR	TIME RELAY RELAY
LOR	LOCK OUT RELAY		

▲ ▲ Labeled wires connect if no options used.

▲ AND ISOLATE. CONNECT RED WIRE TO TERMINAL 1 IF 1SR.

COLOR CODE		WIRE COLOR	
Y	YELLOW	Y	YELLOW
G	GREEN	G	GREEN
B	BLUE	B	BLUE
W	WHITE	W	WHITE
V	VIOLET	V	VIOLET
P	PURPLE	P	PURPLE
R	RED	R	RED
O	ORANGE	O	ORANGE
BR	BROWN	BR	BROWN
BL	BLACK	BL	BLACK

BARCO MFG. CO.
 ONE, 4025-310 C
 ONE, CBR
 ONE, APR.

USE COPPER CONDUCTORS
 ONLY SUITABLE FOR AT
 LEAST 75° C

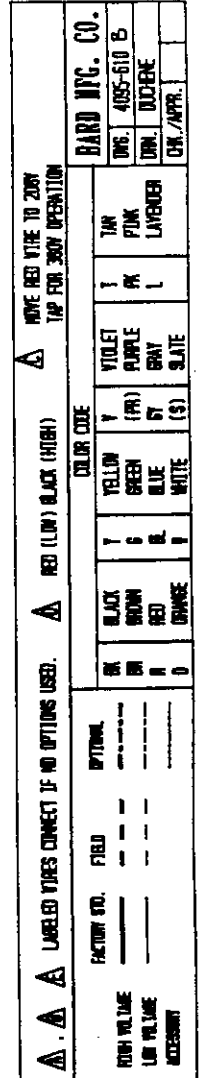
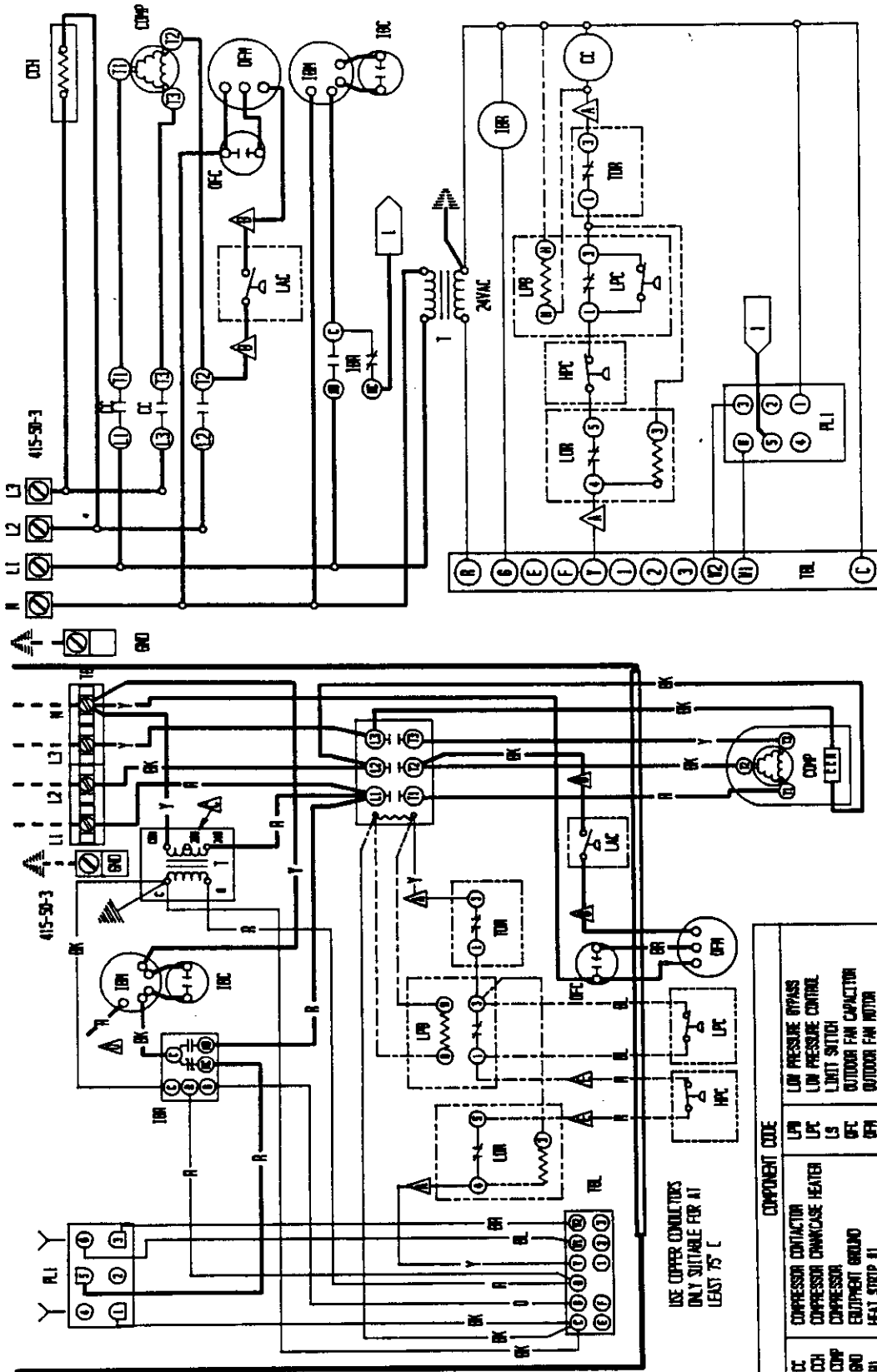

▲ ▲ Labeled wires connect if no options used. **▲** RED (LOW) BLACK (HIGH) **▲** MOVE RED WIRE TO 20RY TIP FOR 350V OPERATION

FACTORY W/O.		FIELD		OPTIONAL	
FORM VOLTAGE	---	---	---	---	---
LOW VOLTAGE	---	---	---	---	---
NECESSARY	---	---	---	---	---

BK	BLACK	Y	VIOLET	T	TAN
BR	BROWN	G	PURPLE	PK	PINK
R	RED	BL	GRAY	L	LAVENDER
O	ORANGE	W	SLATE		

COLOR CODE

BARCO MFG. CO.

ENG. 4085-610 B

DRW. BUCHE

CHK./APP. _____

USE COPPER CONDUCTORS ONLY SUITABLE FOR AT LEAST 75 °C

COMPONENT	CODE
COMPRESSOR CONTACTOR	LPC
COMPRESSOR COMPASS HEATER	LFC
COMPRESSOR	LS
EQUIPMENT GROUND	LAC
HEAT STRIP #1	GR
HEAT STRIP #2	GR
HEATER CONTACTOR #1	TR
HEATER CONTACTOR #2	TR
HIGH PRESSURE CONTROL	TR
INDOOR BLOWER CAPACITOR	TR
INDOOR BLOWER MOTOR	TR
INDOOR BLOWER RELAY	TR
LOW AMBIENT CONTROL	TR
LOCK OUT RELAY	TR
LOW PRESSURE BYPASS	TR
LOW PRESSURE CONTROL	TR
LOW PRESSURE SWITCH	TR
OUTDOOR FAN CAPACITOR	TR
OUTDOOR FAN MOTOR	TR
OUTDOOR FAN RELAY	TR
PULL OUT SWINET	TR
PLUS #1	TR
TRANSFORMER	TR
TERMINAL BLOCK	TR
LOW VOLTAGE TERMINAL BLOCK	TR
REVERSAL CUTOFF	TR
TIME DELAY RELAY	TR

