

INSTALLATION INSTRUCTIONS

WALL MOUNTED PACKAGE AIR CONDITIONERS

MODELS

30WA6

36WA6

COPYRIGHT APRIL, 1989
BARD MANUFACTURING COMPANY
BRYAN, OHIO

INDEX

Important	2
Shipping Damage	2
General	2
Installation	2
Duct Work	2
Filter	2
Fresh Air Intake	3
Wall Mounting	3
Wiring--Main Power	3
Fan Blade Setting Dimensions	4
Refrigerant Charge	4
Pressure Service Ports	5
Important Installer Note	5
Crankcase Heaters	5

INDEX OF FIGURES AND TABLES

Figure 1 1
Figure 2 4
Figure 3 5
Figure 4 6
Figure 5 5

Table 1 1
Table 2 4
Table 3 4
Table 4 5
Table 5 8

ELECTRICAL SPECIFICATIONS

TABLE 1

Model	Rated Volts & Phase	① Max. Unit Amps @ 240/208V	"N" VERSION (STD MODELS LESS CIRCUIT BREAKERS)						"C" VERSIONS (WITH CIRCUIT BREAKERS)								
			No. Field Power Circuit	Internal Fuses (CKTA)	① Max. Ext. Fuse or Circuit Breaker	Minimum Circuit Ampacity	② Field Power Wire Size	② Ground Wire Size	No. Field Power Ckts.	① Max. Ext. Fuse or Circuit Breaker		Minimum Circuit Ampacity		② Field Power Wire Size		② Ground Wire Size	
										CkTA	CktB	CkTA	CktB	CkTA	CktB	CkTA	CktB
30WA6-A00*	230/208	16.2/17.2	1	--	35	23	10	10	1	35	--	23	--	10	--	10	--
05*	1	23.0/20.3	1	--	35	29	10	10	1	35	--	29	--	10	--	10	--
08*		35.5/31	1	--	45	45	6	10	1	45	--	45	--	6	--	10	--
10*		43.8/38.4	1	--	60	55	4	10	1	60	--	55	--	4	--	10	--
15*		64.7/56.3	1	60/30	90	81	3	8	2	60	30	55	26	4	8	10	10
30WA6-B00*	230/208	15.4/15.4	1	--	30	19	12	10	1	30	--	19	--	12	--	10	--
09*	3	23.9/20.9	1	--	30	30	10	10	1	30	--	30	--	10	--	10	--
36WA6-A00*	230/208	20.7/24.2	1	--	45	30	10	10	1	45	--	30	--	10	--	10	--
05*	1	23.0/24.2	1	--	45	30	10	10	1	45	--	30	--	10	--	10	--
08*		35.5/31	1	--	45	45	6	10	1	45	--	45	--	6	--	10	--
10*		43.8/38.4	1	--	60	55	6	10	1	60	--	55	--	6	--	10	--
15*		64.7/56.3	1	60/30	90	81	3	8	2	60	30	55	26	4	10	10	10
36WA6-B00*	230/208	17.7/16.7	1	--	35	22	10	10	1	35	--	22	--	10	--	10	--
06*	3	17.7/16.7	1	--	35	22	10	10	1	35	--	22	--	10	--	10	--
09*		23.9/20.9	1	--	35	30	10	10	1	35	--	30	--	10	--	10	--
12*		31.1/27.2	1	--	40	40	8	10	1	40	--	40	--	8	--	10	--
15*		38.4/33.4	1	--	50	48	6	10	1	50	--	48	--	6	--	10	--
36WA6-C00*	460	9.5	1	--	15	15	14	14	1	15	--	15	--	14	--	14	--
09*	3	11.9	1	--	15	15	14	14	1	15	--	15	--	14	--	14	--
15*		19.1	1	--	25	24	10	10	1	25	--	24	--	10	--	10	--

* - N for standard models (less circuit breakers).

- C for models with circuit breakers.

① Maximum size of the time delay fuse or HACR type circuit breaker for protection of field wiring conductors. (Sizes 70 amp or greater are not HACR type).

② Based on 60 degree C copper wire.

FIGURE 1

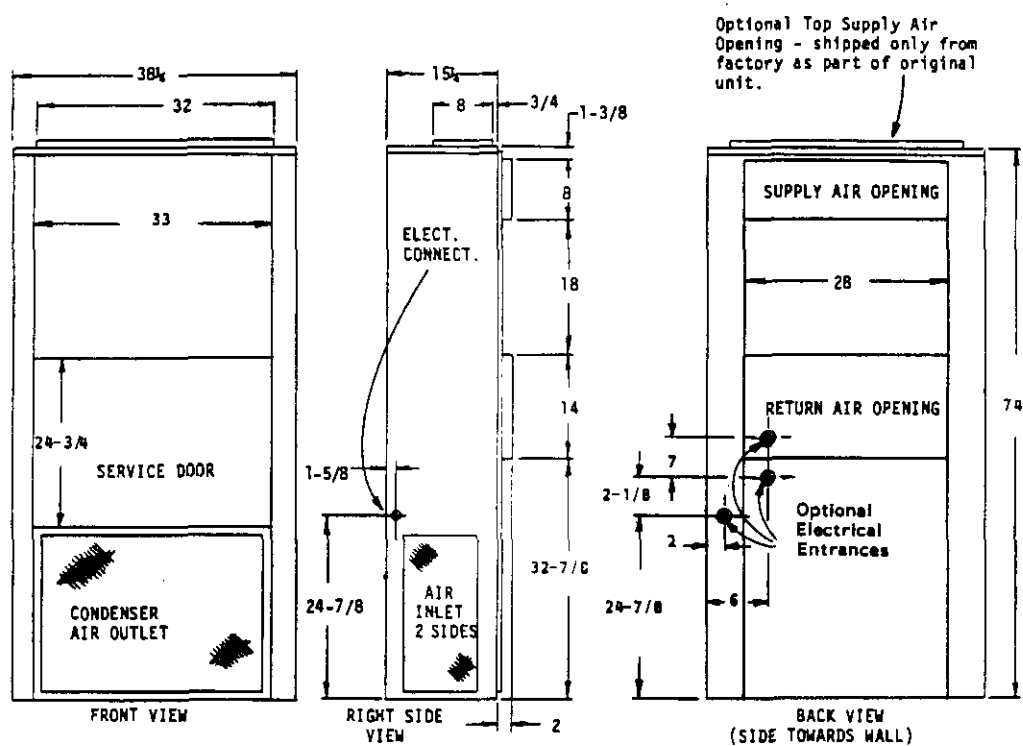

IMPORTANT

The equipment covered in this manual is to be installed by trained, experienced service and installation technicians. Any heat pump is more critical of proper operating, charge and an adequate duct system than a straight air conditioning unit. All duct work supply and return, must be properly sized for the design air flow requirement of the equipment. ACCA is an excellent guide to proper sizing. All duct work or portions thereof not in the conditioned space should be properly insulated in order to both conserve energy and prevent condensation or moisture damage.

SHIPPING DAMAGE

Upon receipt of equipment, the carton should be checked for external signs of shipping damage. If damage is found, the receiving party must contact the last carrier immediately, preferably in writing, requesting inspection by the carrier's agent.

GENERAL

The refrigerant system is completely assembled and charged. All internal wiring is complete.

The unit is designed for use with or without duct work. Flanges are provided for attaching the supply and return ducts.

These instructions explain the recommended method to install the air cooled self-contained unit and the electrical wiring connections to the unit.

These instructions and any instructions packaged with any separate equipment required to make up the entire air conditioning system should be carefully read before beginning the installation. Note particularly "Starting Procedure" and any tags and/or labels attached to the equipment.

While these instructions are intended as a general recommended guide, they do not supersede any national and/or local codes in any way. Authorities having jurisdiction should be consulted before the installation is made.

INSTALLATION

Size of unit for a proposed installation should be based on heat loss calculation made according to methods of Air Conditioning Contractors of America (ACCA). The air duct should be installed in accordance with the Standards of the National Fire Protection Association for the Installation of Air Conditioning and Ventilating systems of Other Than Residence Type, NFPA No. 90A, and Residence Type Warm Air Heating and Air Conditioning Systems, NFPA No. 90B. Where local regulations are at a variance with instructions, installer should adhere to local codes.

DUCT WORK

Design the duct work according to methods given by the Air Conditioning Contractors of America. When duct runs through unheated spaces, it should be insulated with a minimum of one inch of insulation. Use insulation with a vapor barrier on the outside of the insulation. Flexible joints should be used to connect the duct work to the equipment in order to keep the noise transmission to a minimum.

A one-inch clearance to combustible material for the first three feet of duct attached to the outlet air frame is required see page 7 for further details.

FILTER

A one inch throwaway filter is supplied with each unit. The filter slides into position making it easy to service. This filter can be serviced from the outside by removing the service door.

FRESH AIR INTAKE

All units are built with a fresh air inlet hole punched in the service panel. The fresh air damper assembly is shipped with each unit, and must be attached at the installation site. See Figure 4 for typical installation procedure.

The fresh air damper assembly is standard equipment with the unit because of the variety of state or local codes requiring fresh air capability.

All capacity, efficiency and cost of operation information as required for Department of Energy "Energyguide" Fact Sheets is based upon the fresh air blank-off plate in place and is recommended for maximum energy efficiency.

The blank-off plate is available upon request from the factory and is installed in place of the fresh air damper shipped with each unit.

WALL MOUNTING

1. Two holes, for the supply and return air openings must be cut through the wall as shown in Figure 5.
2. On wood-frame walls, the wall construction must be strong and rigid enough to carry the weight of the unit without transmitting any unit vibration. **WARNING:** Fire hazard can result if one inch clearance to combustible material for supply air duct is not maintained. See Figure 5.
3. Concrete block walls must be thoroughly inspected to insure that they are capable of carrying the weight of the installing unit.
4. Ducts through the walls must be insulated and all joints taped or sealed to prevent air or moisture entering the wall cavity.
5. Some installations may not require any return air duct. It is recommended that on this type of installation that a filter grille be located in the wall. Filters must be of sufficient size to allow a maximum velocity of 400 FPM.

NOTE: If no return air duct is used, applicable installation codes may limit this cabinet to installation only in a single story structure.

WIRING--MAIN POWER

Refer to the unit rating plate for wire sizing information and maximum fuse or "HACR Type" circuit breaker size. Each outdoor unit is marked with a "Minimum Circuit Ampacity". This means that the field wiring used must be sized to carry that amount of current. Depending on the installed KW of electric heat, there may be two field power circuits required. If this is the case, the unit serial plate will so indicate. Some models are suitable only for connection with copper wire, while others can be wired with either copper or aluminum wire. Each unit and/or wiring diagram will be marked "Use Copper Conductors Only" or "Use Copper or Aluminum Conductors." These instructions **MUST BE** adhered to. Refer to the National Electrical Code for complete current carrying capacity data on the various insulation grades of wiring material.

The electrical data lists fuse and wire sizes (60 degree C copper) for all models, including the most commonly used heater sizes. Also shown are the number of field power circuits required for the various models with heaters.

The unit rating plate lists a "Maximum Time Delay Relay Fuse" or "HACR Type" circuit breaker that is to be used with the equipment. The correct size must be used for proper circuit protection and also to assure that there will be no nuisance tripping due to the momentary high starting current of the compressor motor.

Field conduit connections must be to the control box and not terminate at the cabinet.

FAN BLADE SETTING DIMENSIONS

Shown in the drawing below are the correct fan blade setting dimensions for proper air delivery across the outdoor coil.

Any service work requiring removal or adjustment in the fan and/or motor area will require that the dimensions below be checked and the blade adjusted in or out on the motor shaft accordingly.

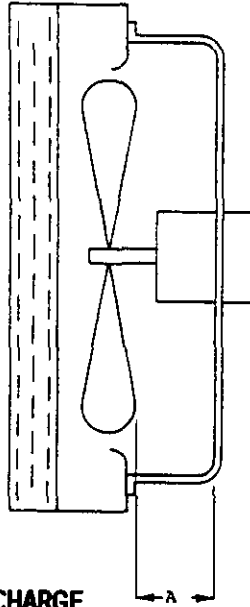

FIGURE 2

Model	Dimension A
30WA6	1/2
36WA6	1/4

REFRIGERANT CHARGE

The correct system R-22 charge is shown on the unit rating plate. Optimum unit performance will occur with a refrigerant charge resulting in a suction line temperature (6" from compressor) as shown in the following table:

TABLE 2

Model	Rated Airflow	95 Degree F OD Temperature	82 Degree F OD Temperature
30WA6	1140	56 - 58	66 - 68
36WA6	1185	44 - 47	57 - 59

The above suction line temperatures are based upon 80 degree F dry bulb/67 degree F wet bulb (50 percent R.H.) temperature and rated airflow across the evaporator during cooling cycle.

TABLE 3

INDOOR BLOWER PERFORMANCE CFM--DRY COIL WITH FILTER		
B.S.P. Inches H2O	Models 30WA6-36WA6	
	Low	High
.0	970	1435
.1	925	1350
.2	900	1260
.3		1150
.4		1050
.5		940

PRESSURE SERVICE PORTS

High and low pressure service ports are installed on all units so that the system operating pressures can be observed. Pressure curves can be found later in the manual covering all models on both cooling and heating cycles. It is imperative to match the correct pressure curve to the unit by model number.

TABLE 4

Model	Rated CFM*	Rated ESP*	Recommended Airflow Range
30WA6	1140	.17	930 - 1300
36WA6	1185	.15	930 - 1350

*Rated CFM and ESP on high speed tap.

IMPORTANT INSTALLER NOTE

For improved start-up performance, wash the indoor coil with a dishwasher detergent.

CRANKCASE HEATERS

All units are provided with some form of compressor crankcase heat. Some single phase units utilize the compressor motor start winding in series with a portion of the run capacitor to generate heat within the compressor shell to prevent liquid refrigerant migration.

Some three phase units utilize a wraparound type of crankcase heater that warms the compressor oil from the outside.

Some single and three phase models have an insertion well-type heater located in the lower section of the compressor housing. This is a self-regulating type heater that draws only enough power to maintain the compressor at a safe temperature.

Some form of crankcase heat is essential to prevent liquid refrigerant from migrating to the compressor, causing oil pump out on compressor start-up and possible valve failure due to compressing a liquid.

Refer to unit wiring diagram to find exact type of crankcase heater used.

The decal in Figure 3 is affixed to all outdoor units detailing start-up procedure. This is very important. Please read carefully.

FIGURE 3

IMPORTANT

THESE PROCEDURES MUST BE FOLLOWED AT INITIAL START-UP AND AT ANY TIME POWER HAS BEEN REMOVED FOR 12 HOURS OR LONGER.

TO PREVENT COMPRESSOR DAMAGE WHICH MAY RESULT FROM THE PRESENCE OF LIQUID REFRIGERANT IN THE COMPRESSOR CRANKCASE

1. MAKE CERTAIN THE ROOM THERMOSTAT IS IN THE "OFF" POSITION. (THE COMPRESSOR IS NOT TO OPERATE).
2. APPLY POWER BY CLOSING THE SYSTEM DISCONNECT SWITCH THIS ENERGIZES THE COMPRESSOR HEATER WHICH EVAPORATES THE LIQUID REFRIGERANT IN THE CRANKCASE.
3. ALLOW 4 HOURS OR 60 MINUTES PER POUND OF REFRIGERANT IN THE SYSTEM AS NOTED ON THE UNIT RATING PLATE. WHICHEVER IS GREATER.
4. AFTER PROPERLY ELAPSED TIME THE THERMOSTAT MAY BE SET TO OPERATE THE COMPRESSOR.
5. EXCEPT AS REQUIRED FOR SAFETY WHILE SERVICING — DO NOT OPEN SYSTEM DISCONNECT SWITCH.

7961-061

FIGURE 4

UNIT MODELS

20WA
24WA
18WH
24WH

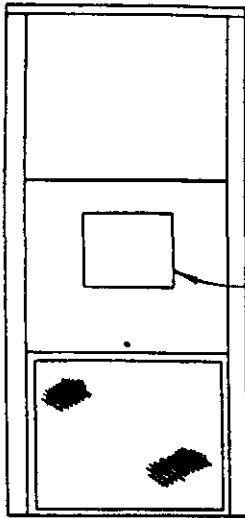

Model FAD10
Fresh Air Cover
With Adjustable
Damper

UNIT MODELS

30WA
36WA
36WH
42WA
49WA
48WH
45WH
60WH
60WA

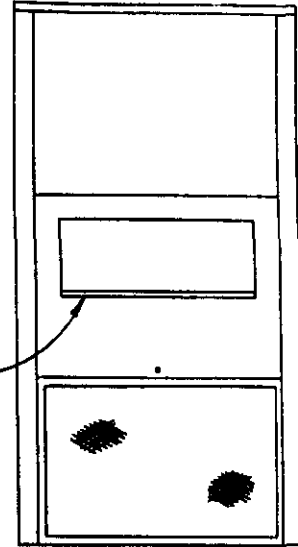

MODEL PAD25
Fresh Air Cover
With Adjustable
Damper

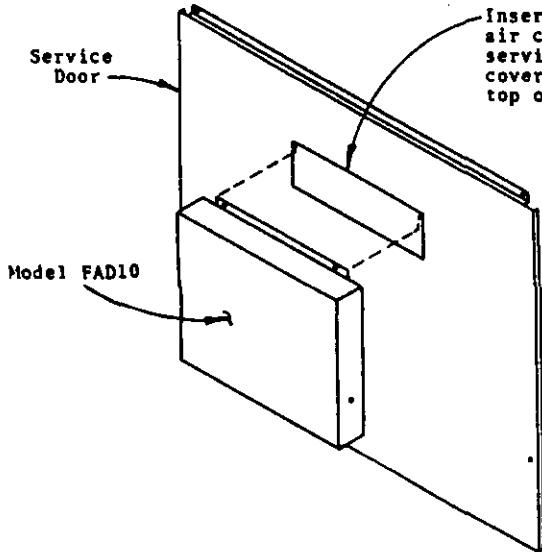

Service
Door

Model FAD10

Insert top flange of fresh
air cover into opening in
service door and push top of
cover assembly all the way to
top of opening.

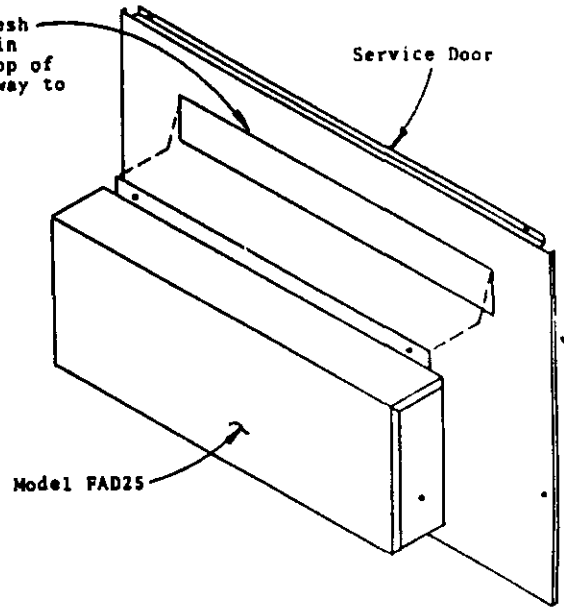

Service Door

Model FAD25

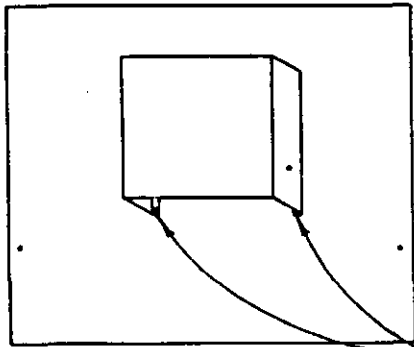

Secure bottom of
Fresh Air Cover Assembly
with two screws.

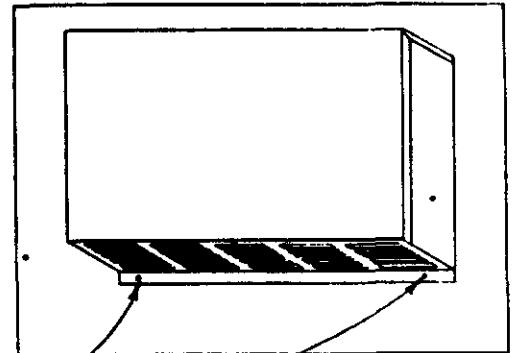

RIGHT SIDE VIEW

FIGURE 5

WALL VIEW

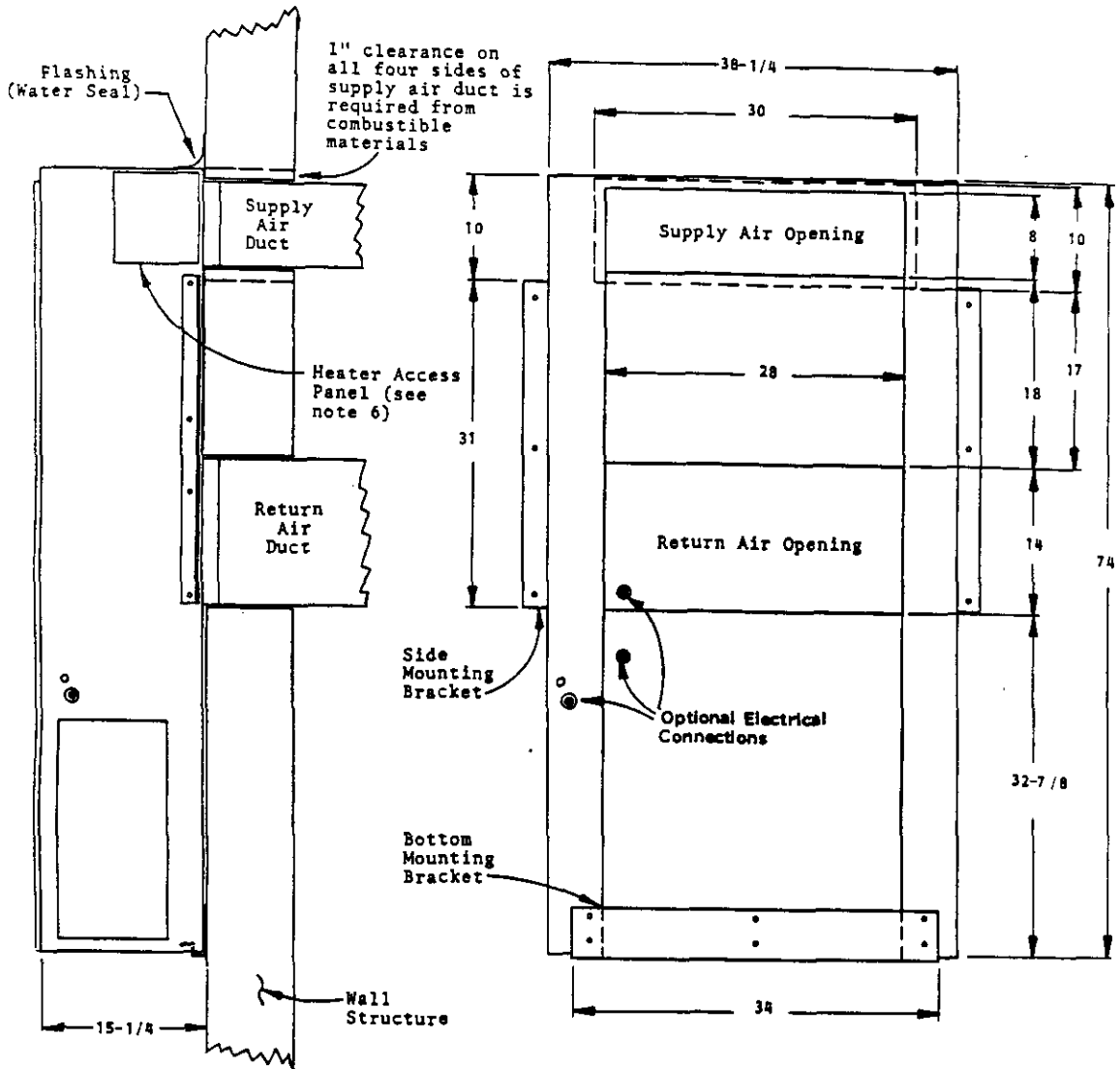

MOUNTING INSTRUCTIONS

1. These units are secured by wall mounting brackets which secure the unit to the outside wall surface at both sides and at the bottom.
2. The unit itself is suitable for "0" inch clearance, but the supply air duct flange and the first three feet of supply air duct require 1 inch clearance to combustible material. If combustible wall, use 30" x 10" dimensions for sizing, if non-combustible, use 28" x 8" dimensions.

WARNING: Failure to provide the one inch clearance for the first three feet between the supply duct and a combustible surface can result in fire.

3. After the wall opening positions have been selected, lay out the position for the bottom and side brackets. Fasten the brackets securely to the wall (type of fasteners will depend on wall construction).
4. Be sure to observe the 10" dimension when attaching the side brackets. This will assure that no screws are driven into the unit sides damaging any internal parts. One-half inch sheet metal screws are recommended.
5. For additional mounting rigidity, the return air and supply air (depending upon wall construction) frames or collars can be drilled and screwed or welded to the structural wall itself. Be sure to observe required clearance if combustible wall.
6. Maintain 30 inches minimum clearance on right side of unit to allow access to heat strip and control panel.

COOLING

TABLE 5

Air Temperature Entering Outdoor Coil Degree F

Model	Return Air Temperature	Pressure	°	°	°	°	°	°	°	°	°
			75	80	85	90	95	100	105	110	115
30WA6	75 deg. DB	Low Side	65	68	69	71	73	76	78	79	81
	62 deg. WB	High Side	206	221	238	255	271	287	304	320	336
	80 deg. DB	Low Side	69	73	74	76	78	81	83	85	87
	67 deg. WB	High Side	211	227	244	262	278	294	312	328	345
	85 deg. DB	Low Side	71	76	77	79	81	84	86	88	90
	72 deg. WB	High Side	227	244	262	282	299	316	335	353	371
36WA6	75 deg. DB	Low Side	61	63	65	66	68	70	73	74	76
	62 deg. WB	High Side	228	244	261	276	293	308	324	348	357
	80 deg. DB	Low Side	65	67	69	71	73	75	78	79	81
	67 deg. WB	High Side	234	250	268	283	300	316	332	357	366
	85 deg. DB	Low Side	67	69	71	73	76	78	81	82	84
	72 deg. WB	High Side	251	259	277	293	311	327	344	369	379

Low side pressure \pm 2 PSIG
 High side pressure \pm 5 PSIG

Tables are based upon rated CFM (airflow) across the evaporator coil and should be found under section titled "Refrigerant Charge" elsewhere in manual. If there is any doubt as to correct operating charge being in the system, the charge should be removed, system evacuated, and recharged to serial plate instructions.

BLOWER ASSEMBLY

Date: 05/04/89

Dwg. No.	Part No.	Description	9	9
			0	0
			0	0
			0	0
			3	7
			9	0
1	5152-051	Housing, Wheel and Cutoff (CW)	X	X
2	5152-052	Housing, Wheel and Cutoff	X	X
3	8105-029	Blower Motor (230/208)	X	
3	8105-033	Blower Motor (460)		X
4	8552-002	Capacitor	X	X
5	8200-031	Motor Mount	X	X
6	5451-011	Grommets	6	6
7	104-505	Back Brace	X	X
8	104-001	Side Angle	2	2
9	102-300	Front Brace	X	X

WZ21/PARTSLIST/TEXTLIB

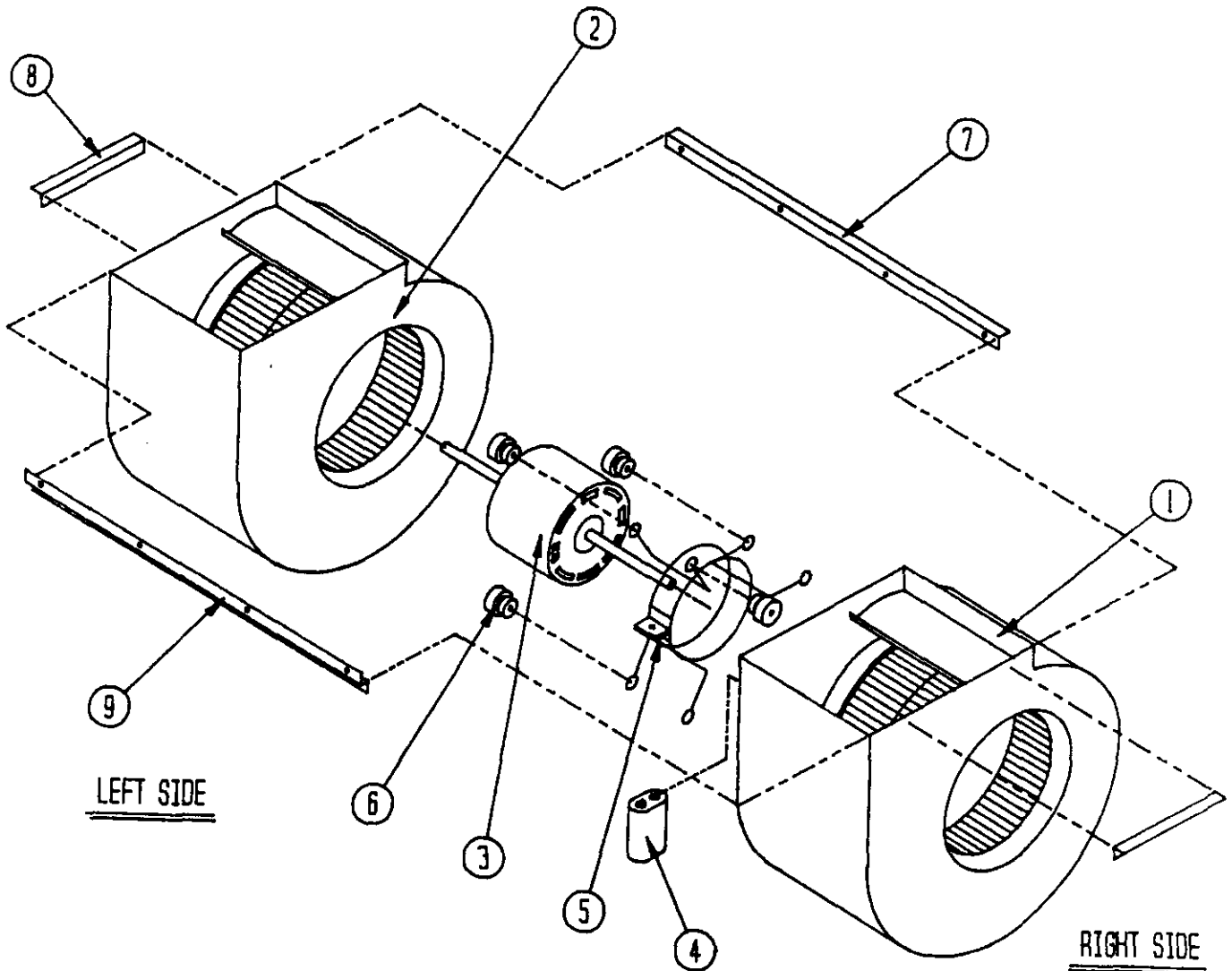

CABINET COMPONENTS
30WA6, 36WA7

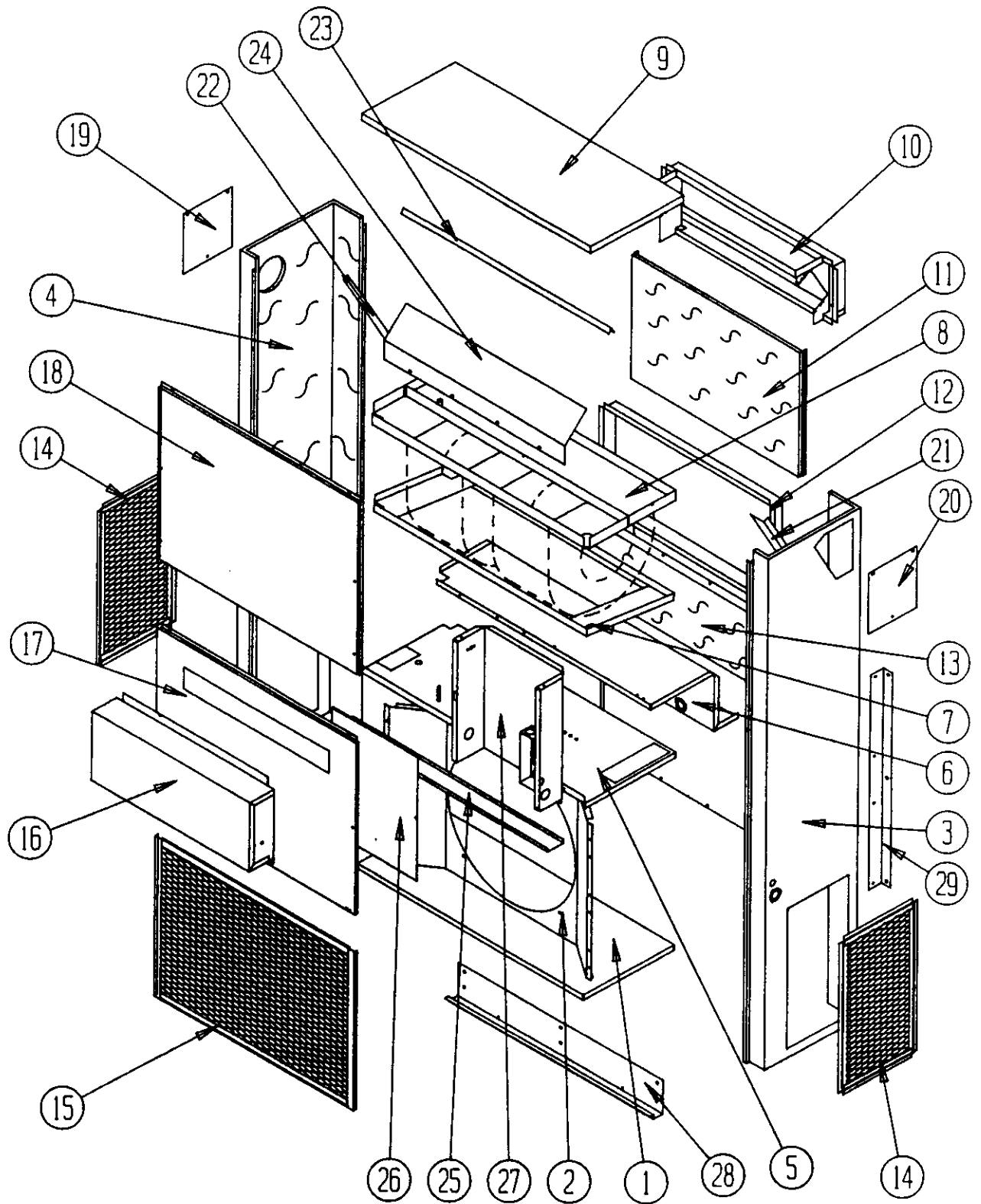

CABINET COMPONENTS
30WA6, 36WA6, 30WB6, 36WB7

Date: 05/04/89

Item	Part No.	Description	U S A G E
1	126-003	Lower Base	X
2	124-002	Fan Shroud	X
3	501-164	Right Side	X
4	501-165	Left Side	X
5	127-098	Compressor Base	X
6	520-097	Compressor Partition	X
7	131-002	Filter Tray	X
8	521-004	Blower Addition/Drain Pan Assembly	X
9	506-095	Top	X
10	111-017	Outlet Airframe Assembly	X
11	508-056	Upper Back	X
12	111-018	Inlet Air Frame Assembly	X
13	508-057	Lower Back	X
14	119-004	Side Grille	2
15	119-003	Condenser Grille	X
16	FAD25	Fresh Air Damper Assembly	X
17	552-107	Service Door	X
18	514-046	Upper Front	X
19	542Y004	Left Side Cover Plate	X
20	542X004	Right Side Cover Plate	X
21	141-006	Right Evaporator Support	X
22	141-007	Left Evaporator Support	X
23	136-093	Evaporator Fill Plate	X
24	134-008	Air Baffle	X
25	136-002	Condenser Coil Spacer	X
26	Cntrl.Cvr.	See Control Panel Assembly Drawing and Parts List	X
27	Cntrl.Pnl. Assembly	See Control Panel Assembly Drawing and Parts List	X
28	112-006	Bottom Mounting Bracket	X
29	112-002	Side Mounting Bracket	2

WZ28/PARTSLIST/TEXTLIB

FUNCTIONAL COMPONENTS
30WA6

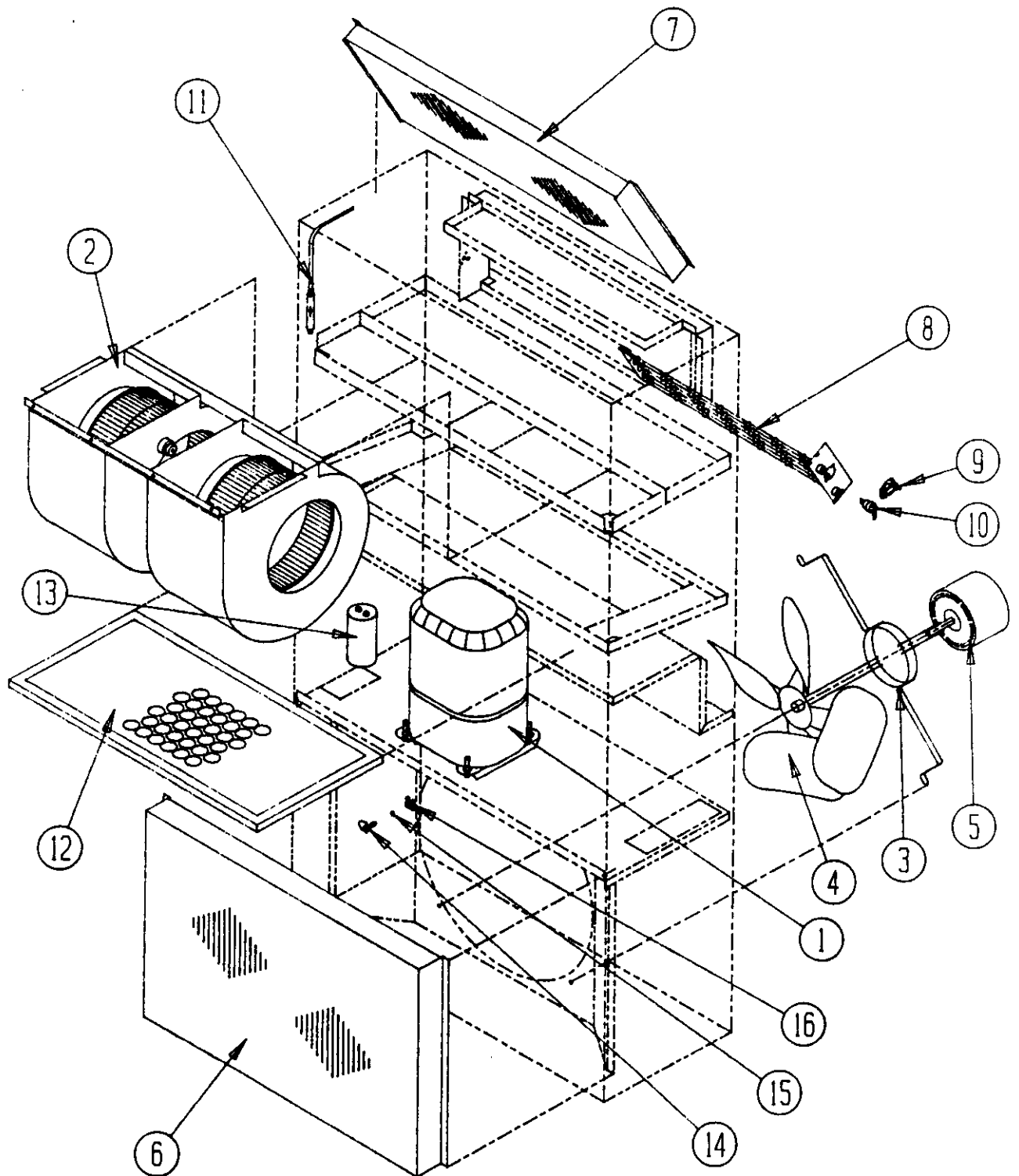

FUNCTIONAL COMPONENTS
30WA6

Date: 05/08/89

Dwg. No.	Part No.	Description	3 O W A 6 A O O N, C	3 O W A 6 A O 5 N, C	3 O W A 6 A O 8 N, C	3 O W A 6 A O 0 N, C	3 O W A 6 A 1 5 N, C	3 O W A 6 B O 0 N, C	3 O W A 6 B O 9 N, C
1	8000-099	Compressor H23B283ABCA	X	X	X	X	X		
1	8000-053	Compressor CRG3-0250-TF5						X	X
2	900-039	Blower Assembly (Complete)	X	X	X	X	X	X	X
3	8200-001	Motor Mount (Condenser)	X	X	X	X	X	X	X
4	5151-032	Fan Blade	X	X	X	X	X	X	X
5	8103-016	Condenser Motor	X	X	X	X	X	X	X
6	5051-035	Condenser Coil	X	X	X	X	X	X	X
7	5060-037	Evaporator Coil	X	X	X	X	X	X	X
8	8604-089	Heat Strip		X					
8	8604-090	Heat Strip			X				
8	8604-091	Heat Strip				X			
8	8604-047	Heat Strip					X		
8	8604-048	Heat Strip							X
9	8402-031	Limit Control		X	X	X	X		X
10	8402-032	Thermal Cut-Off		X	2	2	3		2
11	800-0072	Cooling Capillary Assembly	X	X	X	X	X	X	X
12	7004-008	Air Filter	X	X	X	X	X	X	X
13	8552-032	Compressor Capacitor	X	X	X	X	X		
14	1171-019	1/4 Turn Fastener	X	X	X	X	X	X	X
15	1171-021	1/4 Turn Fastener Retainer	X	X	X	X	X	X	X
16	1171-020	1/4 Turn Fastener Receptacle	X	X	X	X	X	X	X

WZ33/PARTSLIST/TEXTLIB

FUNCTIONAL COMPONENTS
36WA6

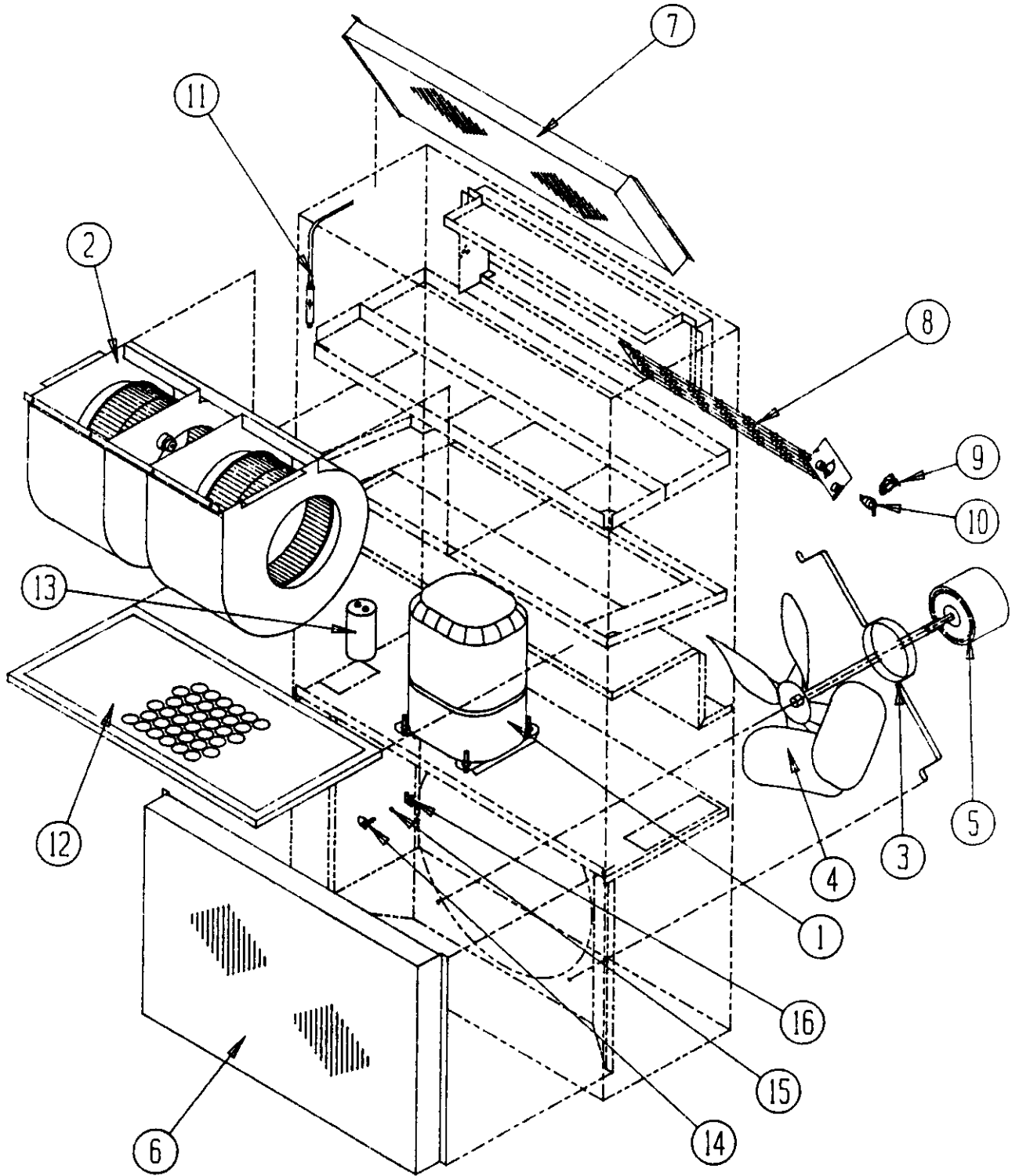

FUNCTIONAL COMPONENTS
36WA6

Date: 05/08/89

Dwg. No.	Part No.	Description	3 6 W A 6 A O O N, C	3 6 W A 6 A O 5 N, C	3 6 W A 6 A O 8 N, C	3 6 W A 6 A O 1 N, C	3 6 W A 6 A O 5 N, C	3 6 W A 6 B O 0 N, C	3 6 W A 6 B O 6 N, C	3 6 W A 6 B O 9 N, C	3 6 W A 6 B O 2 N, C	3 6 W A 6 B O 5 N, C	3 6 W A 6 C O 0 N, C	3 6 W A 6 C O 9 N, C	3 6 W A 6 C O 1 N, C	
1	8000-058	Compressor CRJ3-0300-PFV	X	X	X	X	X									
1	8000-059	Compressor CRJ3-0300-TF5						X	X	X	X	X				
1	8000-060	Compressor CRJ3-0300-TFD											X	X	X	
2	900-039	Blower Assembly (Complete)	X	X	X	X	X	X	X	X	X	X				
2	900-070	Blower Assembly (Complete)											X	X	X	
3	8200-001	Motor Mount (Condenser)	X	X	X	X	X	X	X	X	X	X	X	X	X	
4	5151-032	Fan Blade	X	X	X	X	X	X	X	X	X	X	X	X	X	
5	8103-019	Condenser Motor	X	X	X	X	X	X	X	X	X	X				
5	8103-014	Condenser Motor											X	X	X	
6	5051-035	Condenser Coil	X	X	X	X	X	X	X	X	X	X	X	X	X	
7	5060-037	Evaporator Coil	X	X	X	X	X	X	X	X	X	X	X	X	X	
8	8604-089	Heat Strip		X												
8	8604-090	Heat Strip			X											
8	8604-091	Heat Strip				X										
8	8604-047	Heat Strip					X					X				
8	8604-049	Heat Strip						X								
8	8604-048	Heat Strip							X							
8	8604-046	Heat Strip								X						
8	8604-072	Heat Strip												X	X	
8	8604-079	Heat Strip													X	
9	8402-031	Limit Control		X	X	X	X		X	X	X	X				
9	8402-060	Limit Control												X	X	
10	8402-032	Thermal Cut-Off		X	2	2	3		2	2	3	3				
10	8402-059	Thermal Cut-Off													2	4
11	800-0070	Cooling Capillary Assembly	X	X	X	X	X	X	X	X	X	X	X	X	X	
12	7004-008	Air Filter	X	X	X	X	X	X	X	X	X	X	X	X	X	
13	8552-028	Compressor Capacitor	X	X	X	X	X									
14	1171-019	1/4 Turn Fastener	X	X	X	X	X	X	X	X	X	X	X	X	X	
15	1171-021	1/4 Turn Fastener Retainer	X	X	X	X	X	X	X	X	X	X	X	X	X	
16	1171-020	1/4 Turn Fastener Receptacle	X	X	X	X	X	X	X	X	X	X	X	X	X	

WZ34/PARTSLIST/TEXTLIB

CONTROL PANEL
30WA6
WITHOUT CIRCUIT BREAKER

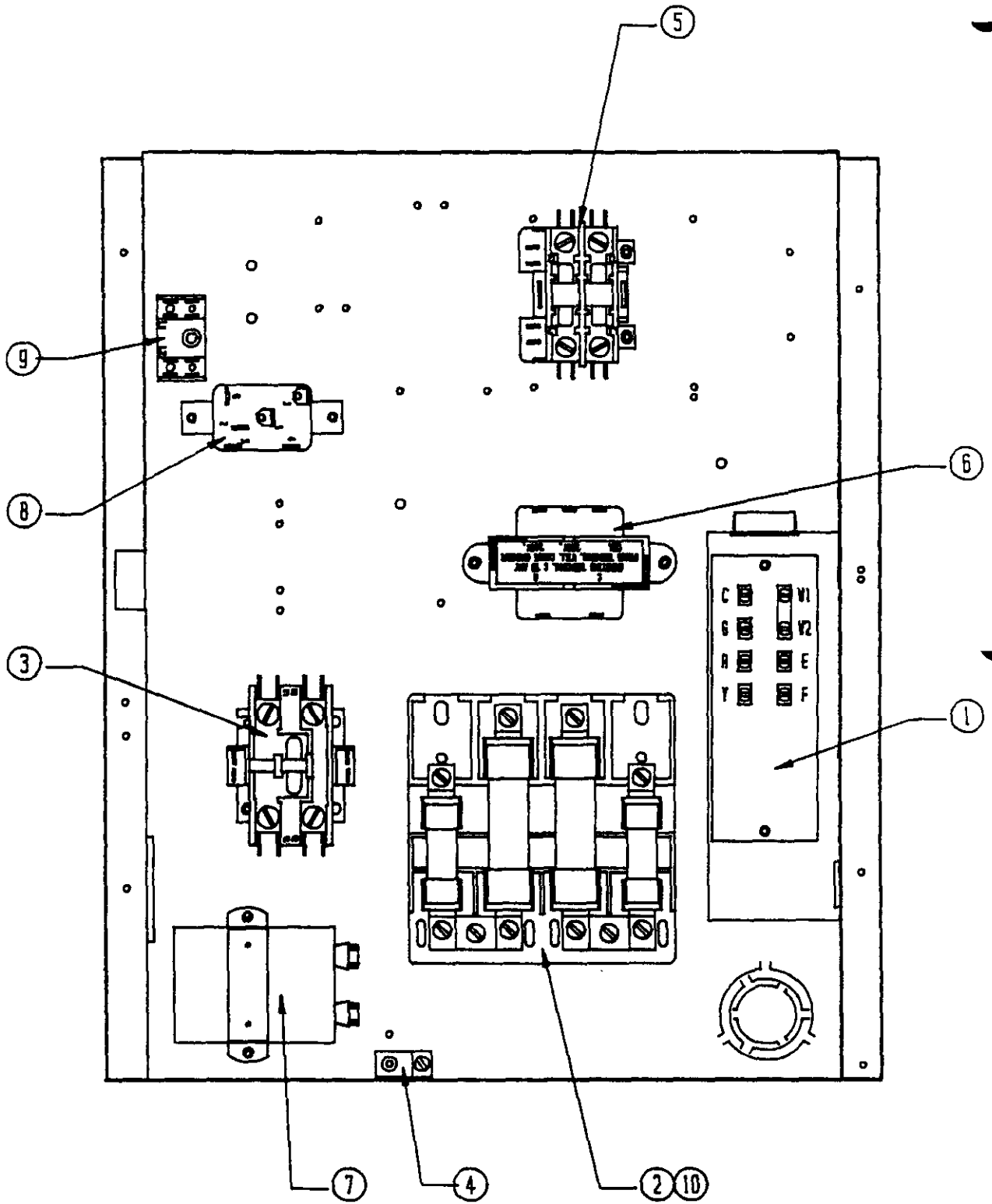

30-36 WA

CONTROL PANEL
30WA6
WITHOUT CIRCUIT BREAKERS

Page:
Date: 05/08/89

Dwg. No.	Part No.	Description	3	3	3	3	3	3	3
			0	0	0	0	0	0	0
			W	W	W	W	W	W	W
			A	A	A	A	A	A	A
			6	6	6	6	6	6	6
			A	A	A	A	A	B	B
			0	0	0	1	1	0	0
			0	5	8	0	5	0	9
			N	N	N	N	N	N	N
1	8607-018	Low Voltage Terminal Strip	X	X	X	X	X	X	X
2	8607-013	Terminal Block		X	X	X			
2	8607-014	Terminal Block							X
2	8614-017	Fuse Block					X		
3	8401-007	Compressor Contactor	X	X	X	X	X		
3	8401-002	Compressor Contactor						X	X
4	8611-006	Ground Terminal	X	X	X	X	X	X	X
5	8401-006	Heat Contactor		X	X	X	2		X
6	8407-034	Transformer	X	X	X	X	X	X	X
7	8552-002	Condenser Motor Capacitor	X	X	X	X	X	X	X
8	8201-009	Blower Relay	X	X	X	X	X	X	X
	4008-110	Wiring Diagram	X						
	4008-120	Wiring Diagram		X					
	4008-130	Wiring Diagram			X	X			
	4008-140	Wiring Diagram					X		
	4008-210	Wiring Diagram						X	
	4008-220	Wiring Diagram							X
	132-003	Control Panel Cover	X	X	X	X		X	X
	133-036	Control Panel Cover					X		

WZ29/PARTSLIST/TEXTLIB

CONTROL PANEL
30WA6
WITH CIRCUIT BREAKER

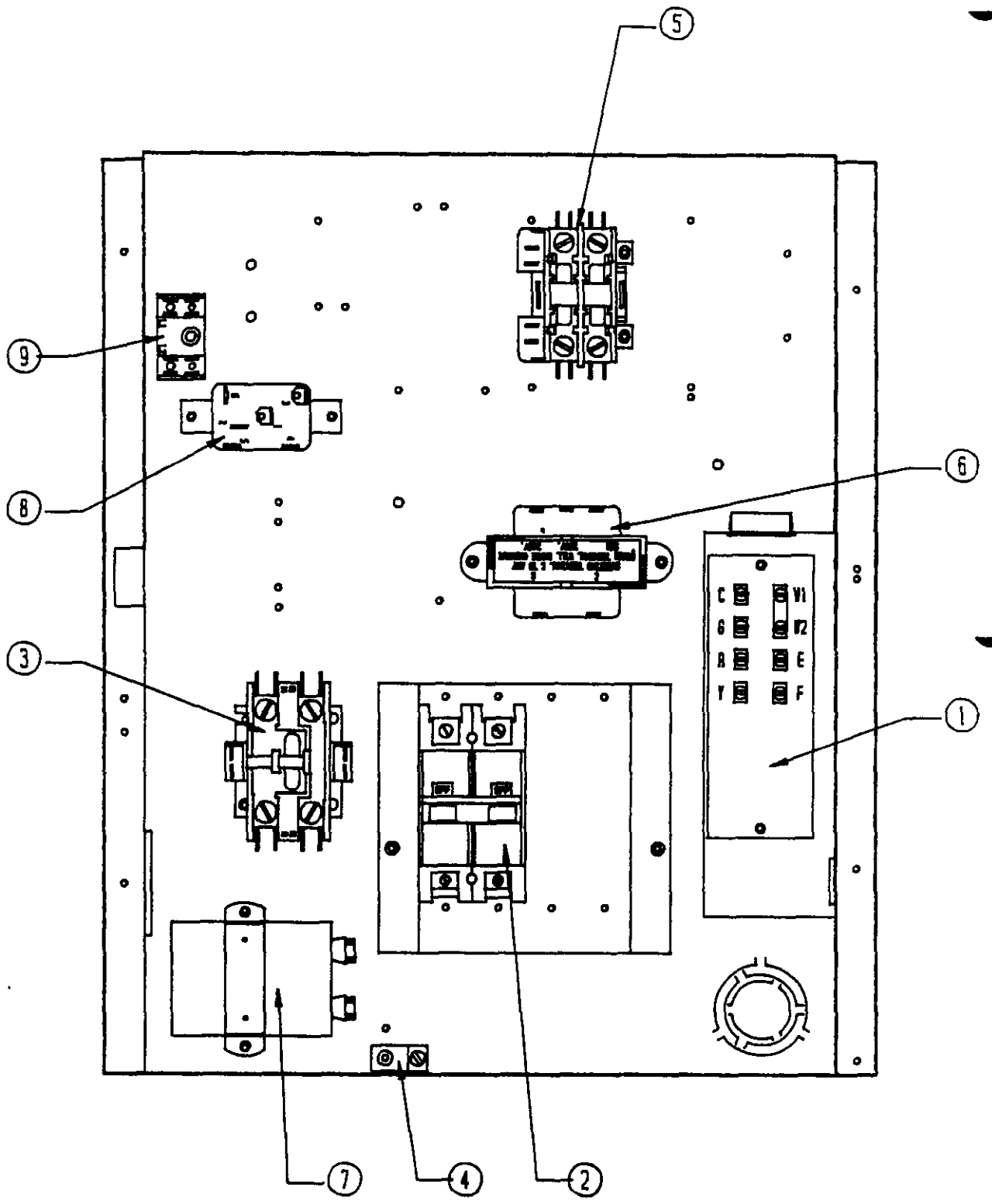

30-36 WA

CONTROL PANEL
30WA6
WITH CIRCUIT BREAKER

Date: 05/08/89

Dwg. No.	Part No.	Description	3	3	3	3	3	3	3
			O	O	O	O	O	O	O
			A	A	A	A	A	A	A
			6	6	6	6	6	6	6
			A	A	A	A	A	B	B
			0	0	0	1	1	0	0
			0	5	8	0	5	0	9
			C	C	C	C	C	C	C
1	8607-018	Low Voltage Terminal Strip	X	X	X	X	X	X	X
2	8615-009	Circuit Breaker	X	X					
2	8615-010	Circuit Breaker			X				
2	8615-016	Circuit Breaker				X	X		
2	8615-018	Circuit Breaker						X	X
2	8615-013	Circuit Breaker					X		
3	8401-007	Compressor Contactor	X	X	X	X	X		
3	8401-002	Compressor Contactor						X	X
4	8611-006	Ground Terminal	X	X	X	X	2	X	X
5	8401-006	Heat Contactor	X	X	X	X	2	X	X
6	8407-034	Transformer	X	X	X	X	X	X	X
7	8552-002	Condenser Motor Capacitor	X	X	X	X	X	X	X
8	8201-009	Blower Relay	X	X	X	X	X	X	X
	4008-112	Wiring Diagram	X						
	4008-122	Wiring Diagram		X					
	4008-132	Wiring Diagram			X	X			
	4008-141	Wiring Diagram					X		
	4008-211	Wiring Diagram						X	
	4008-221	Wiring Diagram							X
	132-027	Control Panel Cover	X	X	X	X		X	X
	132-029	Control Panel Cover					X		

WZ30/PARTSLIST/TEXTLIB

CONTROL PANEL
 36WA6
 WITHOUT CIRCUIT BREAKER

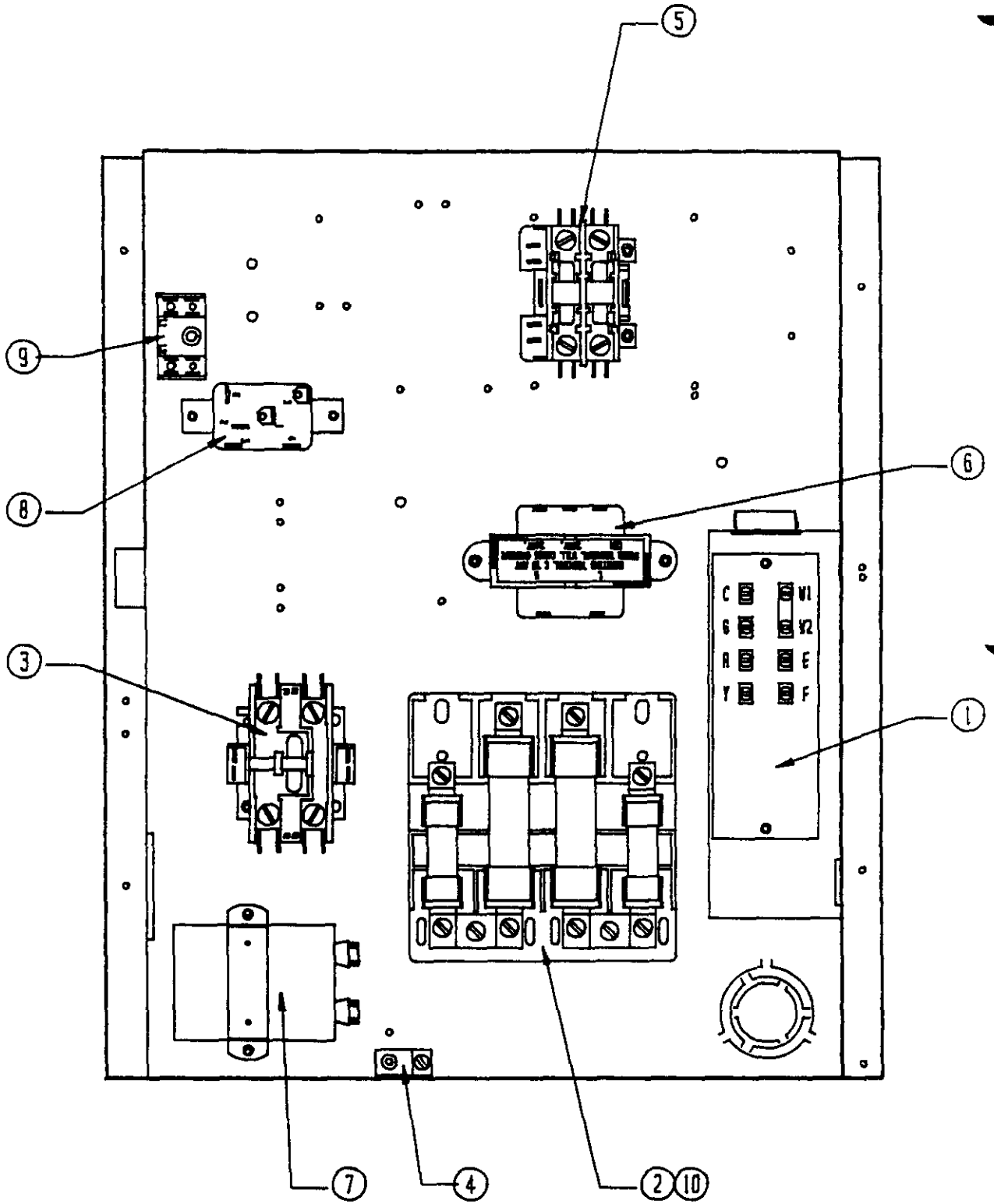

30-36 WA

CONTROL PANEL
36WA6
WITHOUT CIRCUIT BREAKERS

Date: 05/08/89

Dwg. No.	Part No.	Description	3	3	3	3	3	3	3	3	3	3	3	3	3
			6	6	6	6	6	6	6	6	6	6	6	6	6
			W	W	W	W	W	W	W	W	W	W	W	W	W
			A	A	A	A	A	A	A	A	A	A	A	A	A
			6	6	6	6	6	6	6	6	6	6	6	6	6
			A	A	A	A	A	B	B	B	B	C	C	C	
			0	0	0	1	1	0	0	1	1	0	0	1	
			0	5	8	0	5	0	6	9	2	5	0	9	
			N	N	N	N	N	N	N	N	N	N	N	N	
1	8607-018	Low Voltage Terminal Strip	X	X	X	X	X	X	X	X	X	X	X	X	
2	8607-013	Terminal Block		X	X	X									
2	8614-017	Fuse Block					X								
2	8607-014	Terminal Block						X	X	X	X		X	X	
3	8401-007	Compressor Contactor	X	X	X	X	X								
3	8401-002	Compressor Contactor						X	X	X	X	X	X	X	
4	8611-006	Ground Terminal	X	X	X	X	X	X	X	X	X	X	X	X	
5	8401-006	Heat Contactor		X	X	X	2		X	X	2	2			
5	8401-002	Heat Contactor											X	2	
6	8407-034	Transformer	X	X	X	X	X	X	X	X	X				
6	8407-027	Transformer										X	X	X	
7	8552-002	Condenser Motor Capacitor	X	X	X	X	X	X	X	X	X	X	X	X	
8	8201-009	Blower Relay	X	X	X	X	X	X	X	X	X				
8	8201-032	Blower Relay										X	X	X	
9	8607-017	Terminal Block										X	X	X	
10	8607-015	Phenolic Insulator											X	X	
	4009-110	Wiring Diagram	X												
	4009-120	Wiring Diagram		X											
	4009-130	Wiring Diagram			X	X									
	4009-140	Wiring Diagram					X								
	4009-210	Wiring Diagram						X							
	4009-220	Wiring Diagram							X	X					
	4009-230	Wiring Diagram									X	X			
	4009-310	Wiring Diagram										X			
	4009-320	Wiring Diagram											X		
	4009-332	Wiring Diagram												X	
	132-003	Control Panel Cover	X	X	X	X		X	X	X	X	X	X	X	
	133-036	Control Panel Cover					X								

WZ31/PARTSLIST/TEXTLIB

CONTROL PANEL
36WA6
WITH CIRCUIT BREAKER

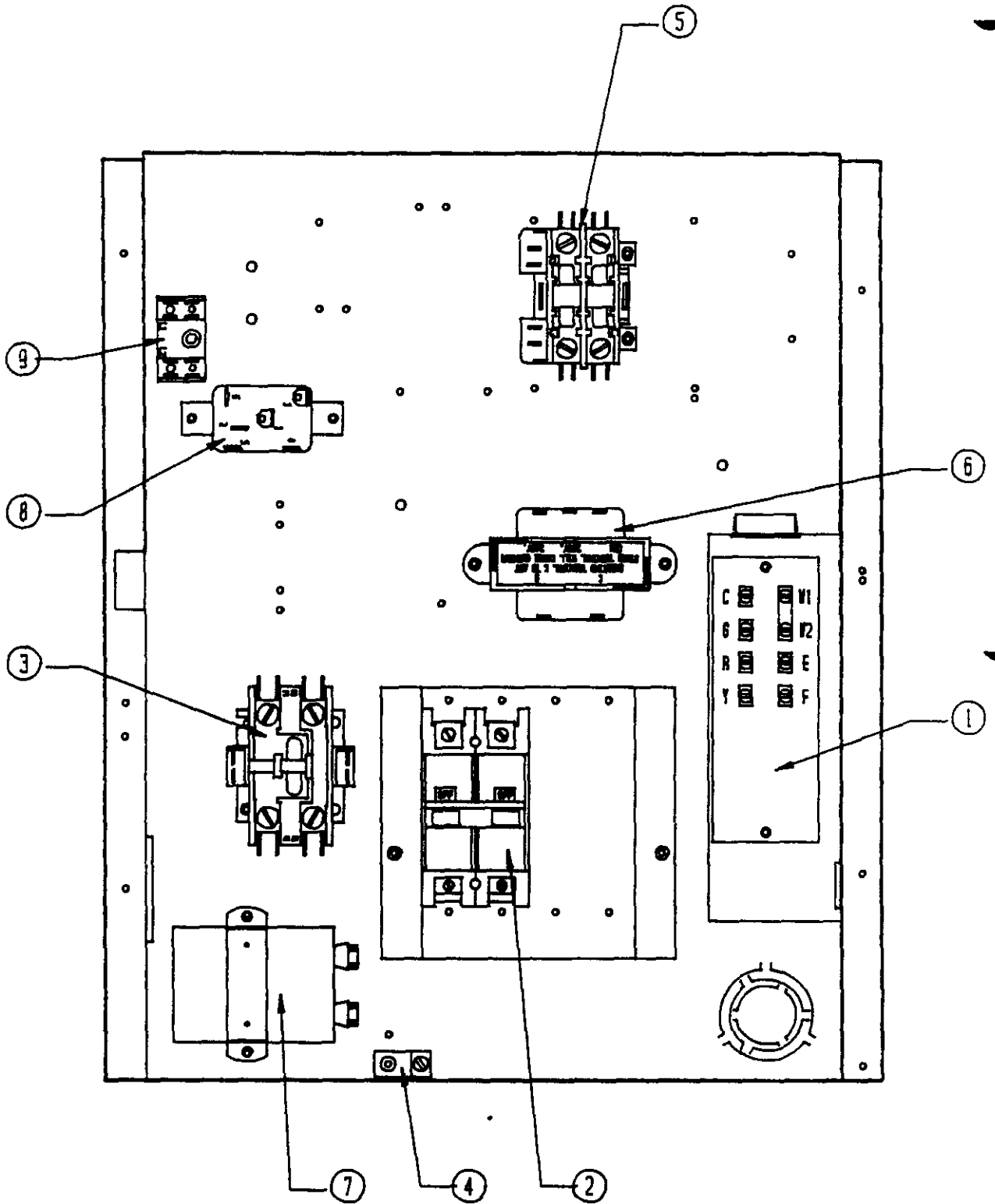

30-36 WA

CONTROL PANEL
36WA6
WITH CIRCUIT BREAKER

Date: 05/08/89

Dwg. No.	Part No.	Description	3	3	3	3	3	3	3	3	3	3	3	3
			6	6	6	6	6	6	6	6	6	6	6	6
			W	W	W	W	W	W	W	W	W	W	W	W
			A	A	A	A	A	A	A	A	A	A	A	A
			6	6	6	6	6	6	6	6	6	6	6	6
			A	A	A	A	A	B	B	B	B	C	C	C
			0	0	0	1	1	0	0	0	1	1	0	1
			0	5	8	0	5	0	6	9	2	5	0	9
			C	C	C	C	C	C	C	C	C	C	C	C
1	8607-018	Low Voltage Terminal Strip	X	X	X	X	X	X	X	X	X	X	X	X
2	8615-010	Circuit Breaker	X	X	X									
2	8615-023	Circuit Breaker										X	X	
2	8615-016	Circuit Breaker				X	X							
2	8615-013	Circuit Breaker					X							
2	8615-019	Circuit Breaker						X	X	X				
2	8615-020	Circuit Breaker									X			
2	8615-007	Circuit Breaker										X		
2	8615-025	Circuit Breaker												X
3	8401-007	Compressor Contactor	X	X	X	X	X							
3	8401-002	Compressor Contactor						X	X	X	X	X	X	X
4	8611-006	Ground Terminal	X	X	X	X	2	X	X	X	X	X	X	X
5	8401-006	Heat Contactor		X	X	X	2		X	X	2	2		
5	8401-002	Heat Contactor											X	2
6	8407-034	Transformer	X	X	X	X	X	X	X	X	X			
6	8407-027	Transformer										X	X	X
7	8552-002	Condenser Motor Capacitor	X	X	X	X	X	X	X	X	X	X	X	X
8	8201-009	Blower Relay	X	X	X	X	X	X	X	X	X			
8	8201-032	Blower Relay										X	X	X
9	8607-017	Terminal Block										X	X	X
	4009-111	Wiring Diagram	X											
	4009-121	Wiring Diagram		X										
	4009-131	Wiring Diagram			X	X								
	4009-141	Wiring Diagram					X							
	4009-211	Wiring Diagram						X						
	4009-221	Wiring Diagram							X	X				
	4009-231	Wiring Diagram								X	X			
	4009-311	Wiring Diagram										X		
	4009-321	Wiring Diagram											X	
	4009-333	Wiring Diagram												X
	132-027	Control Panel Cover	X	X	X	X								
	132-029	Control Panel Cover					X							
	132-050	Control Panel Cover										X	X	X
	132-028	Control Panel Cover						X	X	X	X			

WZ32/PARTSLIST/TEXTLIB

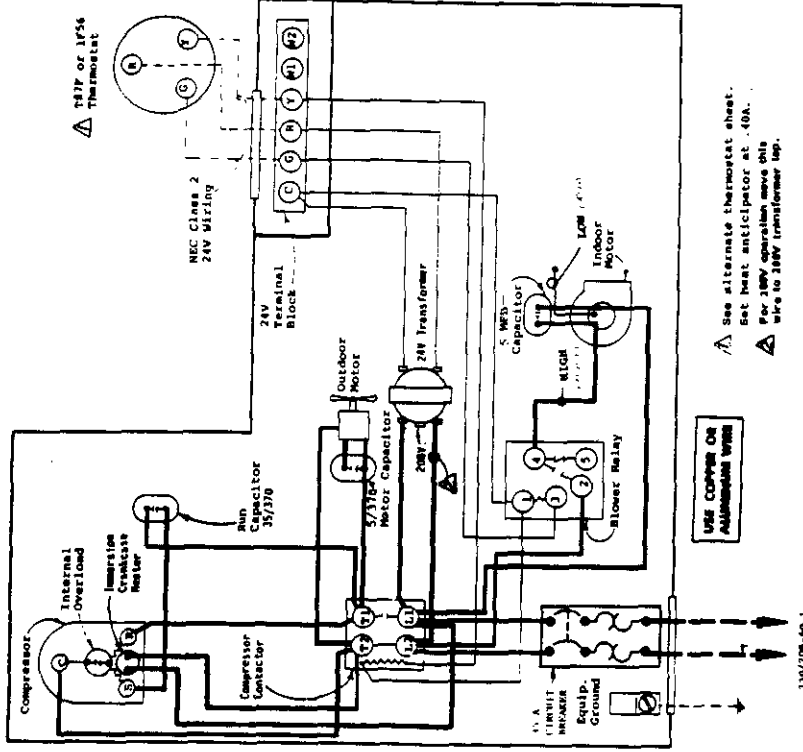

See alternate thermostat sheet.
 Set heat anticipator at .40A.
 For 24V operation use this wire to 24V transformer tap.

USE COPPER OR ALUMINUM WIRE

FACTORY WIRING	FIELD WIRING
Low Voltage	-----
High Voltage	-----

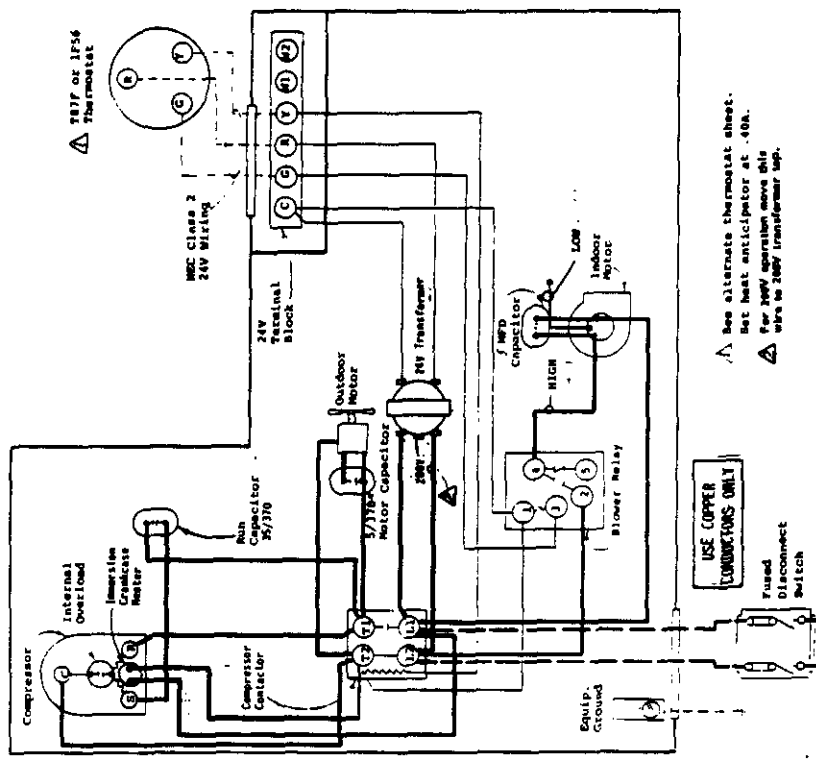

See alternate thermostat sheet.
 Set heat anticipator at .40A.
 For 24V operation use this wire to 24V transformer tap.

USE COPPER WIRE ONLY

FACTORY WIRING	FIELD WIRING
Low Voltage	-----
High Voltage	-----

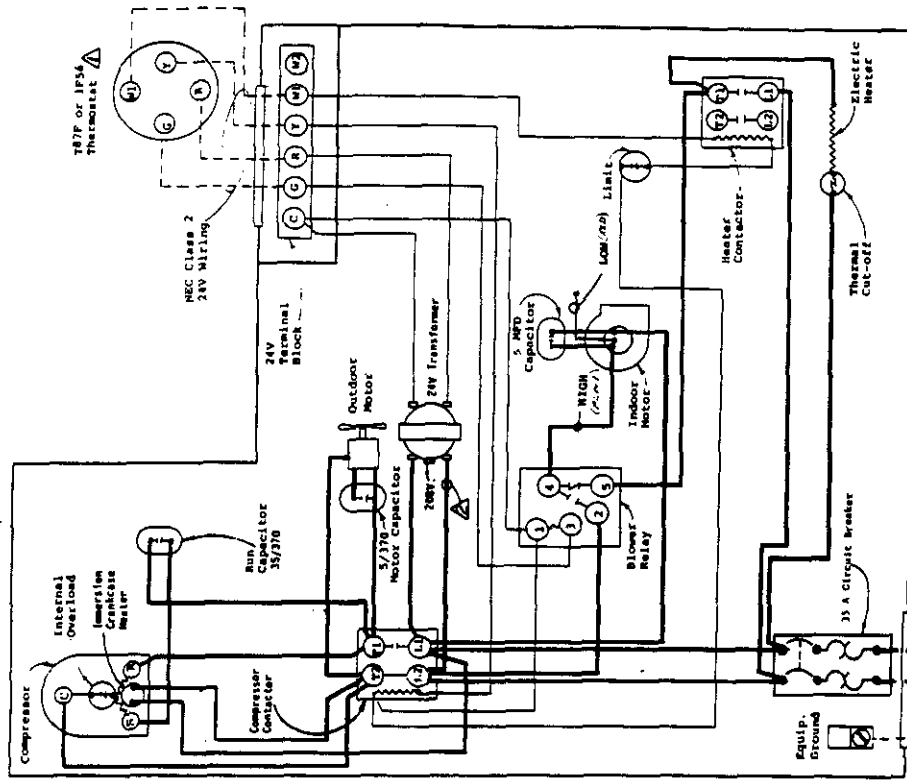

▲ See alternate thermostat sheet. Set heat anticipator at .40A.
 ▲ For 24V operation move this wire to 24V transformer tap.

USE COPPER OR ALUMINUM WIRE

FACTORY WIRING	FIELD WIRING
Low Voltage	-----
High Voltage	-----

400B-122 E

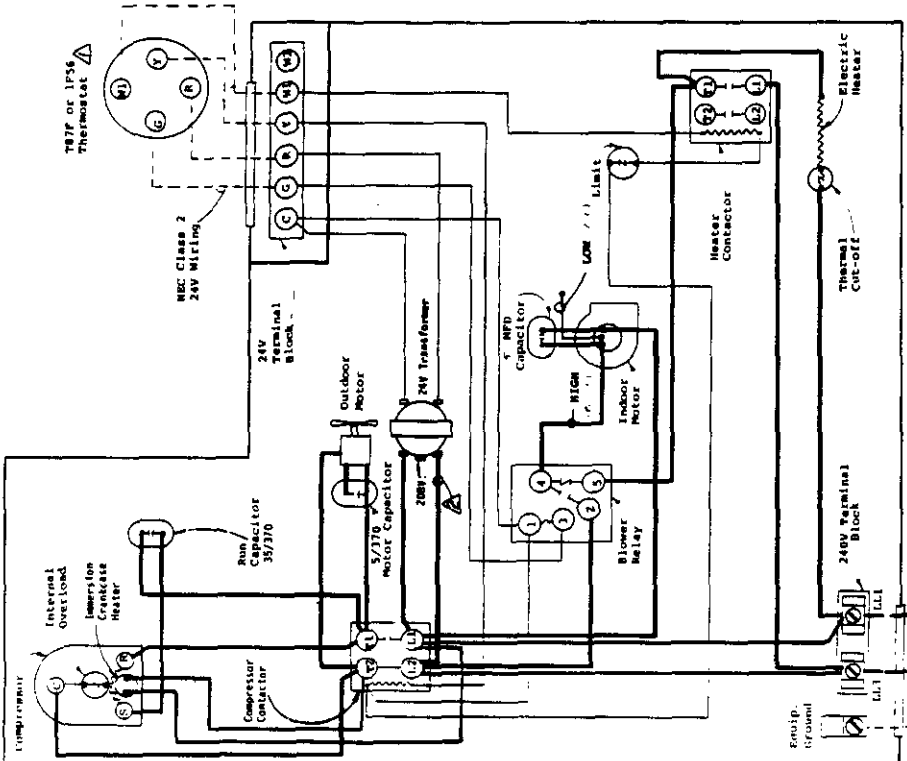

▲ See alternate thermostat sheet. Set heat anticipator at .40A.
 ▲ For 24V operation move this wire to 24V transformer tap.

USE COPPER OR ALUMINUM WIRE

FACTORY WIRING	FIELD WIRING
Low Voltage	-----
High Voltage	-----

400B-120 K

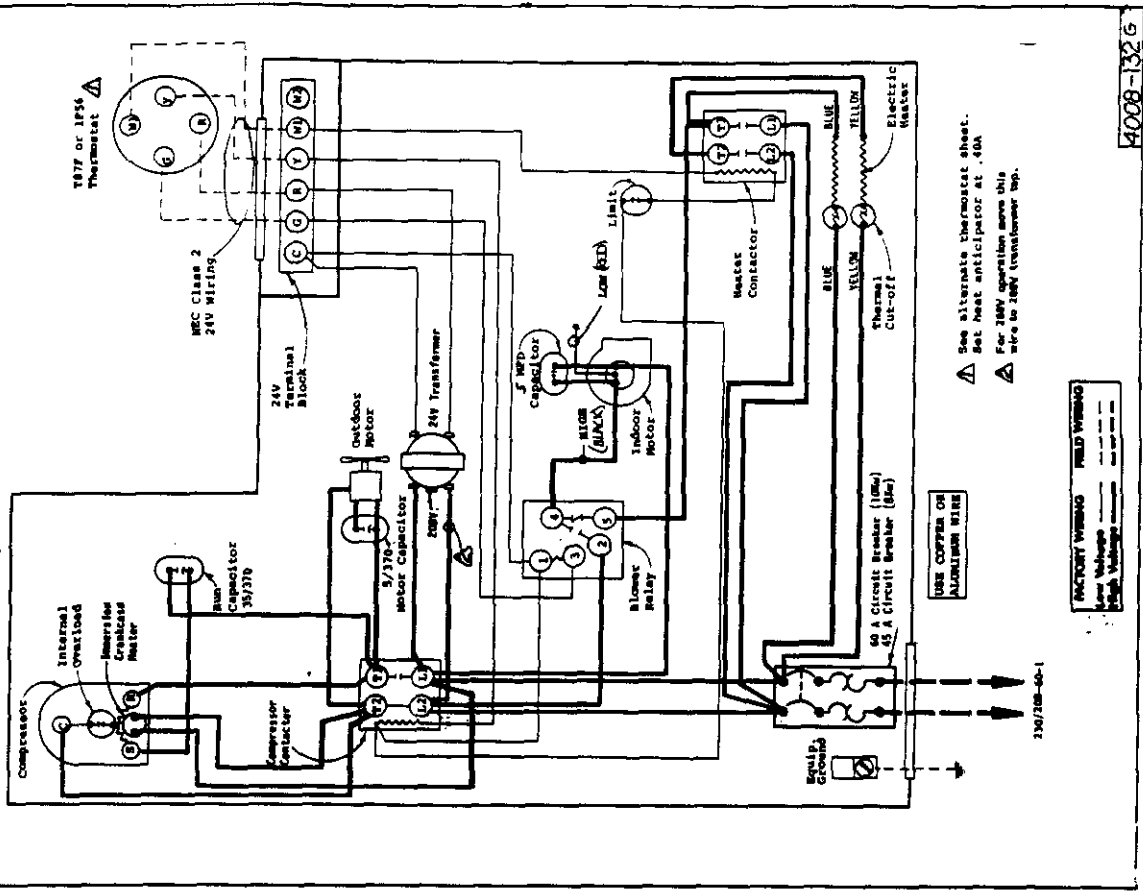

4008-132 G

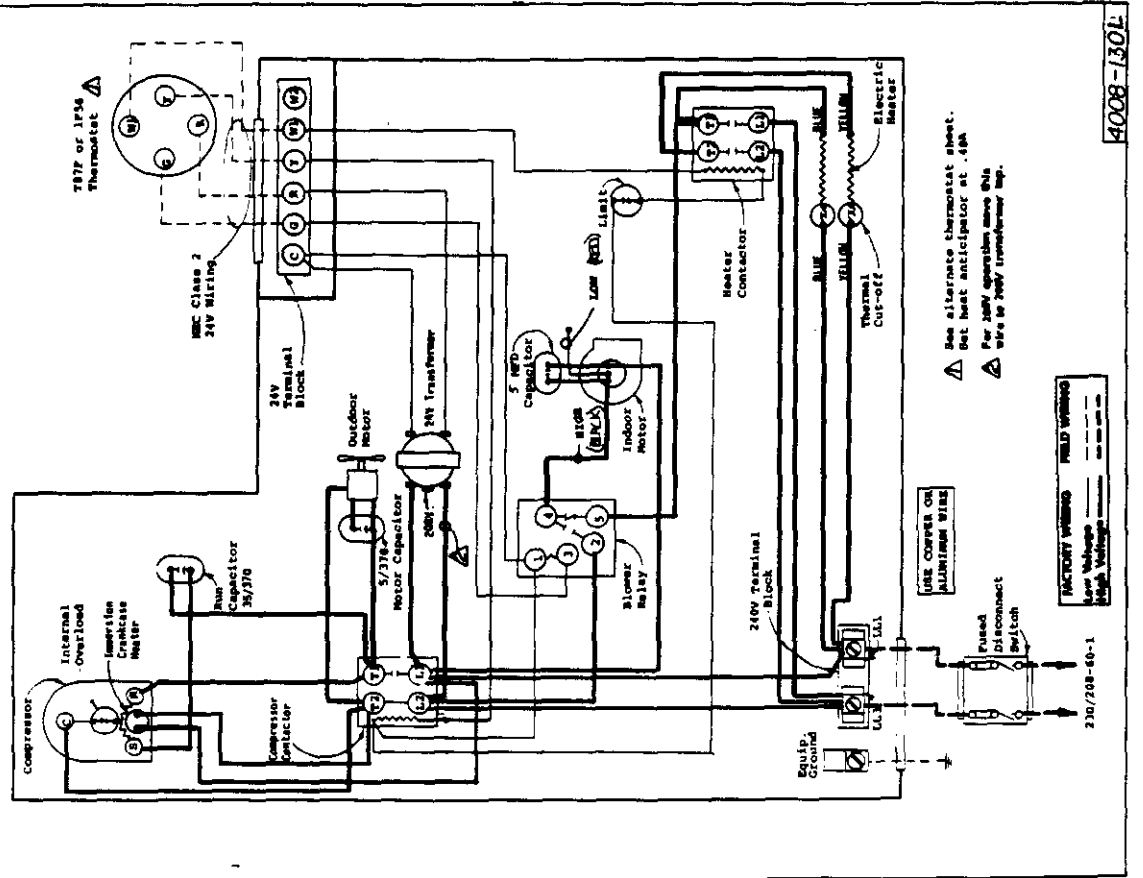

4008-130 L

7874C1000 Thermostat
Q674A1001 Subbase

or
7872C1004 Thermostat
Q672A1005 Subbase

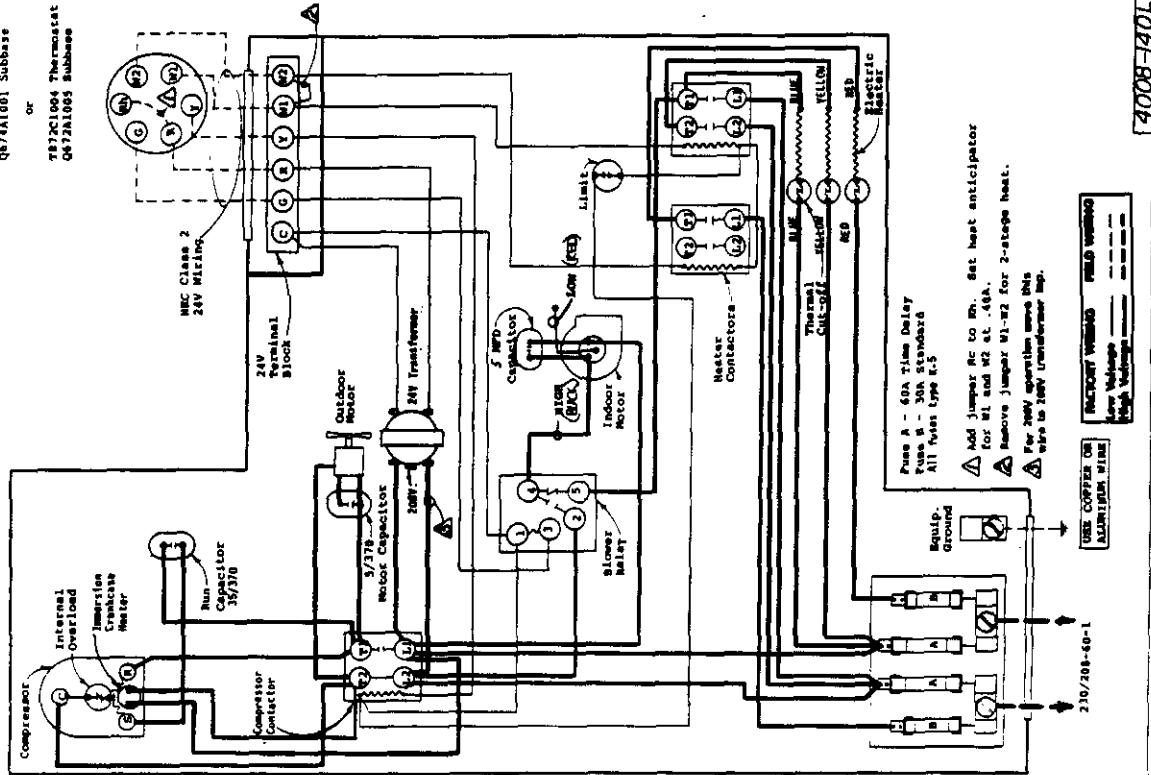

- ▲ Add jumper R1 to R2. Set heat anticipator for R1 and R2 at .40A.
- ▲ Remove jumper W1-W2 for 2-stage heat.
- ▲ For 200V operation move this wire to 200V transformer tap.

USE COPPER OR ALUMINUM WIRE
FACTORY WIRING
Low Voltage
High Voltage

4008-1401

7874C1000 Thermostat
Q674A1001 Subbase

or
7872C1004 Thermostat
Q672A1005 Subbase

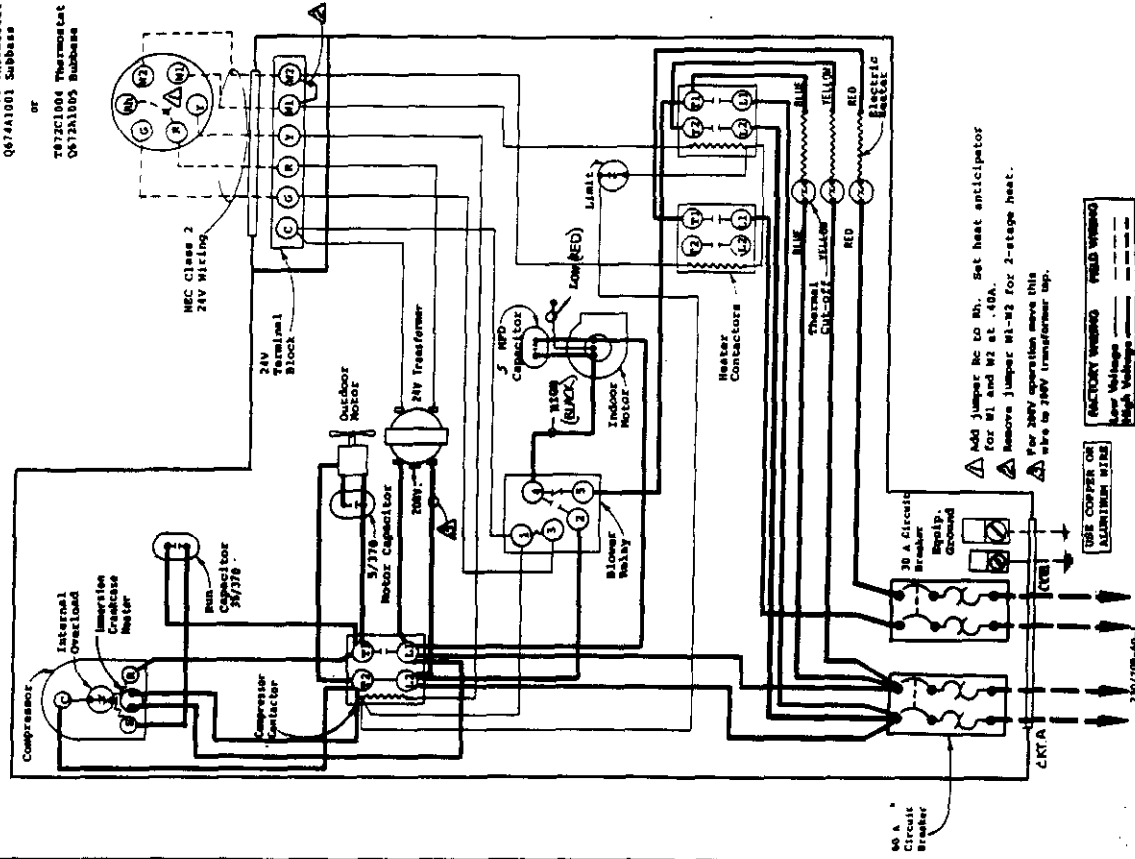

- ▲ Add jumper R1 to R2. Set heat anticipator for R1 and R2 at .40A.
- ▲ Remove jumper W1-W2 for 2-stage heat.
- ▲ For 200V operation move this wire to 200V transformer tap.

USE COPPER OR ALUMINUM WIRE
FACTORY WIRING
Low Voltage
High Voltage

4008-1402

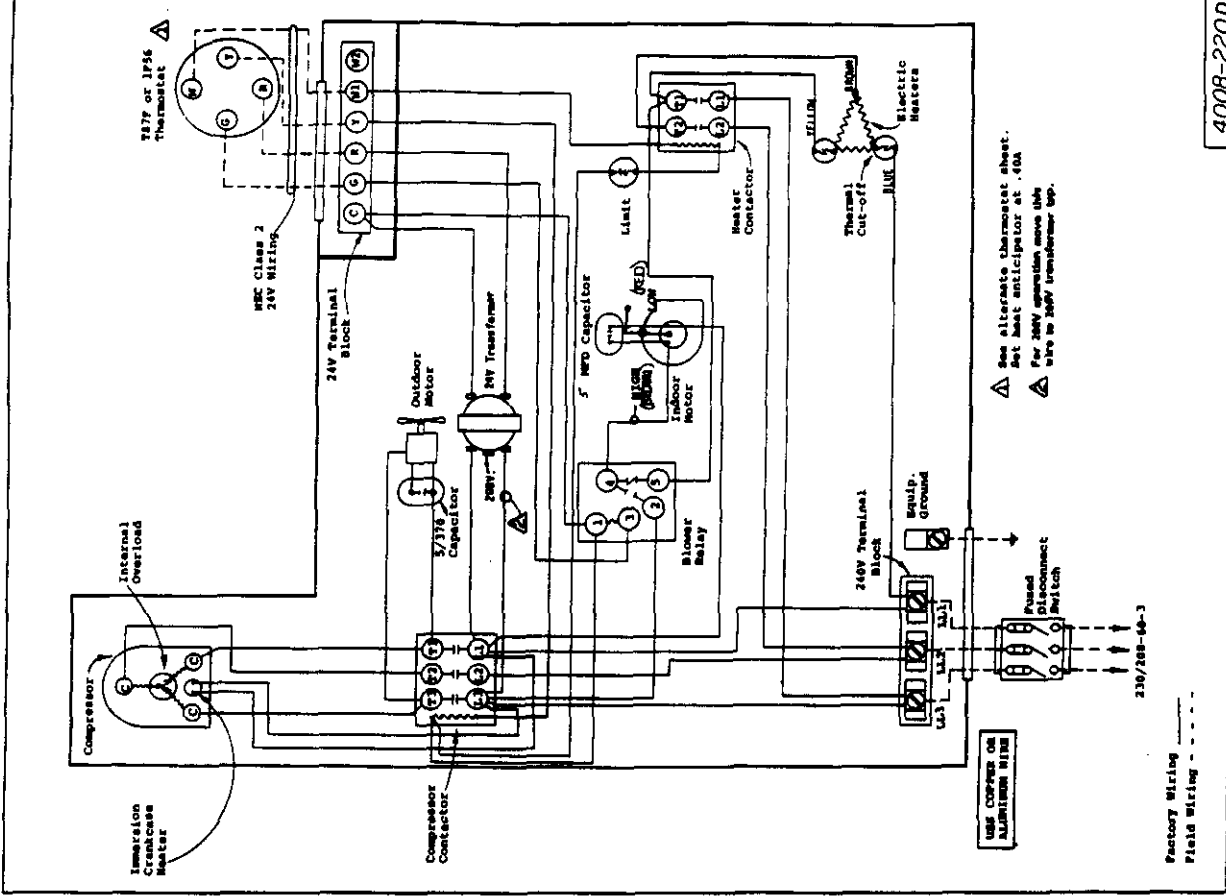

4008-220D

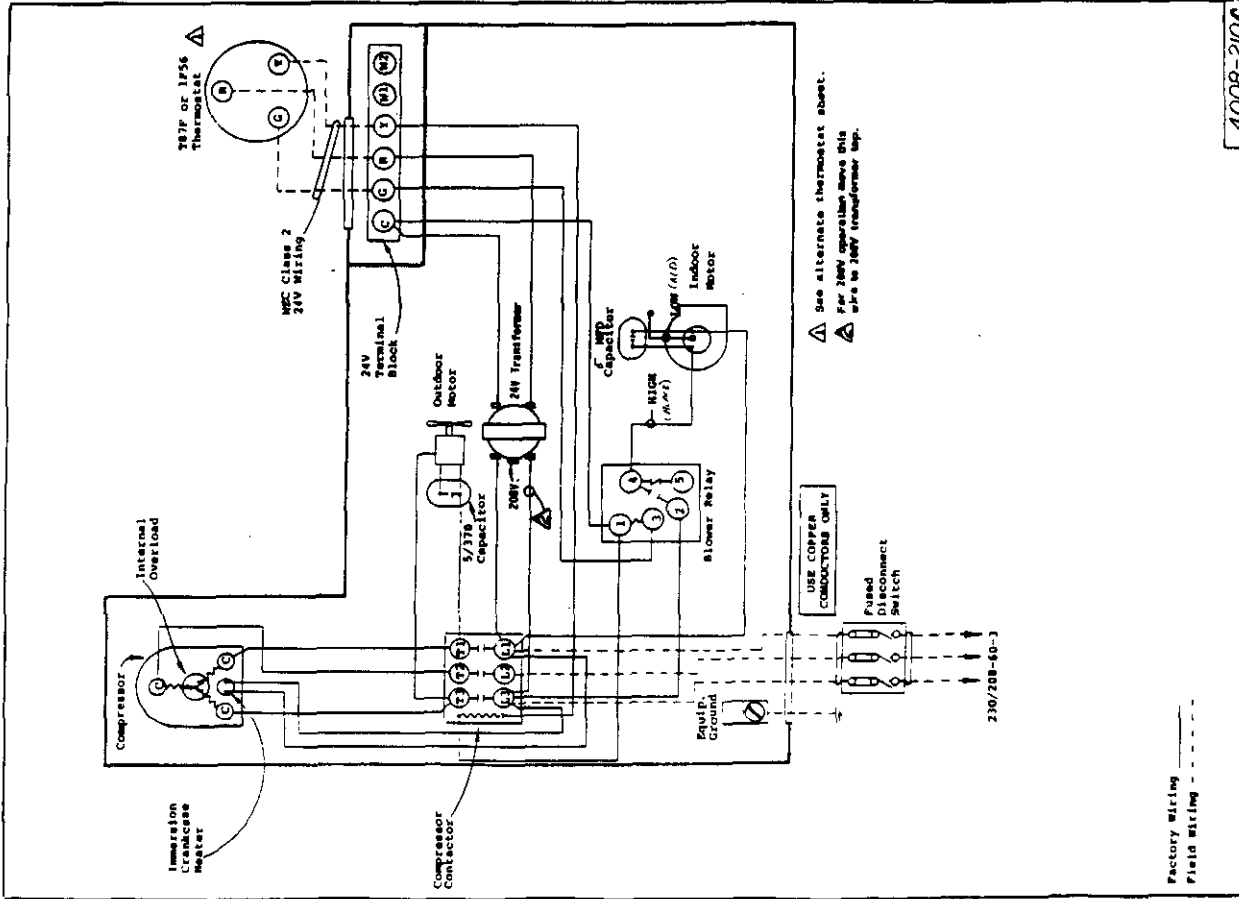

4008-210C

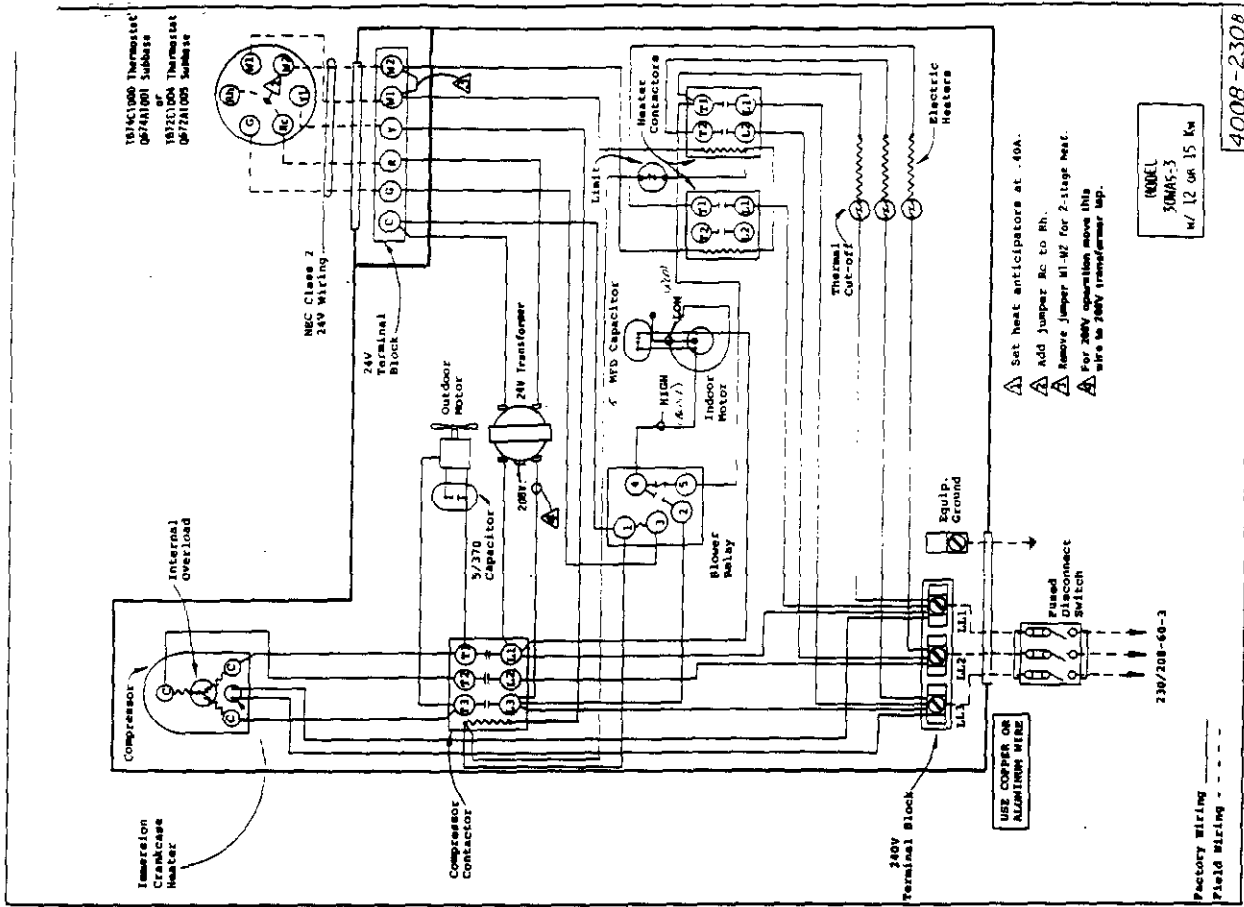
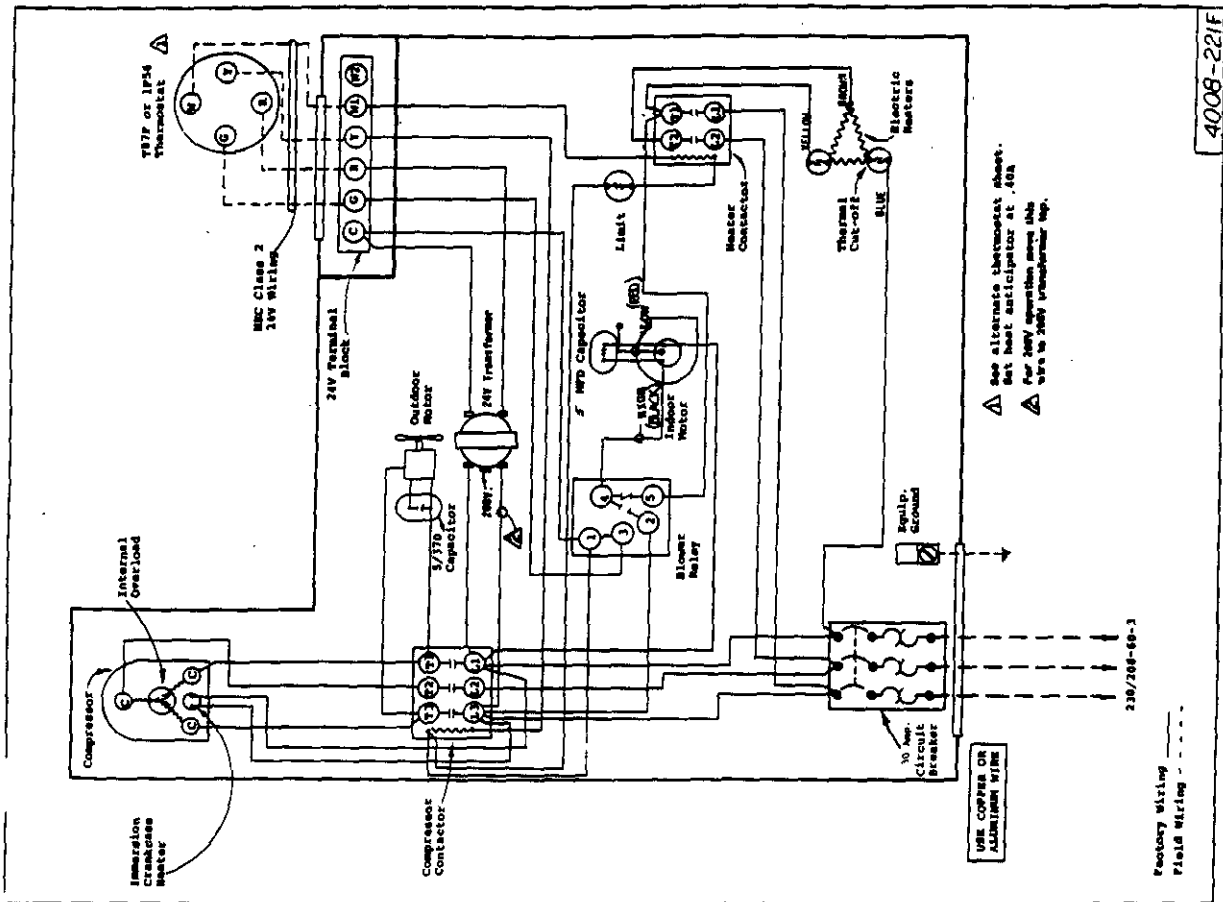

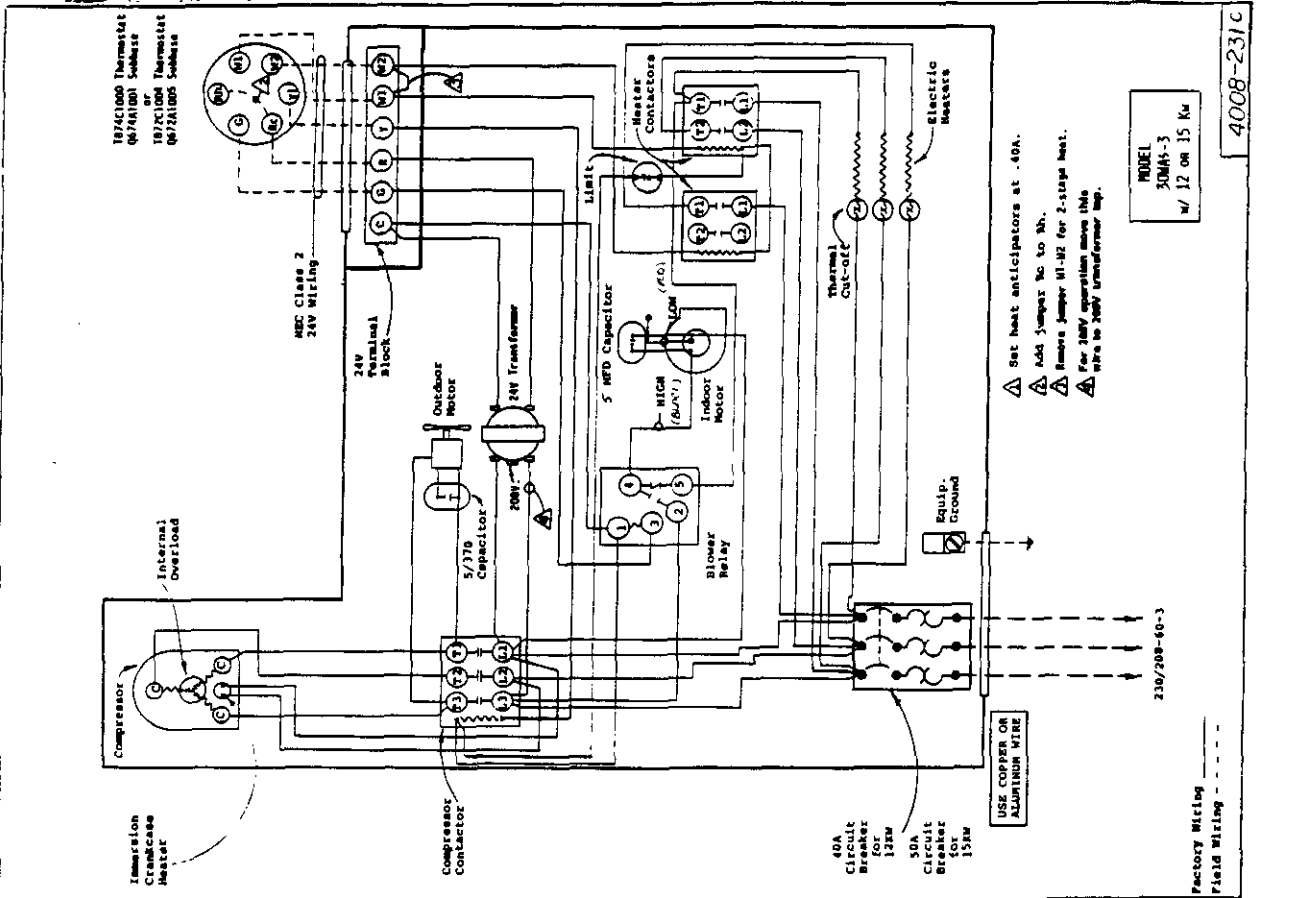
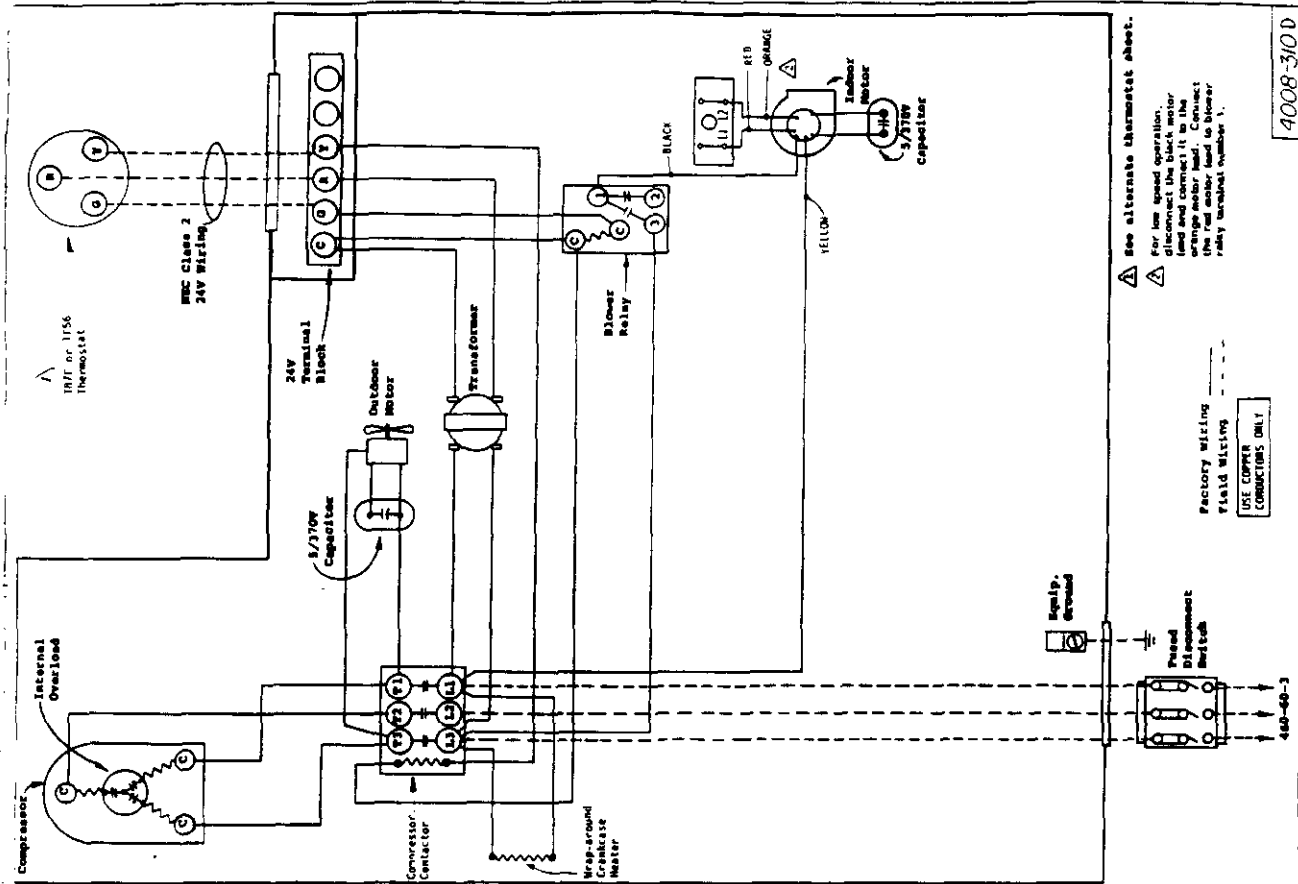

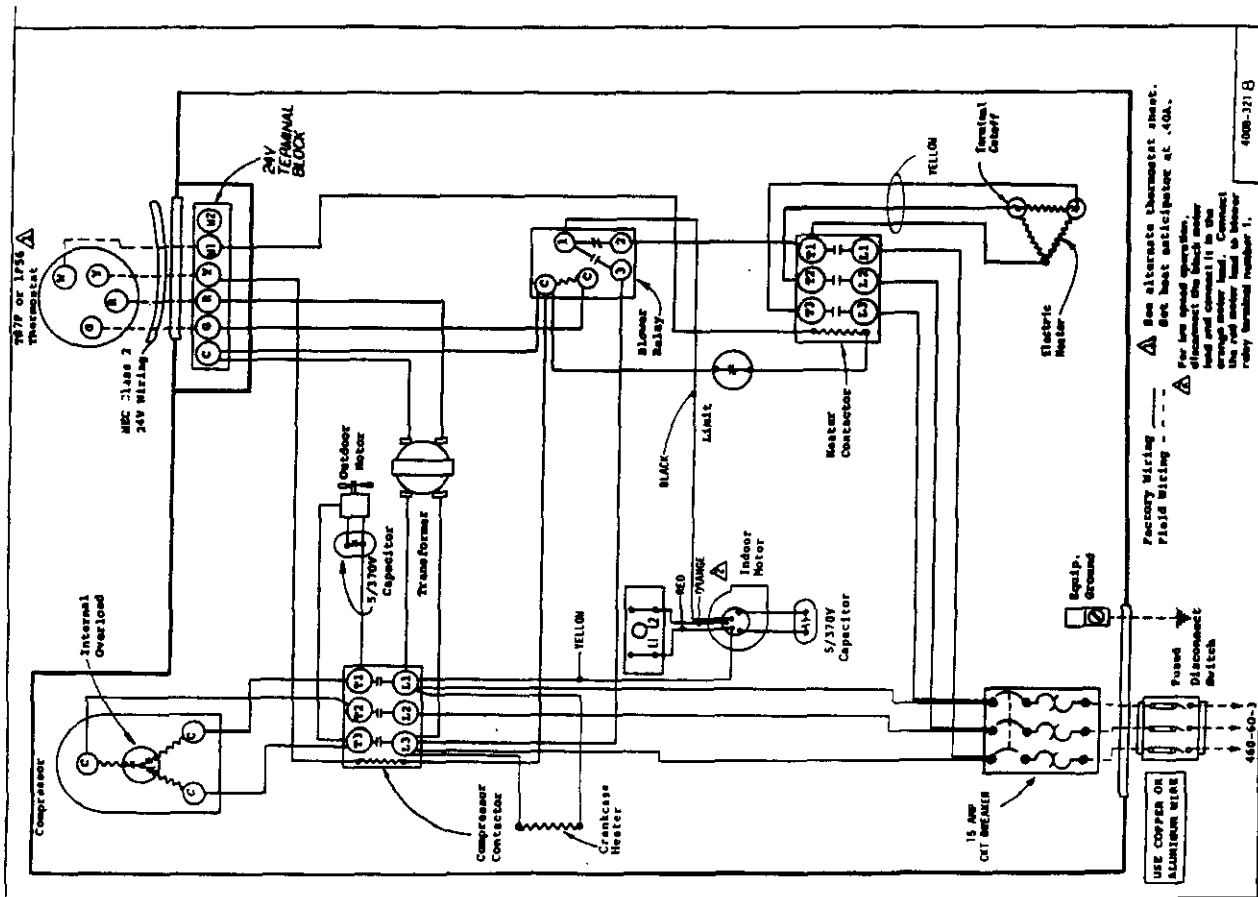
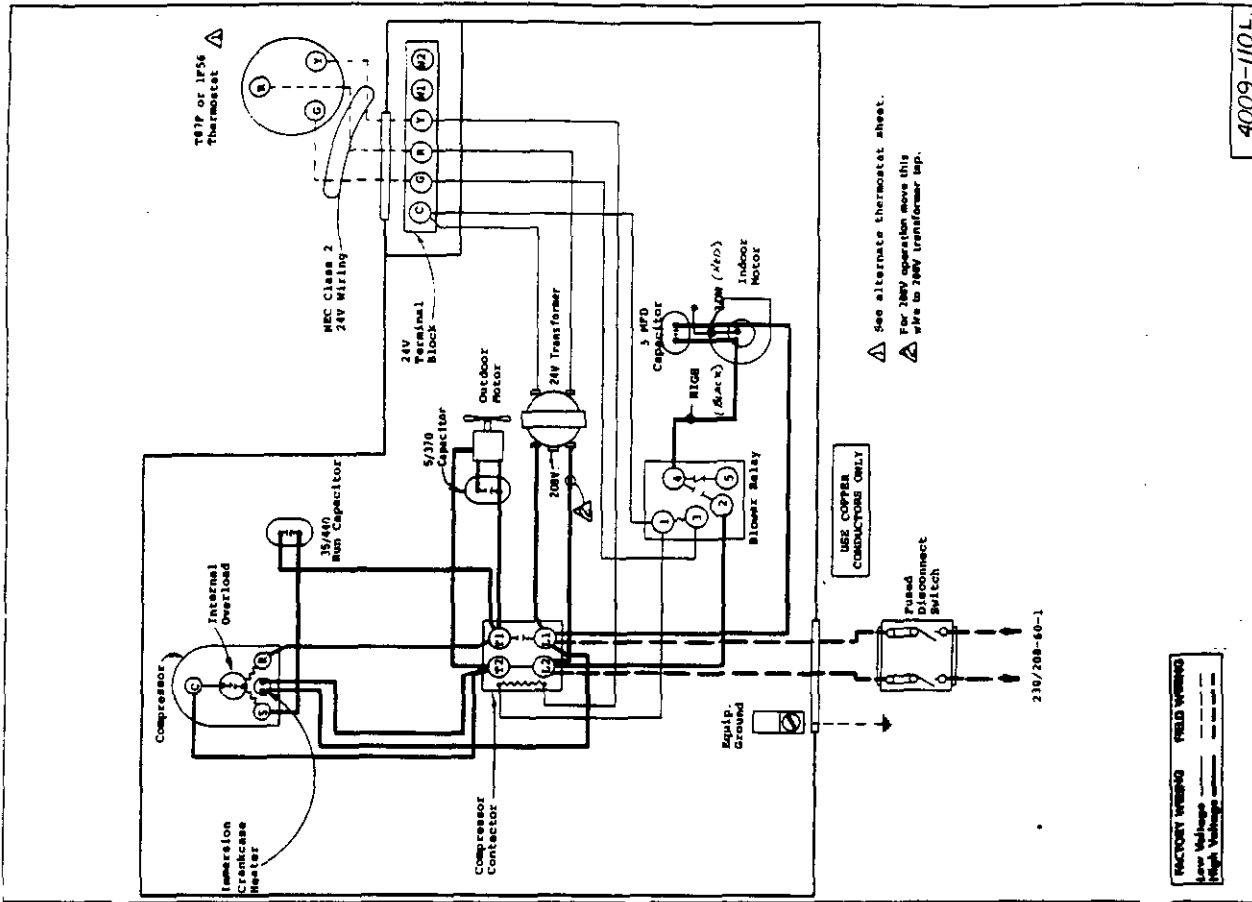

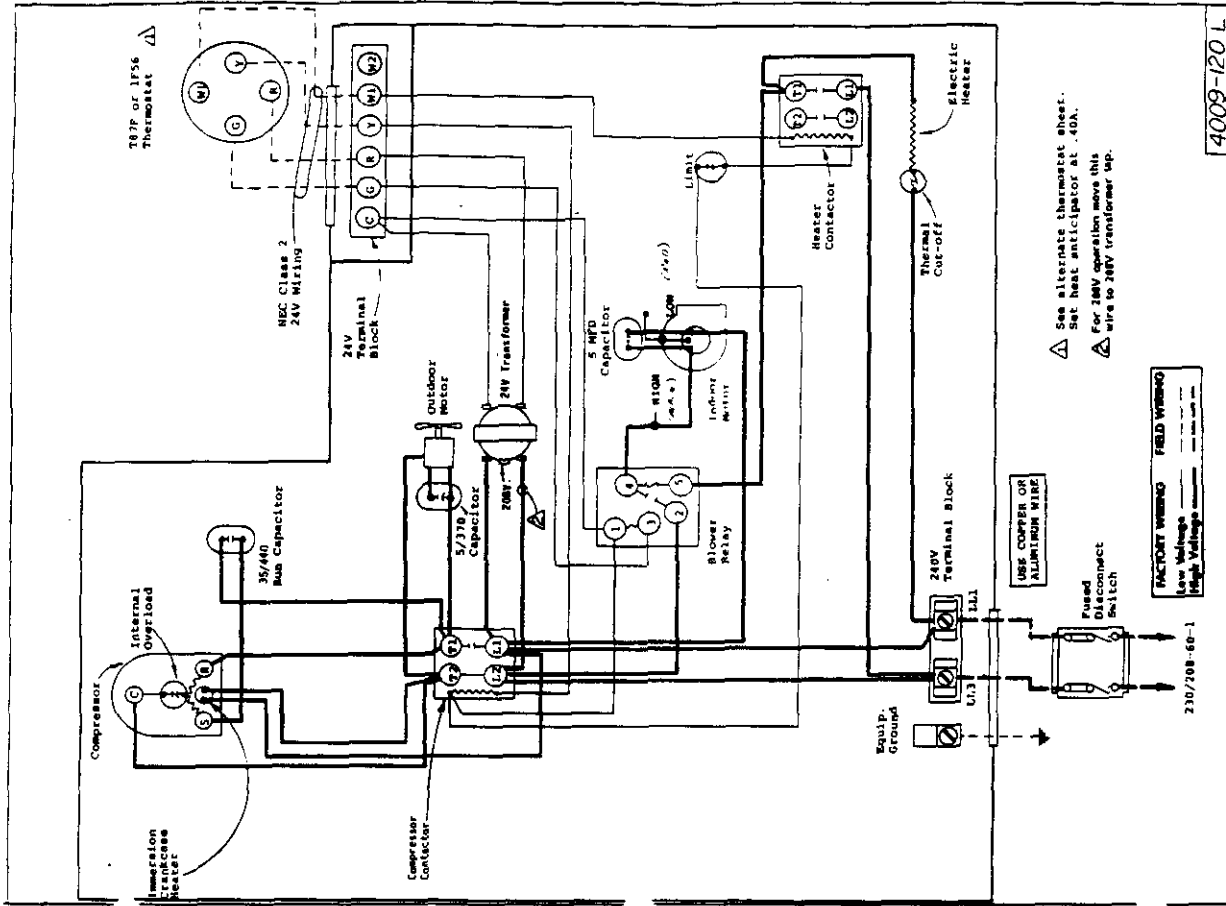
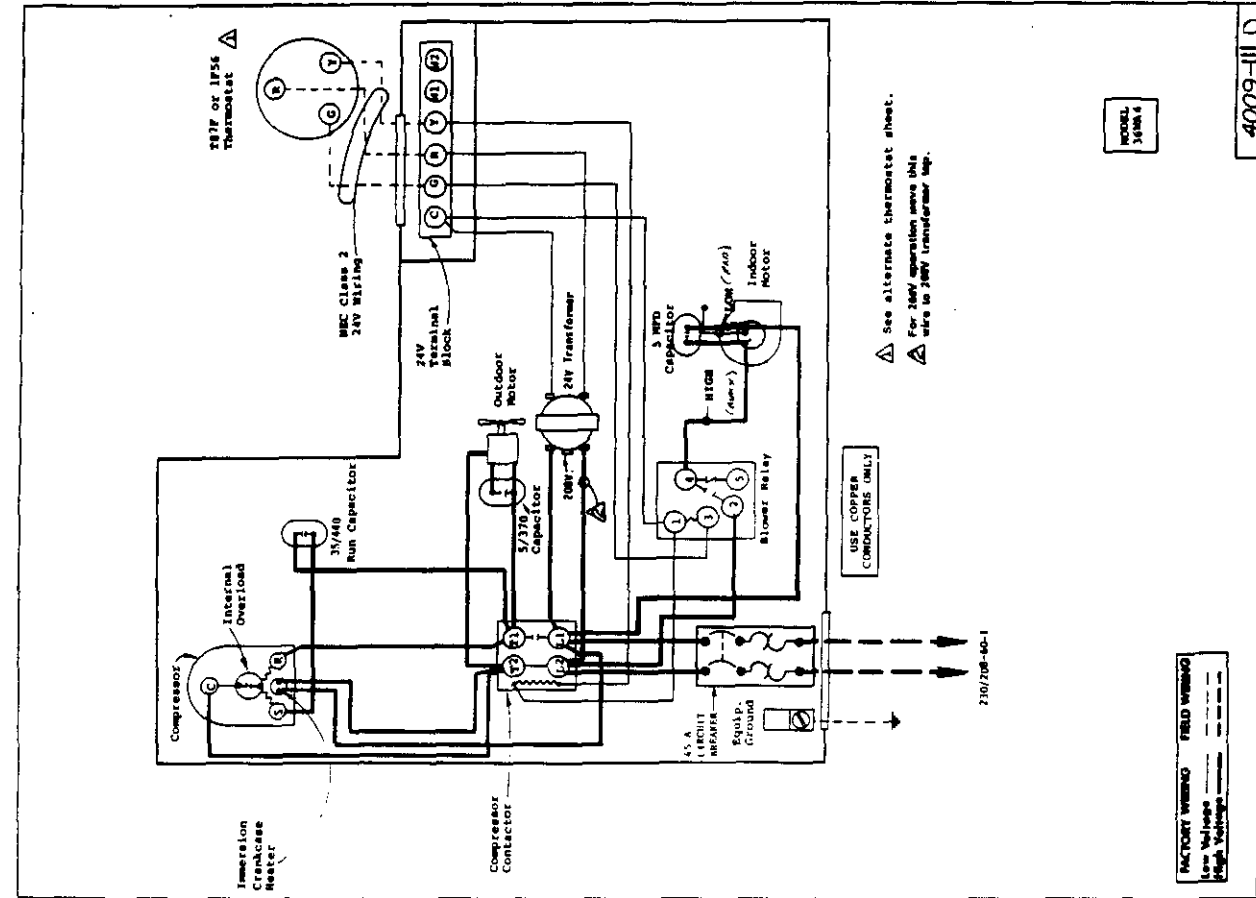

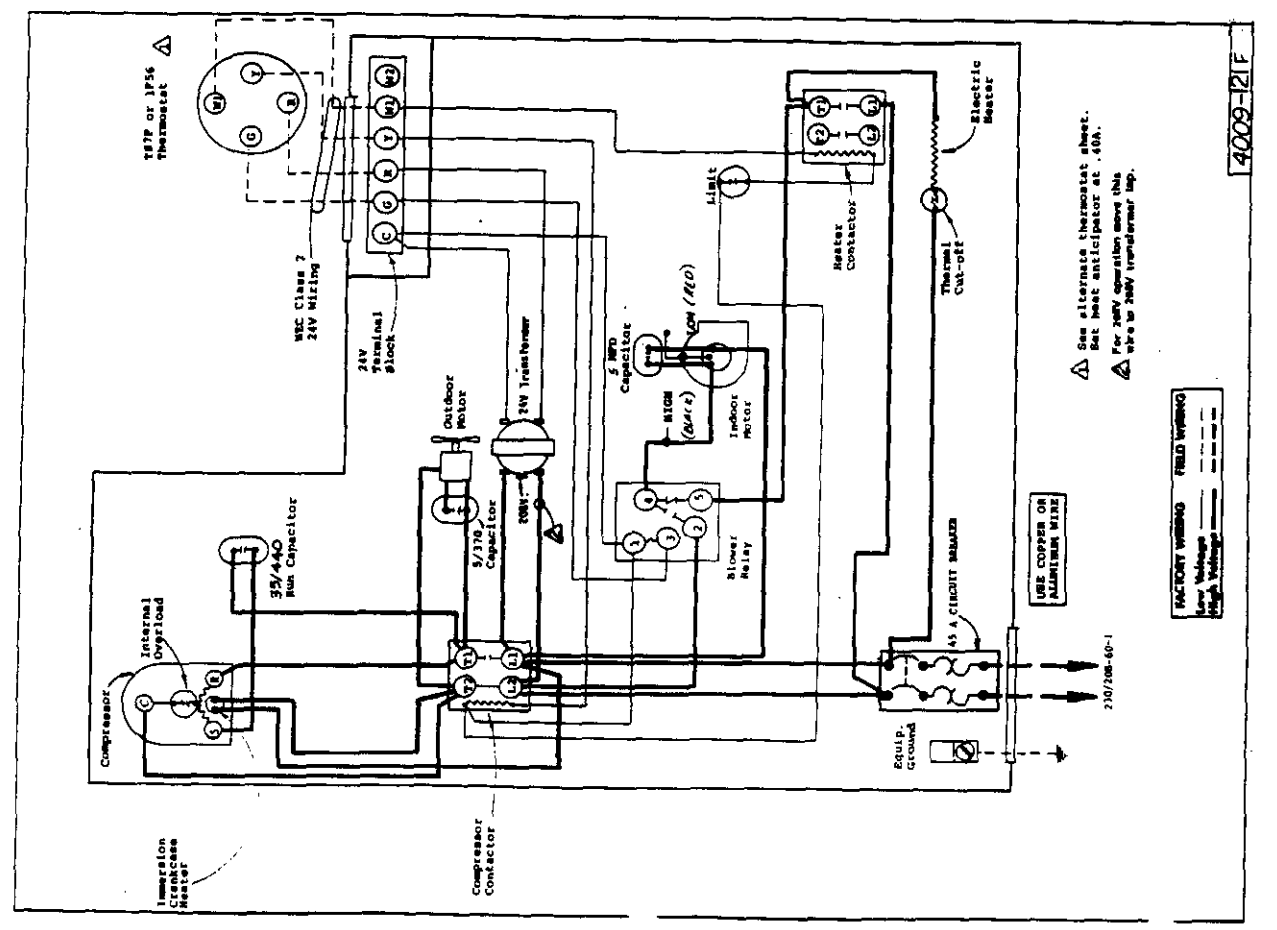
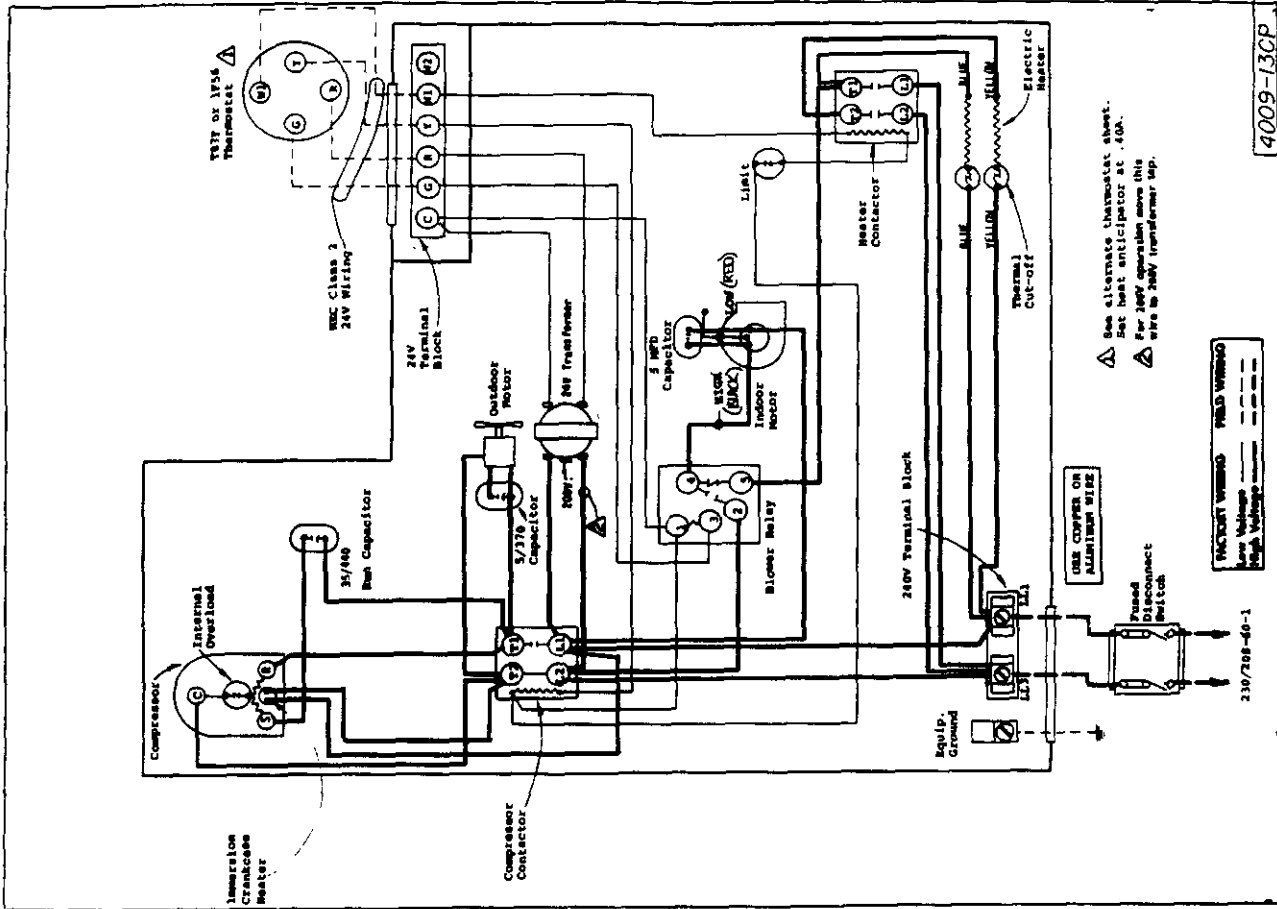

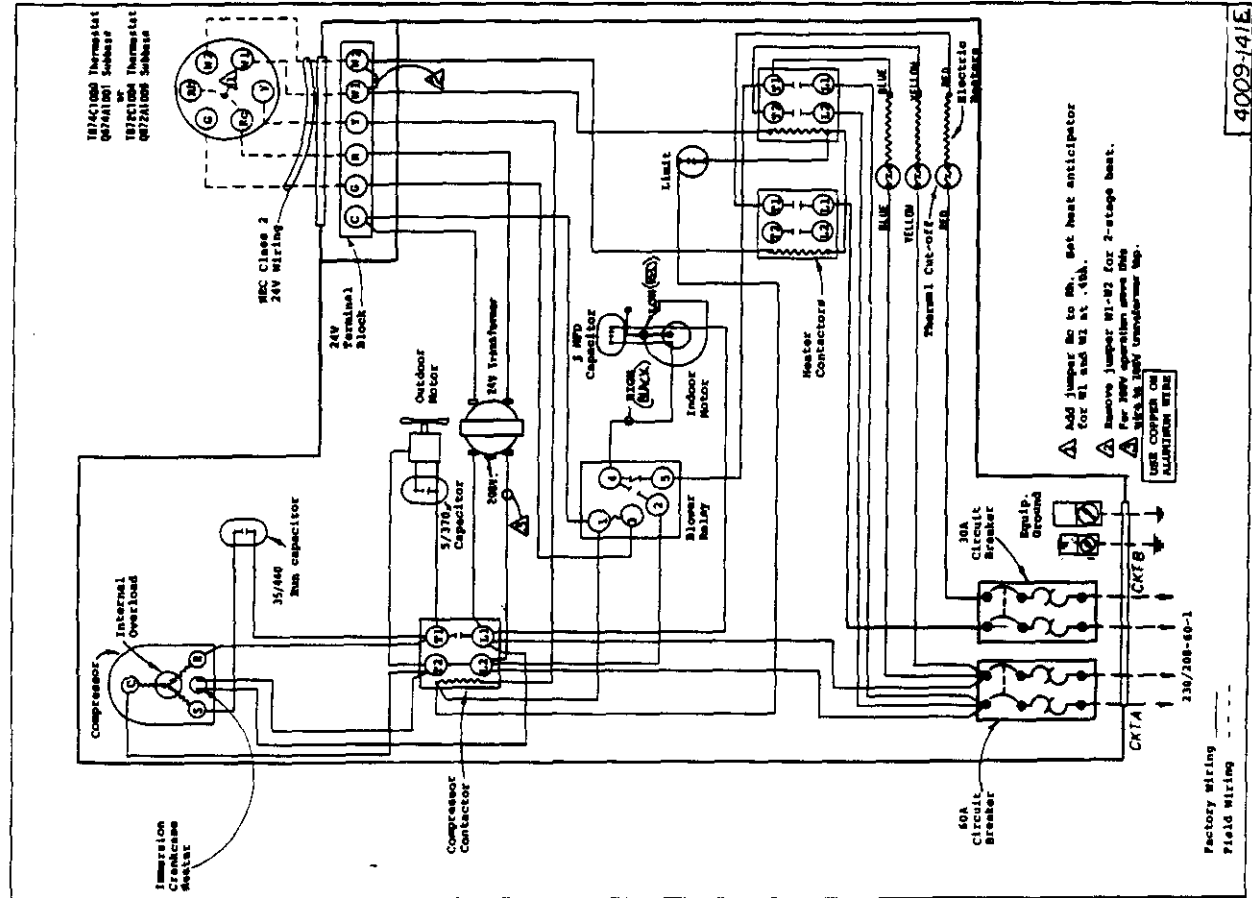

Factory Wiring
Field Wiring

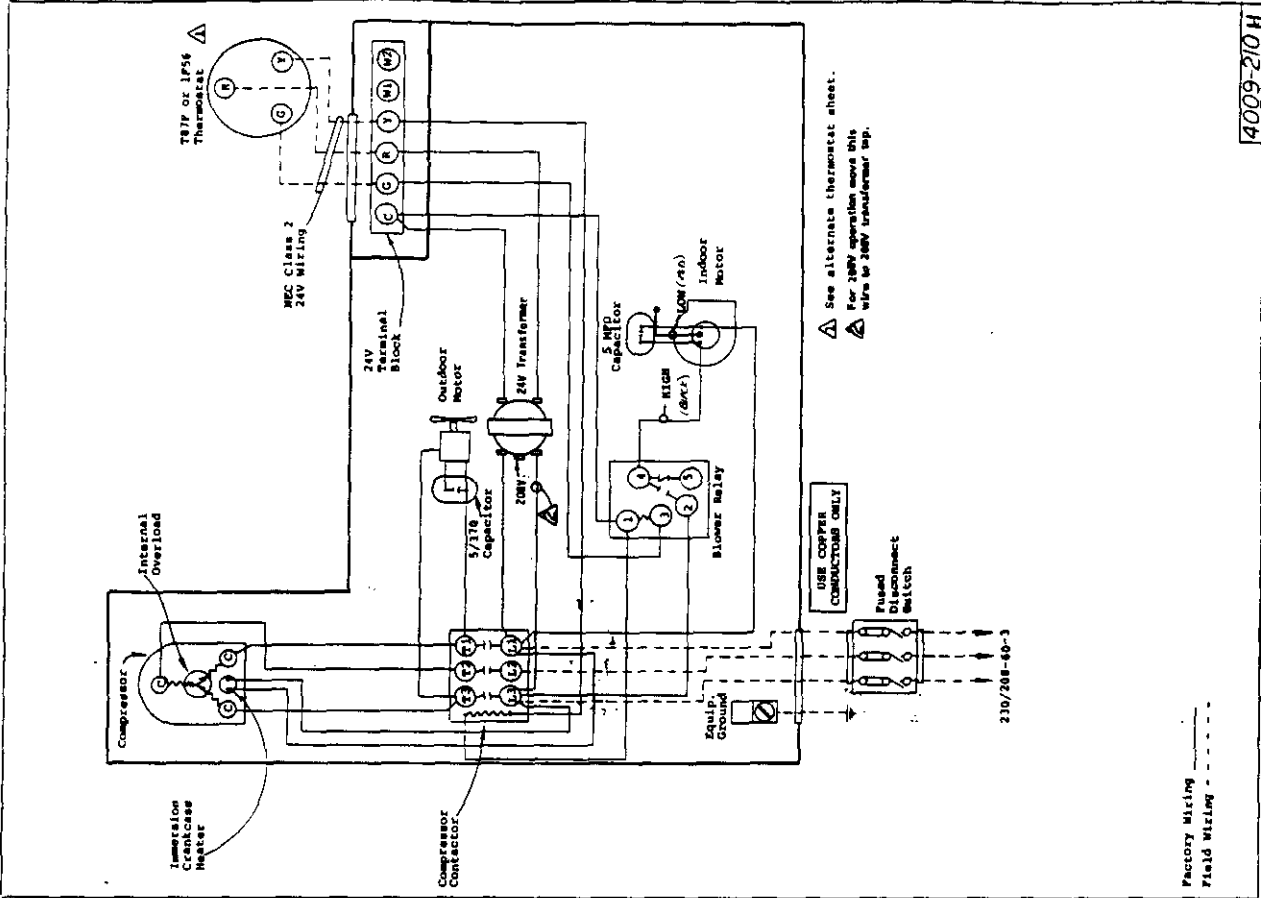

Factory Wiring
Field Wiring

See alternate thermostat sheet.
For 240V operation move this wire to 240V transformer tap.

USE COPPER CONDUCTORS ONLY
Fused Disconnect Switch

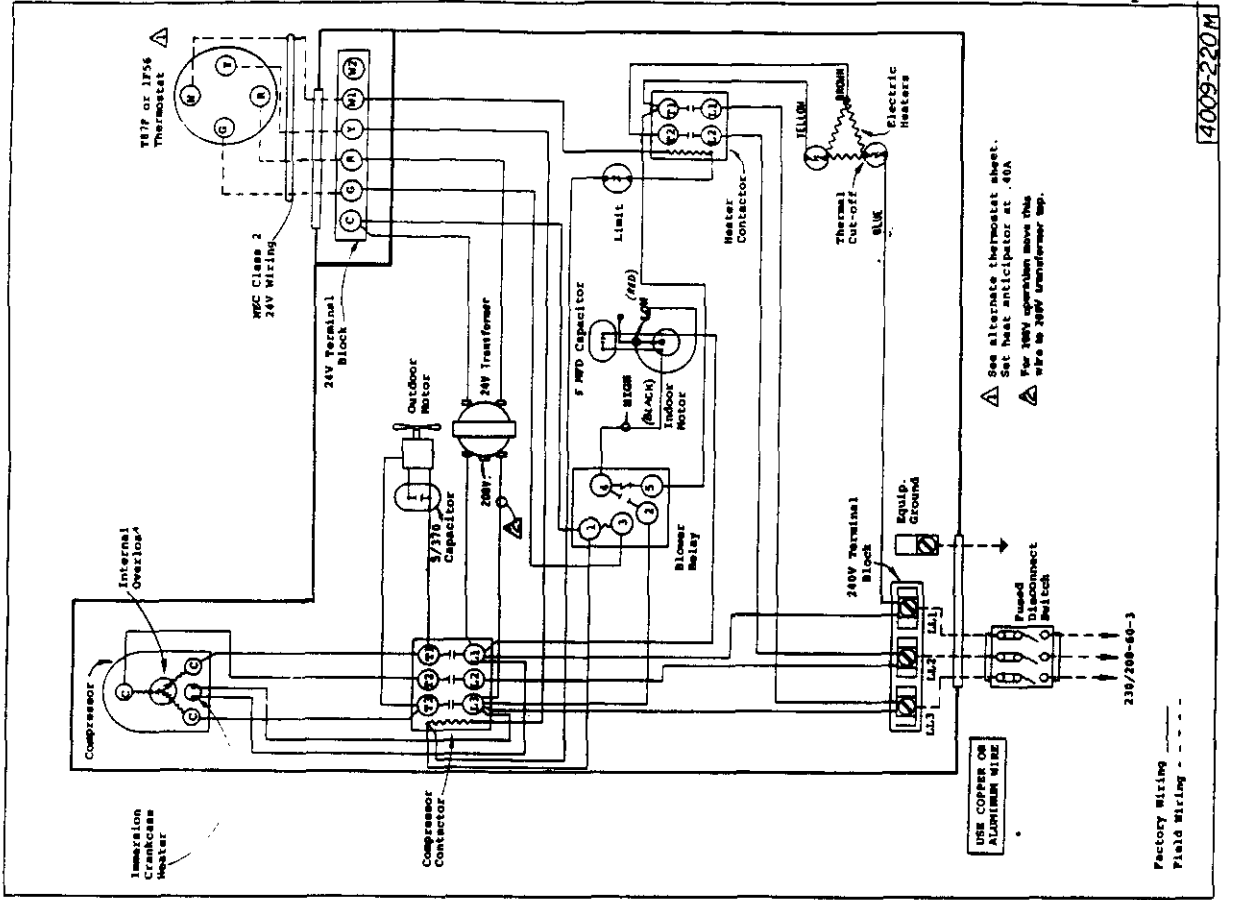
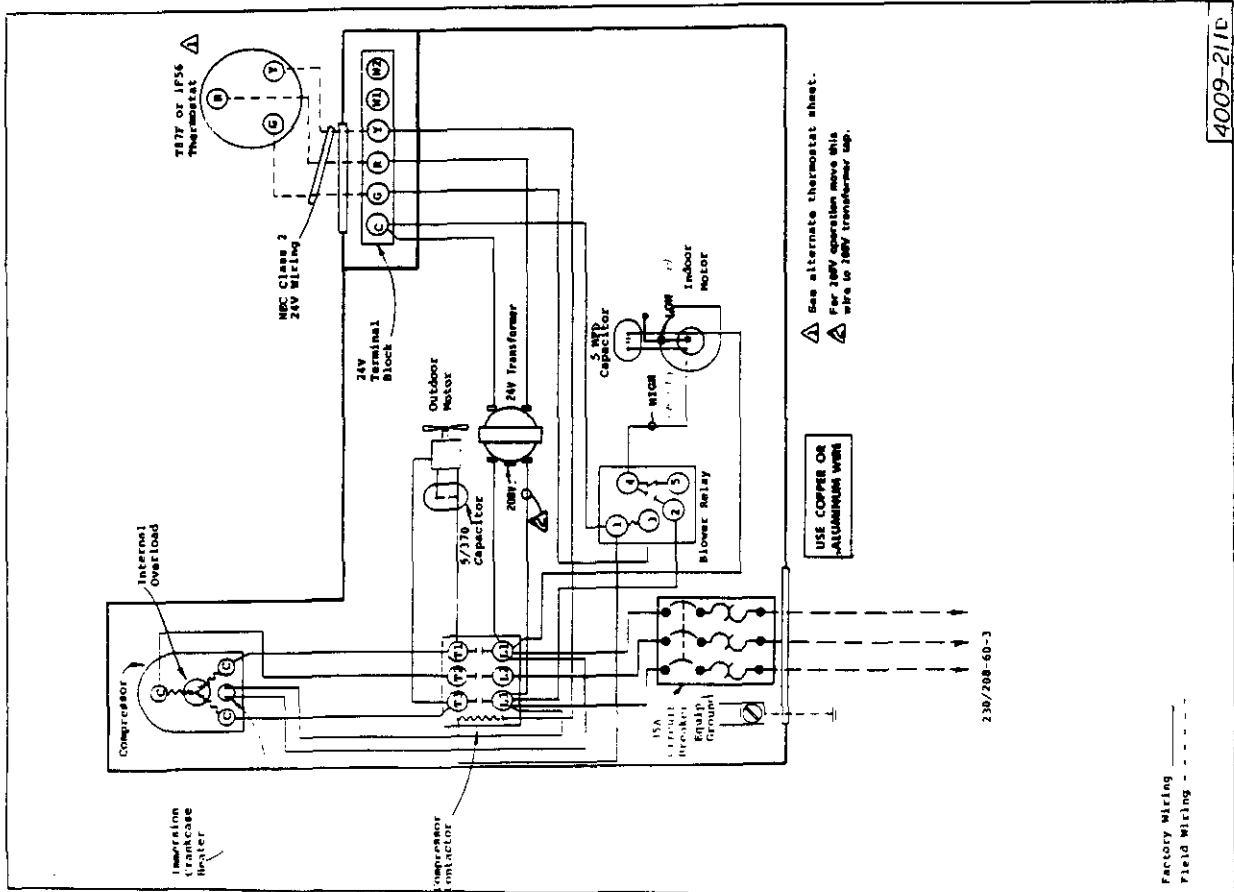

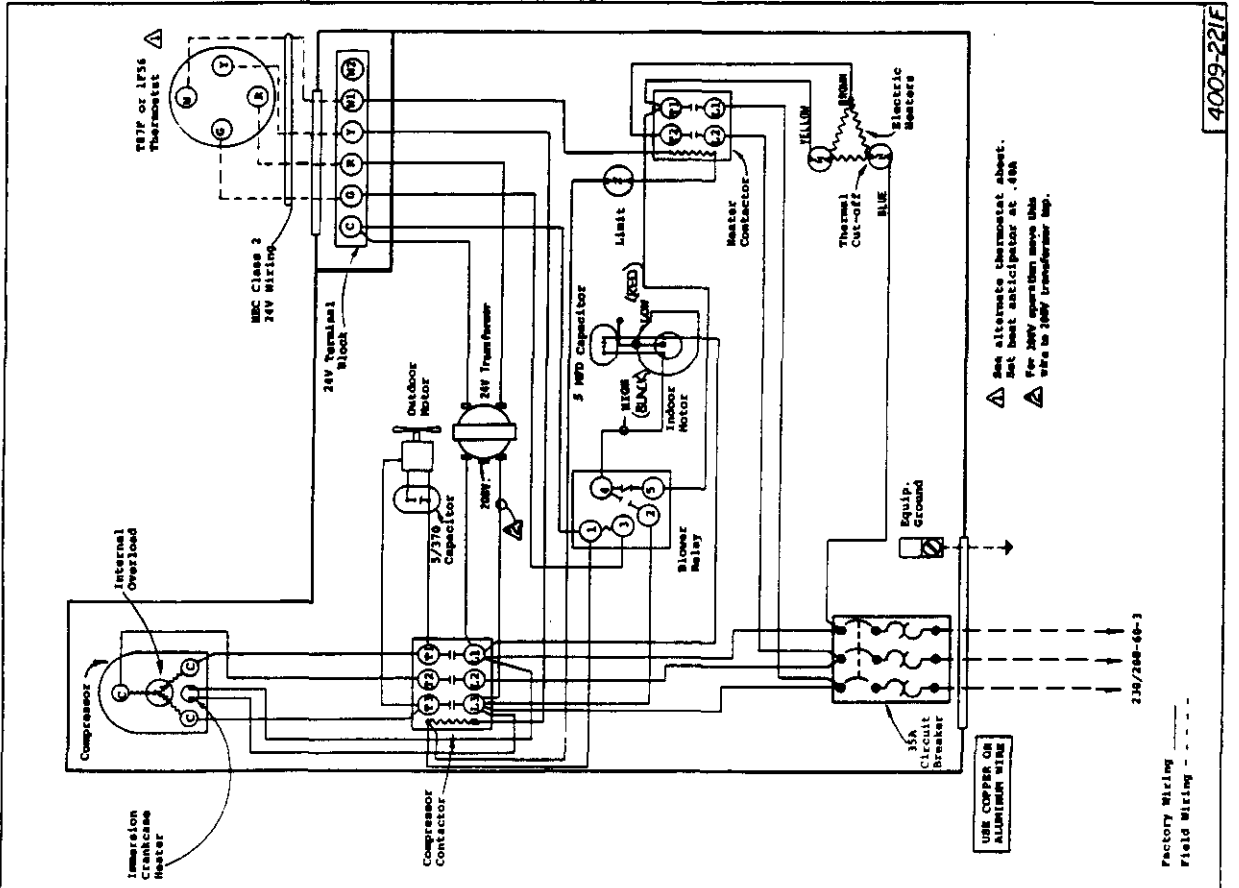

4009-221F

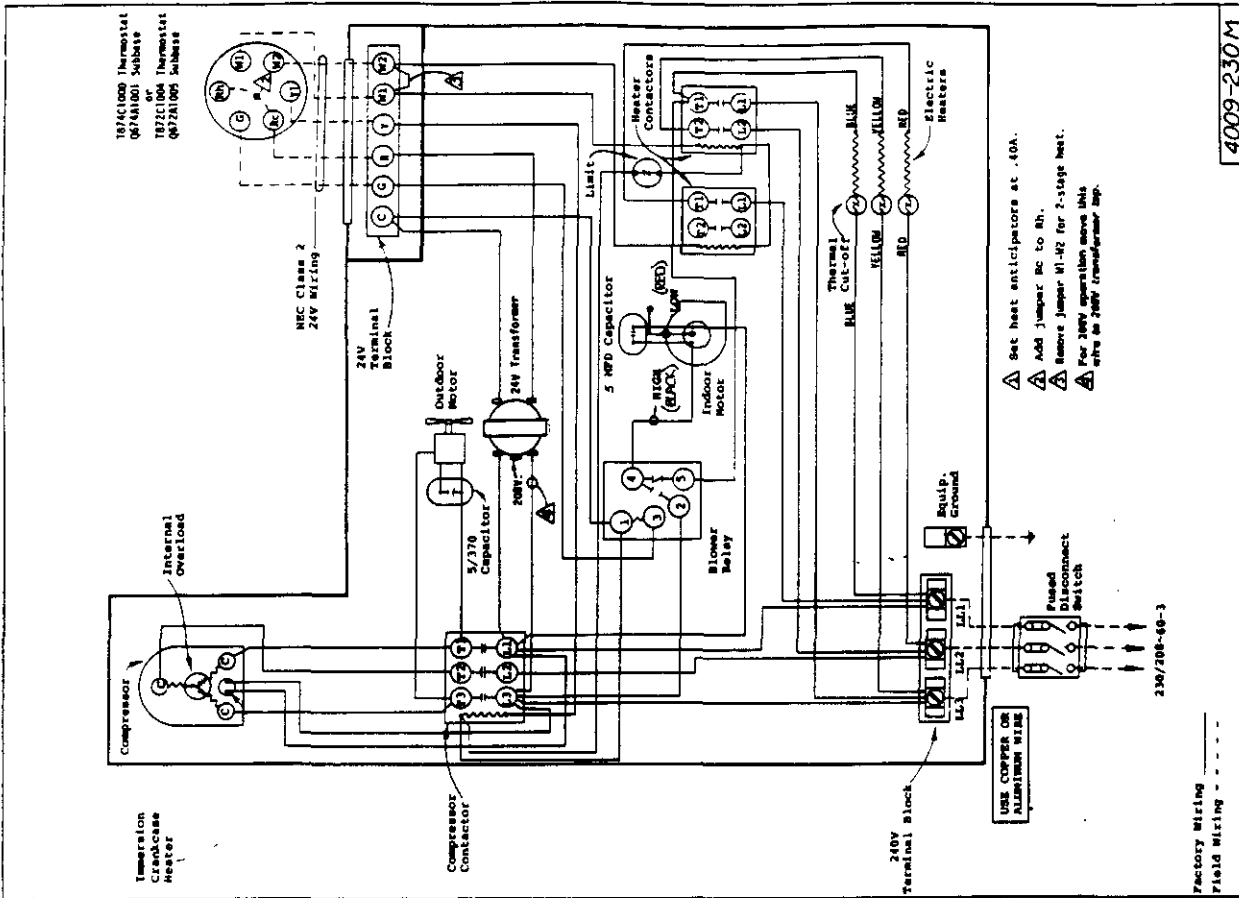

4009-230M

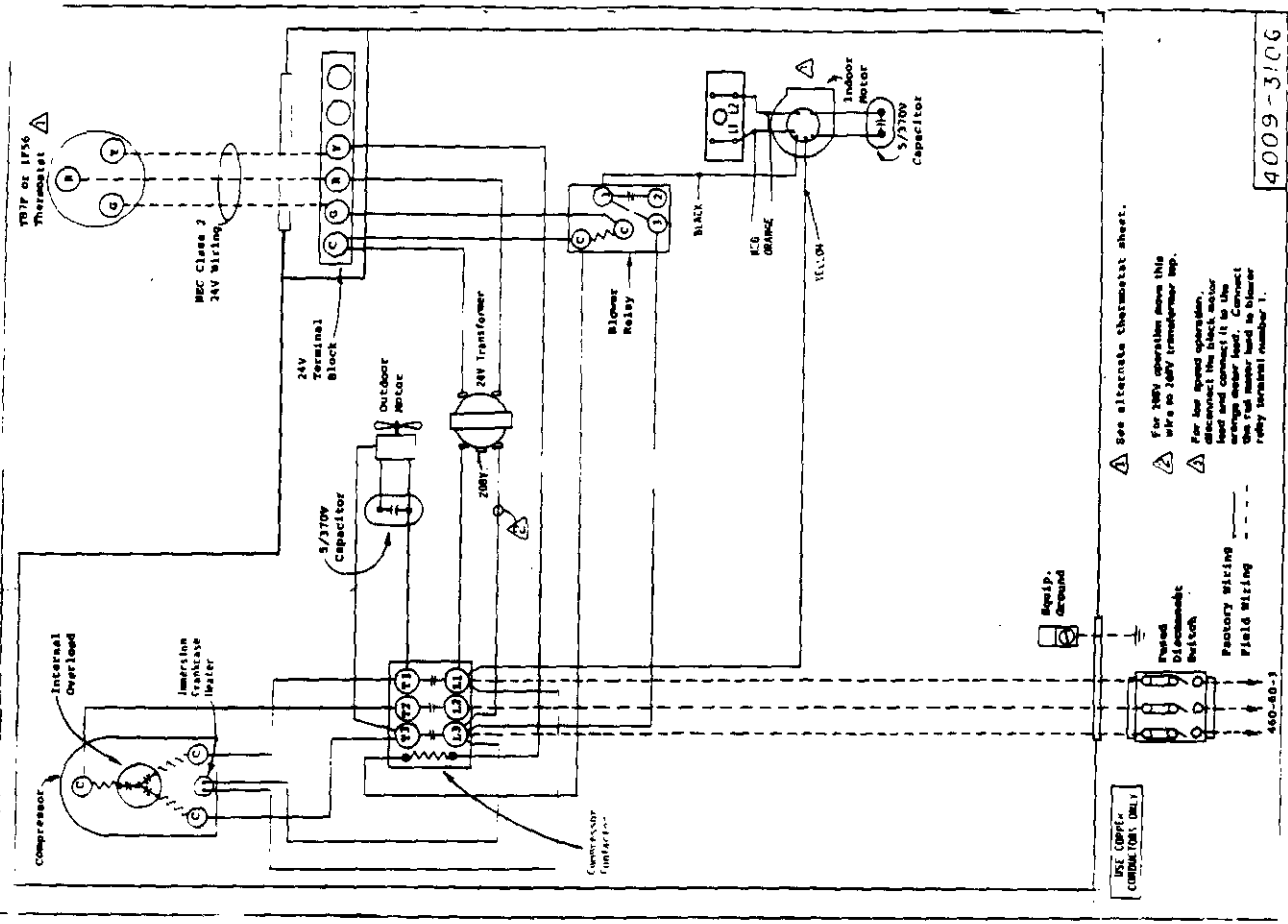

- See alternate thermostat sheet.
- For 200V operation move this wire to 24V transformer tap.
- For low speed operation, disconnect the blower motor lead and connect it to the wrong motor lead. Connect the wrong motor lead to blower relay terminal (number 1).

4009-3106

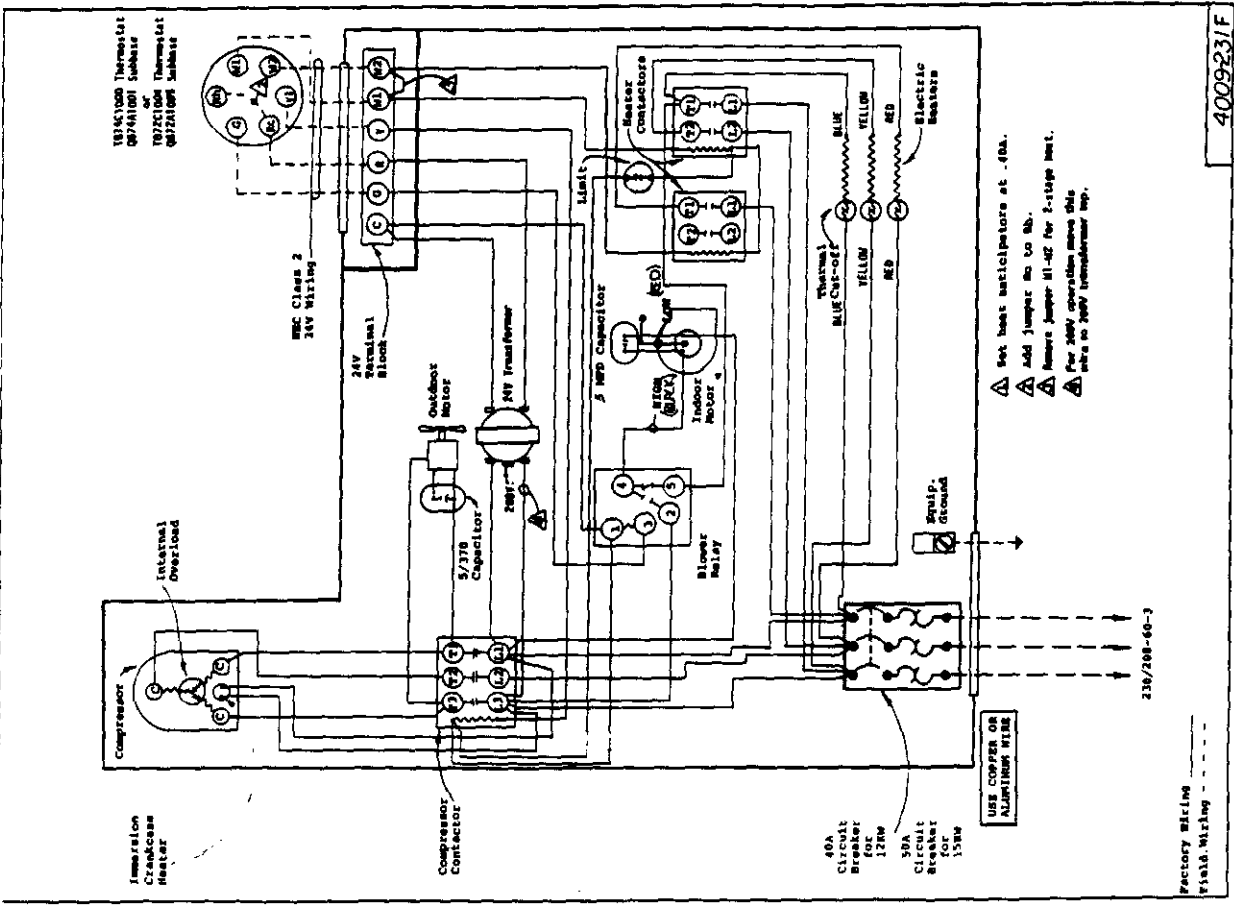

- Set heat anticipators at .60A.
- Add jumper as to 4b.
- Remove jumper 41-42 for 2-stage heat.
- For 200V operation move this wire to 200V transformer tap.

4009231F

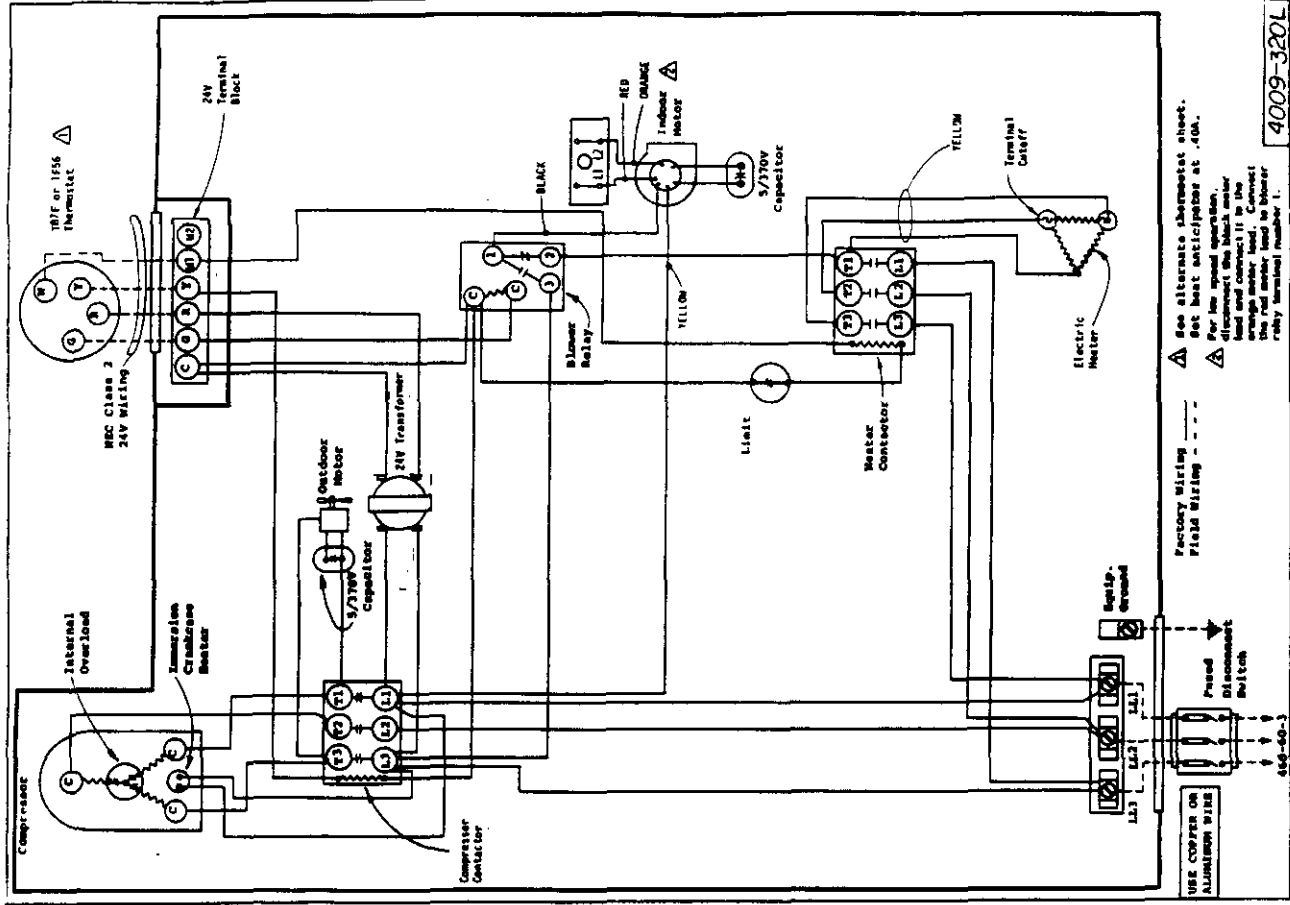
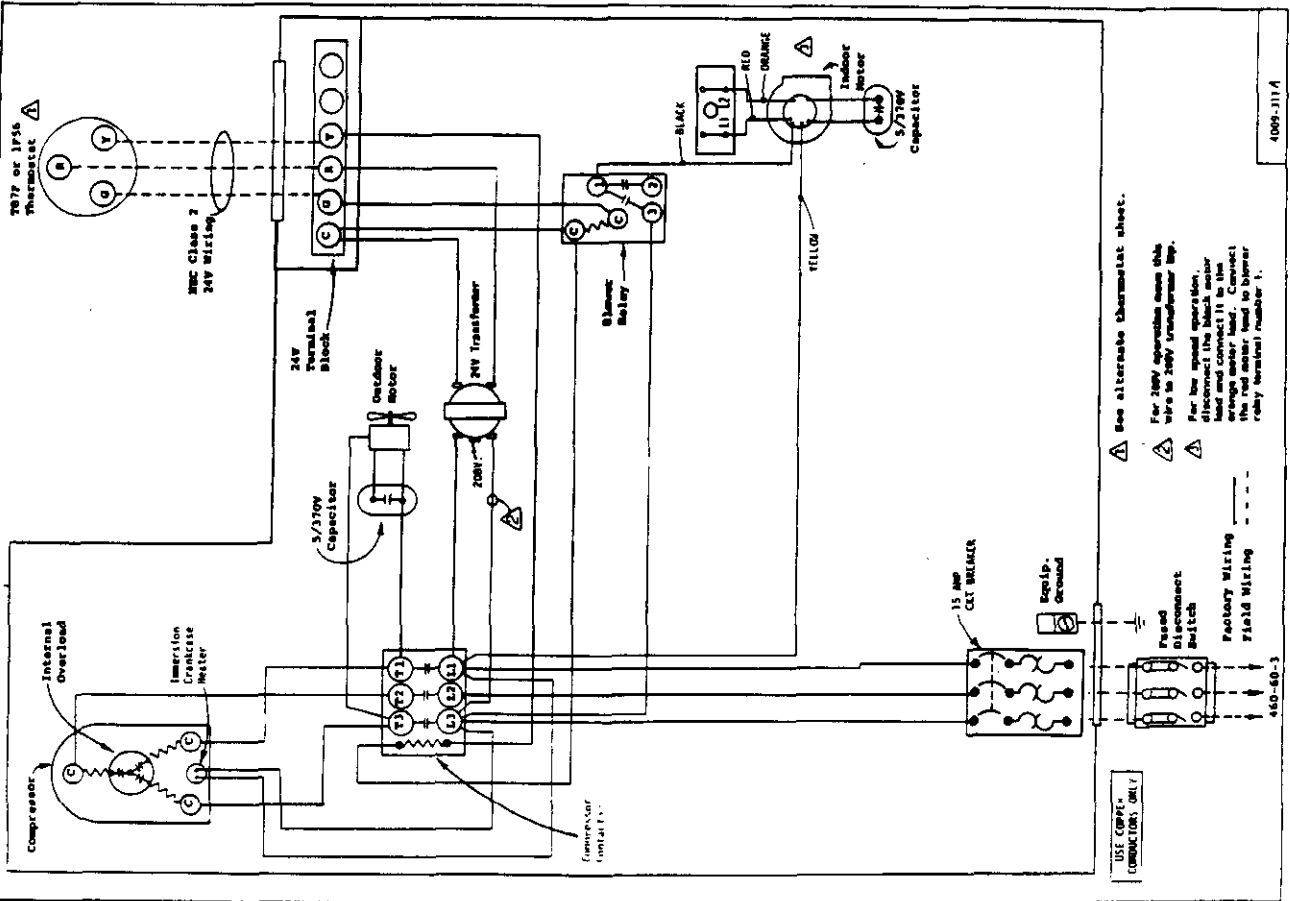

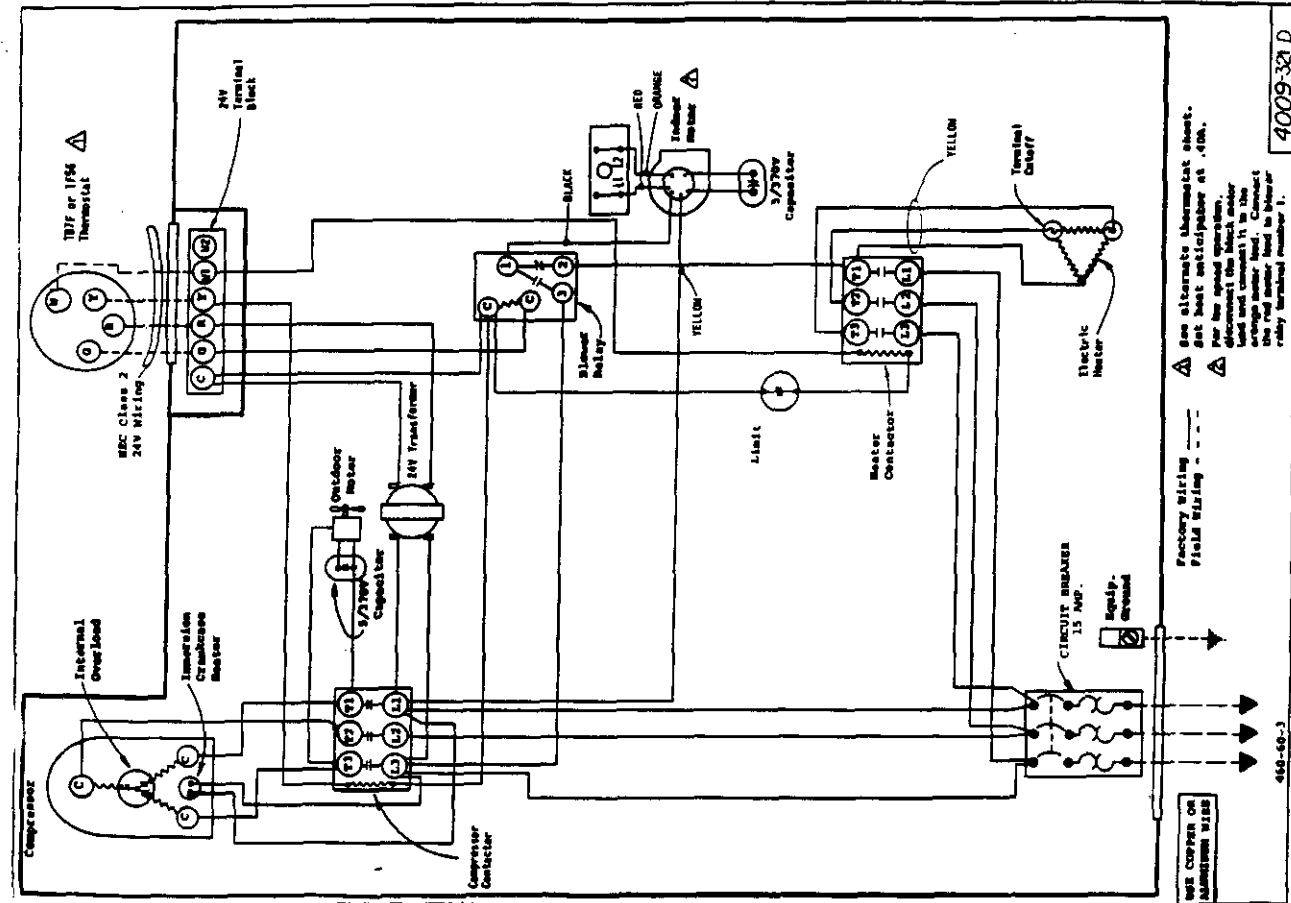

4009-32 D

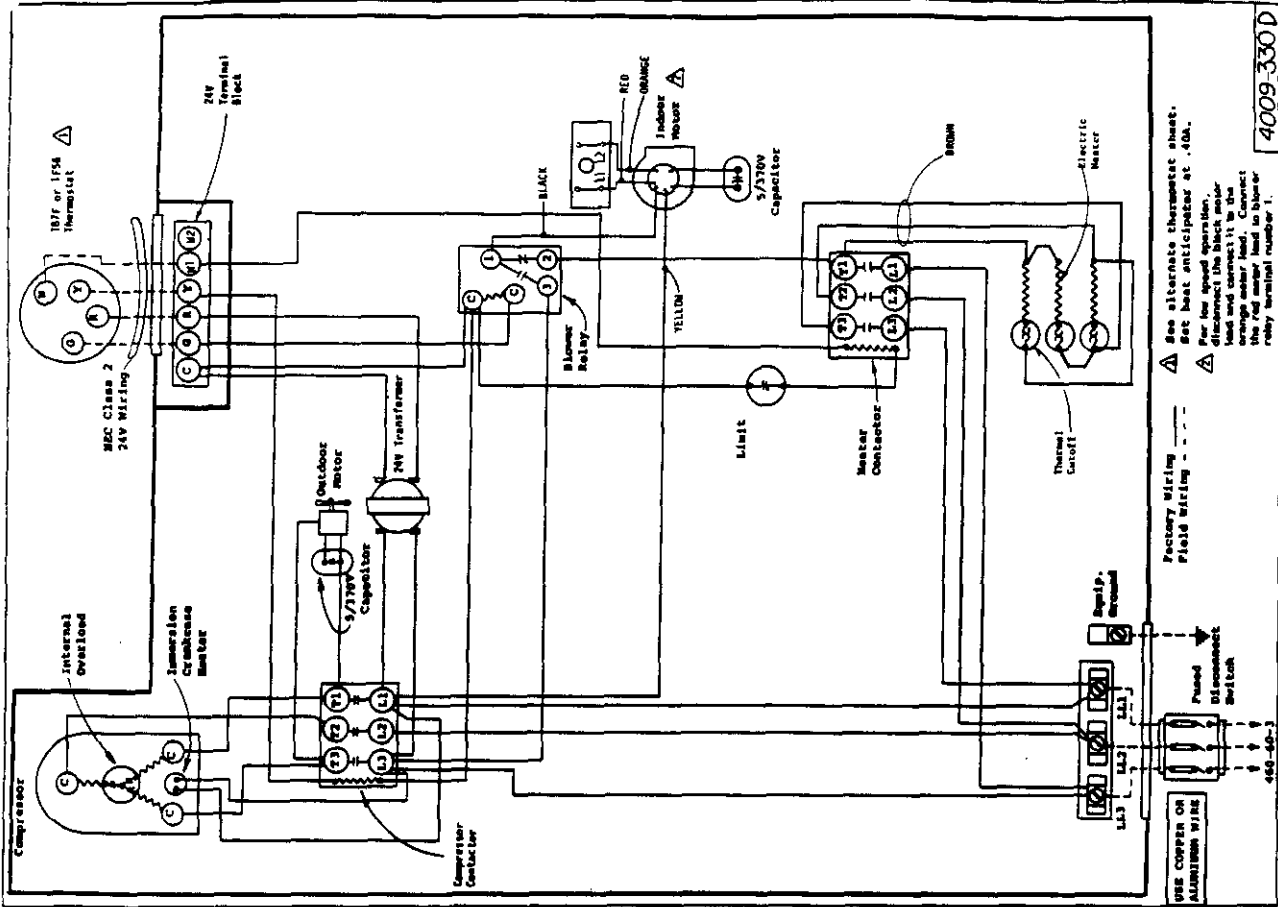

4009-330 D

