

INSTALLATION INSTRUCTIONS

**WALL MOUNTED
PACKAGE AIR CONDITIONERS**

MODELS

42WA

49WA

60WA

COPYRIGHT APRIL, 1989
BARD MANUFACTURING COMPANY
BRYAN, OHIO

ANSI

ANSI

ANSI

ANSI

ELECTRICAL INFORMATION										WIRING INFORMATION**		
Model	Rated Volts/Ph	Operating Voltage Range	Heater* KW	Max Unit Amps	No. Field Power Circuits	Internal Fuses		Required Overcurrent Protection	Minimum Circuit Ampacity	Field Power Wiring	Ground Wire Size	
						Ckt. A	Ckt. B					Ckt. A
42WA	230/208-1	197-253	0	27.3	1				50	33	8	10
			5	27.3	1				50	33	8	10
			10	45.6	1				60	57	4	10
			15	66.5	1	60	30		90	84	3	8
			20	87.2	1	60	60		110	109	1	6
42WA-B	230/208-3	187-253	0	19.8	1				35	24	10	10
			9	25.7	1				35	33	8	10
			12	32.9	1				45	41	6	10
			15	40.2	1				60	51	6	10
			18	47.4	1				60	60	4	10
42WA-C	460-3	414-506	0	11.4	1				20	15	14	14
			9	12.8	1				20	16	12	12
			12	16.2	1				25	21	10	10
			15	20	1				30	25	10	10
			18	23.7	1				35	30	8	10
49WA	230/208-1	197-253	0	28.8	1				50	35	8	10
			5	28.8	1				50	35	8	10
			10	45.6	1				60	57	4	10
			15	66.5	1	60	30		90	84	3	8
			20	87.2	1	60	60		110	109	1	6
49WA-B	230/208-3	187-253	0	20.8	1				35	25	10	10
			9	25.7	1				35	33	8	10
			12	32.9	1				45	41	6	10
			15	40.2	1				60	51	6	10
			18	47.4	1				60	60	4	10
49WA-C	460-3	414-506	0	11.4	1				20	15	14	14
			9	12.8	1				20	16	12	12
			12	16.4	1				25	21	10	10
			15	20	1				30	25	10	10
			18	23.7	1				35	30	8	10
60WA	230/208-1	197-253	0	32.8	1				60	44	6	10
			5	32.8	1				60	44	6	10
			10	45.6	1				60	57	4	10
			15	66.5	1	60	30		90	84	2	8
			20	87.2	1	60	60		110	109	1	6
60WA-B	230/208-3	187-253	0	24.3	1				45	29	8	10
			9	25.7	1				45	33	8	10
			12	32.9	1				45	41	6	10
			15	40.2	1				60	51	6	10
			18	47.4	1				60	60	4	10
60WA-C	460-3	414-506	0	12.4	1				20	15	14	14
			9	12.8	1				20	16	12	12
			12	16.4	1				20	21	10	10
			15	20.0	1				30	25	10	10
			18	23.7	1				35	30	8	10

*Electric heaters are nominal Kw @ 240V or 480V.
 **Based on 60°C copper wire. Other wiring materials must be rated for marked minimum circuit ampacity or greater. Not all models are approved for aluminum wire.

① Time delay fuses or "HACR Type" circuit breakers must be used for 60 and smaller sizes. Standard fuses or circuit breakers suitable for sizes 70 and larger.

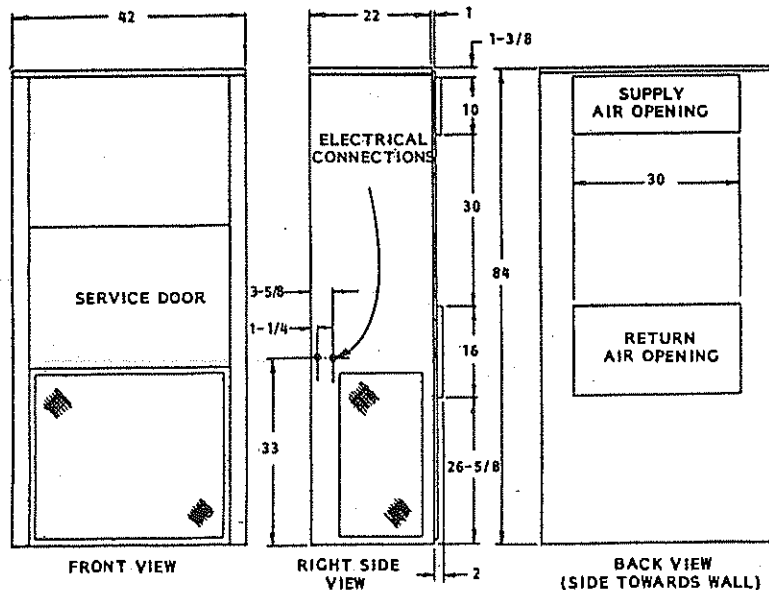

IMPORTANT

The equipment covered in this manual is to be installed by trained, experienced service and installation technicians. Any heat pump is more critical of proper operating, charge and an adequate duct system than a straight air conditioning unit. All duct work supply and return, must be properly sized for the design air flow requirement of the equipment. ACCA is an excellent guide to proper sizing. All duct work or portions thereof not in the conditioned space should be properly insulated in order to both conserve energy and prevent condensation or moisture damage.

SHIPPING DAMAGE

Upon receipt of equipment, the carton should be checked for external signs of shipping damage. If damage is found, the receiving party must contact the last carrier immediately, preferably in writing, requesting inspection by the carrier's agent.

GENERAL

The refrigerant system is completely assembled and charged. All internal wiring is complete.

The unit is designed for use with or without duct work. Flanges are provided for attaching the supply and return ducts.

These instructions explain the recommended method to install the air cooled self-contained unit and the electrical wiring connections to the unit.

These instructions and any instructions packaged with any separate equipment required to make up the entire air conditioning system should be carefully read before beginning the installation. Note particularly "Starting Procedure" and any tags and/or labels attached to the equipment.

While these instructions are intended as a general recommended guide, they do not supersede any national and/or local codes in any way. Authorities having jurisdiction should be consulted before the installation is made.

INSTALLATION

Size of unit for a proposed installation should be based on heat loss calculation made according to methods of Air Conditioning Contractors of America (ACCA). The air duct should be installed in accordance with the Standards of the National Fire Protection Association for the Installation of Air Conditioning and Ventilating systems for Other Than Residence Type, NFPA No. 90A, and Residence Type Warm Air Heating and Air Conditioning Systems, NFPA No. 90B. Where local regulations are at a variance with instructions, installer should adhere to local codes.

DUCT WORK

Design the duct work according to methods given by the Air Conditioning Contractors of America. When duct runs through unheated spaces, it should be insulated with a minimum of one inch of insulation. Use insulation with a vapor barrier on the outside of the insulation. Flexible joints should be used to connect the duct work to the equipment in order to keep the noise transmission to a minimum.

A one-inch clearance to combustible material for the first three feet of duct attached to the outlet air frame is required. See page 5 for further details.

FILTER

A one inch throwaway filter is supplied with each unit. The filter slides into position making it easy to service. This filter can be serviced from the outside by removing the service door.

FRESH AIR INTAKE

All units are built with a fresh air inlet hole punched in the service panel. The fresh air damper assembly is shipped with each unit, and must be attached at the installation site. See Figure 1 for typical installation procedure.

The fresh air damper assembly is standard equipment with the unit because of the variety of state or local codes requiring fresh air capability.

All capacity, efficiency and cost of operation information as required for Department of Energy "Energyguide" Fact Sheets is based upon the fresh air blank-off plate in place and is recommended for maximum energy efficiency.

The blank-off plate is available upon request from the factory and is installed in place of the fresh air damper shipped with each unit.

WALL MOUNTING

1. Two holes, the size of the supply and return air openings must be cut through the wall as shown in Figure 2.
2. On wood-frame walls, the wall construction must be strong and rigid enough to carry the weight of the unit without transmitting any unit vibration.
3. Concrete block walls must be thoroughly inspected to insure that they are capable of carrying the weight of the installing unit.
4. Ducts through the walls must be insulated and all joints taped or sealed to prevent air or moisture entering the wall cavity.
5. Some installations may not require any return air duct. It is recommended that on this type of installation that a filter grille be located in the wall. Filters must be of sufficient size to allow a maximum velocity of 400 FPM.

NOTE: If no return air duct is used, applicable installation codes may limit this cabinet to installation only in a single story structure.

WIRING - MAIN POWER

Refer to the unit rating plate for wire sizing information and maximum fuse or "HACR Type" circuit breaker size. Each outdoor unit is marked with a "Minimum Circuit Ampacity." This means that the field wiring used must be sized to carry that amount of current. Depending on the installed Kw of electric heat, there may be two field power circuits required. If this is the case, the unit serial plate will so indicate. Some models are suitable only for connection with copper wire, while others can be wired with either copper or aluminum wire. Each unit and/or wiring diagram will be marked "Use Copper Conductors Only" or "Use Copper or Aluminum Conductors." These instructions MUST BE adhered to. Refer to the National Electrical Code for complete current carrying capacity data on the various insulation grades of wiring material.

The electrical data lists fuse and wire sizes (60°F copper) for all models, including the most commonly used heater sizes. Also shown are the number of field power circuits required for the various models with heaters.

Field conduit connections must be to the control box and not terminate at the cabinet.

The unit rating plate lists a "Maximum Time Delay Fuse" or "HACR Type" circuit breaker that is to be used with the equipment. The correct size must be used for proper circuit protection and also to assure that there will be no nuisance tripping due to the momentary high starting current of the compressor motor.

PRESSURE SERVICE PORTS

High and low pressure service ports are installed on all units so that the system operating pressures can be observed. Pressure curves can be found later in the manual covering all models on both cooling and heating cycles. It is imperative to match the correct pressure curve to the unit by model number.

CRANKCASE HEATERS

All units are provided with some form of compressor crankcase heat. Some single phase units utilize the compressor motor start winding in series with a portion of the run capacitor to generate heat within the compressor shell to prevent liquid refrigerant migration.

Some three phase units utilize a wraparound type of crankcase heater that warms the compressor oil from the outside.

Some single and three phase models have an insertion well-type heater located in the lower section of the compressor housing. This is a self-regulating type heater that draws only enough power to maintain the compressor at a safe temperature.

Some form of crankcase heat is essential to prevent liquid refrigerant from migrating to the compressor, causing oil pump out on compressor start-up and possible valve failure due to compressing a liquid.

Refer to unit wiring diagram to find exact type of crankcase heater used.

The following decal is affixed to all outdoor units detailing start-up procedure. This is very important. Please read carefully.

IMPORTANT

THESE PROCEDURES MUST BE FOLLOWED AT INITIAL START-UP AND AT ANY TIME POWER HAS BEEN REMOVED FOR 12 HOURS OR LONGER.

TO PREVENT COMPRESSOR DAMAGE WHICH MAY RESULT FROM THE PRESENCE OF LIQUID REFRIGERANT IN THE COMPRESSOR CRANKCASE

1. MAKE CERTAIN THE ROOM THERMOSTAT IS IN THE "OFF" POSITION. (THE COMPRESSOR IS NOT TO OPERATE)
2. APPLY POWER BY CLOSING THE SYSTEM DISCONNECT SWITCH THIS ENERGIZES THE COMPRESSOR HEATER WHICH EVAPORATES THE LIQUID REFRIGERANT IN THE CRANKCASE.
3. ALLOW 4 HOURS OR 60 MINUTES PER POUND OF REFRIGERANT IN THE SYSTEM AS NOTED ON THE UNIT RATING PLATE, WHICHEVER IS GREATER.
4. AFTER PROPERLY ELAPSED TIME THE THERMOSTAT MAY BE SET TO OPERATE THE COMPRESSOR.
5. EXCEPT AS REQUIRED FOR SAFETY WHILE SERVICING - DO NOT OPEN SYSTEM DISCONNECT SWITCH.

7961-061

IMPORTANT INSTALLER NOTE

For improved start-up performance wash the indoor coil with a dishwasher detergent.

NOTE:

If this unit is operated in cooling below a 65° outdoor ambient temperature, the installation of low ambient control (LAC-1) to unit is required.

FAN BLADE SETTING DIMENSIONS

Shown in the drawing below are the correct fan blade setting dimensions for proper air delivery across the outdoor coil.

Any service work requiring removal or adjustment in the fan and/or motor area will require that the dimensions below be checked and blades adjusted in or out on the motor shaft accordingly.

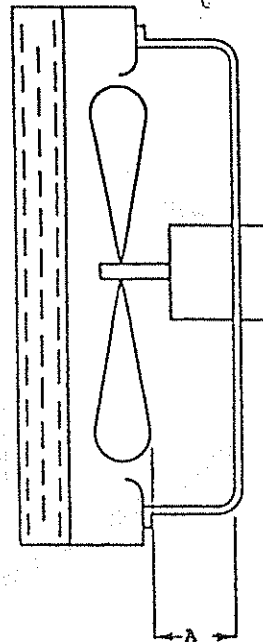

MODEL	DIM. A
42WA	1
49WA	2
60WA	2

REFRIGERANT CHARGE

The correct system R-22 charge is shown on the unit rating plate. Optimum unit performance will occur with a refrigerant charge resulting in a suction line temperature (6" from compressor) as shown in the following table:

MODEL	AIRFLOW	95°F OD Temp.	82°F OD Temp.
42WA	1575	57 - 59	67 - 69
49WA	1725	60 - 62	68 - 70
60WA	1700	54 - 56	63 - 65

The above suction line temperatures are based upon 80° dry bulb/67°F wet bulb (50% R.H.) temperature and rated airflow across the evaporator during cooling cycle.

RATED CFM AND E.S.P. (WET COIL-COOLING)			
MODEL	RATED CFM*	RATED E.S.P.*	RECOMMENDED AIRFLOW RANGE
42WA	1575	.40	1425 - 1700 CFM
49WA	1725	.30	1425 - 1900 CFM
60WA	1700	.20	1425 - 1900 CFM

*Rated CFM and E.S.P. on high speed tap.

INDOOR BLOWER PERFORMANCE CFM--DRY COIL WITH FILTER				
E.S.P. Inches H ₂ O	Models 42WA, 49WA		Model 60WA	
	Lbw	High	Low	High
.0	1475	2000	1495	2020
.1	1435	1875	1475	1915
.2	1380	1760	1430	1810
.3		1635		1700
.4		1460		1560
.5		1280		1415
.6		1100		1270

UNIT MODELS

20WA
24WA
18WH
24WH

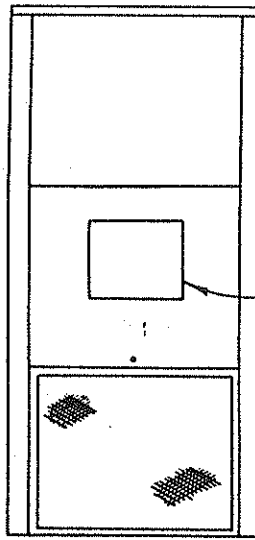

Model FAD10
Fresh Air Cover
With Adjustable
Damper

UNIT MODELS

30WA
36WA
30WH
36WH
42WA
49WA
60WA
48WH
60WH

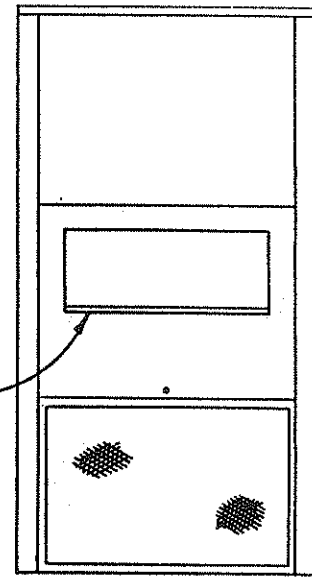

MODEL FAD25
Fresh Air Cover
With Adjustable
Damper

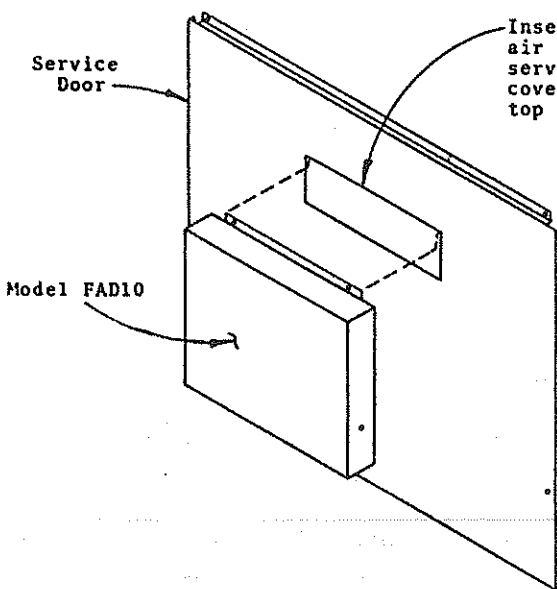

Insert top flange of fresh
air cover into opening in
service door and push top of
cover assembly all the way to
top of opening.

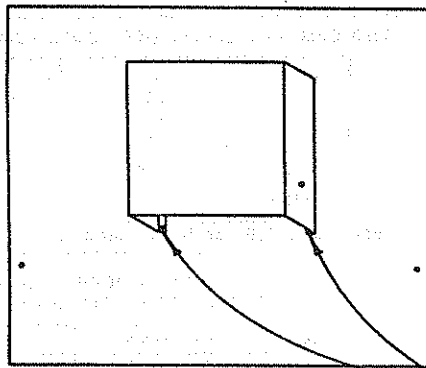
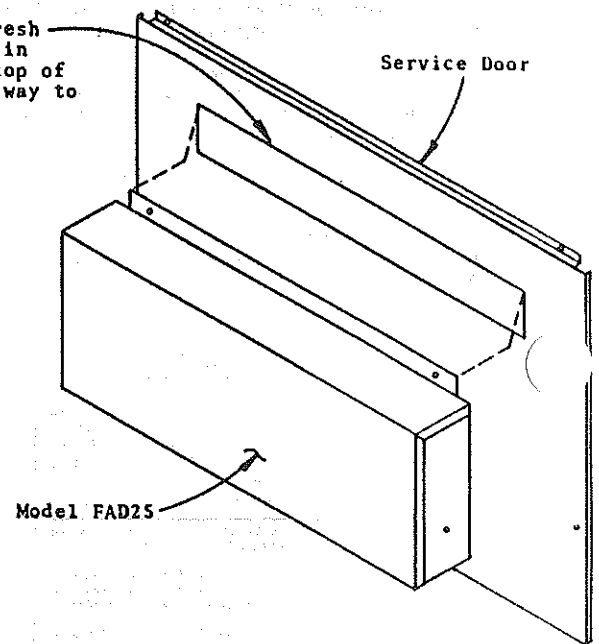

Secure bottom of
Fresh Air Cover Assembly
with two screws.

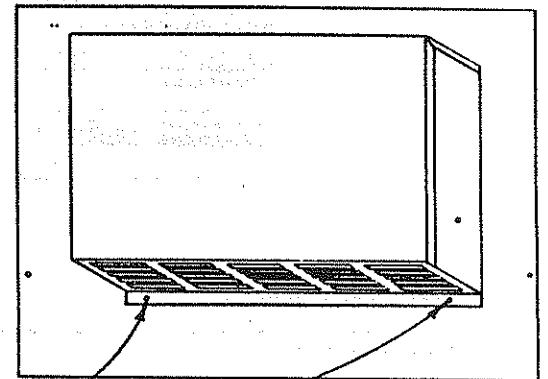
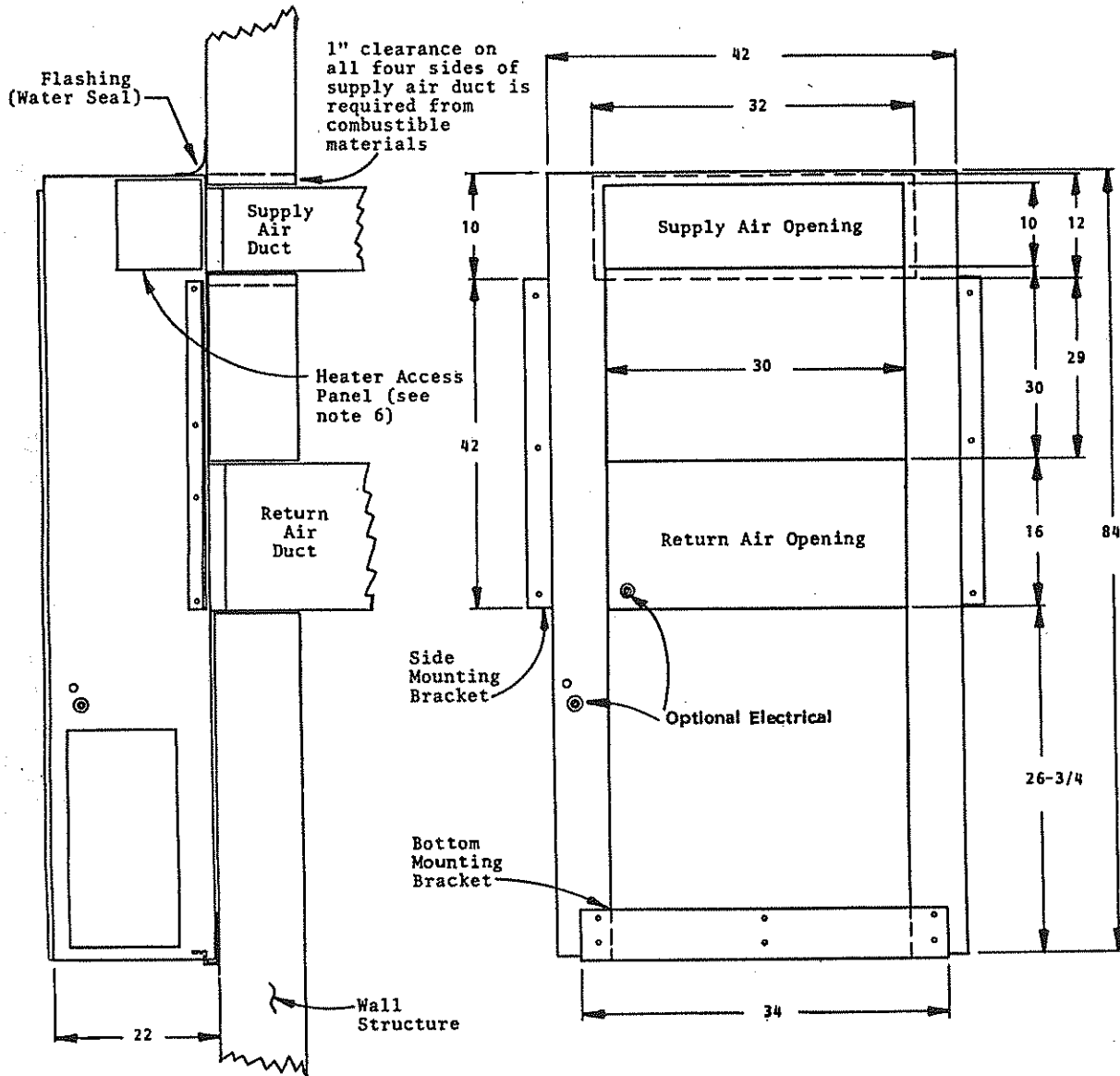

FIGURE 1

RIGHT SIDE VIEW

WALL VIEW



MOUNTING INSTRUCTIONS

1. These units are secured by wall mounting brackets which secure the unit to the outside wall surface at both sides and at the bottom.
2. The unit itself is suitable for "0" inch clearance, but the supply air duct flange and the first few feet of supply air duct require 1 inch clearance to combustible material. If combustible wall, use 30"x10" dimensions for sizing, if non-combustible, use 28"x8" dimensions.
3. After the wall opening positions have been selected, lay out the position for the bottom and side brackets. Fasten the brackets securely to the wall (type of fasteners will depend on wall construction).
4. Be sure to observe the 10" dimension when attaching the side brackets. This will assure that no screws are driven into the unit sides damaging any internal parts. One-half inch sheet metal screws are recommended.
5. For additional mounting rigidity, the return air and supply air (depending upon wall construction) frames or collars can be drilled and screwed or welded to the structural wall itself. Be sure to observe required clearance if combustible wall.
6. Maintain 30 inches minimum clearance on right side of unit to allow access to heat strip.

These curves are based upon 80°DB, 67°WB R.A. Temp. and rated CFM (airflow) across the evaporator coil and should be used for reference purposes only. Special information can be found under section titled "Refrigerant Charge" elsewhere in manual. If there is any doubt as to correct operating charge being in the system, the charge should be removed, system evacuated, and recharged according to serial plate instructions.

HIGH SIDE (DISCHARGE LINE) PRESSURE -- PSIG

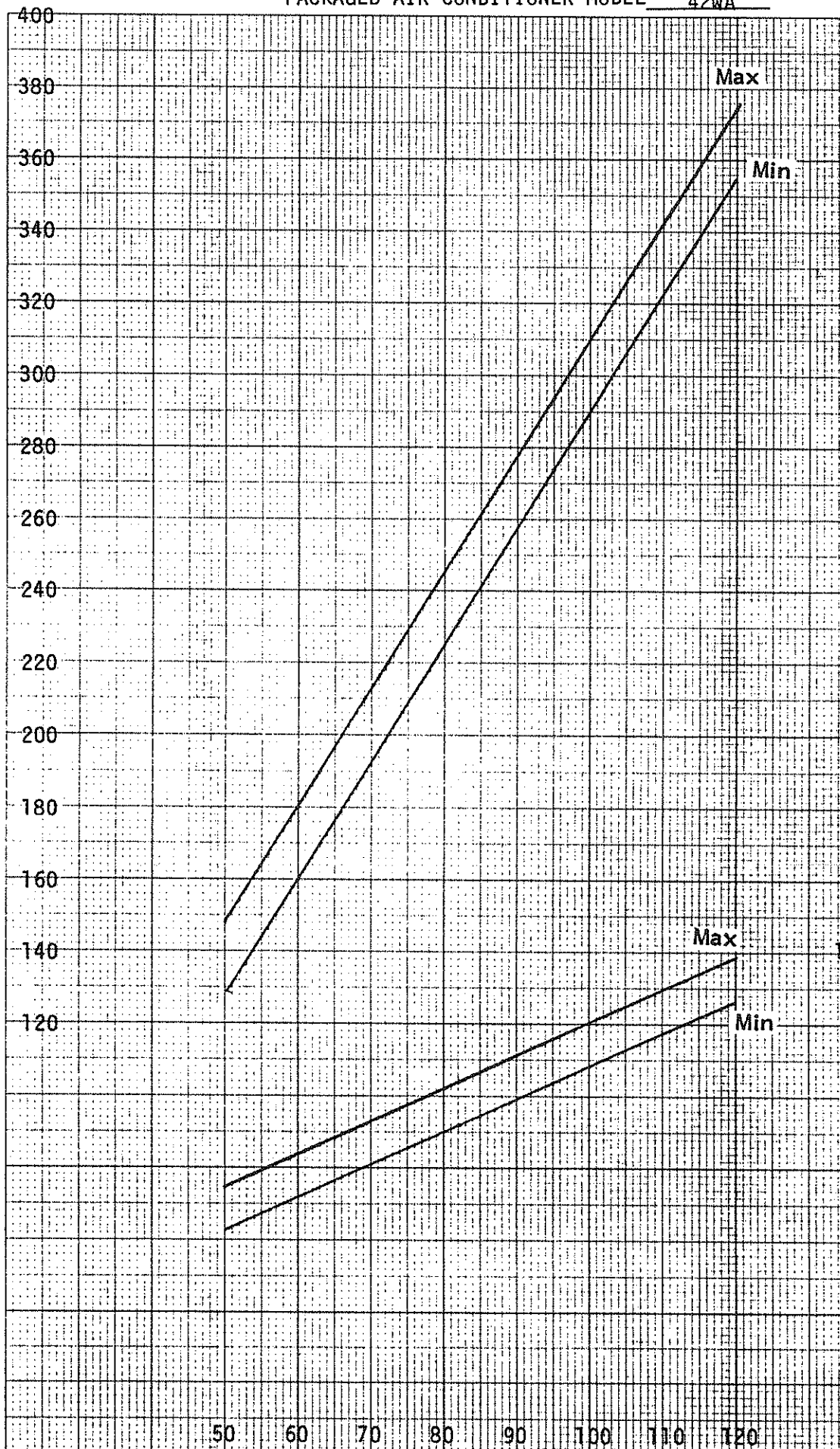

LOW SIDE PRESSURE--PSIG (SUCTION LINE)

AIR TEMPERATURE ENTERING OUTDOOR COIL - DEGREE F.

These curves are based upon 80°DB, 67°WB R.A. Temp. and rated CFM (airflow) across the evaporator coil and should be used for reference purposes only. Special information can be found under section titled "Refrigerant Charge" elsewhere in manual. If there is any doubt as to correct operating charge being in the system, the charge should be removed, system evacuated, and recharged according to serial plate instructions.

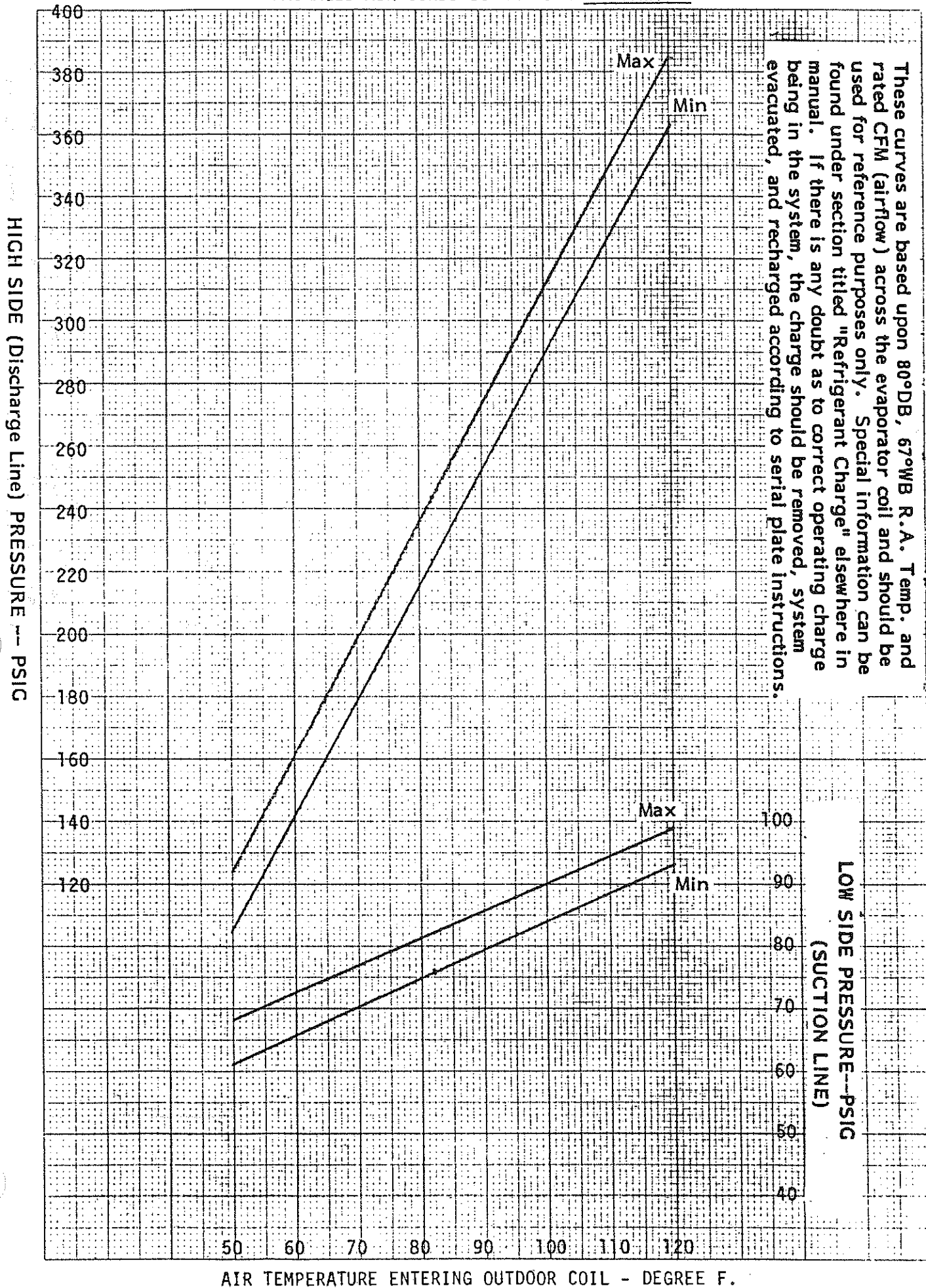

AIR TEMPERATURE ENTERING OUTDOOR COIL - DEGREE F.

HIGH SIDE (Discharge Line) PRESSURE -- PSIG

LOW SIDE PRESSURE--PSIG (SUCTION LINE)

APR 11 1964

APR 11 1964

PACKAGED AIR CONDITIONER MODEL 60WA

85

These curves are based upon 80°DB, 67°WB R.A. Temp. and rated Capacity (airflow) across the evaporator coil and should be used for reference purposes only. Special information can be found under section titled "Refrigerant Charge" elsewhere in manual. If there is any doubt as to correct operating charge being in the system, the charge should be removed, system evacuated, and recharged according to serial plate instructions.

HIGH SIDE (DISCHARGE LINE) PRESSURE--PSIG

LOW SIDE PRESSURE--PSIG
(SUCTION LINE)

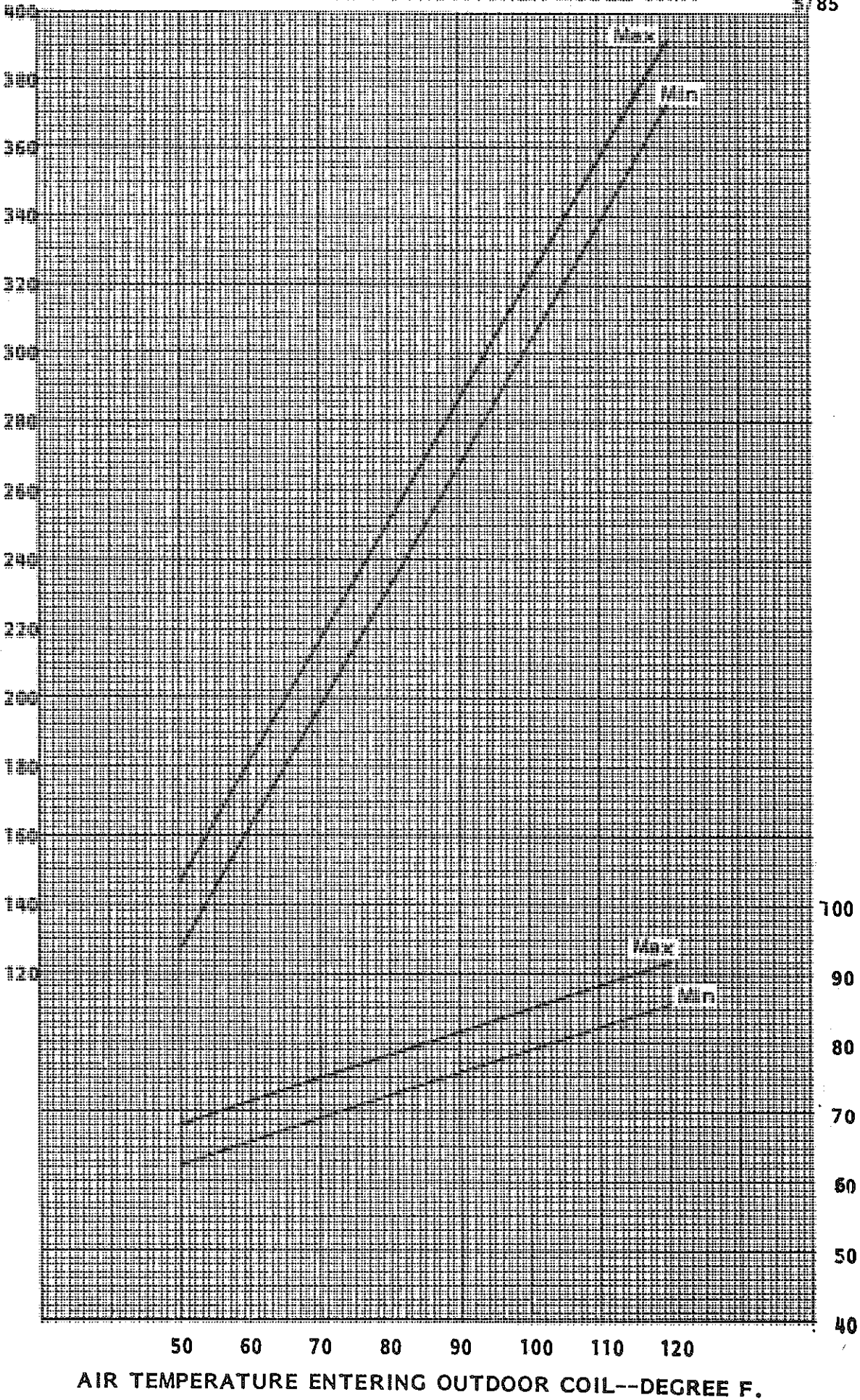

AIR TEMPERATURE ENTERING OUTDOOR COIL--DEGREE F.

PARTS LIST
SINGLE PACKAGE AIR CONDITIONERS

1/88

Part No.	Description	42WA-A00N	42WA-A10N	42WA-A15N	42WA-A20N	42WA-A00C	42WA-A10C	42WA-A15C	42WA-A20C
*	Blower Housing								
5152-011	Blower Wheel DD10-8A	x	x	x	x	x	x	x	x
5152-012	Blower Wheel DD10-8A	x	x	x	x	x	x	x	x
8552-028	Capacitor - Compressor 35/440V	x	x	x	x	x	x	x	x
8552-005	Capacitor - Blower 10/370V	x	x	x	x	x	x	x	x
8552-026	Capacitor - Fan 15/370V	x	x	x	x	x	x	x	x
5811-021	Capillary Tube - Cool	2	2	2	2	2	2	2	2
8000-058	Compressor CRJ3-0300	x	x	x	x	x	x	x	x
5051-027	Condenser Coil	x	x	x	x	x	x	x	x
8401-003	Contactors - Compressor 1P30A	x	x	x	x	x	x	x	x
8401-016	Contactors - 1P35A		1	2	2		1	2	2
8615-015	Circuit Breaker					1			
8615-016	Circuit Breaker						1	1	2
8615-013	Circuit Breaker							1	
5151-027	Fan Blade B2430-4-ccw	x	x	x	x	x	x	x	x
7004-016	Filter 20x30	x	x	x	x	x	x	x	x
8614-022	Fuse 60A			2	2				
8614-006	Fuse 30A			2					
8614-007	Fuse 60A				2				
8614-017	Fuse Block 15kw			x					
8614-018	Fuse Block 20kw				x				
8604-044	Heat Strip 10kw		1		2		1		2
8604-047	Heat Strip 15kw			1				1	
8402-047	Limit Switch L180-7		1	1	1		1	1	1
8106-023	Motor - Blower 1/2 hp	x	x	x	x	x	x	x	x
8105-021	Motor - Fan 1/3 hp	x	x	x	x	x	x	x	x
8201-009	Relay - Blower	x	x	x	x	x	x	x	x
8200-004	Motor Mount - Fan	x	x	x	x	x	x	x	x
5210-005	Strainer	x	x	x	x	x	x	x	x
8607-018	Terminal Board 24V	x	x	x	x	x	x	x	x
8607-013	Terminal Block 230V	x	x						
8402-032	Thermal Cutoff		2	3	4		2	3	4
8407-034	Transformer 40VA	x	x	x	x	x	x	x	x
4010-110	Wiring Diagram	x							
4010-111	Wiring Diagram					x			
4010-130	Wiring Diagram		x						
4010-131	Wiring Diagram						x		
4010-140	Wiring Diagram			x					
4010-141	Wiring Diagram							x	
4010-150	Wiring Diagram				x				
4010-151	Wiring Diagram								x
5060-025	Evaporator Coil	x	x	x	x	x	x	x	x

*Please order by model number.

PARTS LIST
SINGLE PACKAGE AIR CONDITIONERS

1/88

Part No.	Description	42WA-B00N	42WA-B09N	42WA-B15N	42WA-B18N	42WA-B00C	42WA-B09C	42WA-B15C	42WA-B18C
*	Blower Housing	x	x	x	x	x	x	x	x
5152-011	Blower Wheel DD10-8A	x	x	x	x	x	x	x	x
5152-012	Blower Wheel DD10-8A	x	x	x	x	x	x	x	x
8552-005	Capacitor - Blower 10/370V	x	x	x	x	x	x	x	x
8552-026	Capacitor - Fan 15/370V	x	x	x	x	x	x	x	x
5811-021	Capillary Tube - Cool	2	2	2	2	2	2	2	2
8000-059	Compressor CRJ3-0300	x	x	x	x	x	x	x	x
5051-027	Condenser Coil	x	x	x	x	x	x	x	x
8401-002	Contactora - 3P25A	x	x	x	x	x	x	x	x
8401-006	Contactora - Heater 24V	1	2	2	2	1	2	2	2
8615-019	Circuit Breaker					1	1		
8615-011	Circuit Breaker							1	1
5060-025	Evaporator Coil	x	x	x	x	x	x	x	x
5151-027	Fan Blade B2430-4 ccw.	x	x	x	x	x	x	x	x
7004-016	Filter 20x30	x	x	x	x	x	x	x	x
8604-047	Heat Strip 15kw			x				x	
8604-048	Heat Strip 9kw		1		2		1		2
8402-047	Limit Switch L180-7		1	1	1		1	1	1
8106-023	Motor - Blower 1/2 hp	x	x	x	x	x	x	x	x
8105-021	Motor - Fan 1/3 hp	x	x	x	x	x	x	x	x
8201-009	Relay - Blower	x	x	x	x	x	x	x	x
8200-004	Motor Mount - Fan	x	x	x	x	x	x	x	x
5210-005	Strainer	x	x	x	x	x	x	x	x
8607-018	Terminal Board 24V	x	x	x	x	x	x	x	x
8607-014	Terminal Block 230V	x	x	x	x	x	x	x	x
8402-032	Thermal Cutoff		2	3	3		2	3	3
8407-034	Transformer 40VA	x	x	x	x	x	x	x	x
4010-210	Wiring Diagram	x							
4010-211	Wiring Diagram					x			
4010-220	Wiring Diagram		x						
4010-221	Wiring Diagram						x		
4010-230	Wiring Diagram			x					
4010-231	Wiring Diagram							x	
4010-240	Wiring Diagram				x				
4010-241	Wiring Diagram								x

*Please order by model number.

PARTS LIST
SINGLE PACKAGE AIR CONDITIONERS

1/88

Part No.	Description	49WA-A00N	49WA-A10N	49WA-A15N	49WA-A20N	49WA-A00C	49WA-A10C	49WA-A15C	49WA-A20C	49WA-A00H	49WA-A10H	49WA-A20H
*	Blower Housing	x	x	x	x	x	x	x	x	x	x	x
5152-011	Blower Wheel DD10-8A	x	x	x	x	x	x	x	x	x	x	x
5152-012	Blower Wheel DD10-8A	x	x	x	x	x	x	x	x	x	x	x
8552-005	Capacitor - Blower 10/370V	x	x	x	x	x	x	x	x	x	x	x
8552-026	Capacitor - Fan 15/370V	x	x	x	x	x	x	x	x	x	x	x
8552-030	Capacitor - Compressor 40/440V	x	x	x	x	x	x	x	x	x	x	x
5811-020	Capillary Tube - Cool	2	2	2	2	2	2	2	2			
8000-063	Compressor CRK3-0325	x	x	x	x	x	x	x	x	x	x	x
5051-028	Condenser Coil	x	x	x	x	x	x	x	x	x	x	x
8401-006	Contactor - Heater 24V		1	2	2		1	2	2		1	2
8401-003	Contactor - Compressor 1P30A	1	1	1	1	1	1	1	1	1	1	1
8615-015	Circuit Breaker					1						
8615-016	Circuit Breaker						1	1	2			
8615-013	Circuit Breaker											
5060-025	Evaporator Coil	x	x	x	x	x	x	x	x	x	x	x
5151-027	Fan Blade B2430-4 ccw	x	x	x	x	x	x	x	x	x	x	x
7004-016	Filter 20x30	x	x	x	x	x	x	x	x	x	x	x
8614-022	Fuse 60A			2	2							2
8614-006	Fuse 30A			2								
8614-007	Fuse 60A				2							2
8614-017	Fuse Block 15kw			1								
8614-018	Fuse Block 20kw				1							1
8604-044	Heat Strip 10kw		1		2		1		2		1	2
8604-047	Heat Strip 15kw			1				1				
8402-047	Limit Switch L180-7		x	x	x		x	x	x		x	x
8106-023	Motor - Blower 1/2 hp	x	x	x	x	x	x	x	x	x	x	x
8105-021	Motor - Fan 1/3 hp	x	x	x	x	x	x	x	x	x	x	x
8201-009	Relay - Blower	x	x	x	x	x	x	x	x	x	x	x
8200-004	Motor Mount - Fan	x	x	x	x	x	x	x	x	x	x	x
5210-005	Strainer	x	x	x	x	x	x	x	x			
8607-018	Terminal Board 24V	x	x	x	x	x	x	x	x	x	x	x
8607-013	Terminal Block 230V	x	x							x	x	
8402-032	Thermal Cutoff		2	3	4		2	3	4		2	4
8407-034	Transformer 40VA	x	x	x	x	x	x	x	x	x	x	x
4010-110	Wiring Diagram	x								x		
4010-111	Wiring Diagram					x						
4010-130	Wiring Diagram		x								x	
4010-131	Wiring Diagram						x					
4010-140	Wiring Diagram			x								
4010-141	Wiring Diagram							x				
4010-150	Wiring Diagram				x							
4010-151	Wiring Diagram								x			x

*Please order by model number.

PARTS LIST
SINGLE PACKAGE AIR CONDITIONERS

1/88

Part No.	Description	49WA-B00N	49WA-B09N	49WA-B15N	49WA-B18N	49WA-B00C	49WA-B90C	49WA-B15C	49WA-B18C	49WA-B00H	49WA-B09H	49WA-B18H
*	Blower Housing	x	x	x	x	x	x	x	x	x	x	x
5152-011	Blower Wheel DD10-8A	x	x	x	x	x	x	x	x	x	x	x
5152-012	Blower Wheel DD10-8A	x	x	x	x	x	x	x	x	x	x	x
8552-005	Capacitor - Blower 10/370V	x	x	x	x	x	x	x	x	x	x	x
8552-026	Capacitor - Fan 15/370V	x	x	x	x	x	x	x	x	x	x	x
5811-020	Capillary Tube - Cool	2	2	2	2	2	2	2	2			
8000-064	Compressor CRK3-0325	x	x	x	x	x	x	x	x	x	x	x
5051-028	Condenser Coil	x	x	x	x	x	x	x	x	x	x	x
8401-002	Contactora - 3P25A	1	1	1	1	1	1	1	1	1	1	1
8401-006	Contactora - Heater 24V		1	2	2		1	2	2		1	2
8615-019	Circuit Breaker					1	1					
8615-011	Circuit Breaker							1	1			
5060-025	Evaporator Coil	x	x	x	x	x	x	x	x	x	x	x
5151-027	Fan Blade B2430-4 ccw	x	x	x	x	x	x	x	x	x	x	x
7004-016	Filter 20x30	x	x	x	x	x	x	x	x	x	x	x
8604-047	Heat Strip 15kw			1				1				
8604-048	Heat Strip 9kw		1		2		1		2		1	2
8402-047	Limit Switch L180-7		x	x	x		x	x	x		x	x
8106-023	Motor - Blower 1/2 hp	x	x	x	x	x	x	x	x	x	x	x
8105-021	Motor - Fan 1/3 hp	x	x	x	x	x	x	x	x	x	x	x
8200-004	Motor Mount - Fan	x	x	x	x	x	x	x	x	x	x	x
8201-009	Relay - Blower	x	x	x	x	x	x	x	x	x	x	x
5210-005	Strainer	x	x	x	x	x	x	x	x			
8607-018	Terminal Board 24V	x	x	x	x	x	x	x	x	x	x	x
8607-014	Terminal Block 230V	x	x	x	x					x	x	x
8402-032	Thermal Cutoff		2	3	4		2	3	4		2	4
8407-034	Transformer 40VA	x	x	x	x	x	x	x	x	x	x	x
4010-210	Wiring Diagram	x								x		
4010-211	Wiring Diagram					x						
4010-220	Wiring Diagram		x								x	
4010-221	Wiring Diagram						x					
4010-230	Wiring Diagram			x								
4010-231	Wiring Diagram							x				
4010-240	Wiring Diagram				x							x
4010-241	Wiring Diagram								x			

*Please order by model number.

PARTS LIST
SINGLE PACKAGE AIR CONDITIONERS

1/88

Part No.	Description	49WA-C00N	49WA-C09N	49WA-C15N	49WA-C18N	49WA-C00C	49WA-C09C	49WA-C15C	49WA-C18C	49WA-C00H	49WA-C09H	49WA-C18H
*	Blower Housing	x	x	x	x	x	x	x	x	x	x	x
5152-011	Blower Wheel DD10-8A	x	x	x	x	x	x	x	x	x	x	x
5152-012	Blower Wheel DD10-8A	x	x	x	x	x	x	x	x	x	x	x
8552-005	Capacitor - Blower 10/370V	x	x	x	x	x	x	x	x	x	x	x
8552-026	Capacitor - Fan 15/370V	x	x	x	x	x	x	x	x	x	x	x
5811-020	Capillary Tube - Cool	2	2	2	2	2	2	2	2			
8000-065	Compressor CRK3-0325	x	x	x	x	x	x	x	x	x	x	x
5051-028	Condenser Coil	x	x	x	x	x	x	x	x	x	x	x
8401-002	Contacto - 3P25A	1	2	2	3	1	2	2	3	1	2	3
8615-024	Circuit Breaker					1	1					
8615-026	Circuit Breaker							1				
8615-027	Circuit Breaker								1			
5060-025	Evaporator Coil	x	x	x	x	x	x	x	x	x	x	x
5151-027	Fan Blade B2430-4 ccw	x	x	x	x	x	x	x	x	x	x	x
7004-016	Filter 20x30	x	x	x	x	x	x	x	x	x	x	x
8604-050	Heat Strip 9kw		1				1				1	
8604-052	Heat Strip 15kw			1				1				
8604-087	Heat Strip 18kw 460v				2				2			2
8402-047	Limit Switch L180-7		x	x	x		x	x	x		x	x
8106-024	Motor - Blower	x	x	x	x	x	x	x	x	x	x	x
8105-030	Motor - Fan	x	x	x	x	x	x	x	x	x	x	x
8200-004	Motor Mount - Fan	x	x	x	x	x	x	x	x	x	x	x
8201-032	Relay - Blower	x	x	x	x	x	x	x	x	x	x	x
5210-005	Strainer	x	x	x	x	x	x	x	x			
8607-018	Terminal Board 24V	x	x	x	x	x	x	x	x	x	x	x
8607-014	Terminal Block 230V	x	x	x	x					x	x	x
8402-032	Thermal Cutoff		3	3	6		3	3	6		3	6
8607-015	Phenolic Insulator	x	x	x	x					x	x	x
8407-027	Transformer 48VA	x	x	x	x	x	x	x	x	x	x	x
4010-310	Wiring Diagram	x								x		
4010-311	Wiring Diagram					x						
4010-320	Wiring Diagram		x	x							x	
4010-321	Wiring Diagram						x	x				
4010-330	Wiring Diagram				x							
4010-331	Wiring Diagram								x			x

* Please order by model number.

PARTS LIST
SINGLE PACKAGE AIR CONDITIONERS

1/88

Part No.	Description	60WA-A00N	60WA-A10N	60WA-A15N	60WA-A20N	60WA-A00C	60WA-A10C	60WA-A15C	60WA-A20C	60WA-A00H	60WA-A10H	60WA-A20H
*	Blower Housing	x	x	x	x	x	x	x	x	x	x	x
5152-011	Blower Wheel DD10-8A	x	x	x	x	x	x	x	x	x	x	x
5152-012	Blower Wheel DD10-8A	x	x	x	x	x	x	x	x	x	x	x
8552-005	Capacitor - Blower 10/370V	x	x	x	x	x	x	x	x	x	x	x
8552-026	Capacitor - Fan 15/370V	x	x	x	x	x	x	x	x	x	x	x
8552-031	Capacitor - Compressor 45/440V	x	x	x	x	x	x	x	x	x	x	x
5811-032	Capillary Tube - Cool	2	2	2	2	2	2	2	2			
8000-091	Compressor H23A543ABCA	x	x	x	x	x	x	x	x	x	x	x
5051-028	Condenser Coil	x	x	x	x	x	x	x	x	x	x	x
8401-006	Contactor - Heater 24V		1	2	2		1	2	2		1	2
8401-016	Contactor - 1P35A	x	x	x	x	x	x	x	x	x	x	x
8615-016	Circuit Breaker					1	1	1	2			
8615-013	Circuit Breaker							1				
5060-039	Evaporator Coil	x	x	x	x	x	x	x	x	x	x	x
5151-027	Fan Blade B2430-4 ccw	x	x	x	x	x	x	x	x	x	x	x
7004-016	Filter 20x30	x	x	x	x	x	x	x	x	x	x	x
8614-022	Fuse 60A			2	2							2
8614-006	Fuse 30A			2								2
8614-007	Fuse 60A				2							2
8614-017	Fuse Block 15kw			1								
8614-018	Fuse Block 20kw				1							1
8604-044	Heat Strip 10kw		1		2		1		2		1	2
8604-047	Heat Strip 15kw			1				1				
8402-047	Limit Switch L180-7		x	x	x		x	x	x		x	x
8106-023	Motor - Blower 1/2 hp	x	x	x	x	x	x	x	x	x	x	x
8105-021	Motor - Fan 1/3 hp	x	x	x	x	x	x	x	x	x	x	x
8200-004	Motor Mount - Fan	x	x	x	x	x	x	x	x	x	x	x
8201-009	Relay - Blower	x	x	x	x	x	x	x	x	x	x	x
5210-005	Strainer	x	x	x	x	x	x	x	x			
8607-018	Terminal Board 24V	x	x	x	x	x	x	x	x	x	x	x
8607-013	Terminal Block 230V	x	x							x	x	
8402-032	Thermal Cutoff		2	3	4		2	3	4		2	4
8407-034	Transformer 40VA	x	x	x	x	x	x	x	x	x	x	x
4010-110	Wiring Diagram	x								x		
4010-111	Wiring Diagram					x						
4010-130	Wiring Diagram		x								x	
4010-131	Wiring Diagram						x					
4010-140	Wiring Diagram			x								
4010-141	Wiring Diagram							x				
4010-150	Wiring Diagram				x							x
4010-151	Wiring Diagram								x			

*Please order by model number.

PARTS LIST
SINGLE PACKAGE AIR CONDITIONERS

1/88

Part No.	Description	60WA-B00N	60WA-B09N	60WA-B15N	60WA-B18N	60WA-B00C	60WA-B09C	60WA-B15C	60WA-B18C	6-WA-B00H	60WA-B09H	60WA-B18H
*	Blower Housing	x	x	x	x	x	x	x	x	x	x	x
5152-011	Blower Wheel DD10-8A	x	x	x	x	x	x	x	x	x	x	x
5152-012	Blower Wheel DD10-8A	x	x	x	x	x	x	x	x	x	x	x
8552-005	Capacitor - Blower 10/370V	x	x	x	x	x	x	x	x	x	x	x
8552-026	Capacitor - Fan 15/370V	x	x	x	x	x	x	x	x	x	x	x
5811-032	Capillary Tube - Cool	2	2	2	2	2	2	2	2			
8000-031	Compressor AG122RT	x	x	x	x	x	x	x	x	x	x	x
5051-028	Condenser Coil	x	x	x	x	x	x	x	x			
8401-006	Contactora - Heater 24V		1	2	2		1	2	2		1	2
8401-011	Contactora 3P30A	x	x	x	x	x	x	x	x	x	x	x
8615-021	Circuit Breaker					1	1					
8615-011	Circuit Breaker							1	1			
5060-039	Evaporator Coil	x	x	x	x	x	x	x	x	x	x	x
5151-027	Fan Blade B2430-4 ccw	x	x	x	x	x	x	x	x	x	x	x
7004-016	Filter 20x30	x	x	x	x	x	x	x	x	x	x	x
8604-047	Heat Strip 15kw			1				1				
8604-048	Heat Strip 9kw		1	x	2		1		2		1	2
8402-047	Limit Switch L180-7		x	x	x		x	x	x		x	x
8106-023	Motor - Blower 1/2 hp	x	x	x	x	x	x	x	x	x	x	x
8105-021	Motor - Fan 1/3 hp	x	x	x	x	x	x	x	x	x	x	x
8200-004	Motor Mount - Fan	x	x	x	x	x	x	x	x	x	x	x
8201-009	Relay - Blower	x	x	x	x	x	x	x	x	x	x	x
5210-005	Strainer	x	x	x	x	x	x	x	x			
8607-018	Terminal Board 24V	x	x	x	x	x	x	x	x	x	x	x
8607-014	Terminal Block 230V	x	x	x	x					x	x	x
8402-032	Thermal Cutoff		2	3	4		2	3	4		2	4
8407-034	Transformer 40VA	x	x	x	x	x	x	x	x	x	x	x
4010-210	Wiring Diagram	x								x		
4010-211	Wiring Diagram					x						
4010-220	Wiring Diagram		x								x	
4010-221	Wiring Diagram						x					
4010-230	Wiring Diagram			x								
4010-231	Wiring Diagram							x				
4010-240	Wiring Diagram				x							x
4010-241	Wiring Diagram								x			

*Please order by model number.

PARTS LIST
SINGLE PACKAGE AIR CONDITIONERS

1/88

Part No.	Description	60WA-C00N	60WA-C09N	60WA-C15N	60WA-C18N	60WA-C00C	60WA-C09C	60WA-C15C	60WA-C18C	60WA-C00H	60WA-C09H	60WA-C18H
*	Blower Housing	x	x	x	x	x	x	x	x	x	x	x
5152-011	Blower Wheel DD10-8A	x	x	x	x	x	x	x	x	x	x	x
5152-012	Blower Wheel DD10-8A	x	x	x	x	x	x	x	x	x	x	x
8552-005	Capacitor - Blower 10/370V	x	x	x	x	x	x	x	x	x	x	x
8552-026	Capacitor - Fan 15/370V	x	x	x	x	x	x	x	x	x	x	x
5811-032	Capillary Tube - Cool	2	2	2	2	2	2	2	2			
8000-048	Compressor AG122UT	x	x	x	x	x	x	x	x	x	x	x
5051-028	Condenser Coil	x	x	x	x	x	x	x	x	x	x	x
8401-002	Contactors - 3P25A	1	2	2	3	1	2	2	3	1	2	3
8615-024	Circuit Breaker					1	1					
8615-026	Circuit Breaker							1				
8615-027	Circuit Breaker								1			
5060-039	Evaporator Coil	x	x	x	x	x	x	x	x	x	x	x
5151-027	Fan Blade B2430-4 ccw	x	x	x	x	x	x	x	x	x	x	x
7004-016	Filter 20x30	x	x	x	x	x	x	x	x	x	x	x
8604-050	Heat Strip 9kw		1				1				1	
8604-052	Heat Strip 15kw			1				1				
8604-087	Heat Strip 18kw 460v				2				2			2
8402-047	Limit Switch L180-7		x	x	x		x	x	x		x	x
8106-024	Motor - Blower	x	x	x	x	x	x	x	x	x	x	x
8105-030	Motor - Fan	x	x	x	x	x	x	x	x	x	x	x
8200-004	Motor Mount - Fan	x	x	x	x	x	x	x	x	x	x	x
8201-032	Relay - Blower	x	x	x	x	x	x	x	x	x	x	x
8607-015	Phenolic Insulator	x	x	x	x					x	x	x
5210-005	Strainer	x	x	x	x	x	x	x	x			
8607-018	Terminal Board 24V	x	x	x	x	x	x	x	x	x	x	x
8607-014	Terminal Block 230V	x	x	x	x					x	x	x
8402-032	Thermal Cutoff		3	3	6		3	3	6		3	6
8407-027	Transformer 48VA	x	x	x	x	x	x	x	x	x	x	x
4010-310	Wiring Diagram	x								x		
4010-311	Wiring Diagram					x						
4010-320	Wiring Diagram		x	x							x	
4010-321	Wiring Diagram						x	x				
4010-330	Wiring Diagram				x							x
4010-331	Wiring Diagram								x			

*Please order by model number.

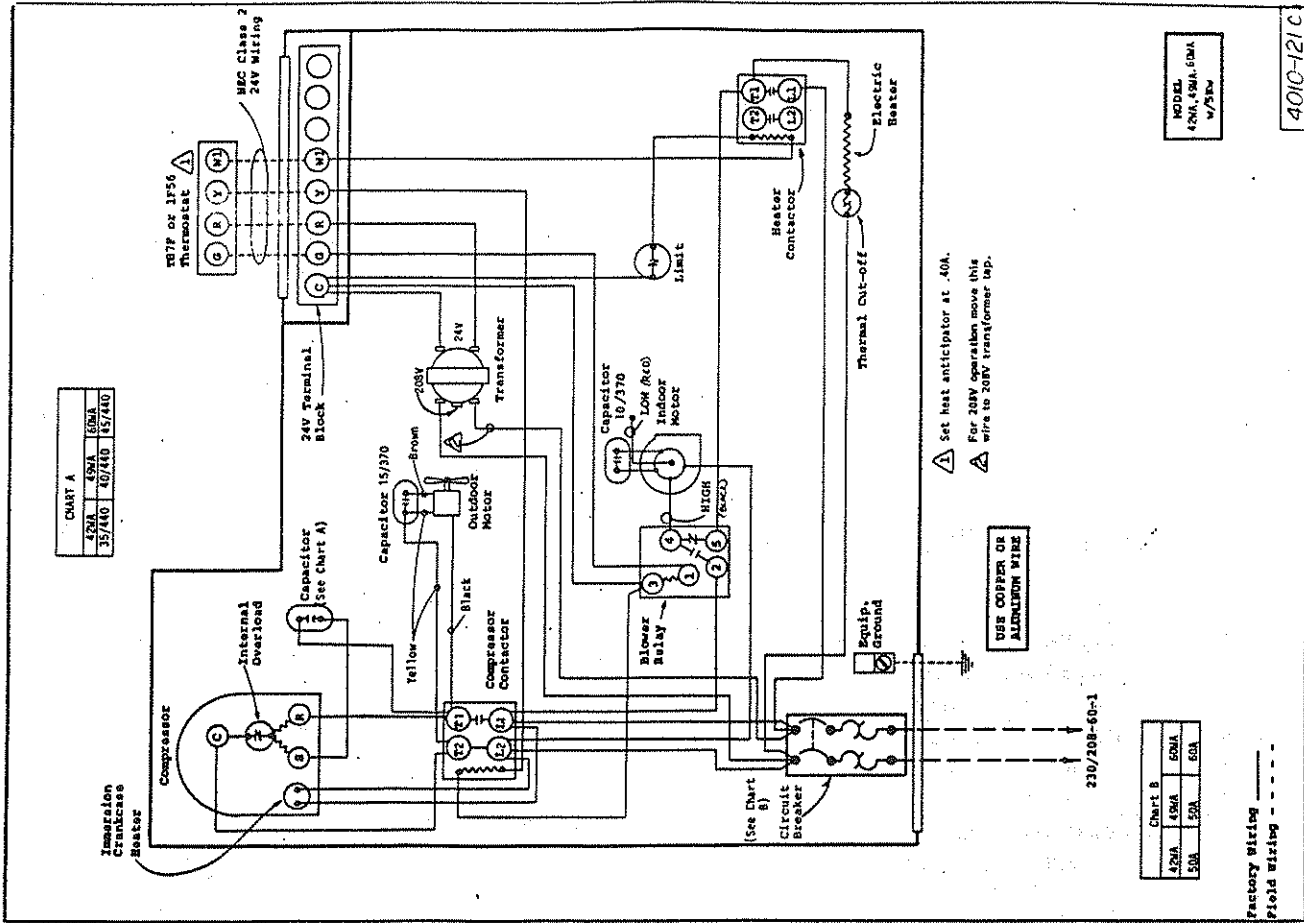
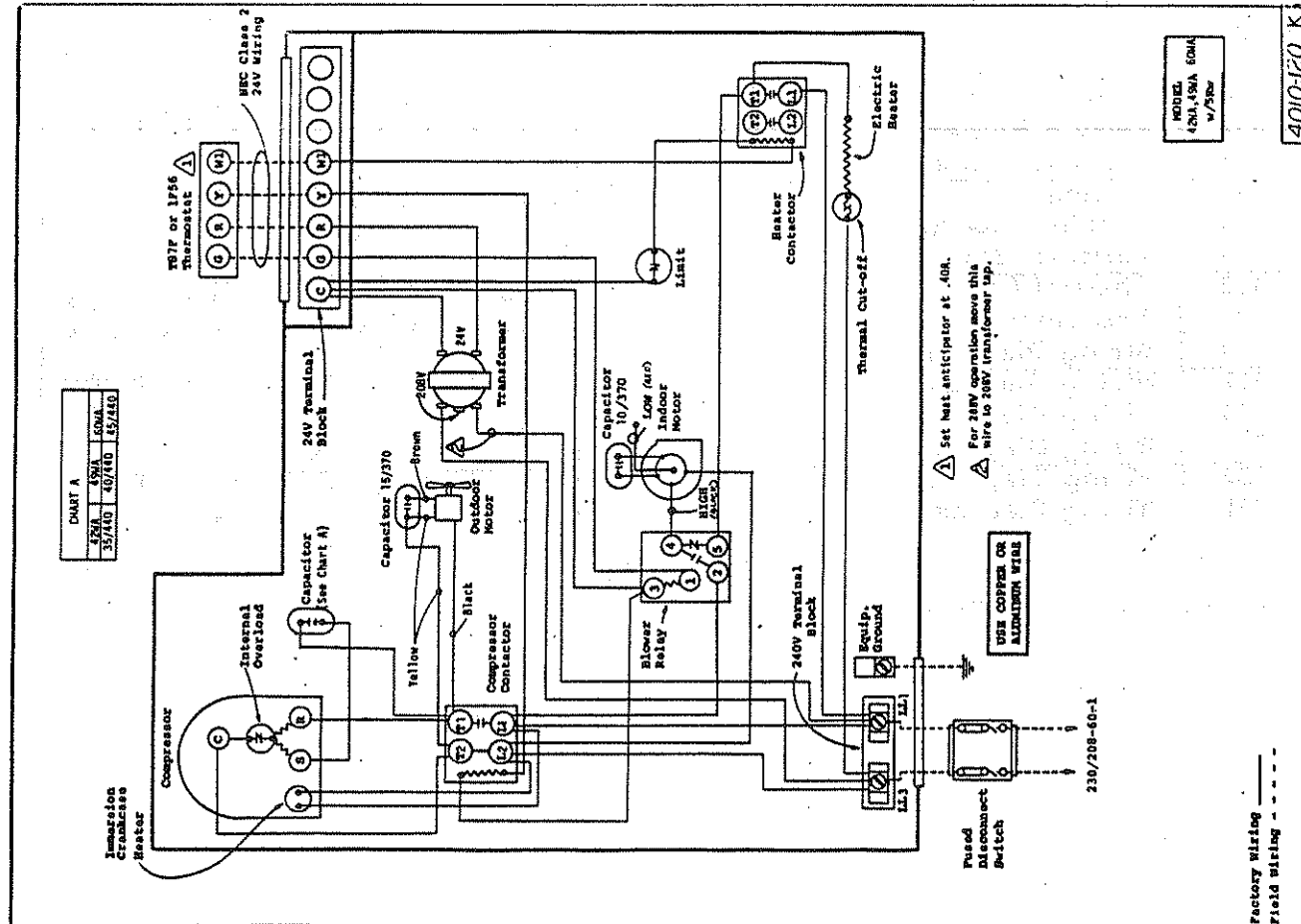

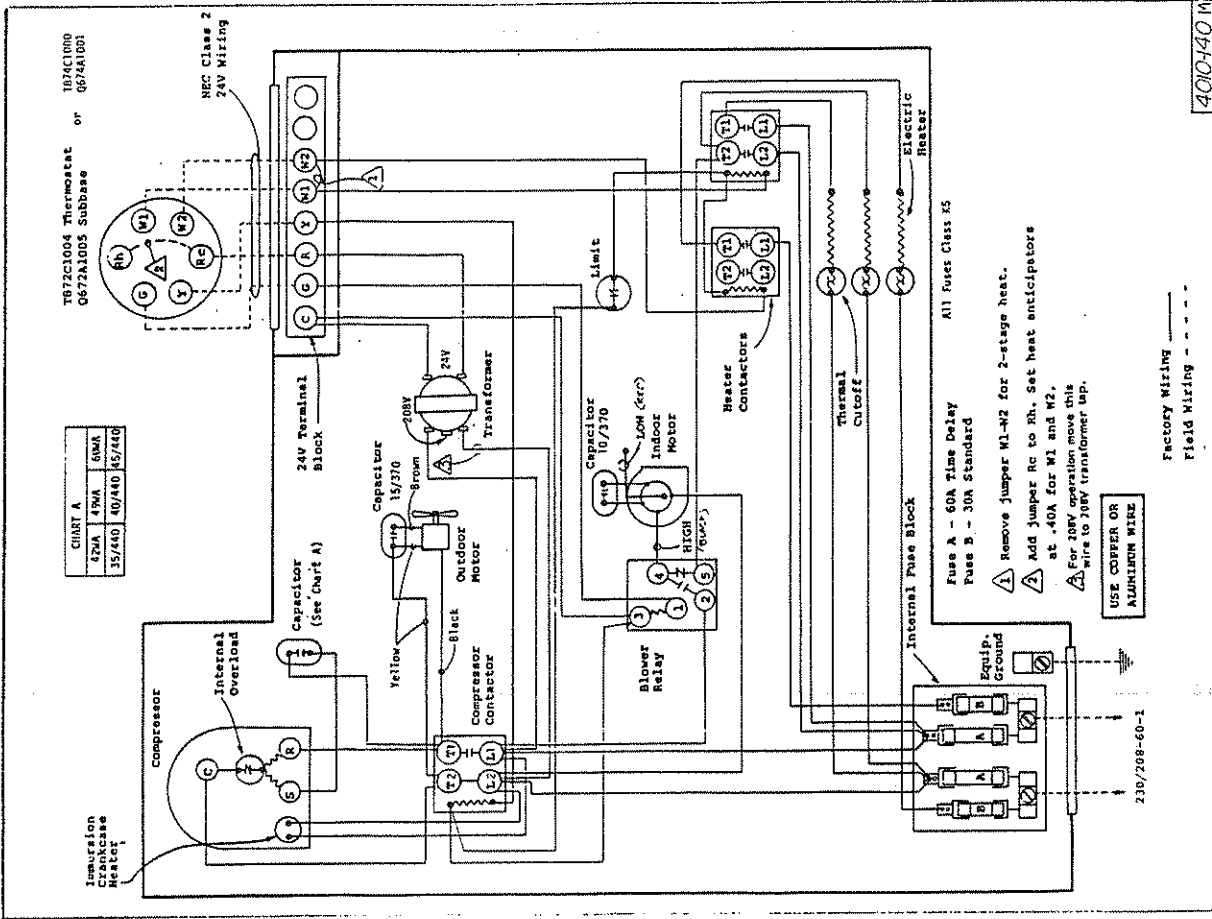
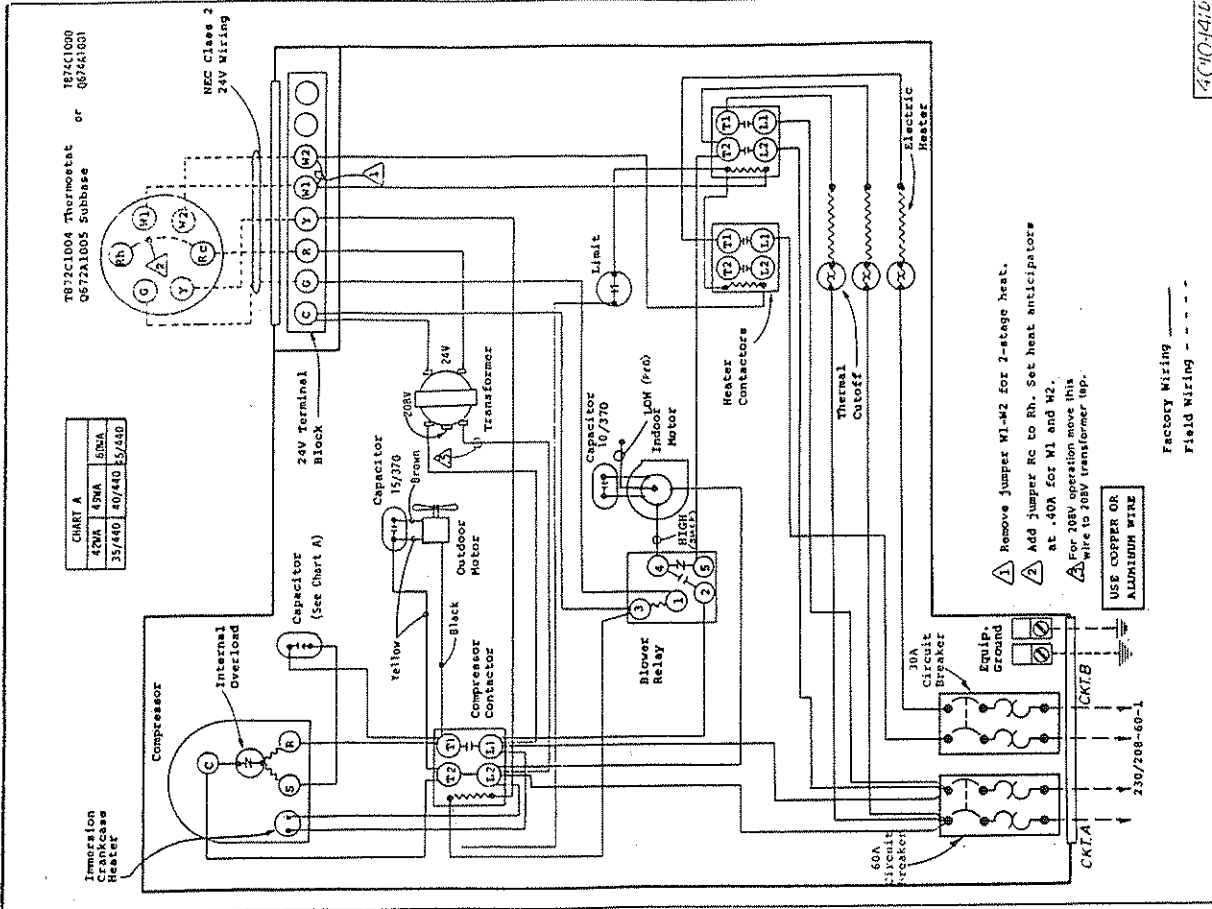

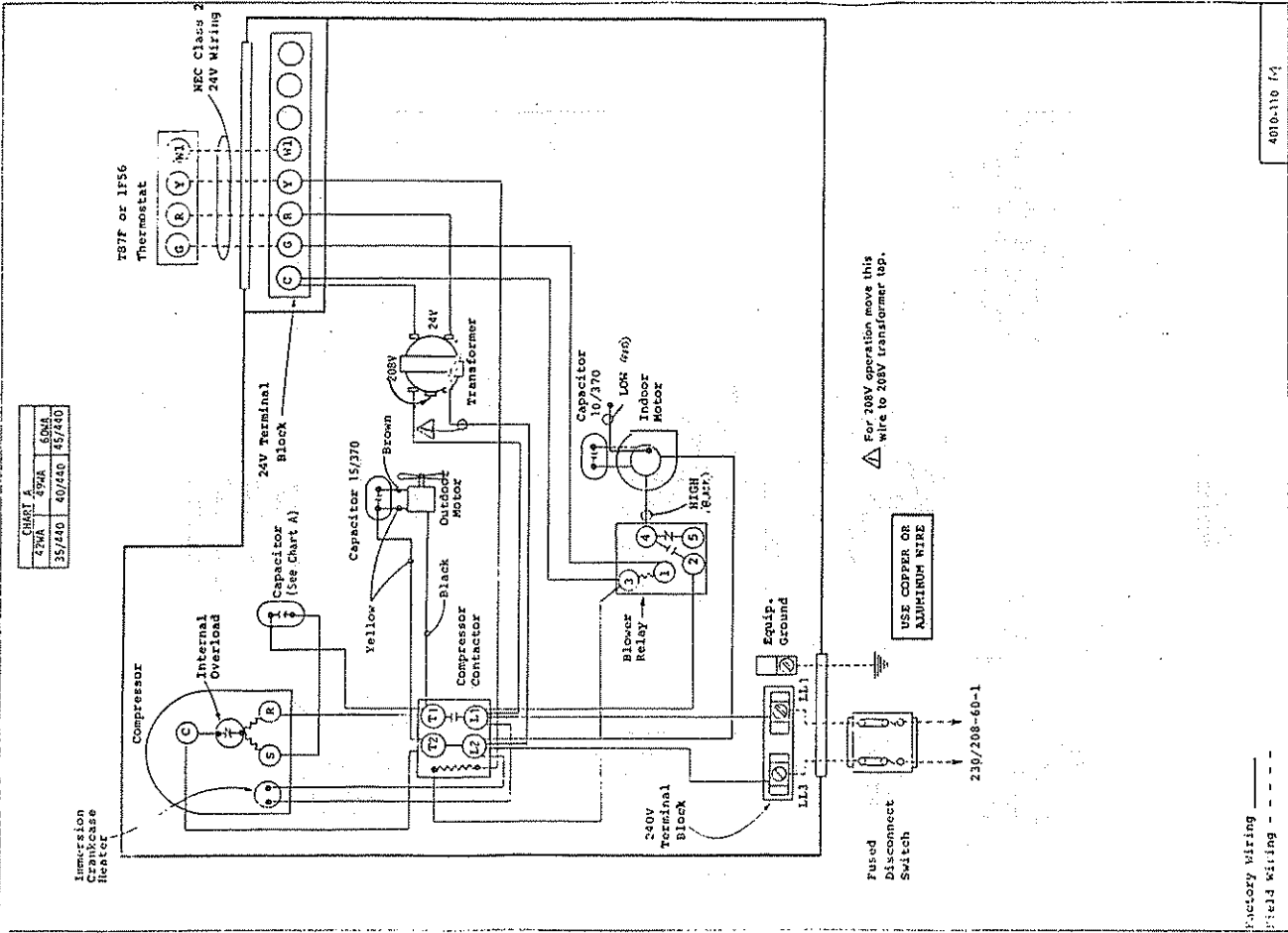

480-110 f4

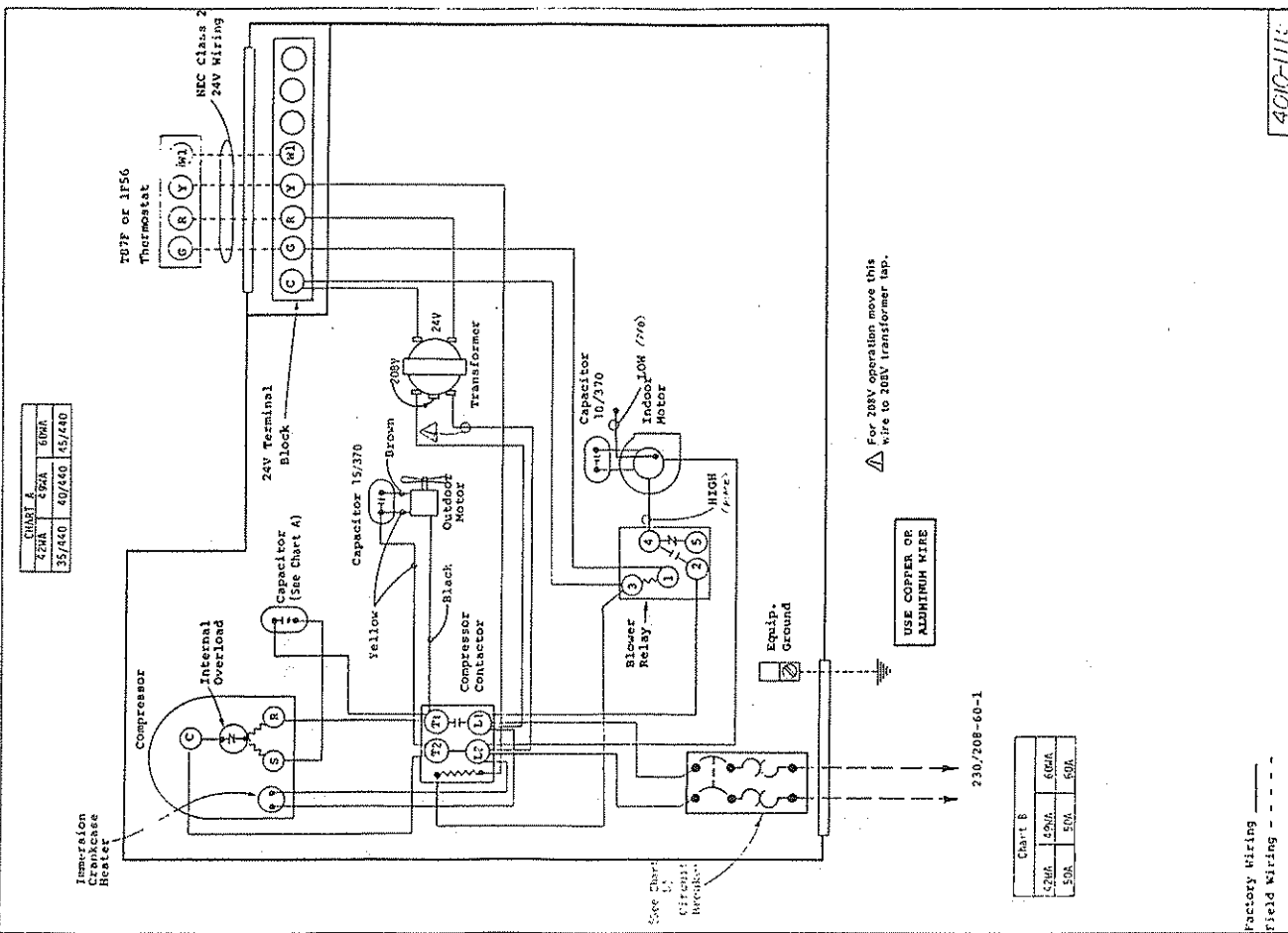

480-111c

CHART A

42MA	45MA	60MA
35/440	40/440	45/440

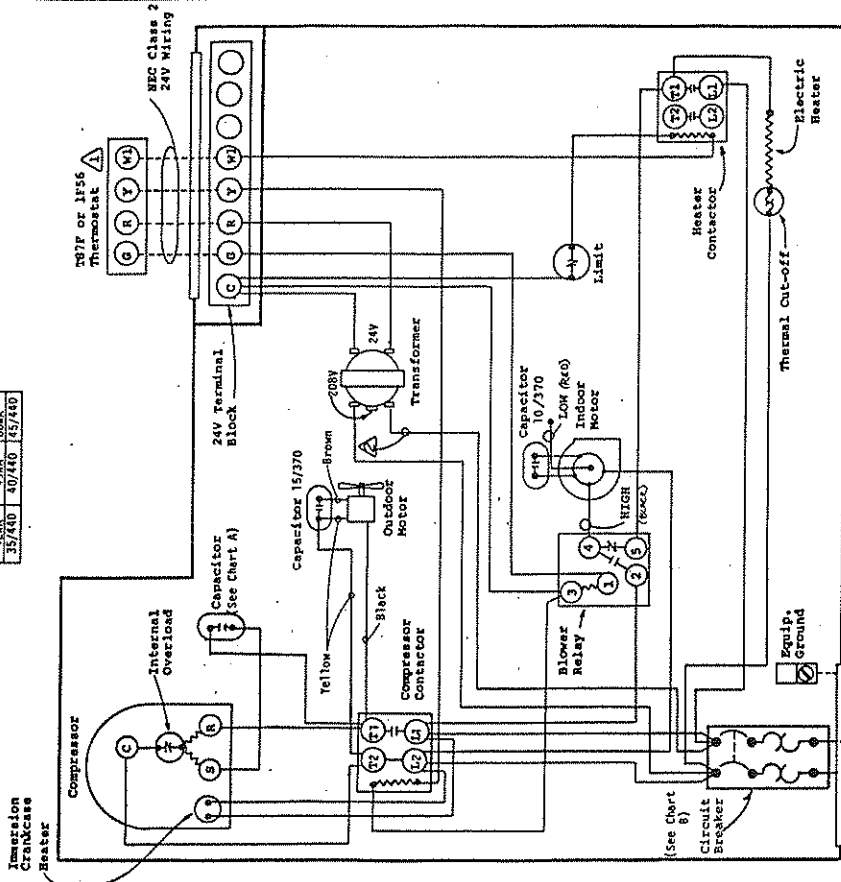

Chart B

42MA	45MA	60MA
50A	50A	50A

MODEL
42MA, 45MA, 60MA
v/3Rv

4010-121C

Factory Wiring
Field Wiring

⚠ Set heat anticipator at .40A.
For 208V operation move this wire to 208V transformer tap.

USE COPPER OR ALUMINUM WIRE

230/208-60-1

CHART A

42MA	45MA	60MA
35/440	40/440	45/440

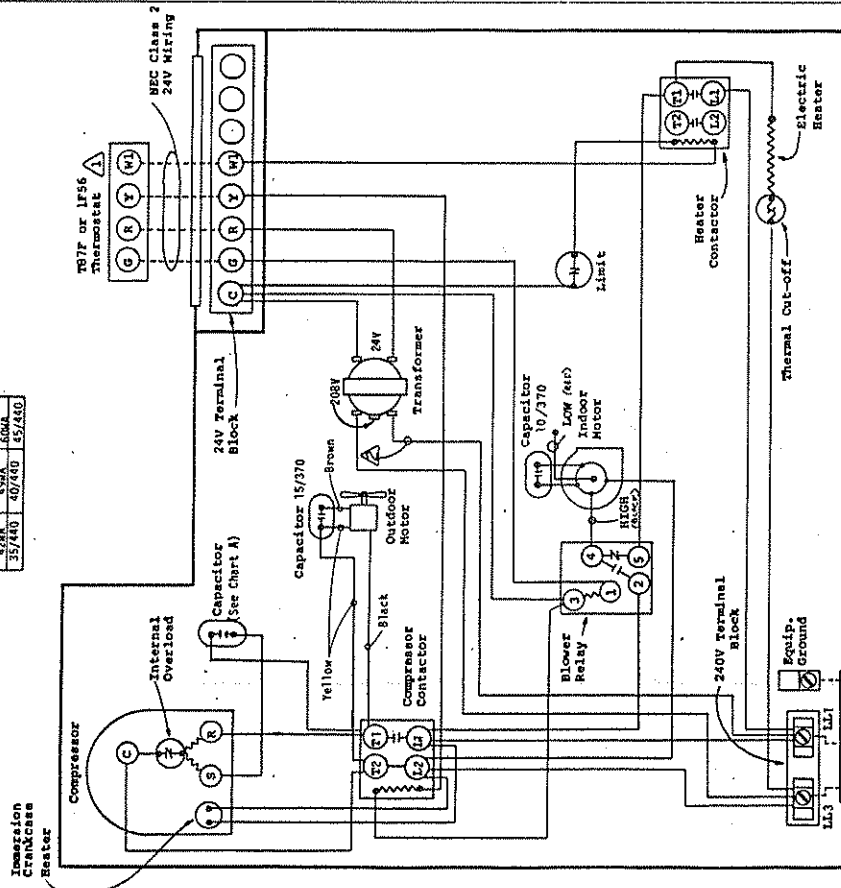

MODEL
42MA, 45MA, 60MA
v/3Rv

4010-120 K

Factory Wiring
Field Wiring

⚠ Set heat anticipator at .40A.
For 208V operation move this wire to 208V transformer tap.

USE COPPER OR ALUMINUM WIRE

230/208-60-1

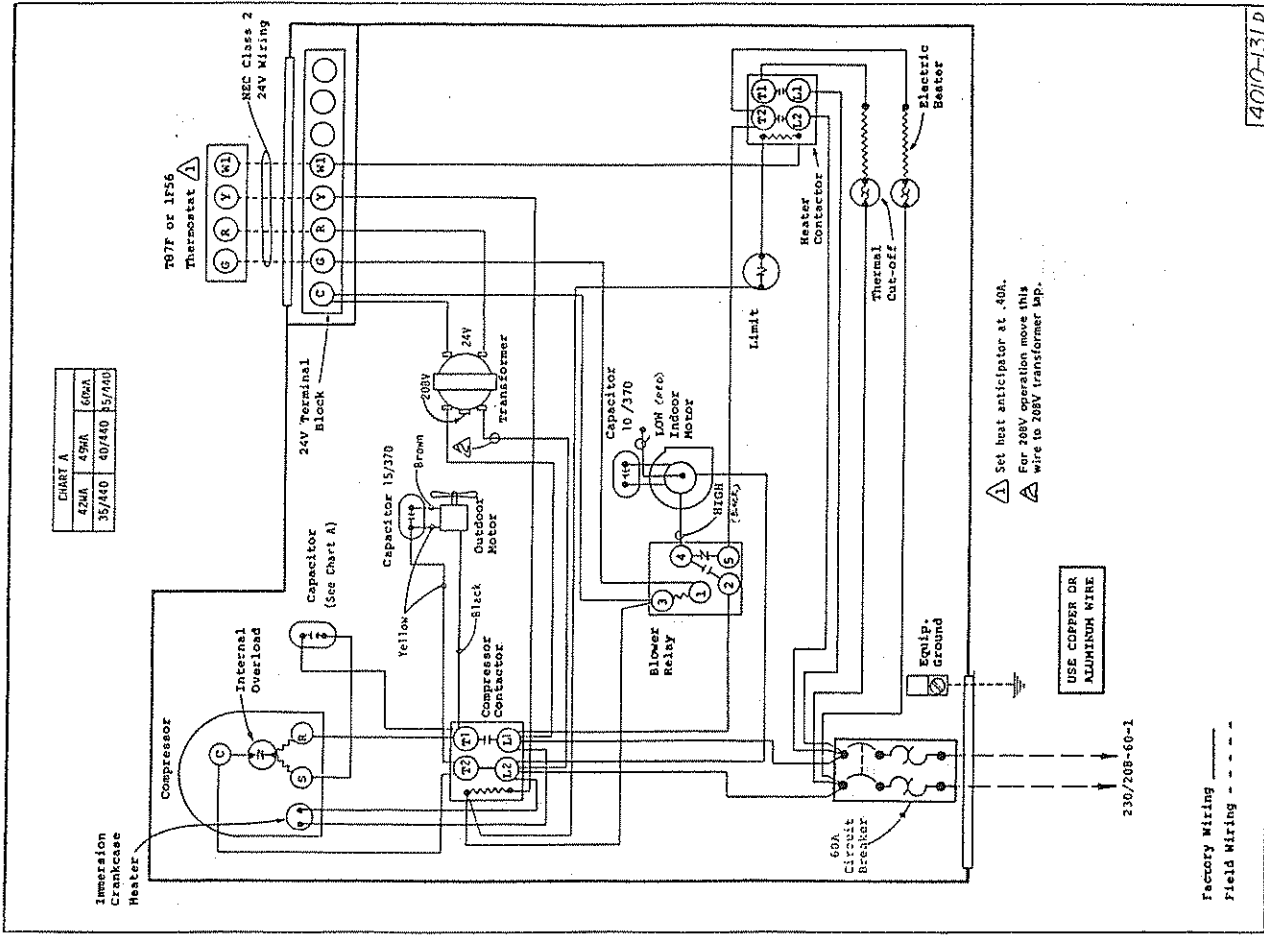
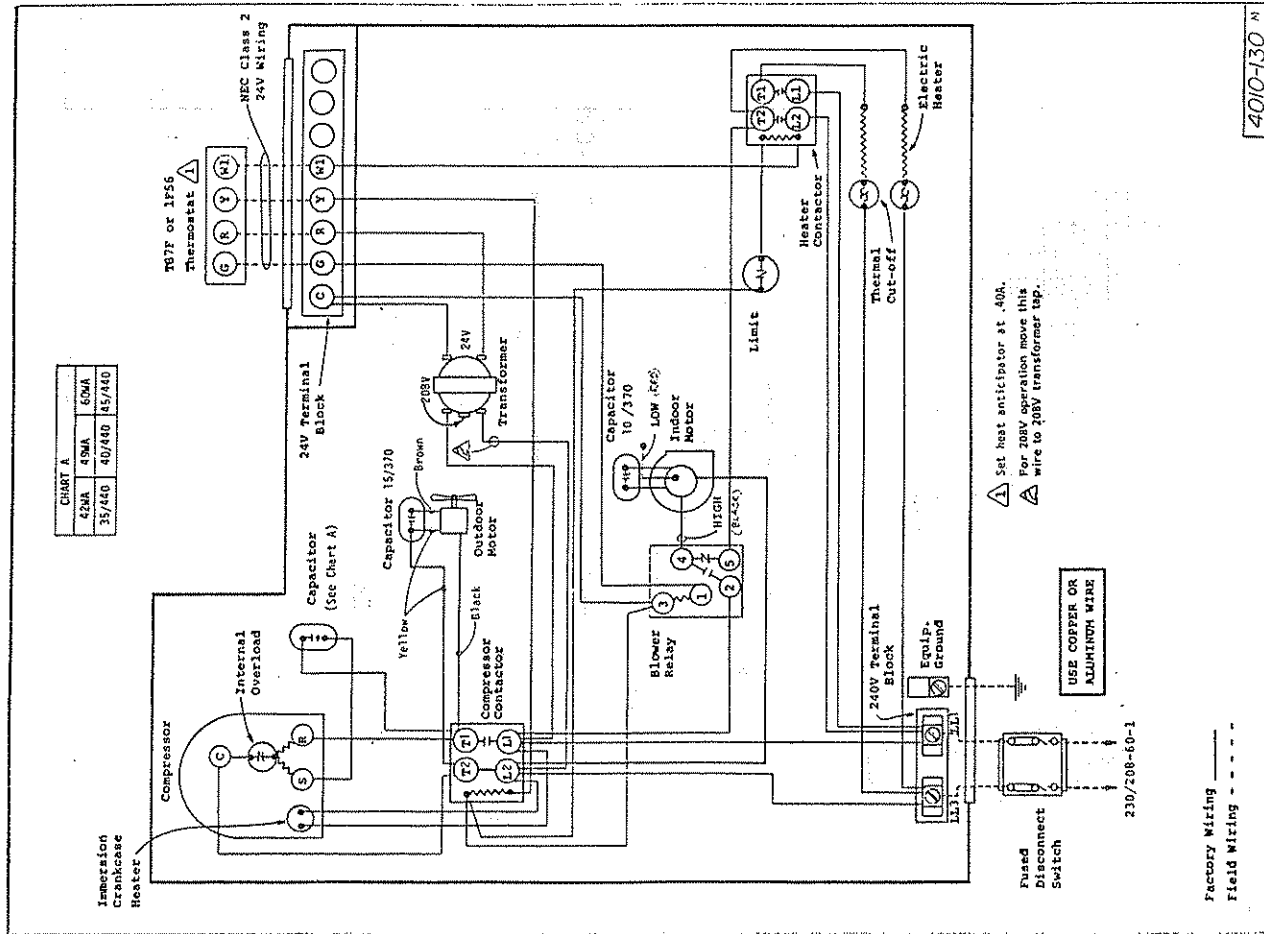

⚠ Set heat anticipator at .40A.
For 208V operation move this wire to 208V transformer tap.

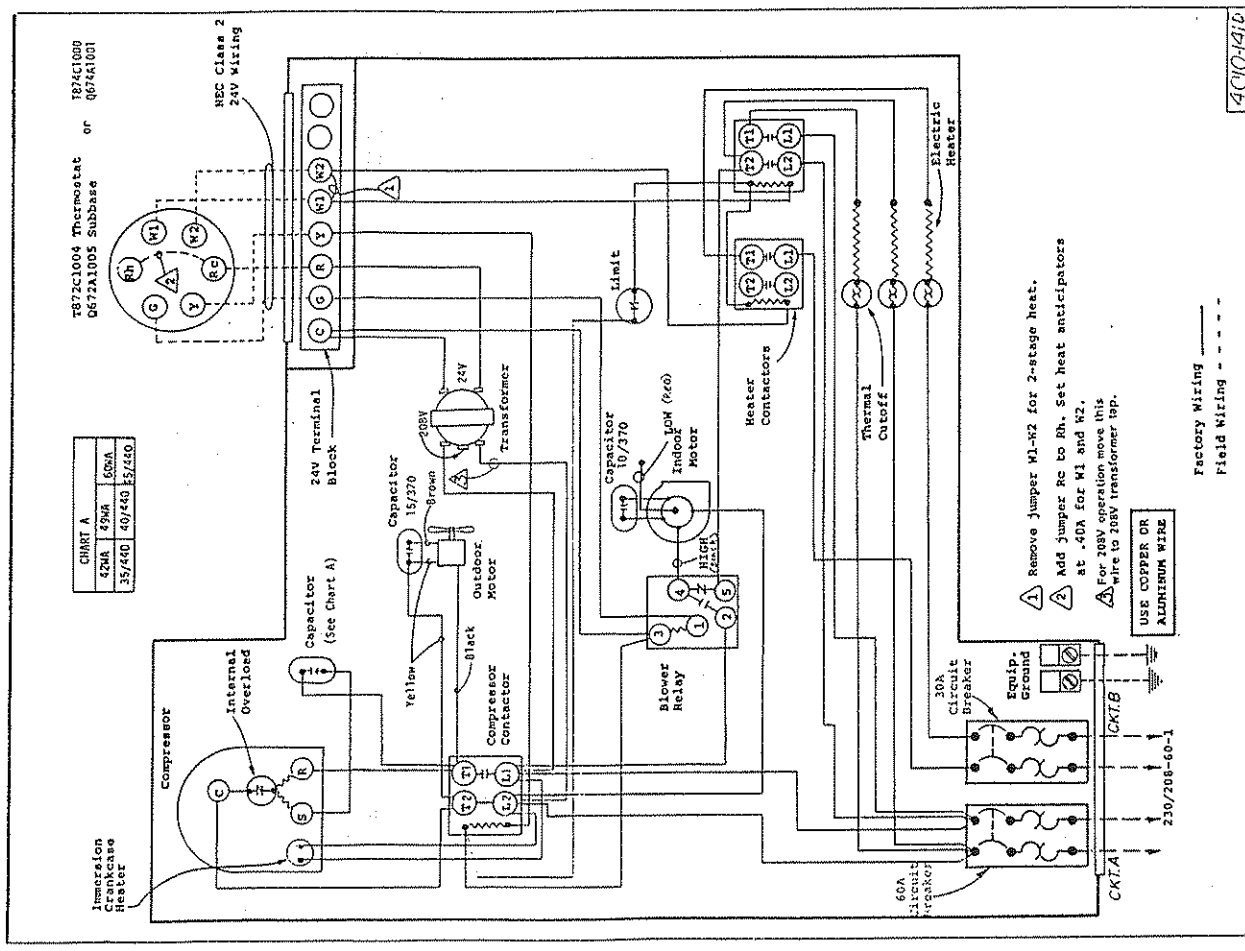
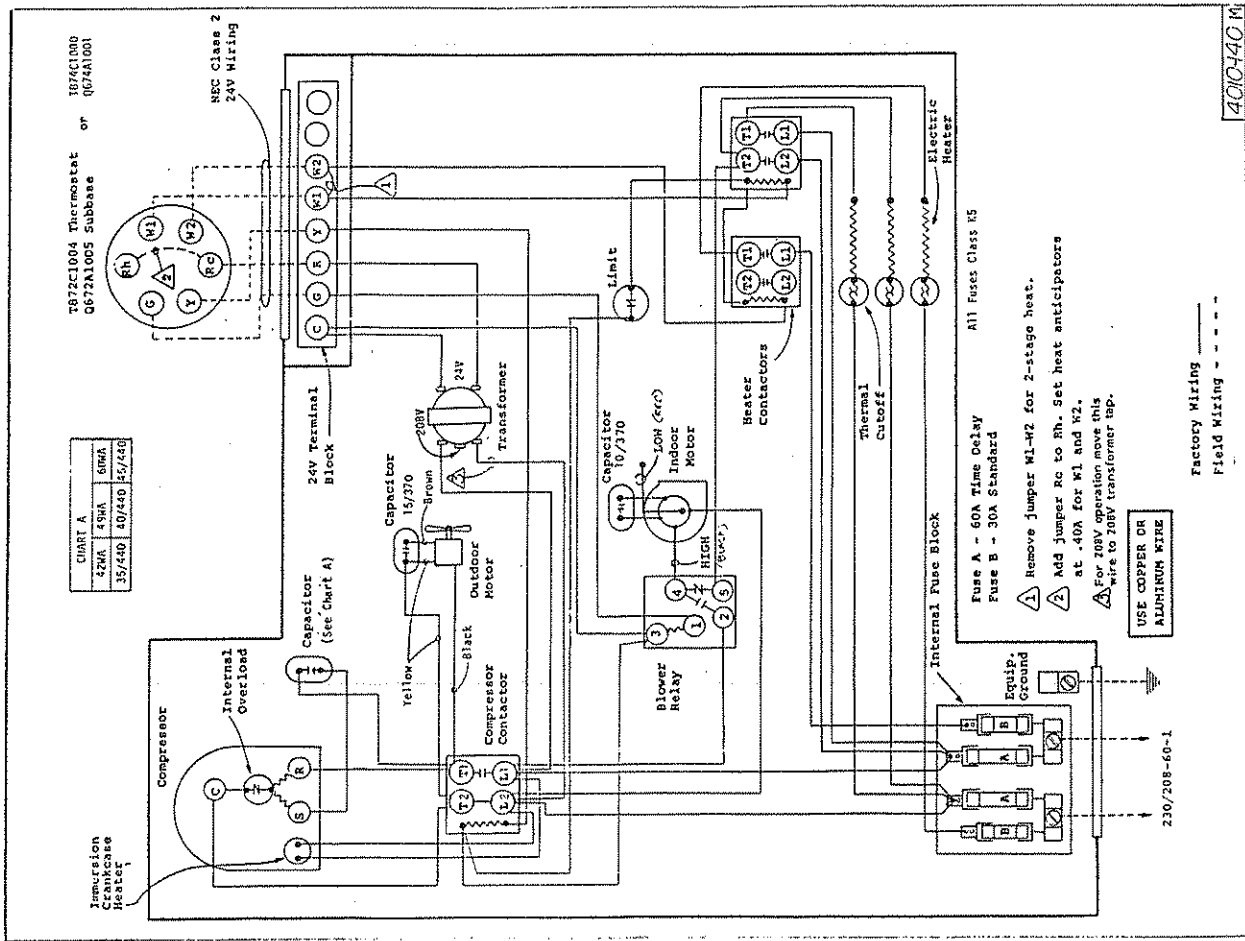
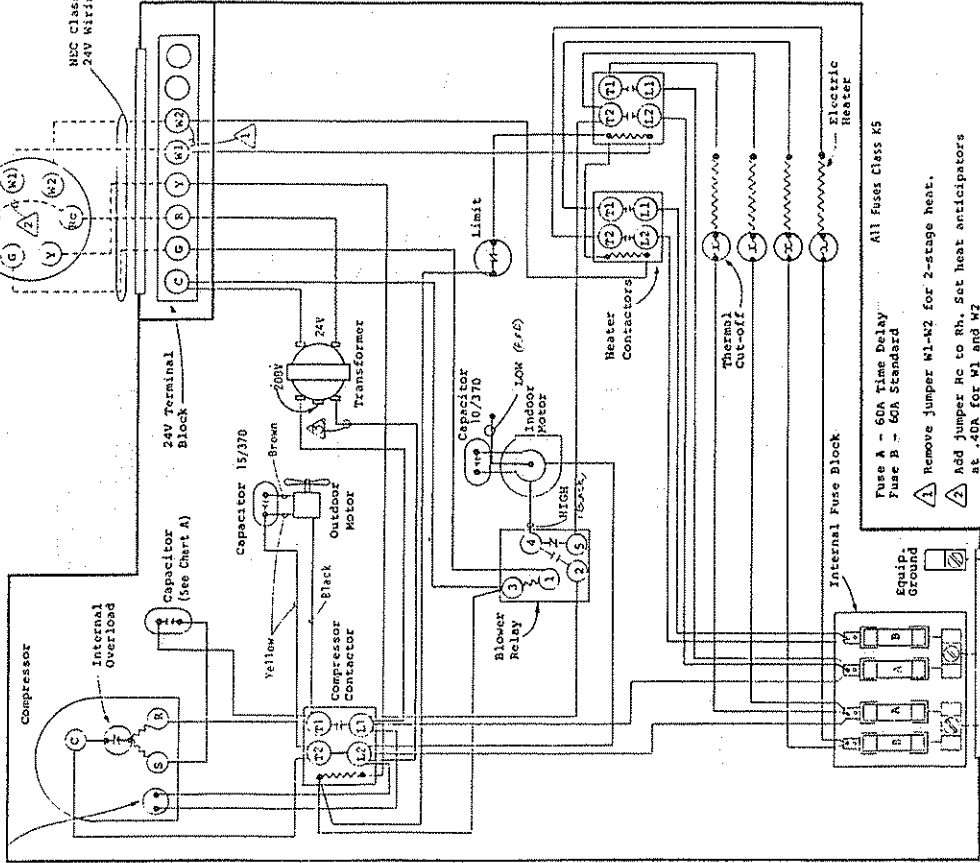

CHART A		
42NA	45NA	62NA
35/440	40/440	45/440

1872C1004 Thermostat or
0672A1005 Subbase

NEC Class 2
24V Wiring

Immersion
Crankcase
Heater



- ▲ Remove Jumper W1-W2 for 2-stage heat.
- ▲ Add jumper Rc to Rh. Set heat anticipators at .40A for W1 and W2
- ▲ For 208V operation move this wire to 208V transformer tap.

USE COPPER OR
ALUMINUM WIRE

230/208-60-1

Factory Wiring ———
Field Wiring - - - - -

4010-150-N

CHART A		
42NA	45NA	62NA
35/440	40/440	45/440

1872C1004 Thermostat or
0672A1005 Subbase

NEC Class 2
24V Wiring

Immersion
Crankcase
Heater

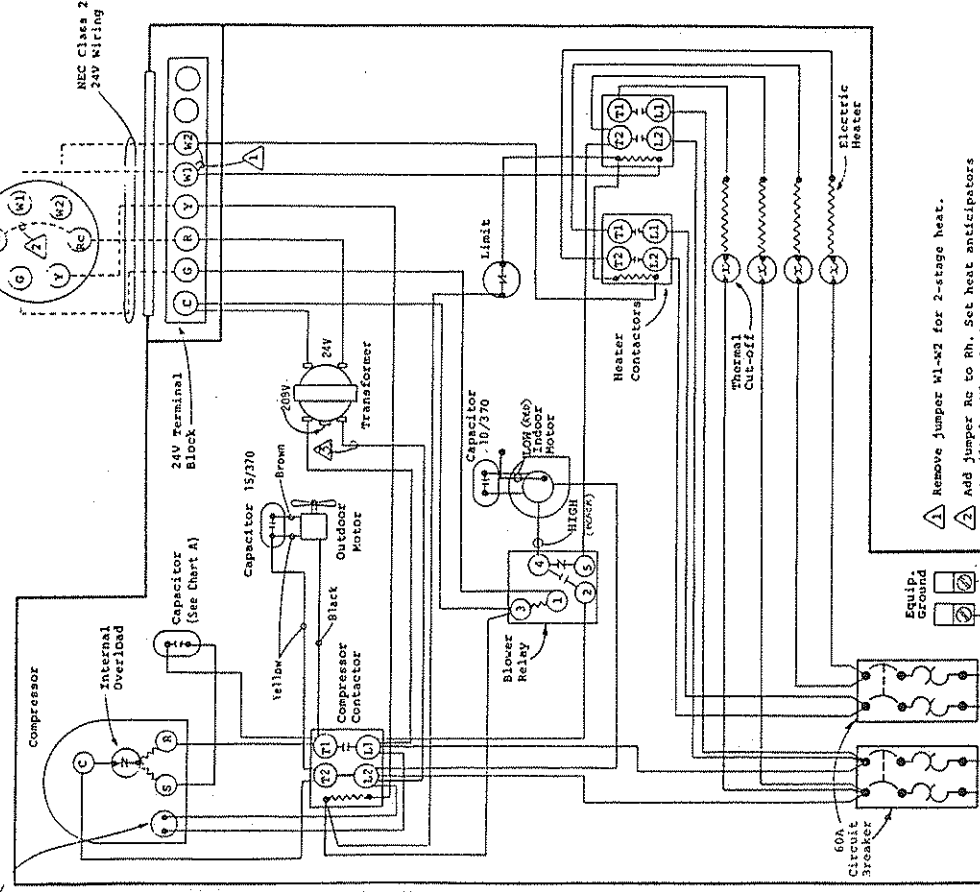

- ▲ Remove Jumper W1-W2 for 2-stage heat.
- ▲ Add jumper Rc to Rh. Set heat anticipators at .40A for W1 and W2
- ▲ For 208V operation move this wire to 208V transformer tap.

USE COPPER OR
ALUMINUM WIRE

230/208-60-1

Factory Wiring ———
Field Wiring - - - - -

4010-151-D

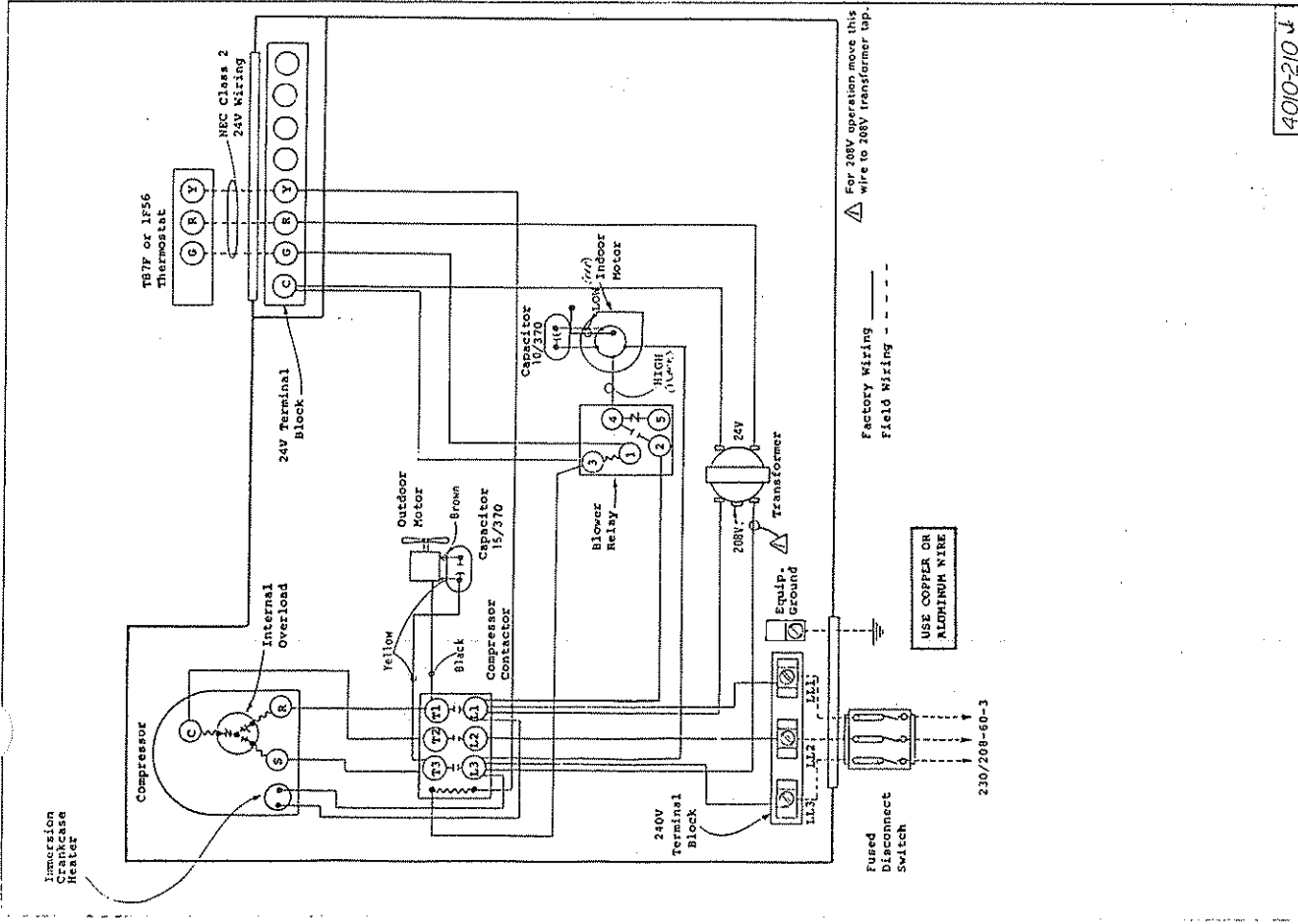
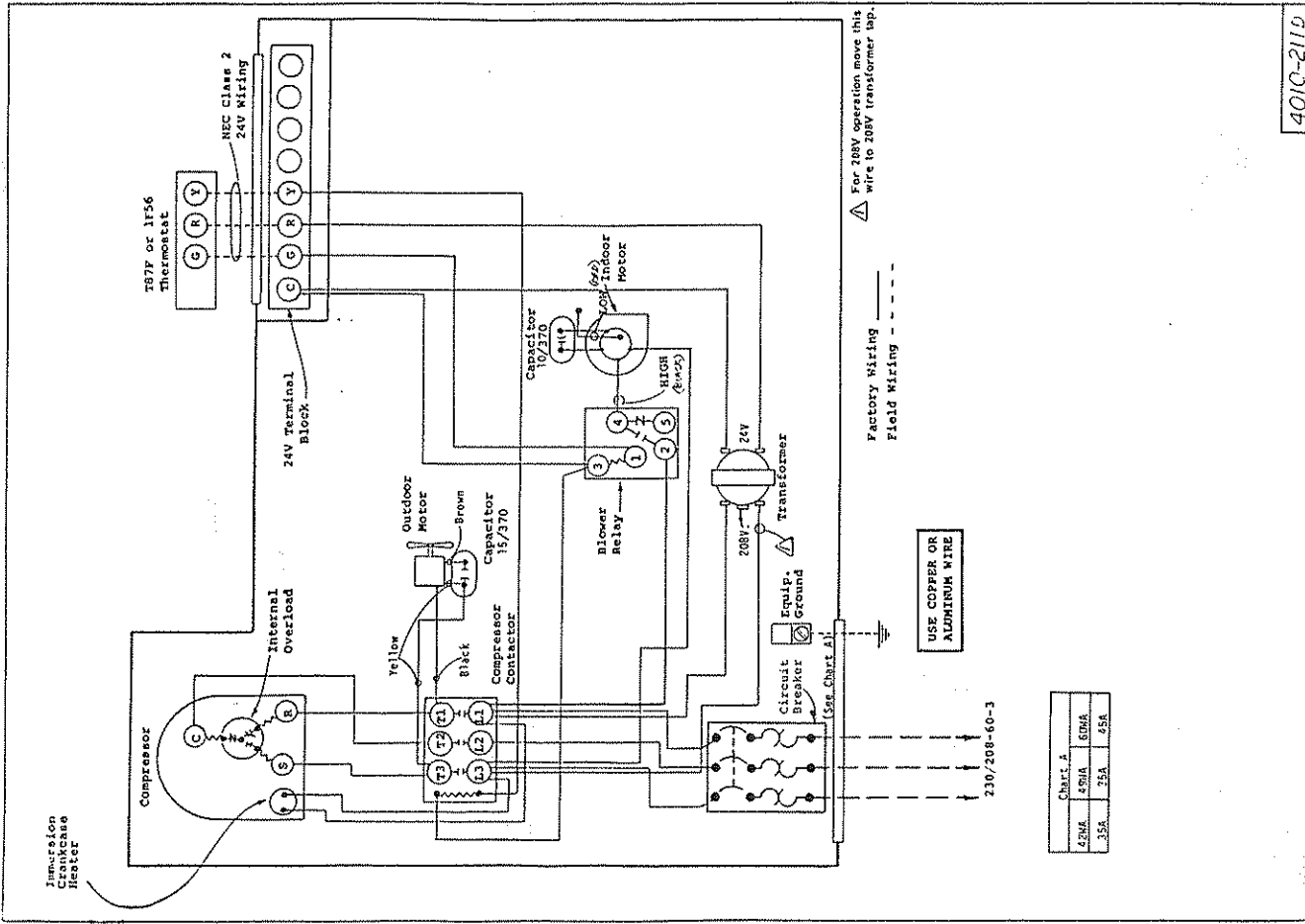

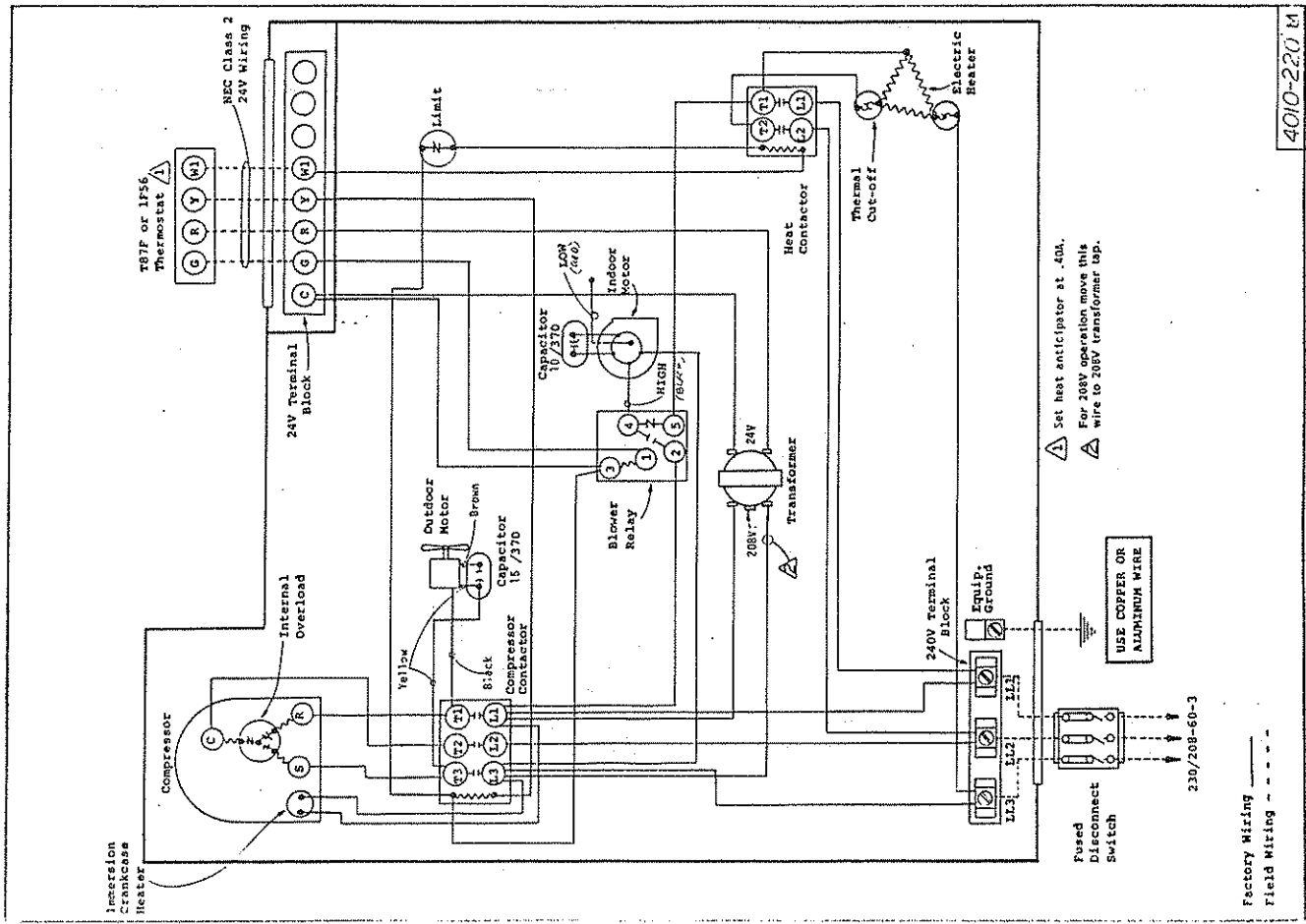

4010-220 M

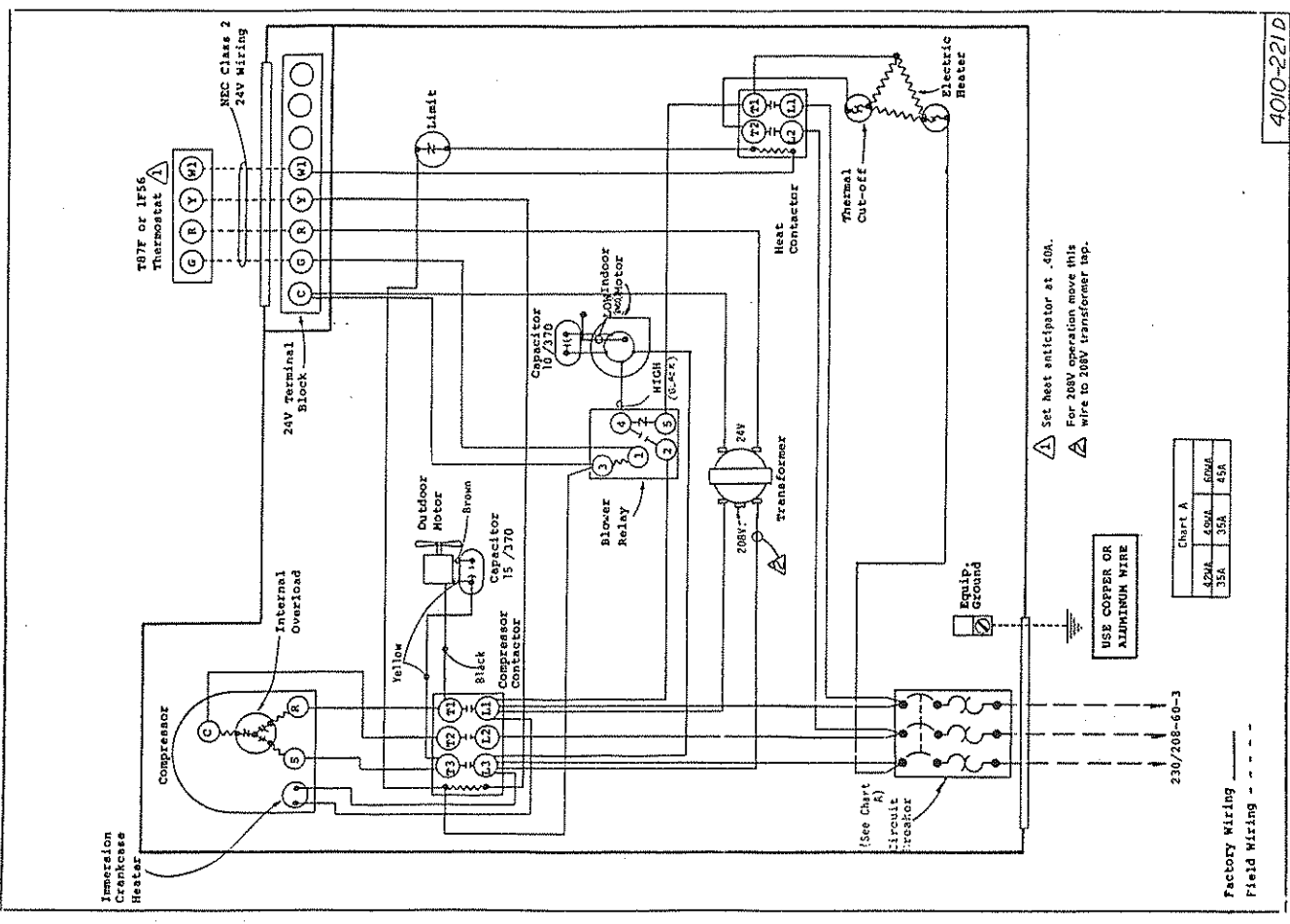

4010-221 D

7B72C1004 Thermostat or
0572A1005 Subbase A

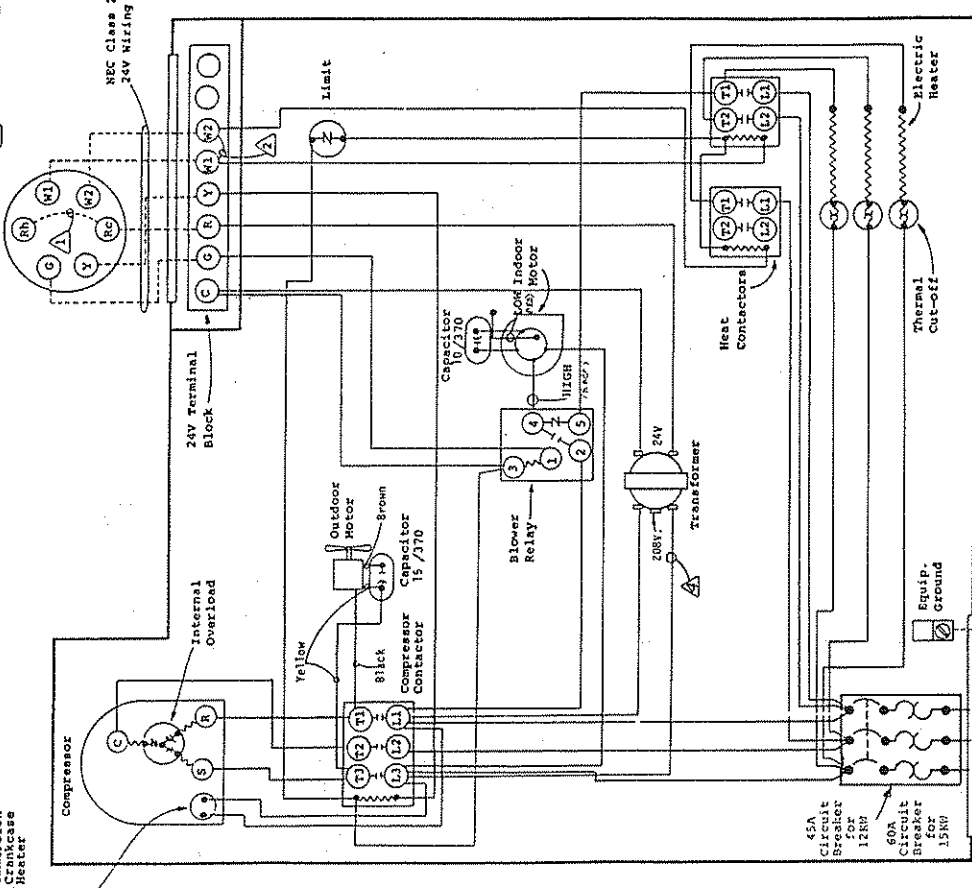

- ▲ Add jumper Rc to Rh. Set heat anticipators at .40A.
- ▲ Remove jumper for 2-stage heat.
- ▲ Set heat anticipator for W1 and W2 at .40A.
- ▲ For 208V operation move this wire to 208V transformer tap.

USE COPPER OR ALUMINUM WIRE

Factory Wiring
Field Wiring

230/708-60-3

7B72C1004 Thermostat or
0572A1005 Subbase A

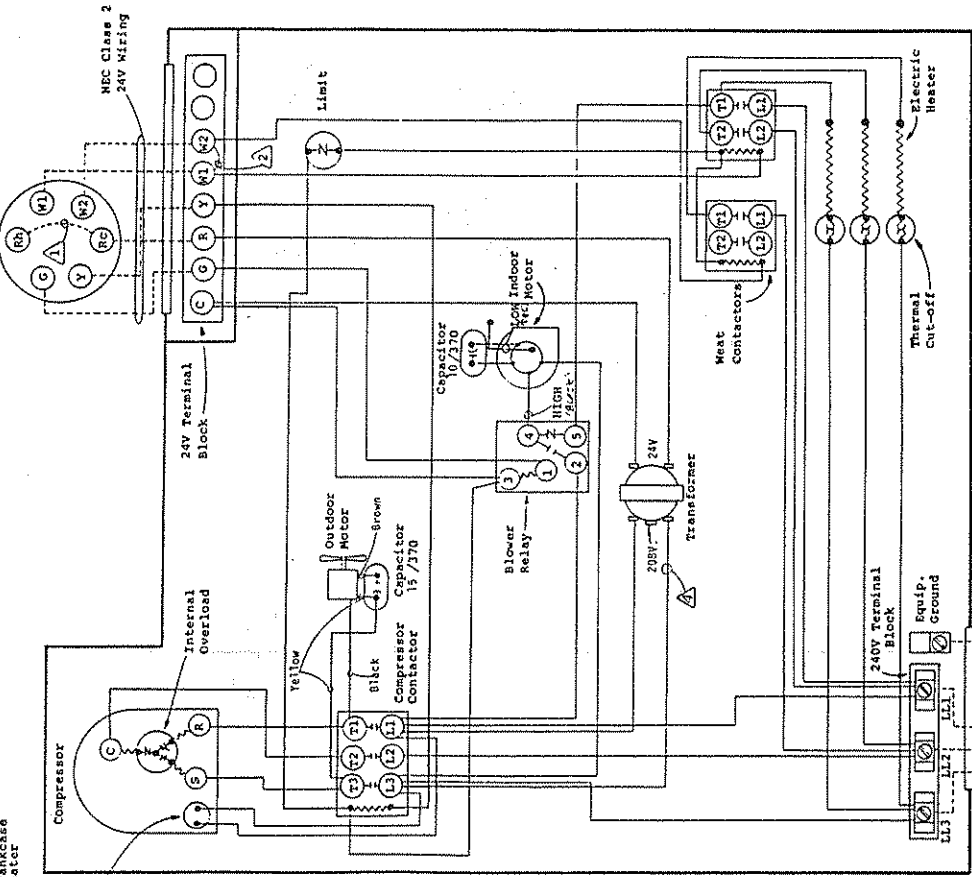

- ▲ Add jumper Rc to Rh. Set heat anticipators at .40A.
- ▲ Remove jumper for 2-stage heat.
- ▲ Set heat anticipator for W1 and W2 at .40A.
- ▲ For 208V operation move this wire to 208V transformer tap.

USE COPPER OR ALUMINUM WIRE

Factory Wiring
Field Wiring

230/208-60-3

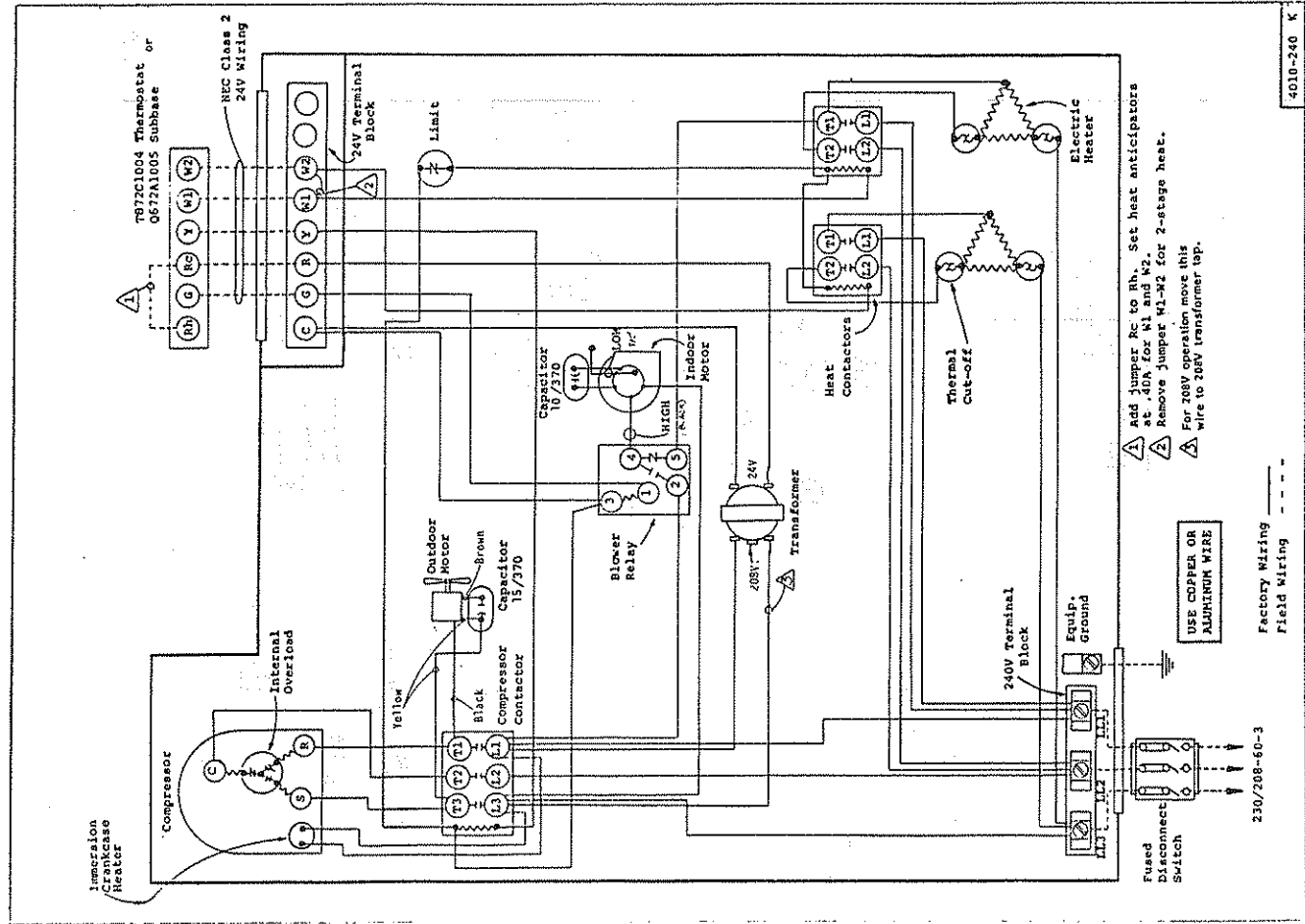

4010-240 K

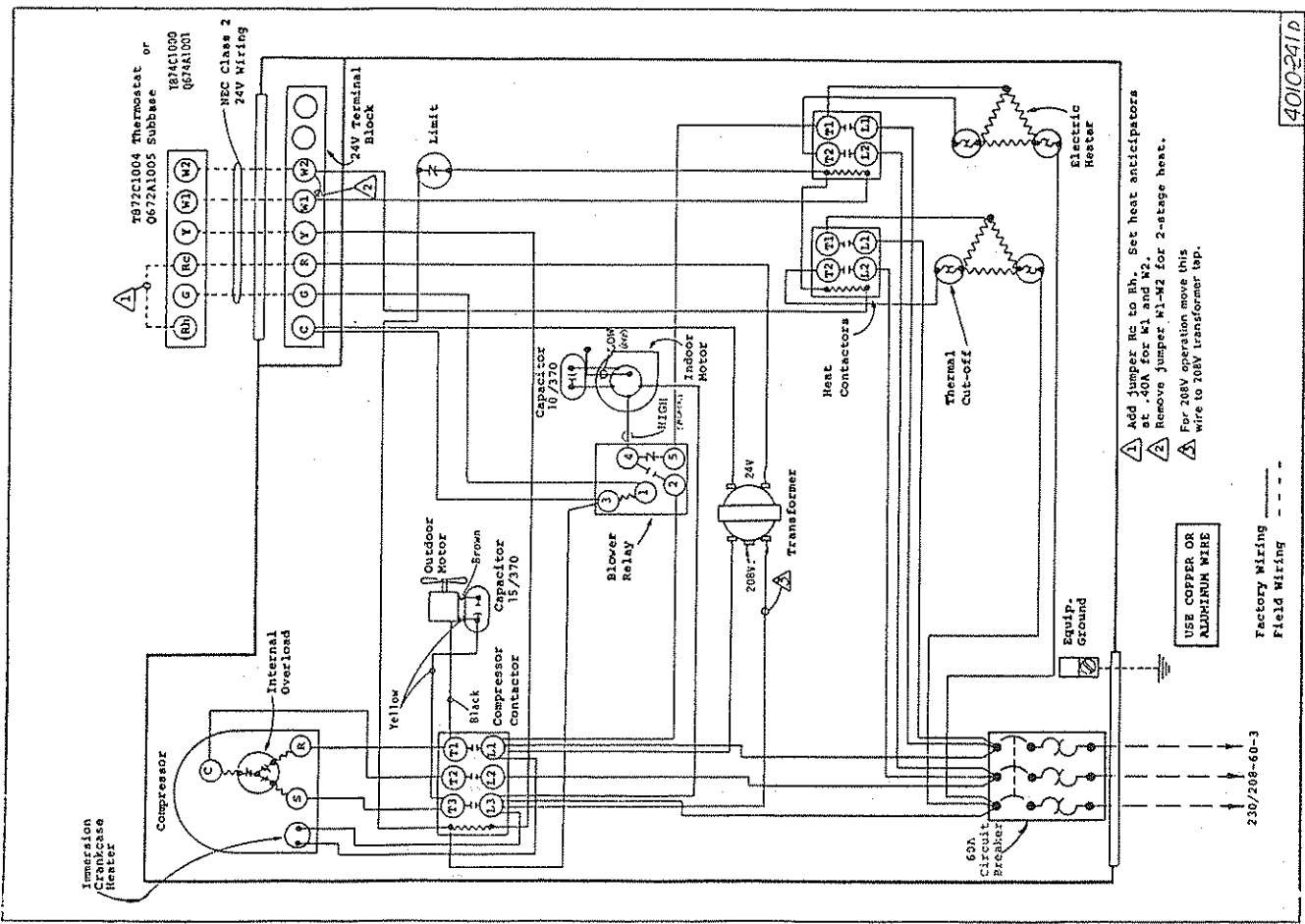

4010-241 D

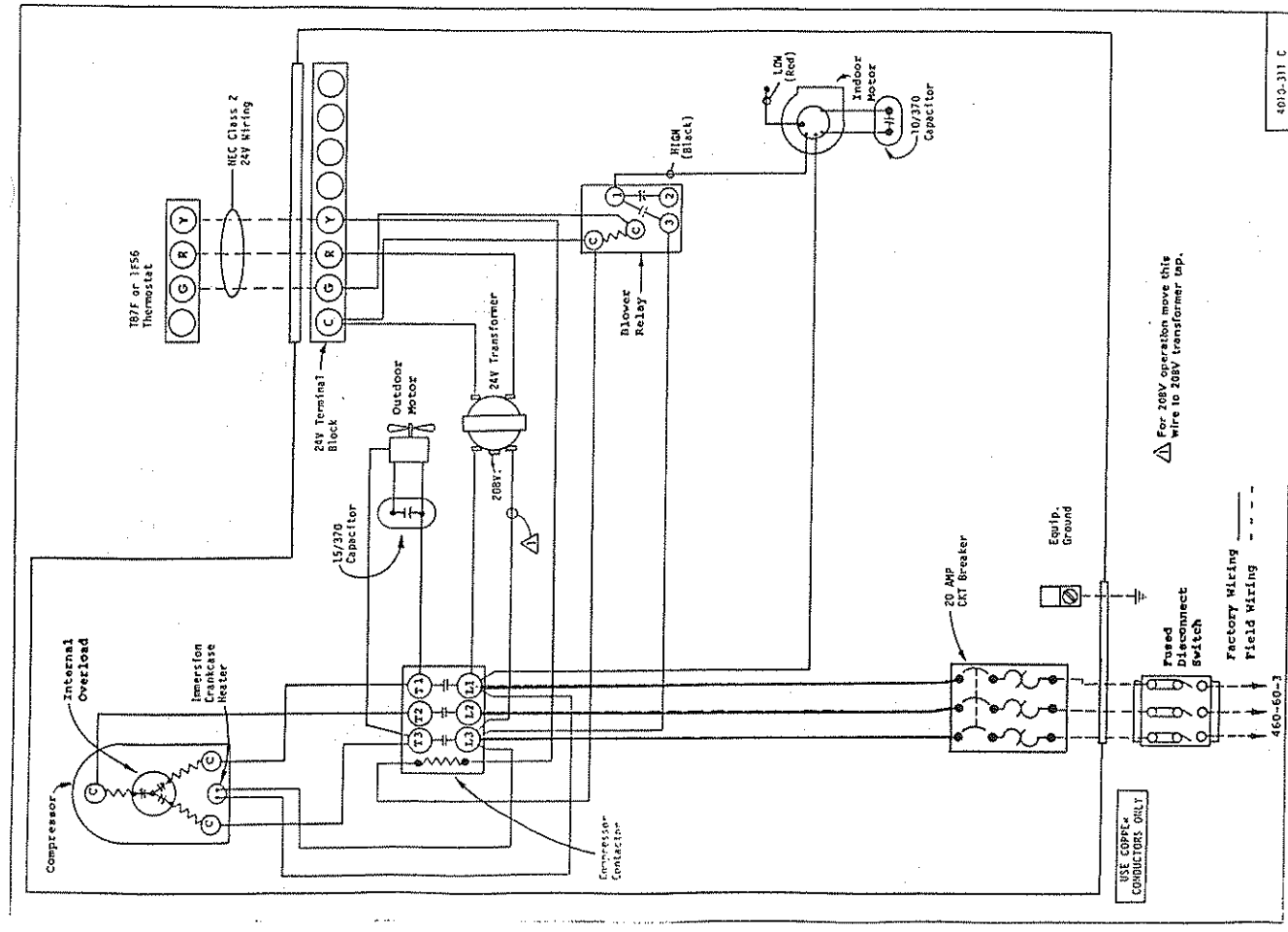
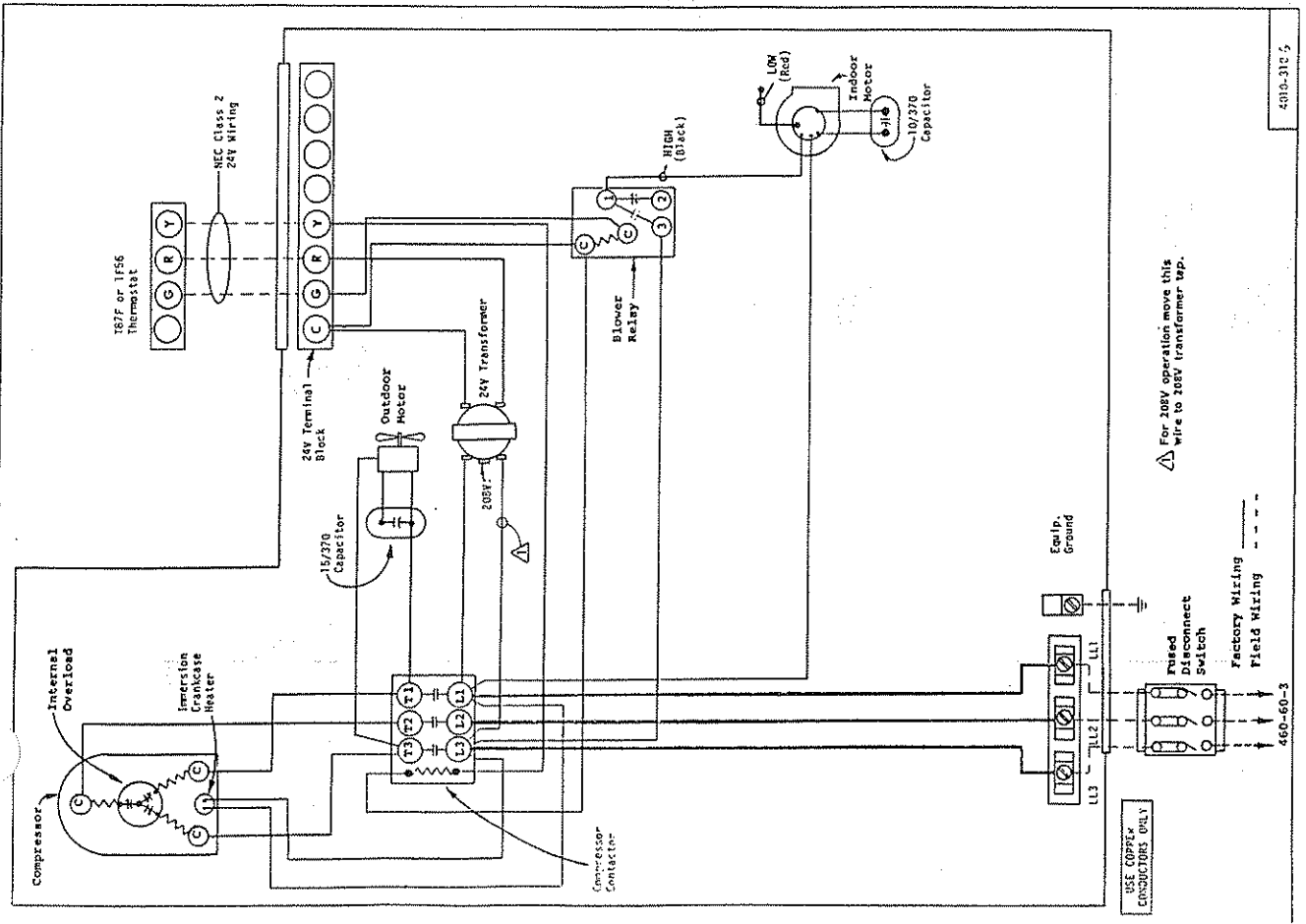

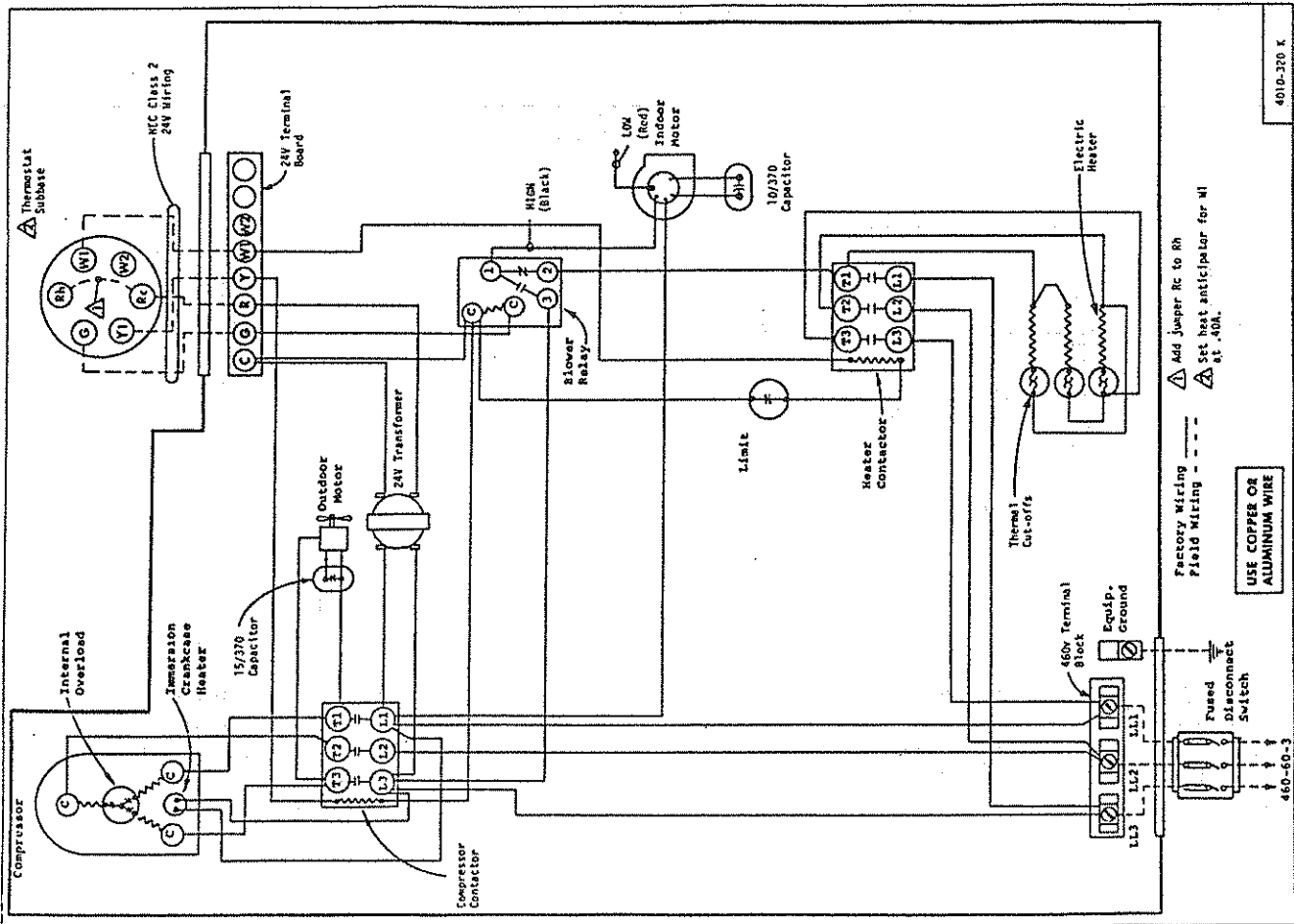
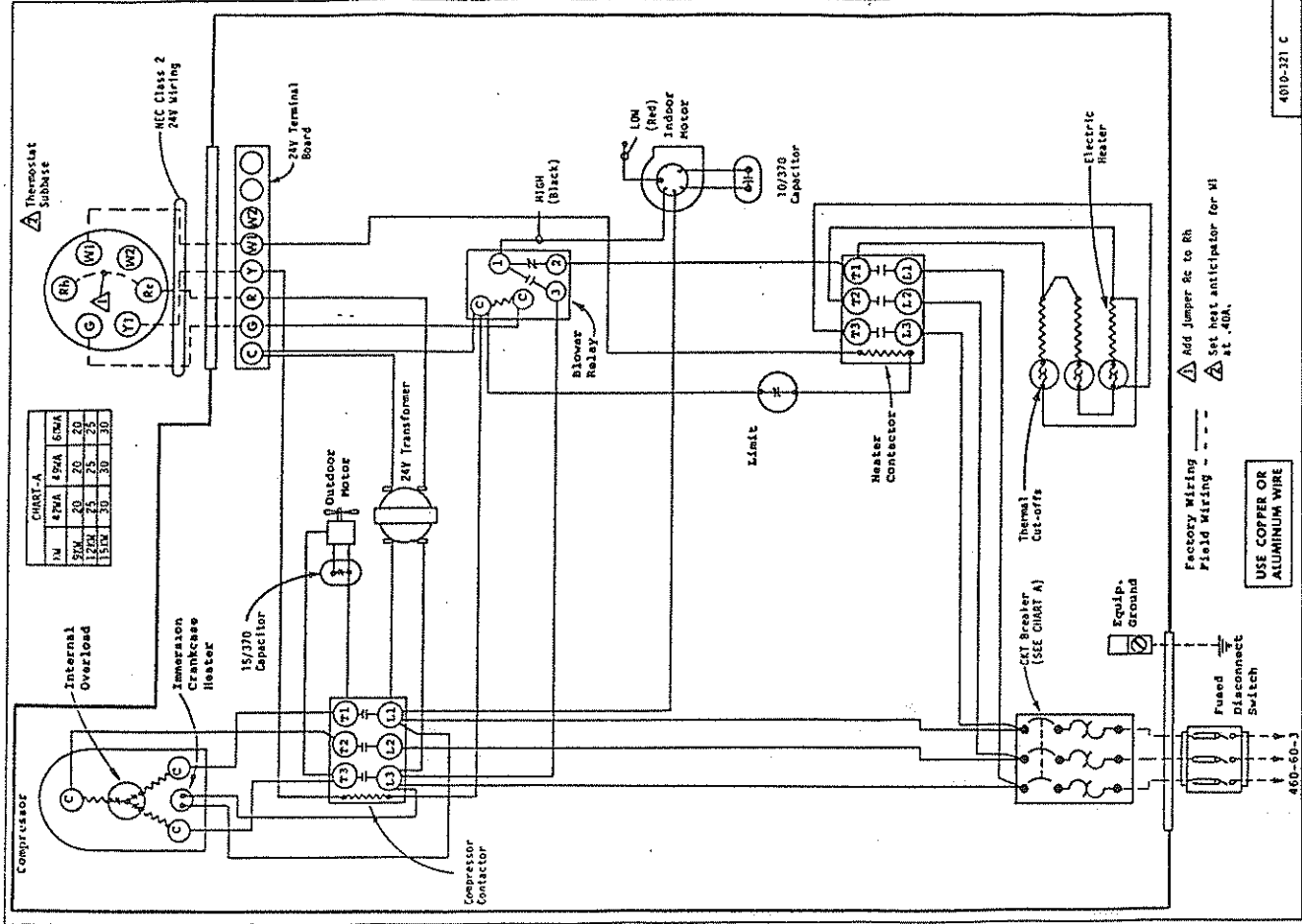

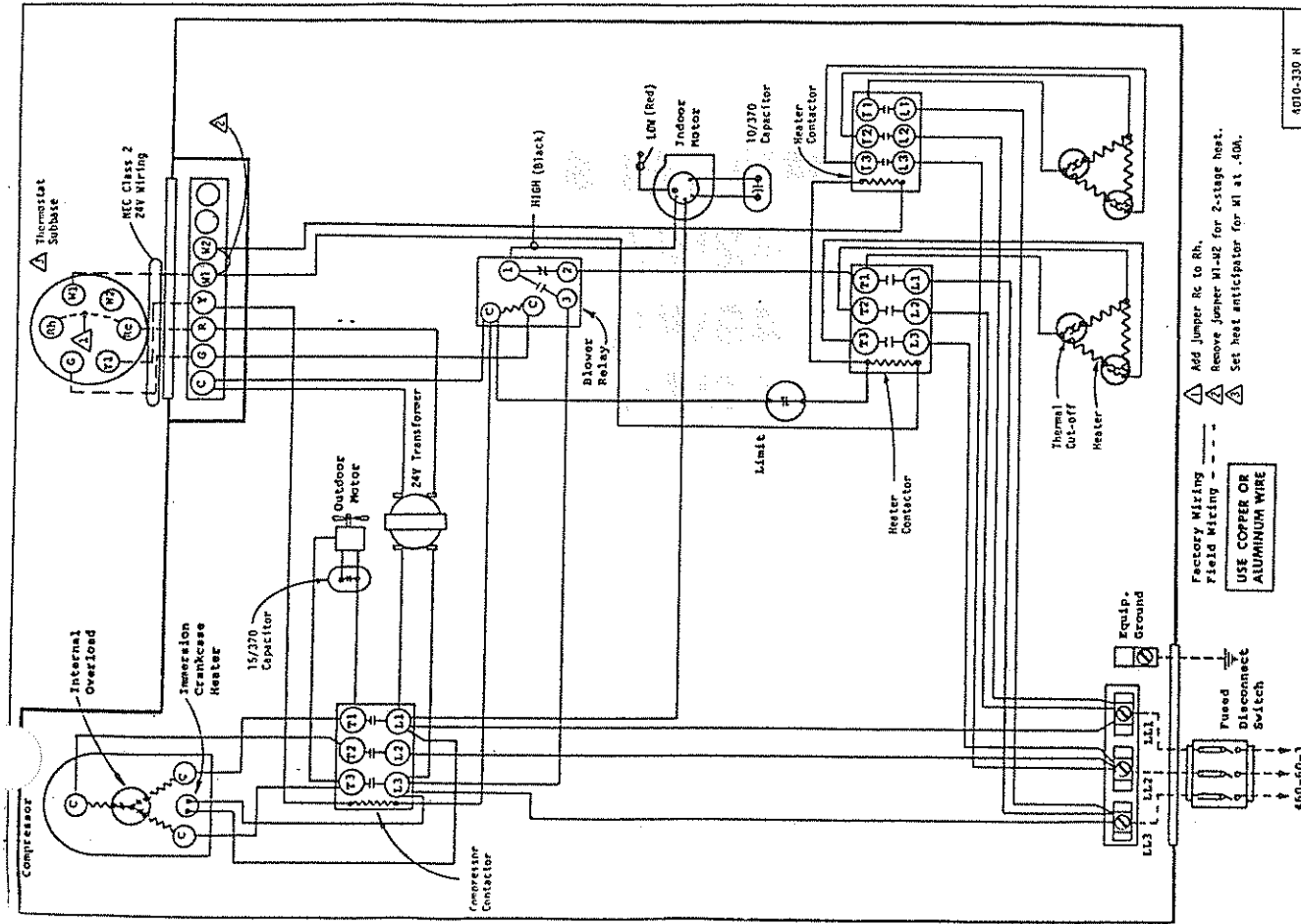
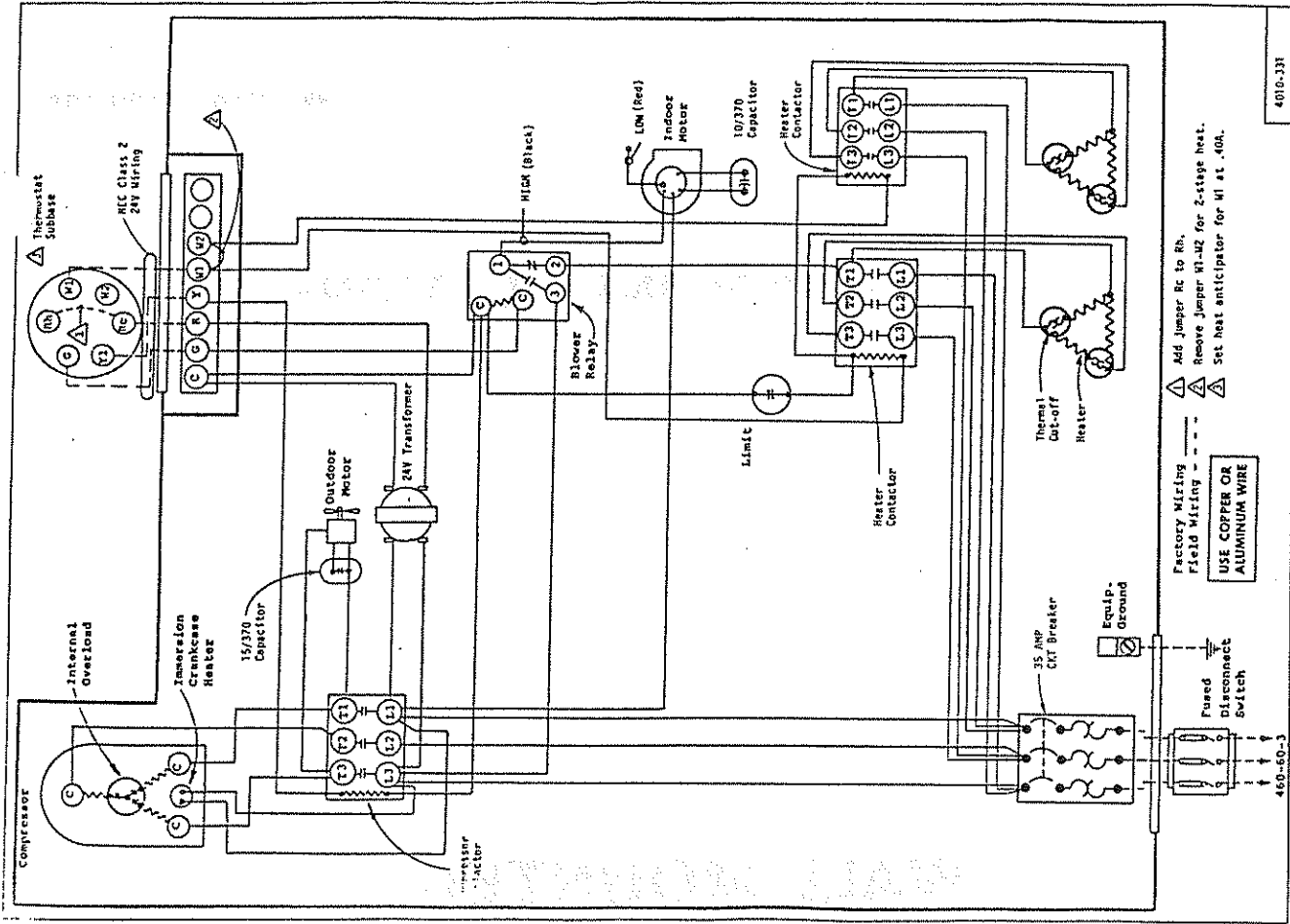

▲ Add Jumper Rc to Rh.
 ▲ Remove Jumper W1-W2 for 2-stage heat.
 ▲ Set heat anticipator for W1 at .40A.
 Factory Wiring - - -
 Field Wiring - - -
USE COPPER OR ALUMINUM WIRE

▲ Add Jumper Rc to Rh.
 ▲ Remove Jumper W1-W2 for 2-stage heat.
 ▲ Set heat anticipator for W1 at .40A.
 Factory Wiring - - -
 Field Wiring - - -
USE COPPER OR ALUMINUM WIRE

INSTALLATION INSTRUCTIONS

**WALL MOUNTED
PACKAGE AIR CONDITIONERS**

MODELS

42WA

49WA

60WA

ELECTRICAL INFORMATION										WIRING INFORMATION**	
Model	Rated Volts/Ph	Operating Voltage Range	Heater* KW	Max Unit Amps	No. Field Power Circuits	Internal Fuses		Required ^① Overcurrent Protection	Minimum Circuit Ampacity	Field Power Wiring	Ground Wire Size
						Ckt. A	Ckt. B	Ckt. A	Ckt. A	Ckt. A	Ckt. A
42WA	230/208-1	197-253	0	27.3	1			50	33	8	10
			5	27.3	1			50	33	8	10
			10	45.6	1			60	57	4	10
			15	66.5	1	60	30	90	84	3	8
			20	87.2	1	60	60	110	109	1	6
42WA-B	230/208-3	187-253	0	19.8	1			35	24	10	10
			9	25.7	1			35	33	8	10
			12	32.9	1			45	41	6	10
			15	40.2	1			60	51	6	10
			18	47.4	1			60	60	4	10
42WA-C	460-3	414-506	0	11.4	1			20	15	14	14
			9	12.8	1			20	16	12	12
			12	16.2	1			25	21	10	10
			15	20	1			30	25	10	10
			18	23.7	1			35	30	8	10
49WA	230/208-1	197-253	0	28.8	1			50	35	8	10
			5	28.8	1			50	35	8	10
			10	45.6	1			60	57	4	10
			15	66.5	1	60	30	90	84	3	8
			20	87.2	1	60	60	110	109	1	6
49WA-B	230/208-3	187-253	0	20.8	1			35	25	10	10
			9	25.7	1			35	33	8	10
			12	32.9	1			45	41	6	10
			15	40.2	1			60	51	6	10
			18	47.4	1			60	60	4	10
49WA-C	460-3	414-506	0	11.4	1			20	15	14	14
			9	12.8	1			20	16	12	12
			12	16.4	1			25	21	10	10
			15	20	1			30	25	10	10
			18	23.7	1			35	30	8	10
60WA	230/208-1	197-253	0	32.8	1			60	44	6	10
			5	32.8	1			60	44	6	10
			10	45.6	1			60	57	4	10
			15	66.5	1	60	30	90	84	2	8
			20	87.2	1	60	60	110	109	1	6
60WA-B	230/208-3	187-253	0	24.3	1			45	29	8	10
			9	25.7	1			45	33	8	10
			12	32.9	1			45	41	6	10
			15	40.2	1			60	51	6	10
			18	47.4	1			60	60	4	10
60WA-C	460-3	414-506	0	12.4	1			20	15	14	14
			9	12.8	1			20	16	12	12
			12	16.4	1			20	21	10	10
			15	20.0	1			30	25	10	10
			18	23.7	1			35	30	8	10

*Electric heaters are nominal Kw @ 240V or 480V.

**Based on 60°C copper wire. Other wiring materials must be rated for marked minimum circuit ampacity or greater. Not all models are approved for aluminum wire.

① Time delay fuses or "HACR Type" circuit breakers must be used for 60 and smaller sizes. Standard fuses or circuit breakers suitable for sizes 70 and larger.

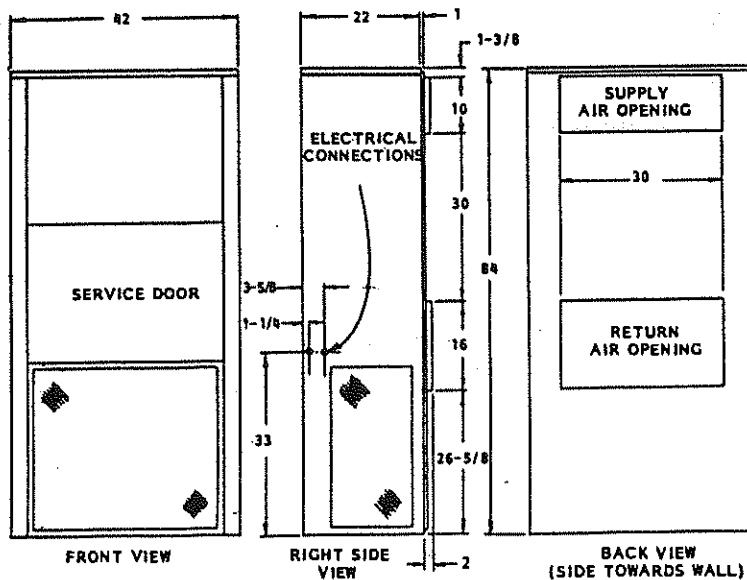

The unit rating plate lists a "Maximum Time Delay Fuse" or "HACR Type" circuit breaker that is to be used with the equipment. The correct size must be used for proper circuit protection and also to assure that there will be no nuisance tripping due to the momentary high starting current of the compressor motor.

PRESSURE SERVICE PORTS

High and low pressure service ports are installed on all units so that the system operating pressures can be observed. Pressure curves can be found later in the manual covering all models on both cooling and heating cycles. It is imperative to match the correct pressure curve to the unit by model number.

CRANKCASE HEATERS

All units are provided with some form of compressor crankcase heat. Some single phase units utilize the compressor motor start winding in series with a portion of the run capacitor to generate heat within the compressor shell to prevent liquid refrigerant migration.

Some three phase units utilize a wraparound type of crankcase heater that warms the compressor oil from the outside.

Some single and three phase models have an insertion well-type heater located in the lower section of the compressor housing. This is a self-regulating type heater that draws only enough power to maintain the compressor at a safe temperature.

Some form of crankcase heat is essential to prevent liquid refrigerant from migrating to the compressor, causing oil pump out on compressor start-up and possible valve failure due to compressing a liquid.

Refer to unit wiring diagram to find exact type of crankcase heater used.

The following decal is affixed to all outdoor units detailing start-up procedure. This is very important. Please read carefully.

IMPORTANT

THESE PROCEDURES MUST BE FOLLOWED AT INITIAL START-UP AND AT ANY TIME POWER HAS BEEN REMOVED FOR 12 HOURS OR LONGER.

TO PREVENT COMPRESSOR DAMAGE WHICH MAY RESULT FROM THE PRESENCE OF LIQUID REFRIGERANT IN THE COMPRESSOR CRANKCASE

1. MAKE CERTAIN THE ROOM THERMOSTAT IS IN THE "OFF" POSITION (THE COMPRESSOR IS NOT TO OPERATE).
2. APPLY POWER BY CLOSING THE SYSTEM DISCONNECT SWITCH THIS ENERGIZES THE COMPRESSOR HEATER WHICH EVAPORATES THE LIQUID REFRIGERANT IN THE CRANKCASE.
3. ALLOW 4 HOURS OR 80 MINUTES PER POUND OF REFRIGERANT IN THE SYSTEM AS NOTED ON THE UNIT RATING PLATE, WHICHEVER IS GREATER.
4. AFTER PROPERLY ELAPSED TIME THE THERMOSTAT MAY BE SET TO OPERATE THE COMPRESSOR.
5. EXCEPT AS REQUIRED FOR SAFETY WHILE SERVICING -- DO NOT OPEN SYSTEM DISCONNECT SWITCH.

7961-061

IMPORTANT INSTALLER NOTE

For improved start-up performance wash the indoor coil with a dishwasher detergent.

NOTE:

If this unit is operated in cooling below a 65° outdoor ambient temperature, the installation of low ambient control (LAC-1) to unit is required.

FAN BLADE SETTING DIMENSIONS

Shown in the drawing below are the correct fan blade setting dimensions for proper air delivery across the outdoor coil.

Any service work requiring removal or adjustment in the fan and/or motor area will require that the dimensions below checked and blade adjusted in or out on the motor accordingly.

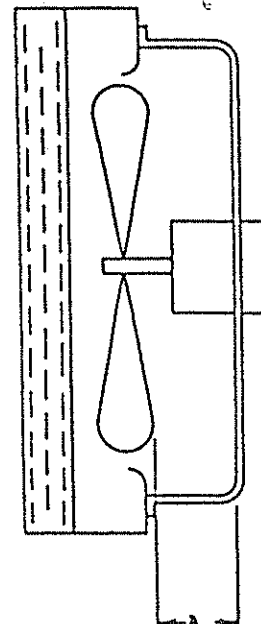

MODEL	DIM. A
42WA	1
49WA	2
60WA	2

REFRIGERANT CHARGE

The correct system R-22 charge is shown on the unit rating plate. Optimum unit performance will occur with a refrigerant charge resulting in a suction line temperature (6" from compressor) as shown in the following table:

MODEL	AIRFLOW	95°F OD Temp.	82°F OD Temp.
42WA	1575	57 - 59	67 - 69
49WA	1725	60 - 62	68 - 70
60WA	1700	54 - 56	63 - 65

The above suction line temperatures are based upon 80° dry bulb/67°F wet bulb (50% R.H.) temperature and rated airflow across the evaporator during cooling cycle.

RATED CFM AND E.S.P. (WET COIL—COOLING)			
MODEL	RATED CFM*	RATED E.S.P.*	RECOMMENDED AIRFLOW RANGE
42WA	1575	.40	1425 - 1700 CFM
49WA	1725	.30	1425 - 1900 CFM
60WA	1700	.20	1425 - 1900 CFM

*Rated CFM and E.S.P. on high speed tap.

INDOOR BLOWER PERFORMANCE CFM--DRY COIL WITH FILTER				
E.S.P. Inches H ₂ O	Models 42WA, 49WA		Model 60WA	
	Low	High	Low	High
.0	1475	2000	1495	2020
.1	1435	1875	1475	1915
.2	1380	1760	1430	1810
.3		1635		1700
.4		1460		1560
.5		1280		1415
.6		1100		1270

RIGHT SIDE VIEW

WALL VIEW

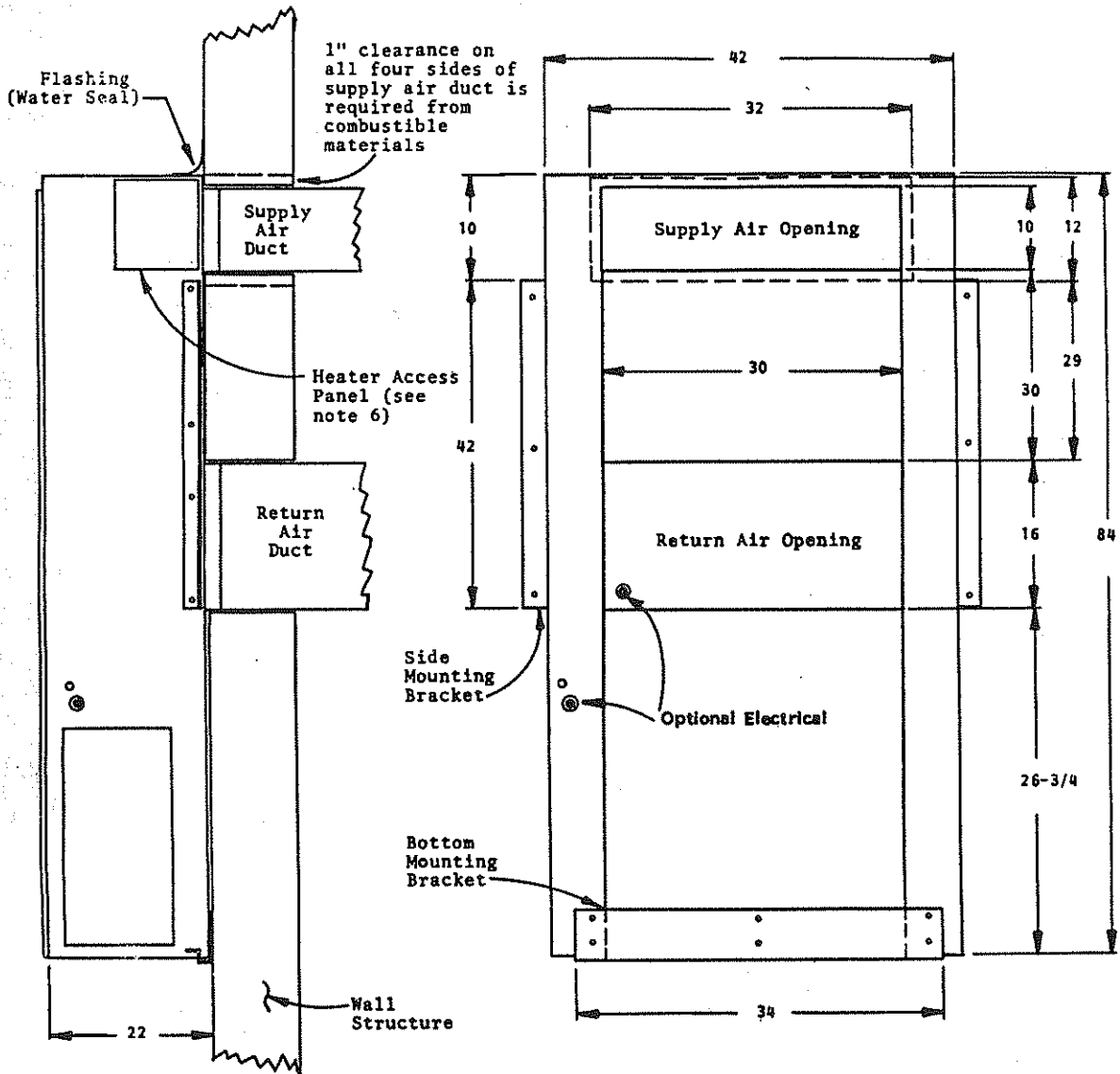

MOUNTING INSTRUCTIONS

1. These units are secured by wall mounting brackets which secure the unit to the outside wall surface at both sides and at the bottom.
2. The unit itself is suitable for "0" inch clearance, but the supply air duct flange and the first few feet of supply air duct require 1 inch clearance to combustible material. If combustible wall, use 30"x10" dimensions for sizing, if non-combustible, use 28"x8" dimensions.
3. After the wall opening positions have been selected, lay out the position for the bottom and side brackets. Fasten the brackets securely to the wall (type of fasteners will depend on wall construction).
4. Be sure to observe the 10" dimension when attaching the side brackets. This will assure that no screws are driven into the unit sides damaging any internal parts. One-half inch sheet metal screws are recommended.
5. For additional mounting rigidity, the return air and supply air (depending upon wall construction) frames or collars can be drilled and screwed or welded to the structural wall itself. Be sure to observe required clearance if combustible wall.
6. Maintain 30 inches minimum clearance on right side of unit to allow access to heat strip.

These curves are based upon 80°DB, 67°WB R.A. Temp. and rated CFM (airflow) across the evaporator coil and should be used for reference purposes only. Special information can be found under section titled "Refrigerant Charge" elsewhere in manual. If there is any doubt as to correct operating charge being in the system, the charge should be removed, system evacuated, and recharged according to serial plate instructions.

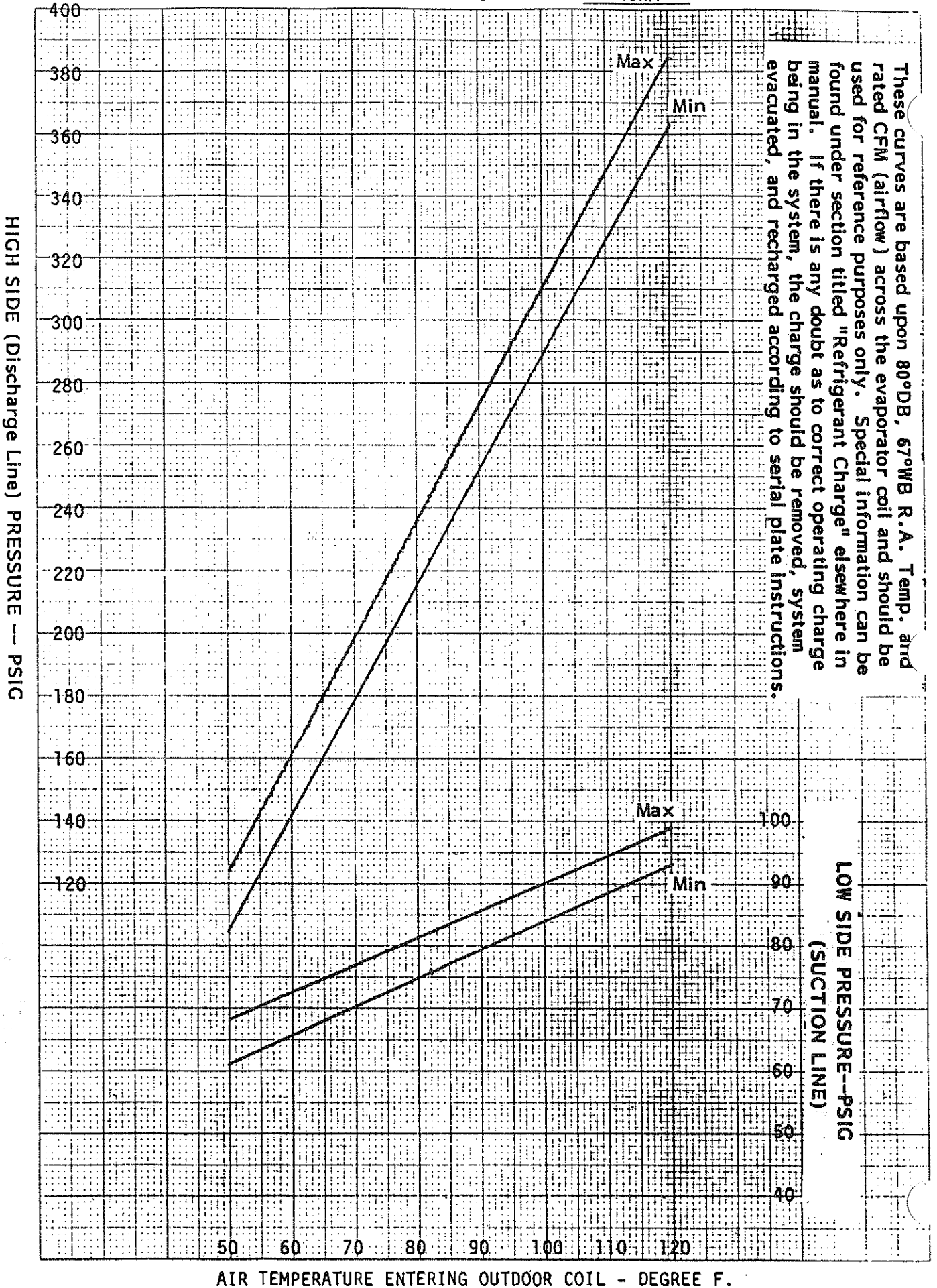

AIR TEMPERATURE ENTERING OUTDOOR COIL - DEGREE F.

© 1997 BY YORK INTERNATIONAL, INC. YORK INTERNATIONAL, INC. YORK INTERNATIONAL, INC. YORK INTERNATIONAL, INC. YORK INTERNATIONAL, INC.

PARTS LIST
SINGLE PACKAGE AIR CONDITIONERS

1/88

Part No.	Description	#2WA-A00N	#2WA-A10N	#2WA-A15N	#2WA-A20N	#2WA-A00C	#2WA-A10C	#2WA-A15C	#2WA-A20C
*	Blower Housing	x	x	x	x	x	x	x	x
5152-011	Blower Wheel DD10-8A	x	x	x	x	x	x	x	x
5152-012	Blower Wheel DD10-8A	x	x	x	x	x	x	x	x
8552-028	Capacitor - Compressor 35/440V	x	x	x	x	x	x	x	x
8552-005	Capacitor - Blower 10/370V	x	x	x	x	x	x	x	x
8552-026	Capacitor - Fan 15/370V	x	x	x	x	x	x	x	x
5811-021	Capillary Tube - Cool	2	2	2	2	2	2	2	2
8000-058	Compressor CRJ3-0300	x	x	x	x	x	x	x	x
5051-027	Condenser Coil	x	x	x	x	x	x	x	x
8401-003	Contacto - Compressor 1P30A	x	x	x	x	x	x	x	x
8401-016	Contacto - 1P35A		1	2	2		1	2	2
8615-015	Circuit Breaker					1			
8615-016	Circuit Breaker						1	1	2
8615-013	Circuit Breaker							1	
5151-027	Fan Blade B2430-4-ccw	x	x	x	x	x	x	x	x
7004-016	Filter 20x30	x	x	x	x	x	x	x	x
8614-022	Fuse 60A			2	2				
8614-006	Fuse 30A			2					
8614-007	Fuse 60A				2				
8614-017	Fuse Block 15kw			x					
8614-018	Fuse Block 20kw				x				
8604-044	Heat Strip 10kw		1		2		1		2
8604-047	Heat Strip 15kw			1				1	
8402-047	Limit Switch L180-7		1	1	1		1	1	1
8106-023	Motor - Blower 1/2 hp	x	x	x	x	x	x	x	x
8105-021	Motor - Fan 1/3 hp	x	x	x	x	x	x	x	x
8201-009	Relay - Blower	x	x	x	x	x	x	x	x
8200-004	Motor Mount - Fan	x	x	x	x	x	x	x	x
5210-005	Strainer	x	x	x	x	x	x	x	x
8607-018	Terminal Board 24V	x	x	x	x	x	x	x	x
8607-013	Terminal Block 230V	x	x						
8402-032	Thermal Cutoff		2	3	4		2	3	4
8407-034	Transformer 40VA	x	x	x	x	x	x	x	x
4010-110	Wiring Diagram	x							
4010-111	Wiring Diagram					x			
4010-130	Wiring Diagram		x						
4010-131	Wiring Diagram						x		
4010-140	Wiring Diagram			x					
4010-141	Wiring Diagram							x	
4010-150	Wiring Diagram				x				
4010-151	Wiring Diagram								x
5060-025	Evaporator Coil	x	x	x	x	x	x	x	x

*Please order by model number.

PARTS LIST
SINGLE PACKAGE AIR CONDITIONERS

1/88

Part No.	Description	49WA-B00N	49WA-B09N	49WA-B15N	49WA-B18N	49WA-B00C	49WA-B90C	49WA-B15C	49WA-B18C	49WA-B00H	49WA-B09H	49WA-B18H
*	Blower Housing	x	x	x	x	x	x	x	x	x	x	x
5152-011	Blower Wheel DD10-8A	x	x	x	x	x	x	x	x	x	x	x
5152-012	Blower Wheel DD10-8A	x	x	x	x	x	x	x	x	x	x	x
8552-005	Capacitor - Blower 10/370V	x	x	x	x	x	x	x	x	x	x	x
8552-026	Capacitor - Fan 15/370V	x	x	x	x	x	x	x	x	x	x	x
5811-020	Capillary Tube - Cool	2	2	2	2	2	2	2	2			
8000-064	Compressor CRK3-0325	x	x	x	x	x	x	x	x	x	x	x
5051-028	Condenser Coil	x	x	x	x	x	x	x	x	x	x	x
8401-002	Contactoer - 3P25A	1	1	1	1	1	1	1	1	1	1	1
8401-006	Contactoer - Heater 24V		1	2	2		1	2	2		1	2
8615-019	Circuit Breaker					1	1					
8615-011	Circuit Breaker							1	1			
5060-025	Evaporator Coil	x	x	x	x	x	x	x	x	x	x	x
5151-027	Fan Blade B2430-4 ccw	x	x	x	x	x	x	x	x	x	x	x
7004-016	Filter 20x30	x	x	x	x	x	x	x	x	x	x	x
8604-047	Heat Strip 15kw			1				1				
8604-048	Heat Strip 9kw		1		2		1		2		1	2
8402-047	Limit Switch L180-7		x	x	x		x	x	x		x	x
8106-023	Motor - Blower 1/2 hp	x	x	x	x	x	x	x	x	x	x	x
8105-021	Motor - Fan 1/3 hp	x	x	x	x	x	x	x	x	x	x	x
8200-004	Motor Mount - Fan	x	x	x	x	x	x	x	x	x	x	x
8201-009	Relay - Blower	x	x	x	x	x	x	x	x	x	x	x
5210-005	Strainer	x	x	x	x	x	x	x	x			
8607-018	Terminal Board 24V	x	x	x	x	x	x	x	x	x	x	x
8607-014	Terminal Block 230V	x	x	x	x					x	x	x
8402-032	Thermal Cutoff		2	3	4		2	3	4		2	4
8407-034	Transformer 40VA	x	x	x	x	x	x	x	x	x	x	x
4010-210	Wiring Diagram	x								x		
4010-211	Wiring Diagram					x						
4010-220	Wiring Diagram		x								x	
4010-221	Wiring Diagram						x					
4010-230	Wiring Diagram			x								
4010-231	Wiring Diagram							x				
4010-240	Wiring Diagram				x							x
4010-241	Wiring Diagram								x			

*Please order by model number.

PARTS LIST
SINGLE PACKAGE AIR CONDITIONERS

Part No.	Description	60WA-A00N	60WA-A10N	60WA-A15N	60WA-A20N	60WA-A00C	60WA-A10C	60WA-A15C	60WA-A20C	60WA-A00H	60WA-A10H	60WA-A20H
*	Blower Housing	x	x	x	x	x	x	x	x	x	x	x
5152-011	Blower Wheel DD10-8A	x	x	x	x	x	x	x	x	x	x	x
5152-012	Blower Wheel DD10-8A	x	x	x	x	x	x	x	x	x	x	x
8552-005	Capacitor - Blower 10/370V	x	x	x	x	x	x	x	x	x	x	x
8552-026	Capacitor - Fan 15/370V	x	x	x	x	x	x	x	x	x	x	x
8552-031	Capacitor - Compressor 45/440V	x	x	x	x	x	x	x	x	x	x	x
5811-032	Capillary Tube - Cool	2	2	2	2	2	2	2	2			
8000-091	Compressor H23A543ABCA	x	x	x	x	x	x	x	x	x	x	x
5051-028	Condenser Coil	x	x	x	x	x	x	x	x	x	x	x
8401-006	Contactor - Heater 24V		1	2	2		1	2	2		1	2
8401-016	Contactor - 1P35A	x	x	x	x	x	x	x	x	x	x	x
8615-016	Circuit Breaker					1	1	1	2			
8615-013	Circuit Breaker							1				
5060-039	Evaporator Coil	x	x	x	x	x	x	x	x	x	x	x
5151-027	Fan Blade B2430-4 ccw	x	x	x	x	x	x	x	x	x	x	x
7004-016	Filter 20x30	x	x	x	x	x	x	x	x	x	x	x
8614-022	Fuse 60A			2	2							2
8614-006	Fuse 30A			2								2
8614-007	Fuse 60A				2							2
8614-017	Fuse Block 15kw			1								1
8614-018	Fuse Block 20kw				1							1
8604-044	Heat Strip 10kw		1		2		1		2		1	2
8604-047	Heat Strip 15kw			1				1				
8402-047	Limit Switch L180-7		x	x	x		x	x	x		x	x
8106-023	Motor - Blower 1/2 hp	x	x	x	x	x	x	x	x	x	x	x
8105-021	Motor - Fan 1/3 hp	x	x	x	x	x	x	x	x	x	x	x
8200-004	Motor Mount - Fan	x	x	x	x	x	x	x	x	x	x	x
8201-009	Relay - Blower	x	x	x	x	x	x	x	x	x	x	x
5210-005	Strainer	x	x	x	x	x	x	x	x			
8607-018	Terminal Board 24V	x	x	x	x	x	x	x	x	x	x	x
8607-013	Terminal Block 230V	x	x							x	x	
8402-032	Thermal Cutoff		2	3	4		2	3	4		2	4
8407-034	Transformer 40VA	x	x	x	x	x	x	x	x	x	x	x
4010-110	Wiring Diagram	x								x		
4010-111	Wiring Diagram					x						
4010-130	Wiring Diagram		x								x	
4010-131	Wiring Diagram						x					
4010-140	Wiring Diagram			x								
4010-141	Wiring Diagram							x				
4010-150	Wiring Diagram				x							x
4010-151	Wiring Diagram								x			

*Please order by model number.

PARTS LIST
SINGLE PACKAGE AIR CONDITIONERS

1/88

Part No.	Description	60WA-C00N	60WA-C09N	60WA-C15N	60WA-C18N	60WA-C00C	60WA-C09C	60WA-C15C	60WA-C18C	60WA-C00H	60WA-C09H	60WA-C18H
*	Blower Housing	x	x	x	x	x	x	x	x	x	x	x
5152-011	Blower Wheel DD10-8A	x	x	x	x	x	x	x	x	x	x	x
5152-012	Blower Wheel DD10-8A	x	x	x	x	x	x	x	x	x	x	x
8552-005	Capacitor - Blower 10/370V	x	x	x	x	x	x	x	x	x	x	x
8552-026	Capacitor - Fan 15/370V	x	x	x	x	x	x	x	x	x	x	x
5811-032	Capillary Tube - Cool	2	2	2	2	2	2	2	2			
8000-048	Compressor AG122UT	x	x	x	x	x	x	x	x	x	x	x
5051-028	Condenser Coil	x	x	x	x	x	x	x	x	x	x	x
8401-002	Contactora - 3P25A	1	2	2	3	1	2	2	3	1	2	3
8615-024	Circuit Breaker					1	1					
8615-026	Circuit Breaker							1				
8615-027	Circuit Breaker								1			
5060-039	Evaporator Coil	x	x	x	x	x	x	x	x	x	x	x
5151-027	Fan Blade B2430-4 ccw	x	x	x	x	x	x	x	x	x	x	x
7004-016	Filter 20x30	x	x	x	x	x	x	x	x	x	x	x
8604-050	Heat Strip 9kw		1				1				1	
8604-052	Heat Strip 15kw			1				1				
8604-087	Heat Strip 18kw 460v				2				2			2
8402-047	Limit Switch L180-7		x	x	x		x	x	x		x	x
8106-024	Motor - Blower	x	x	x	x	x	x	x	x	x	x	x
8105-030	Motor - Fan	x	x	x	x	x	x	x	x	x	x	x
8200-004	Motor Mount - Fan	x	x	x	x	x	x	x	x	x	x	x
8201-032	Relay - Blower	x	x	x	x	x	x	x	x	x	x	x
8607-015	Phenolic Insulator	x	x	x	x					x	x	x
5210-005	Strainer	x	x	x	x	x	x	x	x			
8607-018	Terminal Board 24V	x	x	x	x	x	x	x	x	x	x	x
8607-014	Terminal Block 230V	x	x	x	x					x	x	x
8402-032	Thermal Cutoff		3	3	6		3	3	6		3	6
8407-027	Transformer 48VA	x	x	x	x	x	x	x	x	x	x	x
4010-310	Wiring Diagram	x								x		
4010-311	Wiring Diagram					x						
4010-320	Wiring Diagram		x	x							x	
4010-321	Wiring Diagram						x	x				
4010-330	Wiring Diagram				x							x
4010-331	Wiring Diagram								x			

*Please order by model number.

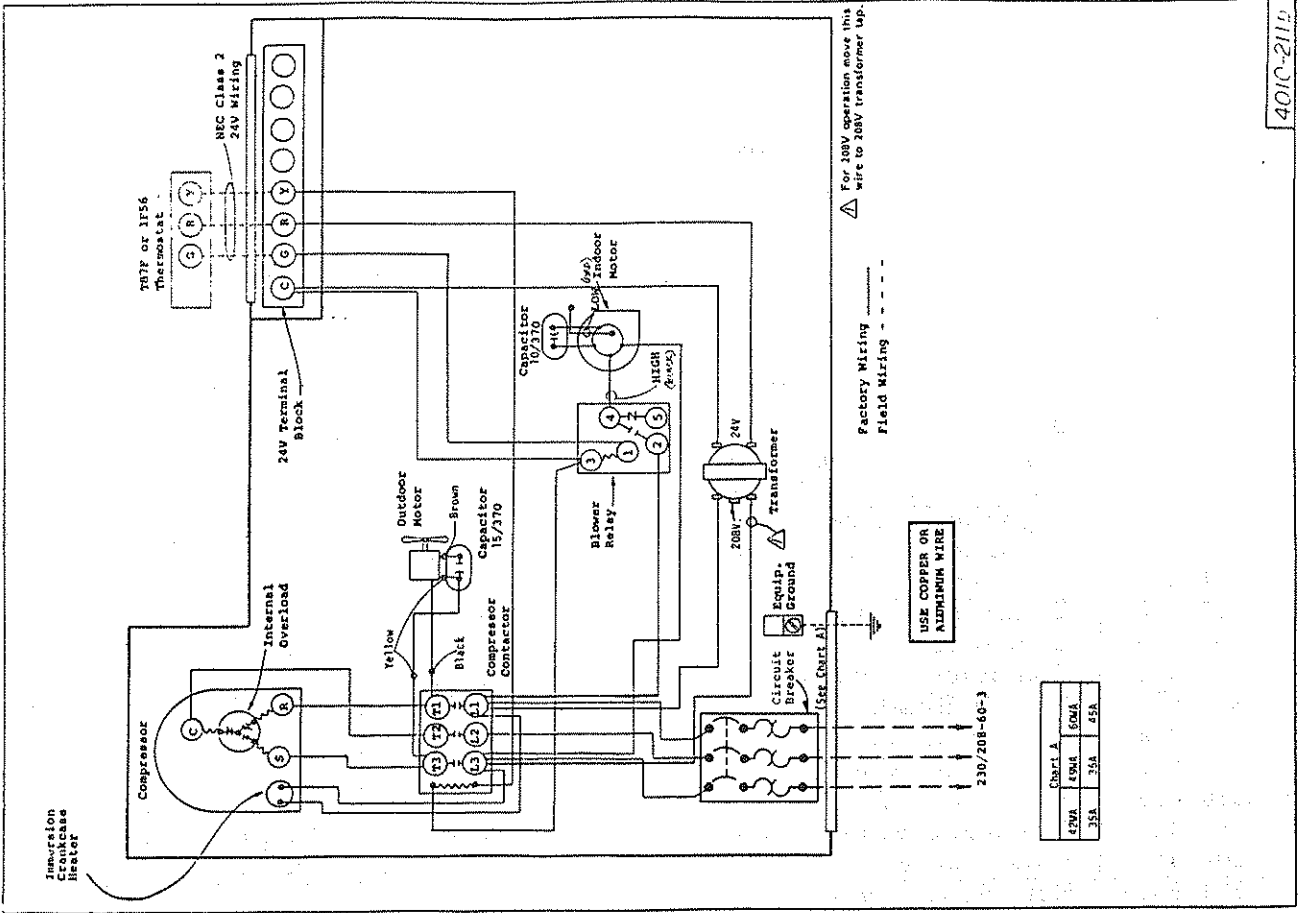

4010-211P

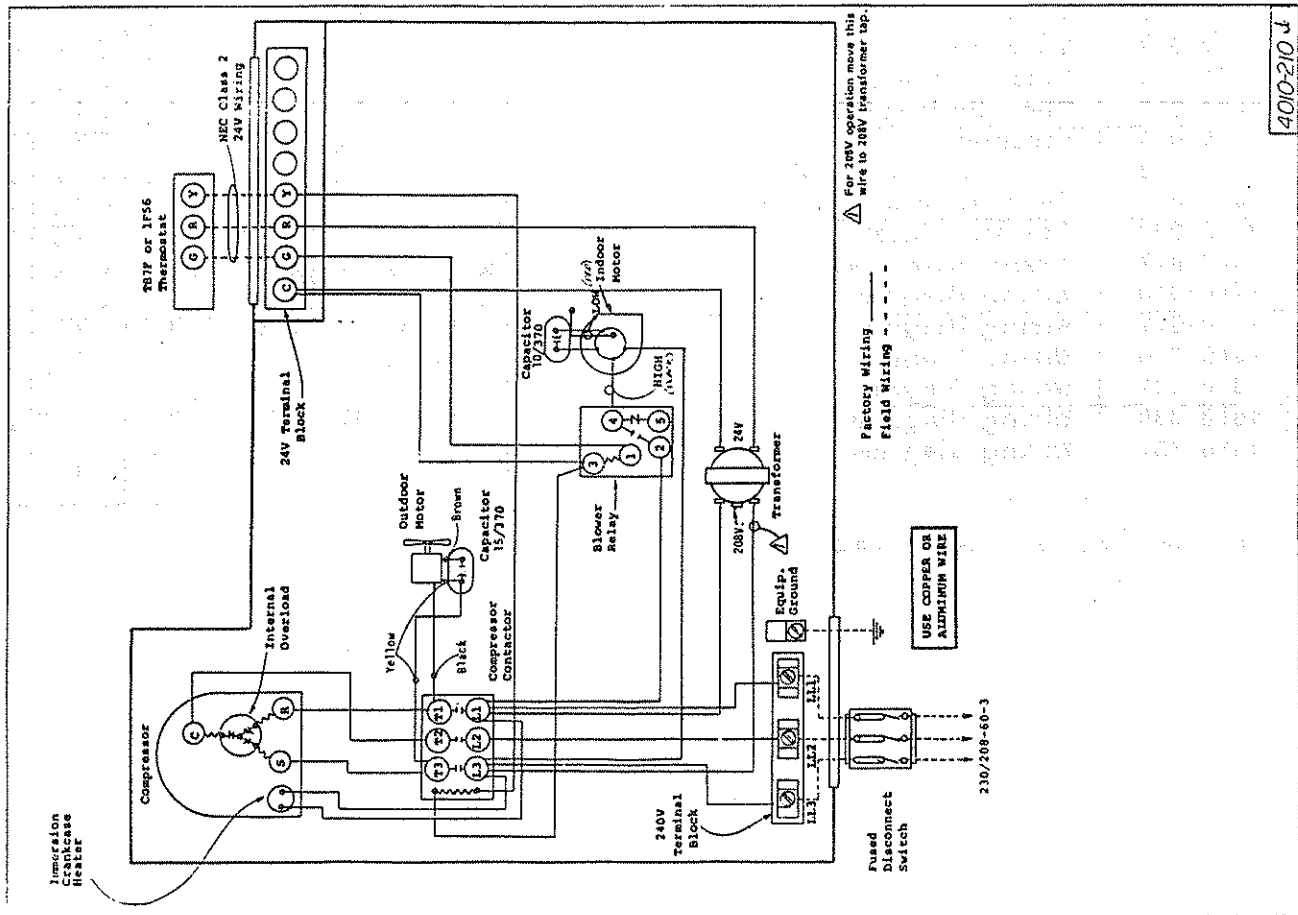

4010-210 J

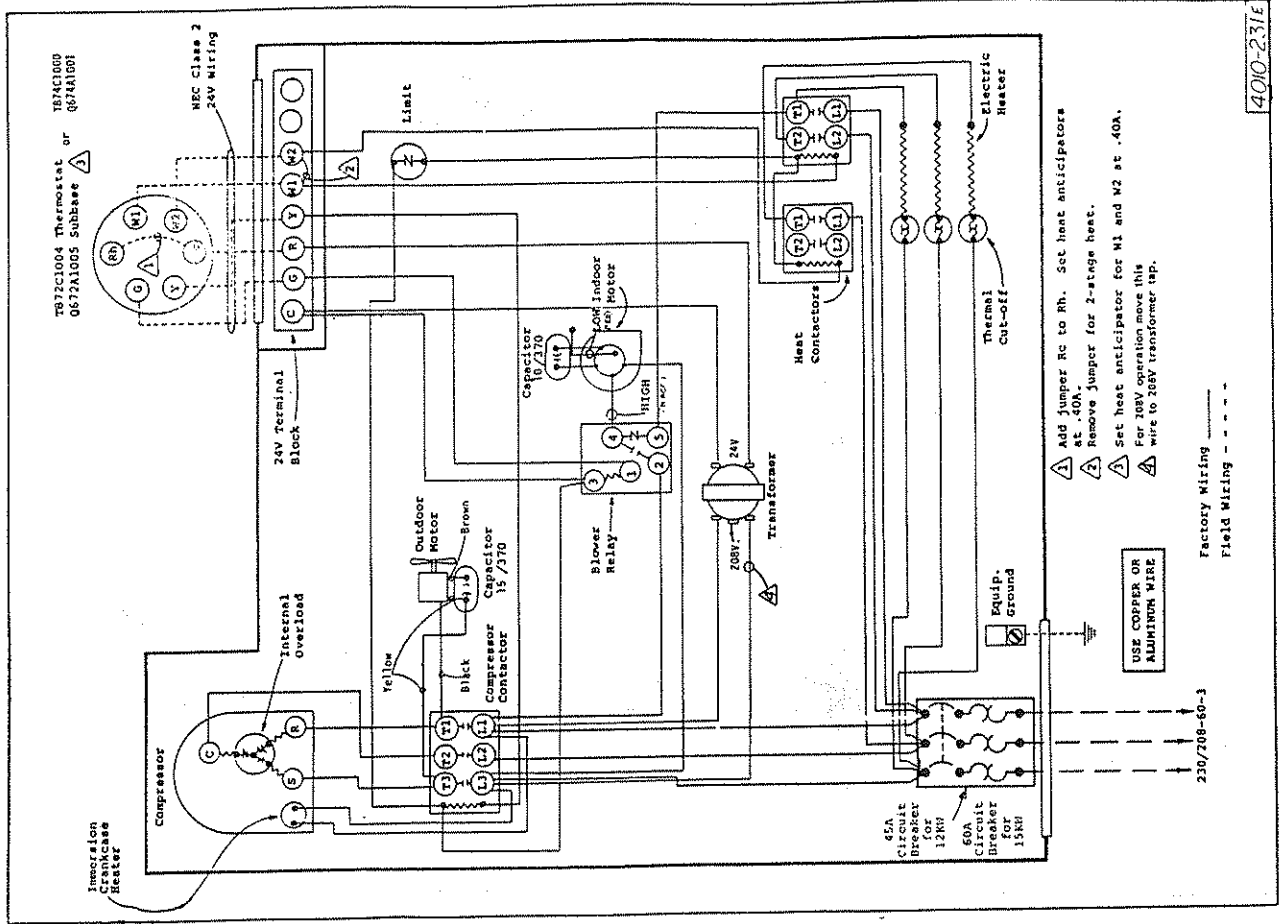
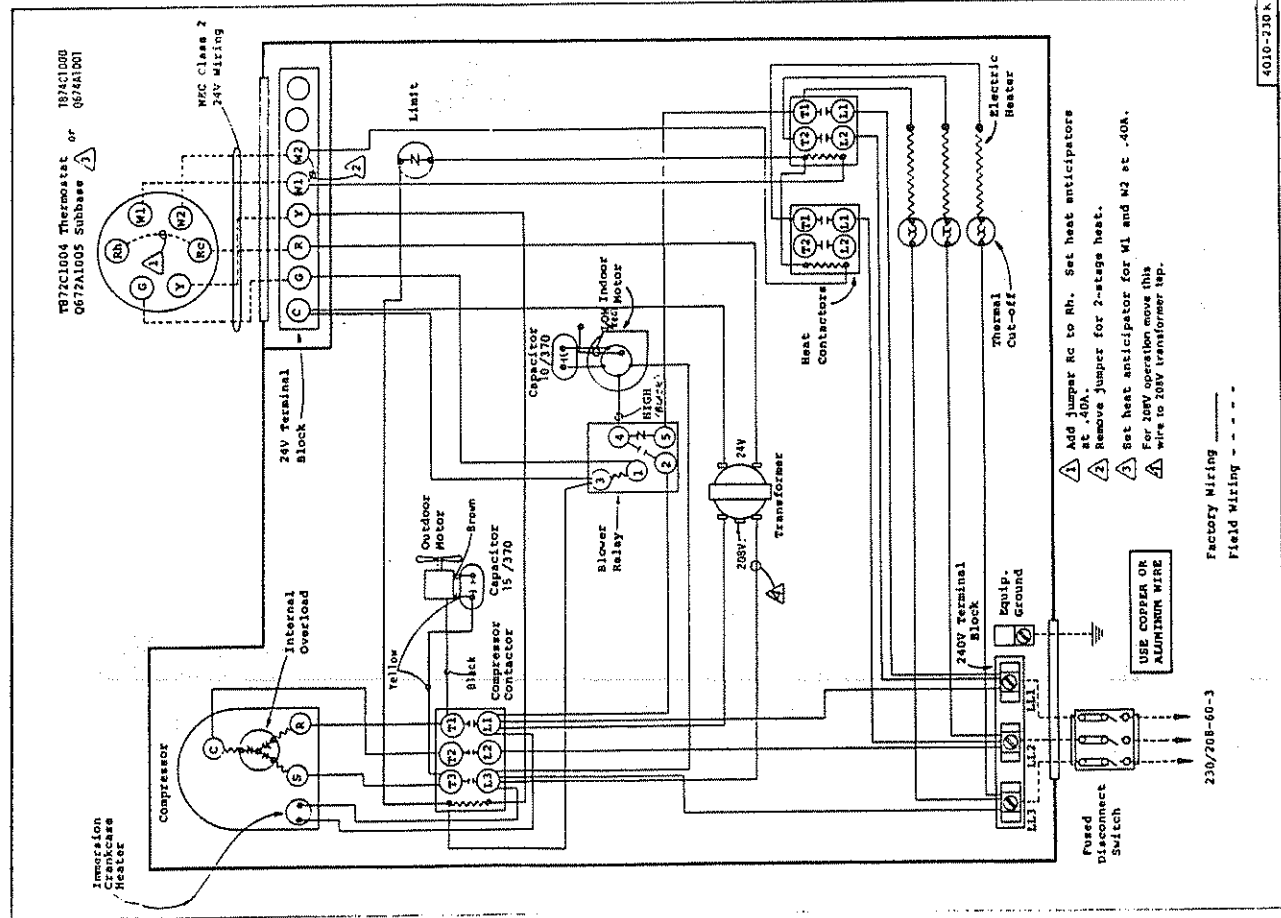

- ⚠ Add jumper Rc to Rh. Set heat anticipators at .40A.
- ⚠ Remove jumper for 2-stage heat.
- ⚠ Set heat anticipator for M1 and M2 at .40A.
- ⚠ For 208V operation move this wire to 208V transformer tap.

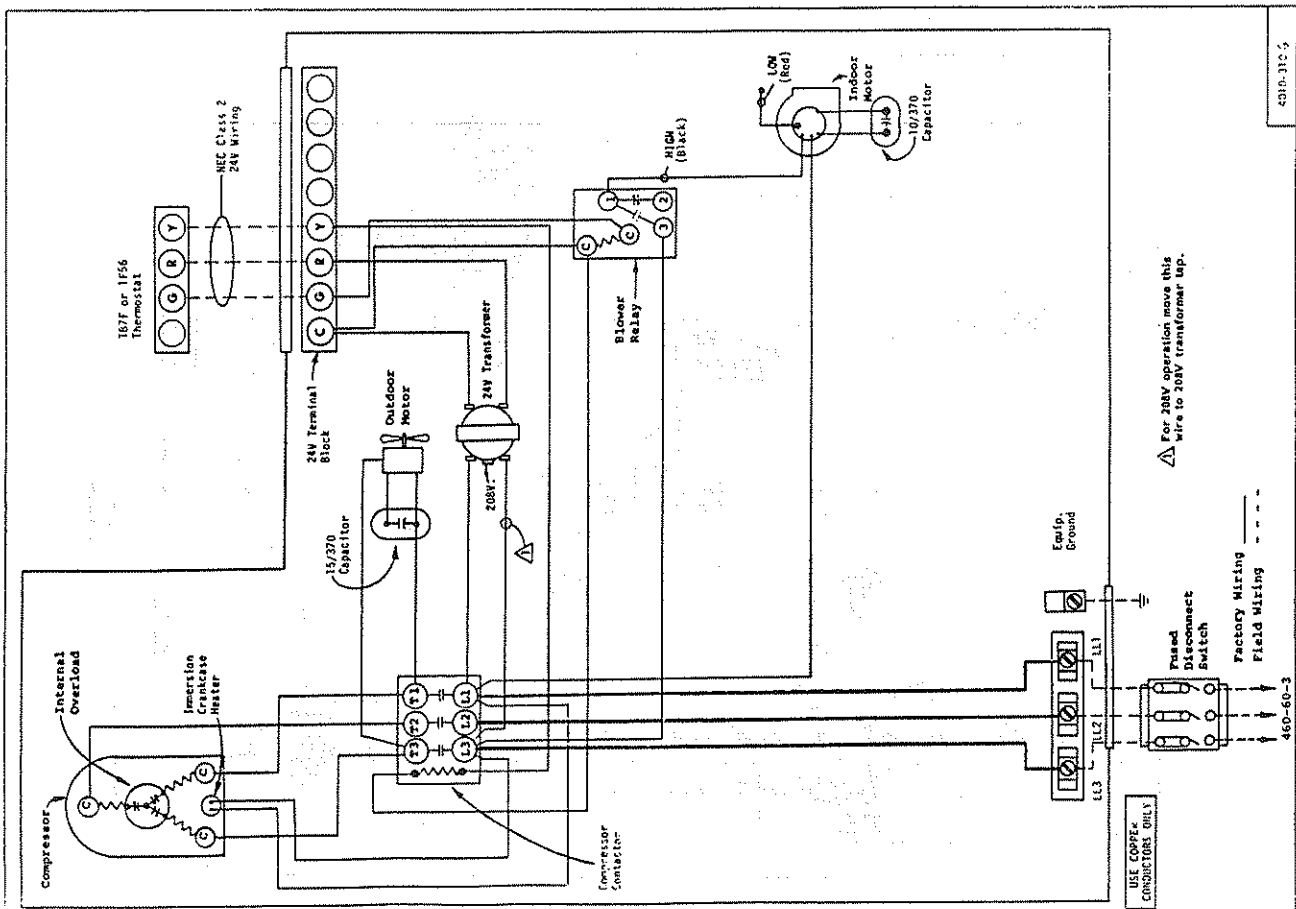

460-50-3

For 208V operation move this wire to 208V transformer tap.

USE COPPER CONDUCTORS ONLY

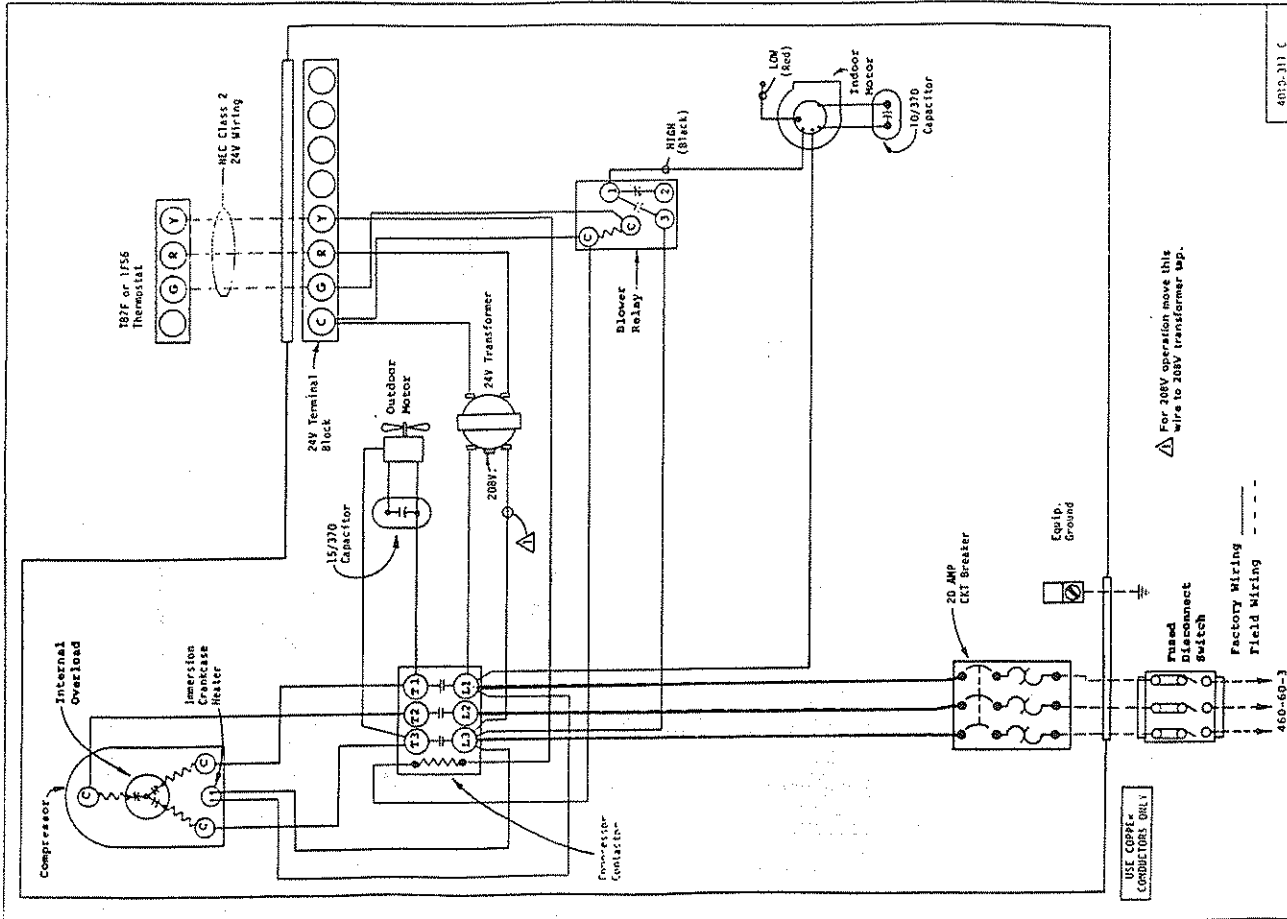

460-60-3

For 208V operation move this wire to 208V transformer tap.

USE COPPER CONDUCTORS ONLY

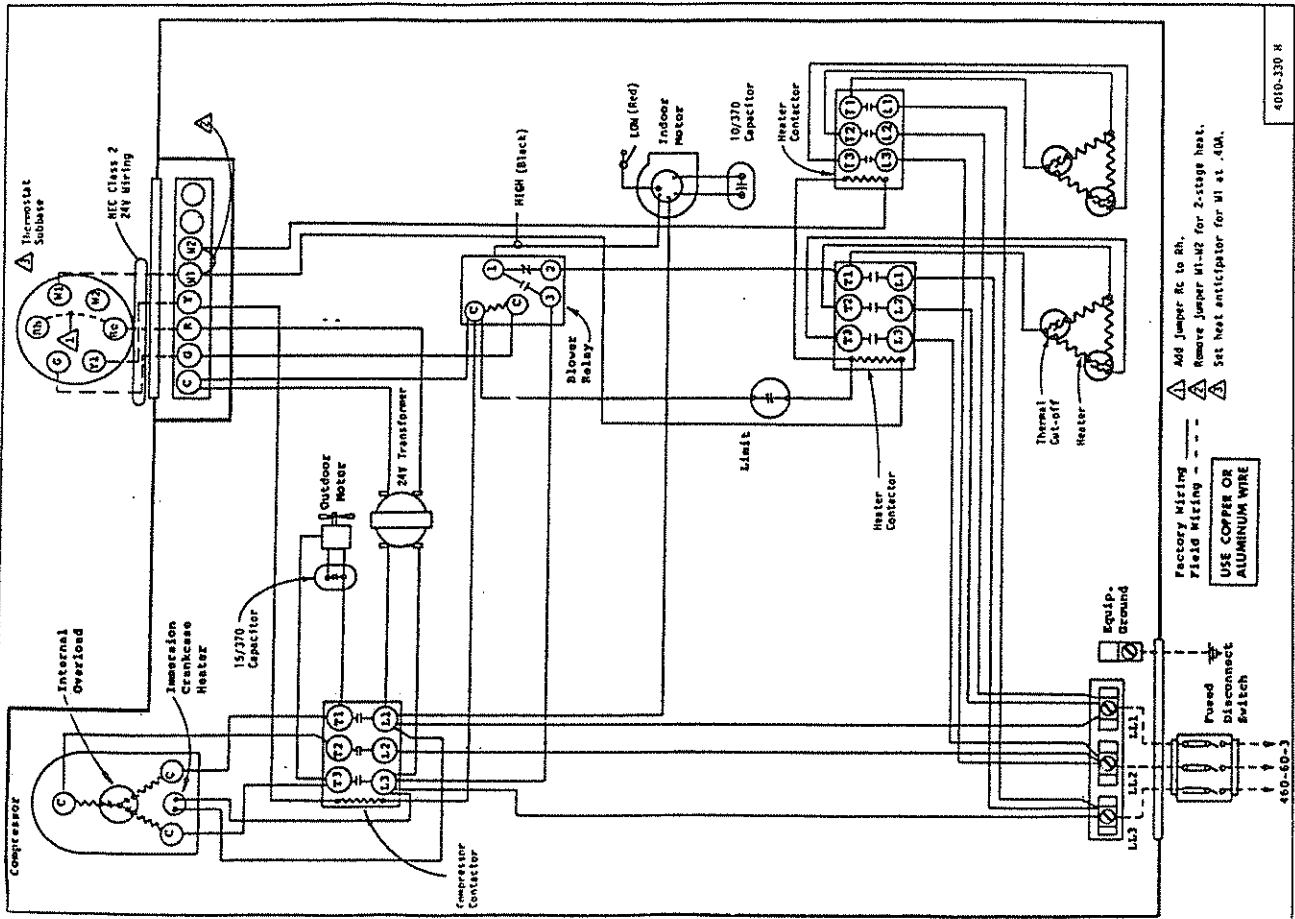
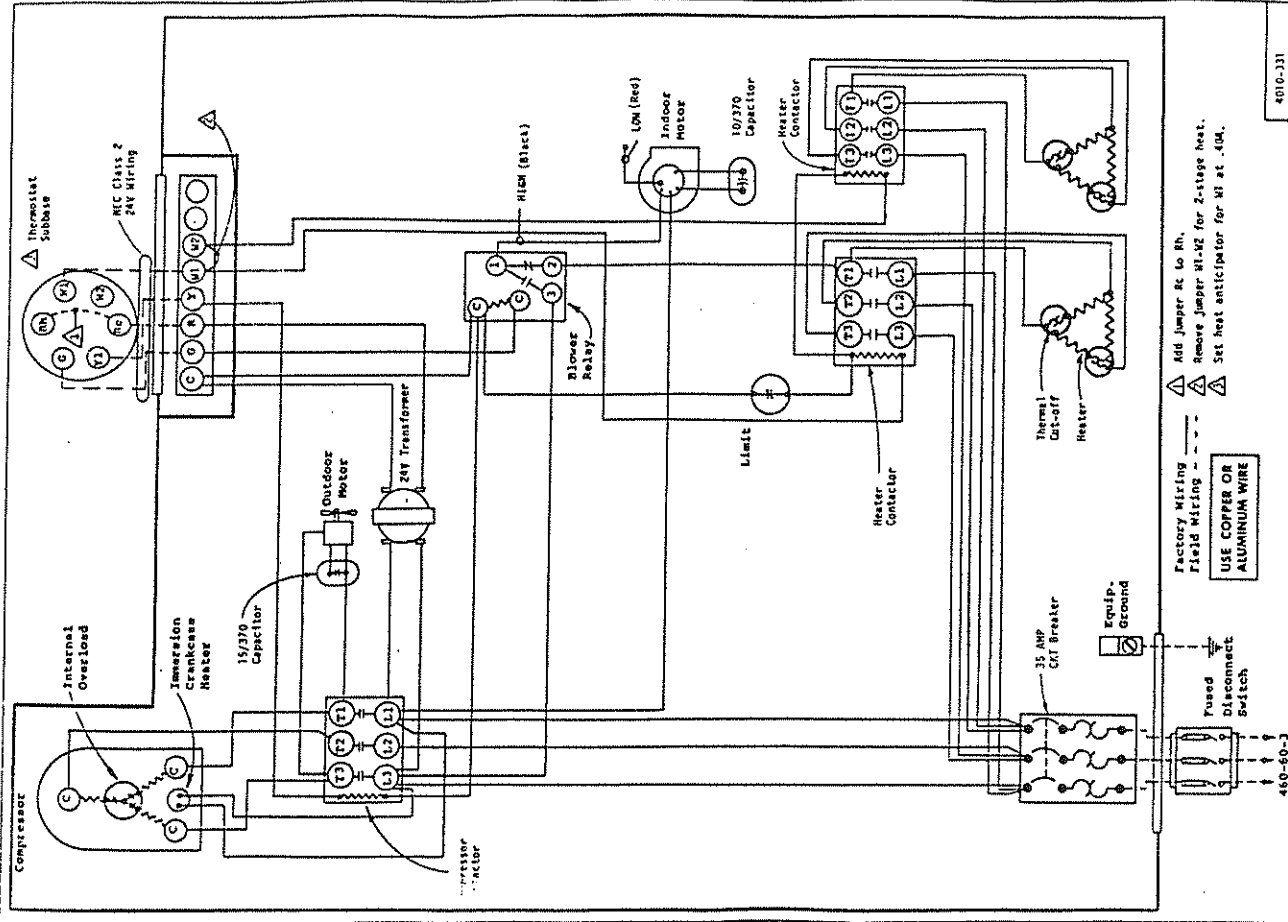

...the ... of ...

...the ... of ...

...the ... of ...

...the ... of ...

