

**INSTALLATION INSTRUCTIONS**

**WALL MOUNTED  
PACKAGE AIR CONDITIONERS**

**MODELS**

**20WA2**

**24WA5**

ELECTRICAL INFORMATION								WIRING INFORMATION		
MODEL	Rated Volts & Ph	Operating Voltage Range	Heater* KW	Max Unit Amps	No. Field Power Circuits	Internal Fuses Ckt. A/B	Required  Overcurrent Protection	Min. Ckt. Ampacity Ckt. A/B	Field Power Wiring Ckt. A/B	Ground Wire Size Ckt. A/B
20WA2	230/208-1	197-253	0	10.5	1		20	15	14	12
			4	18.0	1		25	23	10	10
			5	22.1	1		30	28	10	10
			8	34.6	1		45	44	6	10
			10	42.9	1		60	54	6	10
20WA3	230/208-1	197-253	0	14.5	1		30	19	12	12
			4	18.0	1		25	23	10	10
			5	22.1	1		30	28	10	10
			8	34.6	1		45	44	6	10
			10	42.9	1		60	54	6	10

\*Electric heaters are nominal Kw @ 240V or 480V.

\*\*Based on 60°C copper wire. Other wiring materials must be rated for marked "minimum circuit ampacity" or greater. Not all models approved for aluminum wire.

 Time delay fuses or "NACR Type" circuit breakers must be used for 60 and smaller sizes. Standard fuses or circuit breakers are suitable for 70 and larger.

## IMPORTANT

The equipment covered in this manual is to be installed by trained, experienced service and installation technicians. Any heat pump is more critical of proper operating, charge and an adequate duct system than a straight air conditioning unit. All duct work supply and return, must be properly sized for the design air flow requirement of the equipment. ACCA is an excellent guide to proper sizing. All duct work or portions thereof not in the conditioned space should be properly insulated in order to both conserve energy and prevent condensation or moisture damage.

## SHIPPING DAMAGE

Upon receipt of equipment, the carton should be checked for external signs of shipping damage. If damage is found, the receiving party must contact the last carrier immediately, preferably in writing, requesting inspection by the carrier's agent.

## GENERAL

The refrigerant system is completely assembled and charged. All internal wiring is complete.

The unit is designed for use with or without duct work. Flanges are provided for attaching the supply and return ducts.

These instructions explain the recommended method to install the air cooled self-contained unit and the electrical wiring connections to the unit.

These instructions and any instructions packaged with any separate equipment required to make up the entire air conditioning system should be carefully read before beginning the installation. Note particularly "Starting Procedure" and any tags and/or labels attached to the equipment.

While these instructions are intended as a general recommended guide, they do not supersede any national and/or local codes in any way. Authorities having jurisdiction should be consulted before the installation is made.

## INSTALLATION

Size of unit for a proposed installation should be based on heat loss calculation made according to methods of Air Conditioning Contractors of America (ACCA). The air duct should be installed in accordance with the Standards of the National Fire Protection Association for the Installation of Air Conditioning and Ventilation systems of Other Than Residence Type, NFPA No. 98A, and Residence Type Warm Air Heating and Air Conditioning Systems, NFPA No. 90B. Where local regulations are at a variance with instructions, installer should adhere to local codes.

## DUCT WORK

Design the duct work according to methods given by the Air Conditioning Contractors of America. When duct runs through unheated spaces, it should be insulated with a minimum of one inch of insulation. Use insulation with a vapor barrier on the outside of the insulation. Flexible joints should be used to connect the duct work to the equipment in order to keep the noise transmission to a minimum.

A one-inch clearance to combustible material for the first three feet of duct attached to the outlet air frame is required. See page 5 for further details.

## FILTER

A one inch throwaway filter is supplied with each unit. The filter slides into position making it easy to service. This filter can be serviced from the outside by removing the service door.

## FRESH AIR INTAKE

All units are built with a fresh air inlet hole punched in the service panel. The fresh air damper assembly is shipped with each unit, and must be attached at the installation site. See Figure 1 for typical installation procedure.

The fresh air damper assembly is standard equipment with the unit because of the variety of state or local codes requiring fresh air capability.

All capacity, efficiency and cost of operation information as required for Department of Energy "Energyguide" Fact Sheets is based upon the fresh air blank-off plate in place and is recommended for maximum energy efficiency.

The blank-off plate is available upon request from the factory and is installed in place of the fresh air damper shipped with each unit.

## WALL MOUNTING

1. Two holes, the size of the supply and return air openings must be cut through the wall as shown in Figure 2.
2. On wood-frame walls, the wall construction must be strong and rigid enough to carry the weight of the unit without transmitting any unit vibration.
3. Concrete block walls must be thoroughly inspected to insure that they are capable of carrying the weight of the installing unit.
4. Ducts through the walls must be insulated and all joints taped or sealed to prevent air or moisture entering the wall cavity.
5. Some installations may not require any return air duct. It is recommended that on this type of installation that a filter grille be located in the wall. Filters must be of sufficient size to allow a maximum velocity of 400 FPM.

NOTE: If no return air duct is used, applicable installation codes may limit this cabinet to installation only in a single story structure.

## WIRING - MAIN POWER

Refer to the unit rating plate for wire sizing information and maximum fuse or "HACR Type" circuit breaker size. Each outdoor unit is marked with a "Minimum Circuit Ampacity." This means that the field wiring used must be sized to carry that amount of current. Depending on the installed Kw of electric heat, there may be two field power circuits required. If this is the case, the unit serial plate will so indicate. Some models are suitable only for connection with copper wire, while others can be wired with either copper or aluminum wire. Each unit and/or wiring diagram will be marked "Use Copper Conductors Only" or "Use Copper or Aluminum Conductors." These instructions MUST BE adhered to. Refer to the National Electrical Code for complete current carrying capacity data on the various insulation grades of wiring material.

The electrical data lists fuse and wire sizes (60°C copper) for all models, including the most commonly used heater sizes. Also shown are the number of field power circuits required for the various models with heaters.

The unit rating plate lists a "Maximum Time Delay Relay Fuse" or "HACR Type" circuit breaker that is to be used with the equipment. The correct size must be used for proper circuit protection and also to assure that there will be no nuisance tripping due to the momentary high starting current of the compressor motor.

### FAN BLADE SETTING DIMENSIONS

Shown in the drawing below are the correct fan blade setting dimensions for proper air delivery across the outdoor coil.

Any service work requiring removal or adjustment in the fan and/or motor area will require that the dimensions below be checked and blade adjusted in or out on the motor shaft accordingly.

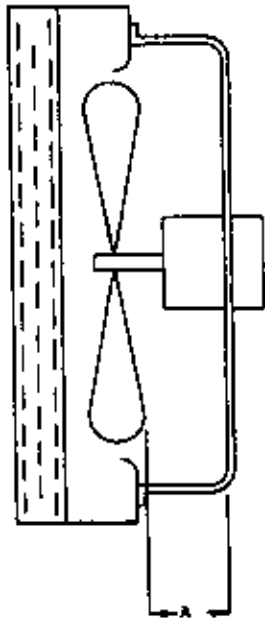

MODEL	DIM. A
20WA2	1/2
24WA5	1/2

### REFRIGERANT CHARGE

The correct system R-22 charge is shown on the unit rating plate. Optimum unit performance will occur with a refrigerant charge resulting in a suction line temperature (5' from compressor) as shown in the following table:

Model	Rated Airflow	95°F OD Temp.	82°F OD Temp.
20WA2	710	52 - 59	64 - 66
24WA5	860	54 - 56	61 - 63

The above suction line temperatures are based upon 80°F dry bulb/67°F wet bulb (50% R.H.) temperature and rated airflow across the evaporator during cooling cycle.

INDOOR BLOWER PERFORMANCE CFM--DRY COIL WITH FILTER	
E.S.P. Inches H <sub>2</sub> O	Model 20WA2-24WA5
.0	1065
.1	1040
.2	970
.3	910
.4	830
.5	730

### PRESSURE SERVICE PORTS

High and low pressure service ports are installed on all units so that the system operating pressures can be observed. Pressure curves can be found later in the manual covering all models on both cooling and heating cycles. It is imperative to match the correct pressure curve to the unit by model number.

RATED CFM AND E.S.P. (WET COIL--COOLING)			
Model	Rated CFM	Rated E.S.P.	Recommended Airflow Range
20WA2	710	.29	640 - 800
24WA5	815	.15	725 - 900

### IMPORTANT INSTALLER NOTE

For improved start-up performance wash the indoor coil with a dishwasher detergent.

### CRANKCASE HEATERS

All units are provided with some form of compressor crankcase heat. Some single phase units utilize the compressor motor start winding in series with a portion of the run capacitor to generate heat within the compressor shell to prevent liquid refrigerant migration.

Some three phase units utilize a wraparound type of crankcase heater that warms the compressor all from the outside.

Some single and three phase models have an insertion wall-type heater located in the lower section of the compressor housing. This is a self-regulating type heater that draws only enough power to maintain the compressor at a safe temperature.

Some form of crankcase heat is essential to prevent liquid refrigerant from migrating to the compressor, causing oil pump out on compressor start-up and possible valve failure due to compressing a liquid.

Refer to unit wiring diagram to find exact type of crankcase heater used.

The following decal is affixed to all outdoor units detailing start-up procedure. This is very important. Please read carefully.

### IMPORTANT

THESE PROCEDURES MUST BE FOLLOWED AT INITIAL START-UP AND AT ANY TIME POWER HAS BEEN REMOVED FOR 12 HOURS OR LONGER.

TO PREVENT COMPRESSOR DAMAGE WHICH MAY RESULT FROM THE PRESENCE OF LIQUID REFRIGERANT IN THE COMPRESSOR CRANKCASE:

1. MAKE CERTAIN THE ROOM THERMOSTAT IS IN THE "OFF" POSITION (THE COMPRESSOR IS NOT TO OPERATE).
2. APPLY POWER BY CLOSING THE SYSTEM DISCONNECT SWITCH. IMMEDIATELY THE COMPRESSOR HEATER WHICH EVAPORATES THE LIQUID REFRIGERANT IN THE CRANKCASE.
3. ALLOW 4 HOURS OR 60 MINUTES PER ROUND OF APPROXIMATELY IN THE SYSTEM AS NOTED ON THE UNIT RATING PLATE, WHICHEVER IS GREATER.
4. AFTER PROPERLY ELAPSED TIME THE THERMOSTAT MAY BE SET TO OPEN THE COMPRESSOR.
5. EXCEPT AS REQUIRED FOR SAFETY WHILE REPAIRING - DO NOT OPEN SYSTEM DISCONNECT SWITCH.

1961-081

Note: If this unit is operated in cooling below a 55° outdoor ambient temperature, the installation of low ambient control (LAC-1) to unit is required.

**UNIT MODELS**

20WA  
24WA  
18WH  
24WH

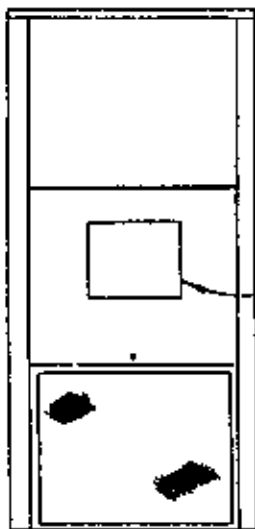

Model FAD10  
Fresh Air Cover  
With Adjustable  
Damper

**UNIT MODELS**

30WA  
36WA  
36WH  
42WA  
48WA  
60WA  
48WH  
60WH

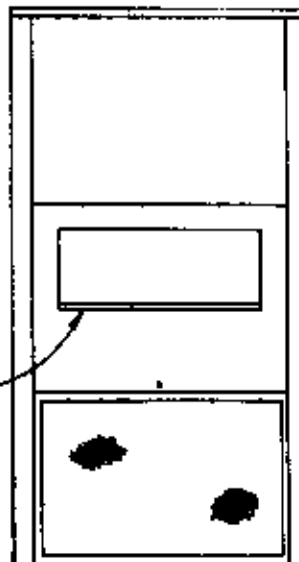

MODEL FAD25  
Fresh Air Cover  
With Adjustable  
Damper

Service  
Door

Model FAD10

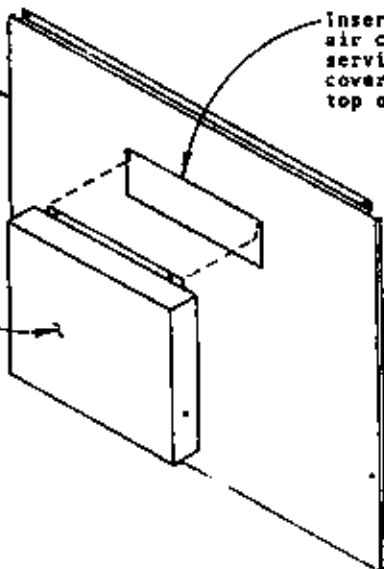

Insert top flange of fresh  
air cover into opening in  
service door and push top of  
cover assembly all the way to  
top of opening.

Service Door

Model FAD25

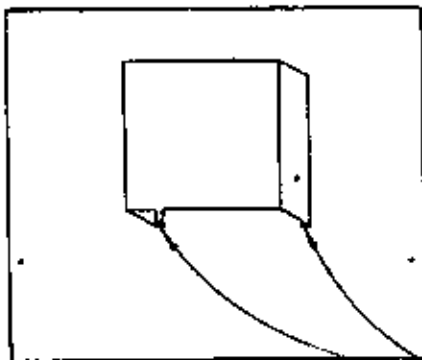
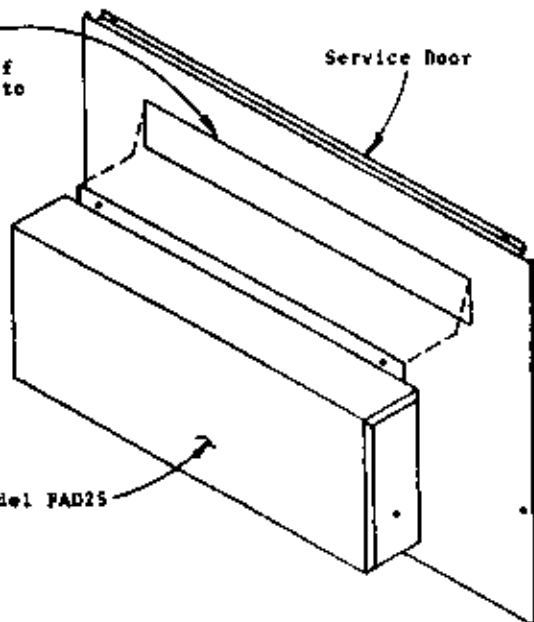

Secure bottom of  
Fresh Air Cover Assembly  
with two screws.

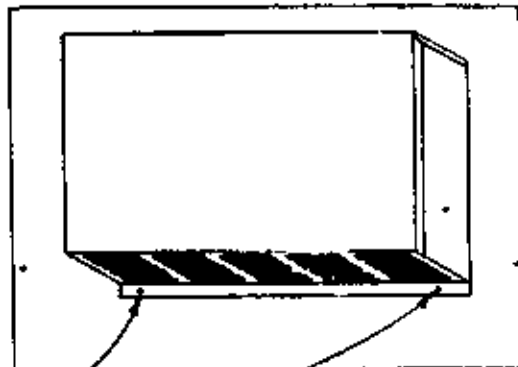
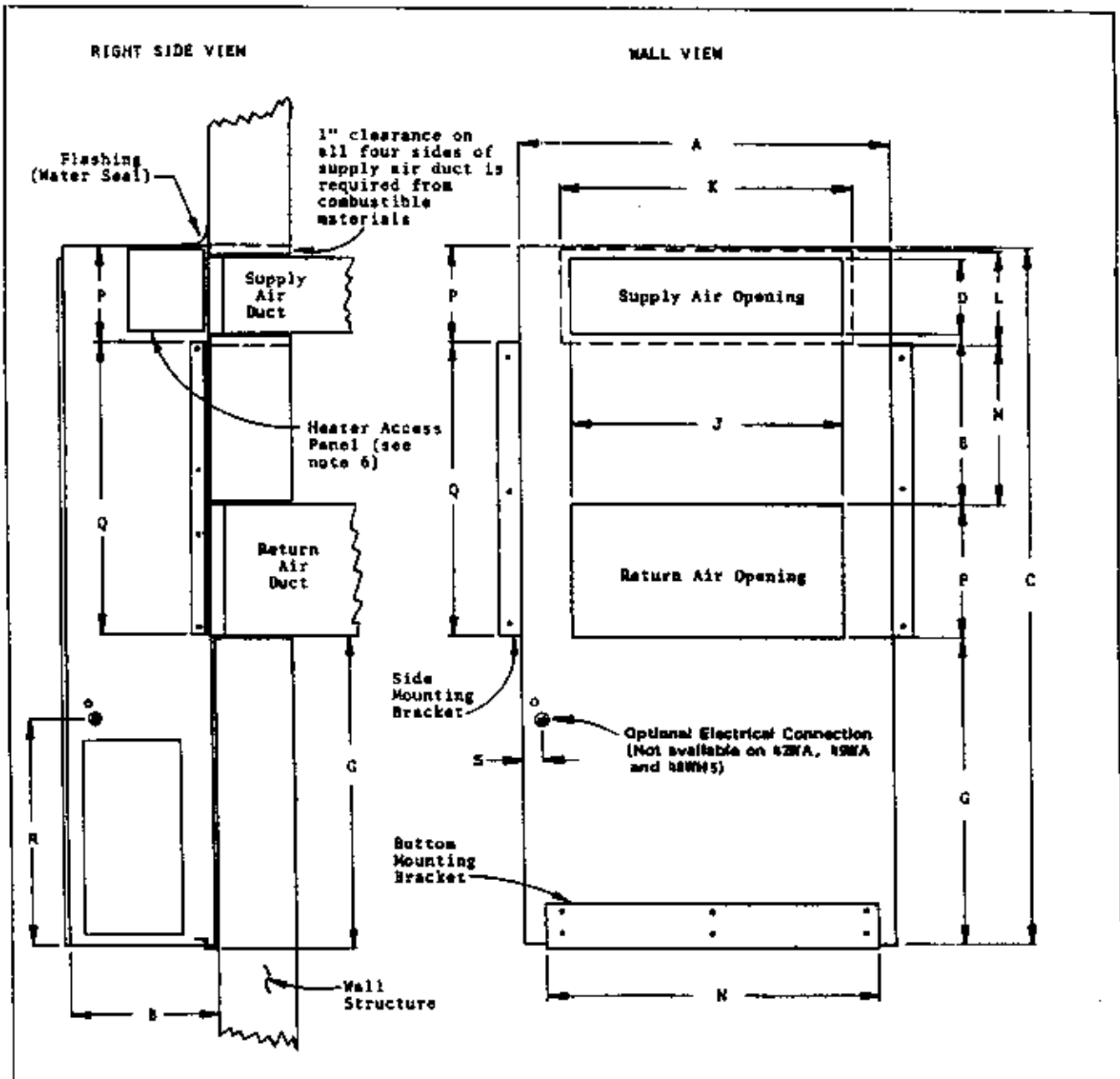

FIGURE 1

FIGURE 2



MODEL	A	B	C	D	E	F	G	J	K	L	M	N	P	Q	R	S
20WA, 24WA 18WH, 24WH	32-1/4	13-1/2	68-3/8	8	28-1/2	12	27-1/2	20	23	18	19-1/2	36	10	31	22-5/16	1-1/2
30WA, 36WA 30WH, 36WH	38-1/4	15-1/4	74	8	18	16	32-5/8	28	30	18	17	34	10	31	24-7/8	2
42WA, 48WA, 60WA 42WH, 60WH	42	22	84	10	30	16	26-5/8	30	32	12	28	34	18	42	N/A	N/A

**MOUNTING INSTRUCTIONS**

- These units are secured by wall mounting brackets which secure the unit to the outside wall surface at both sides and at the bottom.
- The unit itself is suitable for "0" inch clearance, but the supply air duct flange and the first few feet of supply air duct require 1 inch clearance to combustible material. If combustible wall, use K and L dimensions for sizing. If non-combustible, use D and J.
- After the wall opening positions have been selected, lay out the position for the bottom and side brackets. Fasten the brackets securely to the wall (type of fasteners will depend on wall construction).
- Be sure to observe the P dimension when attaching the side brackets. This will assure that no screws are driven into the unit sides damaging any internal parts. One-half inch sheet metal screws are recommended.
- For additional mounting rigidity, the return air and supply air (depending upon wall construction) frames or collars can be drilled and screwed or welded to the structural wall itself. Be sure to observe required clearance if combustible wall.
- Maintain 30 inches minimum clearance on right side of unit to allow access to heat strip.

These curves are based upon 80°DB, 67°WB R.A. Temp. rated CFM (air-flow) across the evaporator coil and should be used for reference purposes only. Special Information can be found under section titled "Refrigerant Charge" elsewhere in manual. If there is any doubt as to correct operating charge being in the system, the charge should be removed, system evacuated, and recharged according to serial plate instructions.

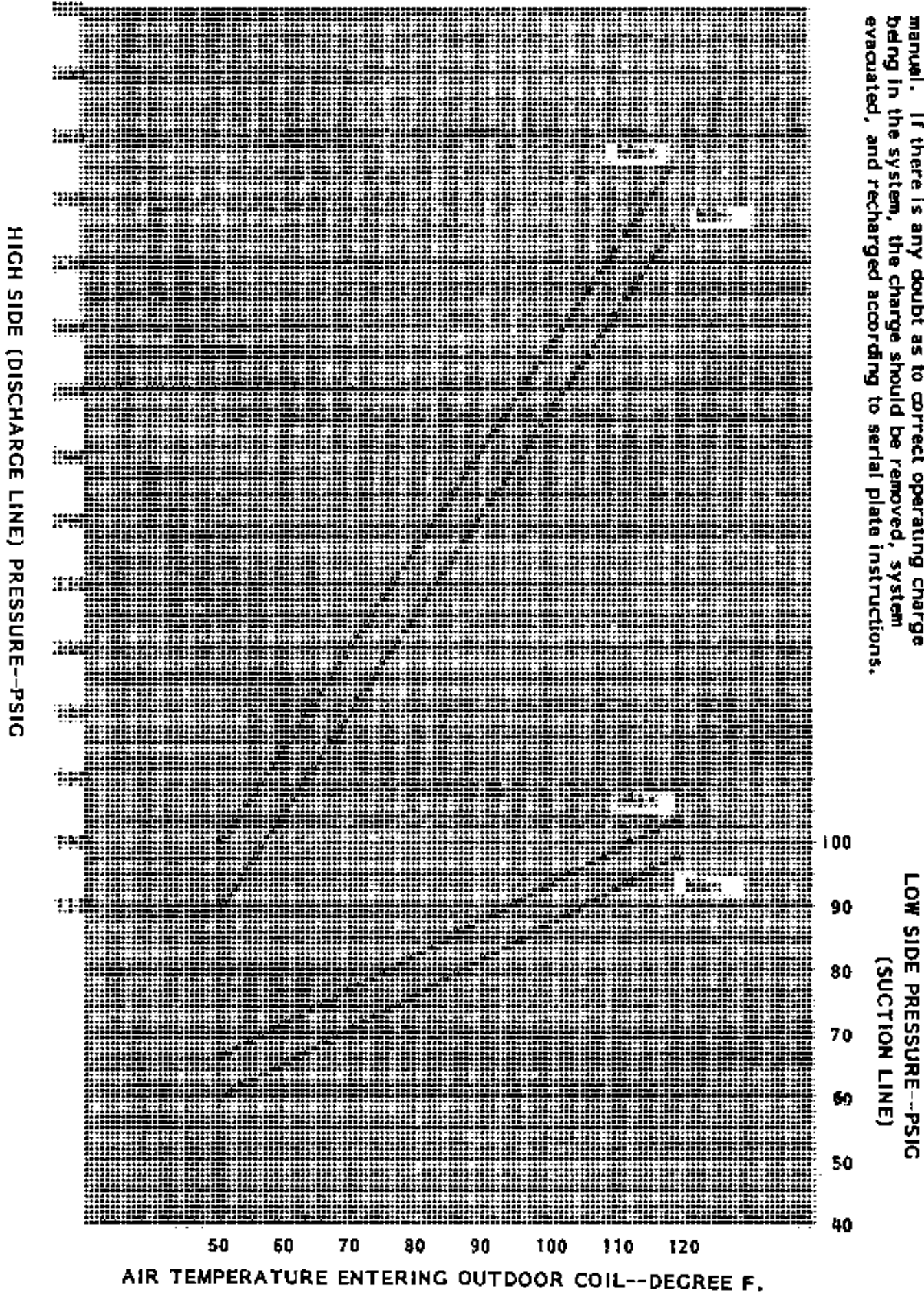

PACKAGED AIR CONDITIONER MODEL 20WAE

These curves are based upon 80°DB, 67°WB R.A. Temp. and rated CFM (airflow) across the evaporator coil and should be used for reference purposes only. Special information can be found under section titled "Refrigerant Charge" elsewhere in manual. If there is any doubt as to correct operating charge being in the system, the charge should be removed, system evacuated, and recharged according to serial plate instructions.

HIGH SIDE (DISCHARGE LINE) PRESSURE--PSIG

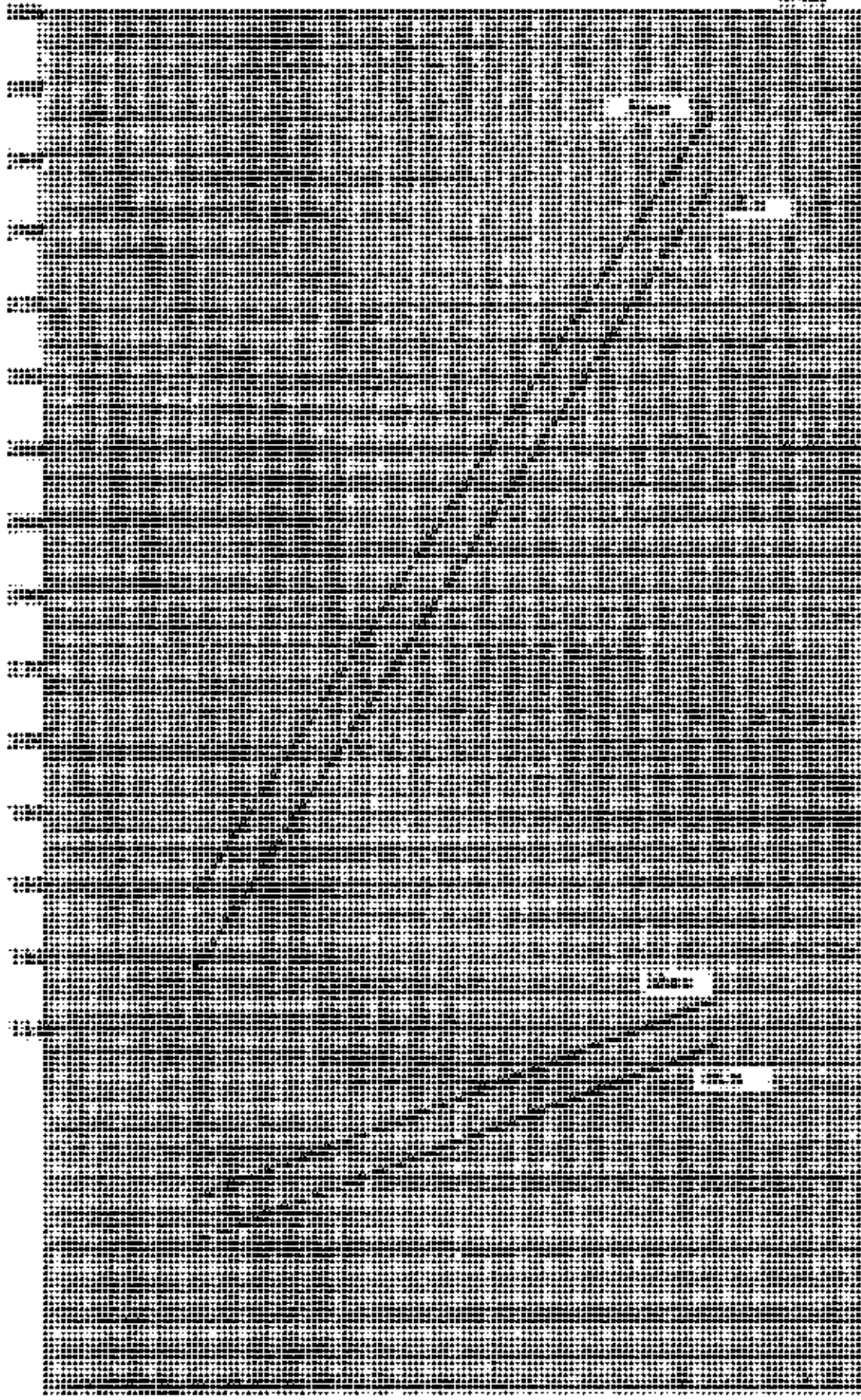

LOW SIDE PRESSURE--PSIG  
(SUCTION LINE)

50 60 70 80 90 100 110 120  
AIR TEMPERATURE ENTERING OUTDOOR COIL--DEGREE F.



**PARTS LIST**  
**SINGLE PACKAGE AIR CONDITIONERS**

3/86

PART NO.	DESCRIPTION	20WA 2	24WA 5
5152-030	Blower Housing 9-7	x	x
5152-028	Blower Wheel 9-7	x	x
5152-029	Blower Wheel 9-7	x	x
8552-045	Capacitor 30/370V	x	
8552-032	Capacitor 35/370V		x
8552-002	Capacitor 5/370V	x	x
8552-004	Capacitor 7.5/370V	x	x
5811-005	Capillary Tube - Cool	(2)	
5811-011	Capillary Tube - Cool		(2)
8000-093	Compressor H22B153ABCA	x	
8000-090	Compressor H22B233ABCA		x
5451-011	Motor Mounting Parts	x	x
5051-036	Condenser Coil		x
8401-007	Contactator - Comp. 25A	x	x
8401-006	Contactator - Heater 2P18	x	x
5060-041	Evaporator Coil	x	x
5151-033	Fan Blade F10H8.7	x	x
7004-006	Filter 18x25	x	x
8604-041	Heat Strip 4Kw	x	x
8604-042	Heat Strip 5Kw	x	x
8604-043	Heat Strip 8Kw	x	x
8604-044	Heat Strip 10Kw	x	x
8402-048	Limit Switch 160°	x	x
8102-009	Motor - Blower 1/6 hp	x	x
8103-016	Motor - Fan 1/5 hp	x	x
8200-023	Motor Mount - Fan	x	x
8201-009	Relay - Blower	x	x
8200-031	Motor Mount - Blower	x	x
5210-004	Strainer	x	x
8607-006	Terminal Board 24V	x	x
8607-013	Terminal Block 230V	x	x
8402-030	Thermal Cut-off	x	x
8407-034	Transformer 40VA	x	x

Minimum Net Billing \$15.00. Supersedes all previous lists.  
Subject to change without notice.

CIRCUIT A	
WIRING	270V/200-46-1
270V	200V
270V	200V

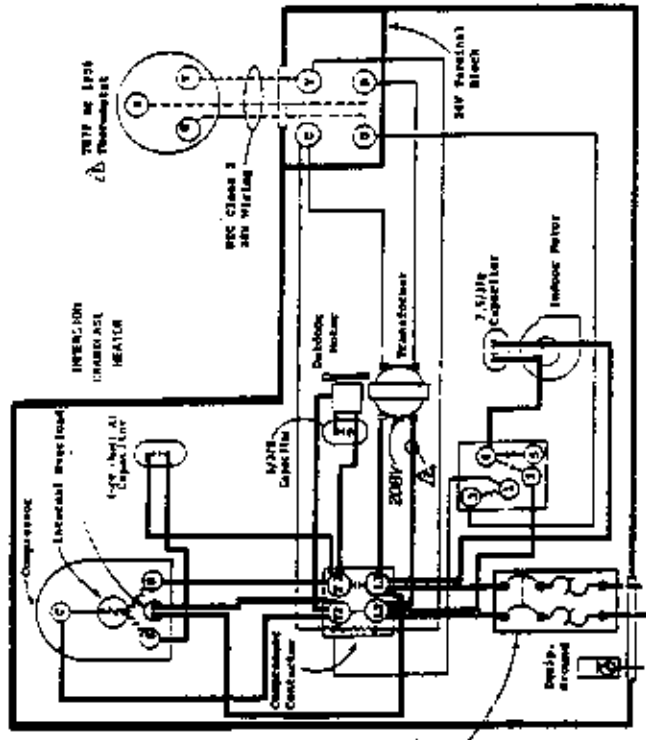

See alternate thermostat sheet.  
 For 200V operation, wires with  
 also to 200V terminal or top

WIRING	270V/200-46-1
270V	200V
270V	200V

FACTORY WIRING	
Wiring	270V/200-46-1
270V	200V
270V	200V

4002-111B

CIRCUIT A	
WIRING	270V/200-46-1
270V	200V
270V	200V

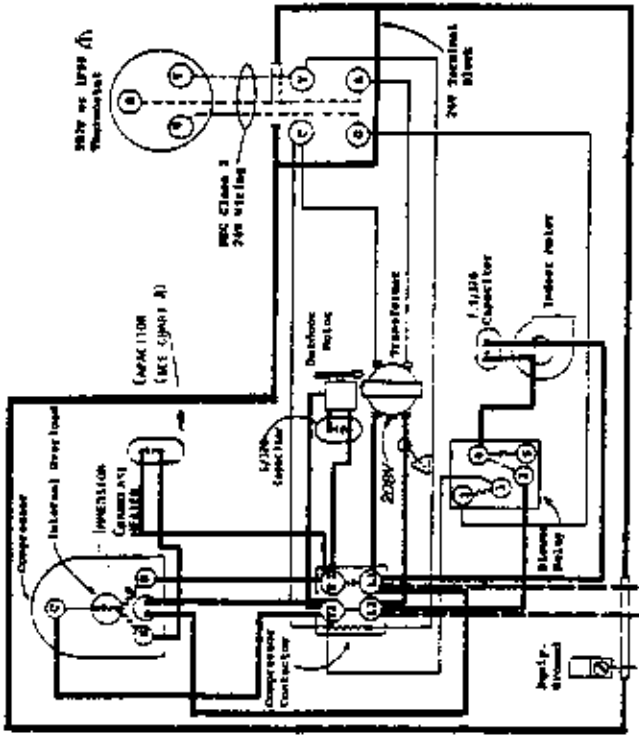

See alternate thermostat sheet.  
 For 200V operation, wires with  
 also to 200V terminal or top

WIRING	270V/200-46-1
270V	200V
270V	200V

FACTORY WIRING	
Wiring	270V/200-46-1
270V	200V
270V	200V

4002-1101

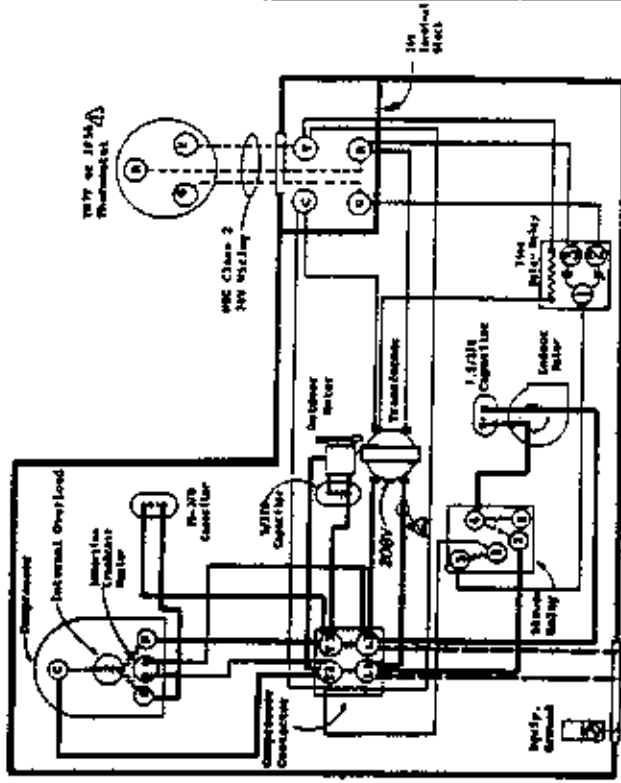

△ No alternate thermostat used.  
 △ For only operation wires (1A) use of 180° thermostat of 100.

MODEL 21000

FACTORY WIRING

Low Voltage	...
High Voltage	...

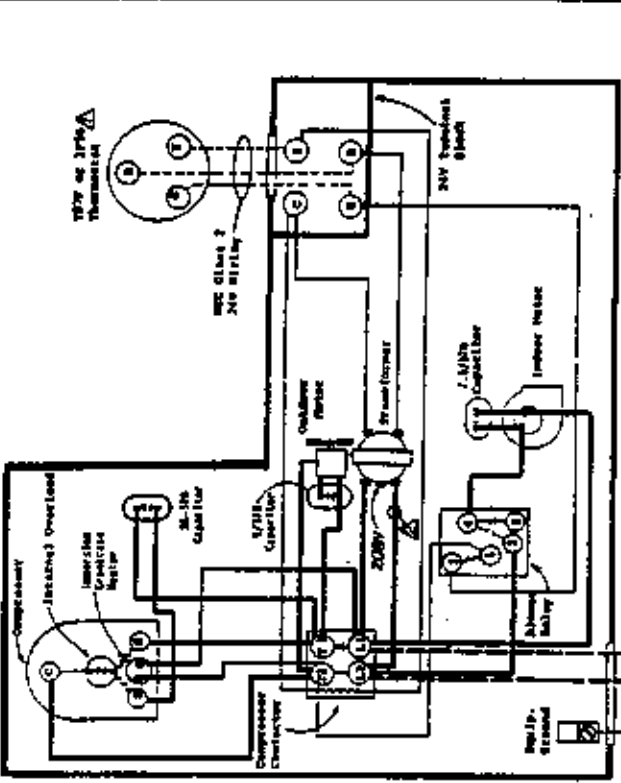

△ No alternate thermostat used.  
 △ For only operation wires (1A) use of 180° thermostat of 100.

MODEL 21000

FACTORY WIRING

Low Voltage	...
High Voltage	...

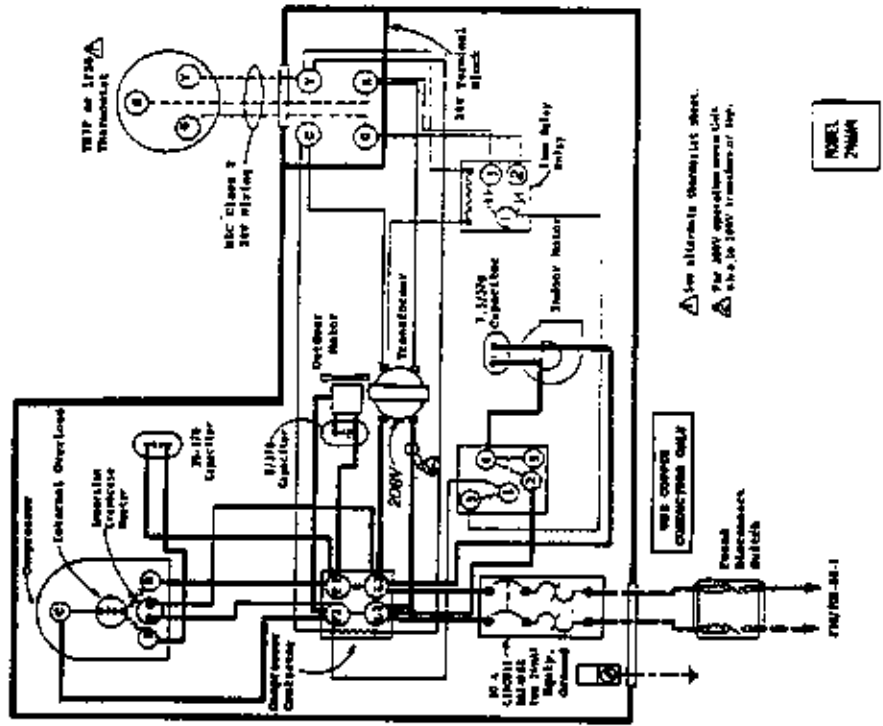

**PACKET WIRING FIELD WIRING**  
 Low Voltage \_\_\_\_\_  
 High Voltage \_\_\_\_\_

**REBEL 29434**

Use alternate thermostat sheet.  
 For 24V operation with 115V wire to 180V thermostat top.

USE COPPER CONDUCTORS ONLY

Fused Disconnect SWITCH

FRN/FR-04-1

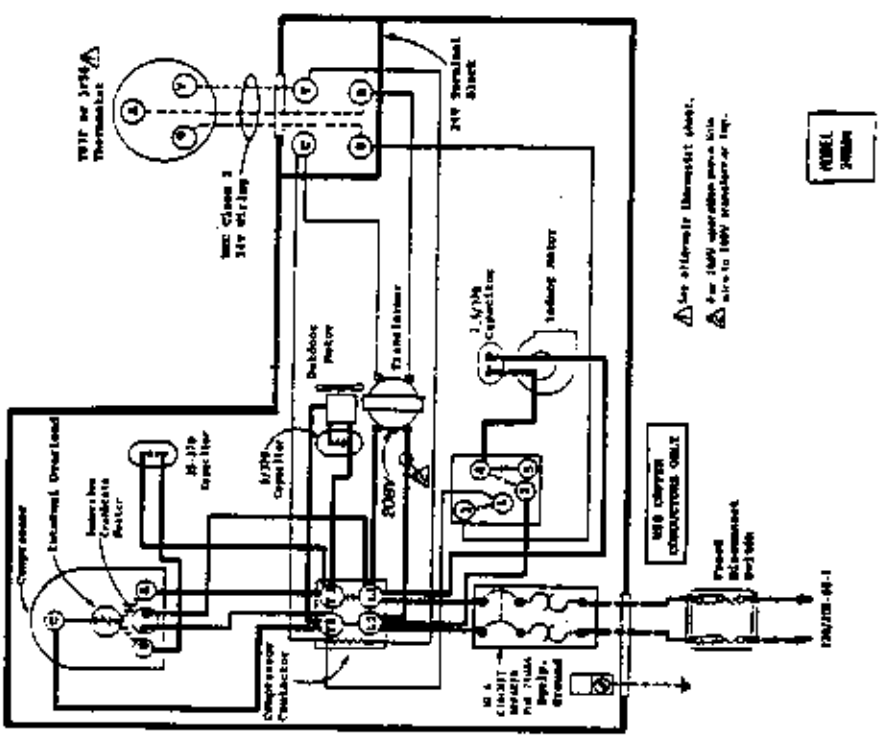

**PACKET WIRING FIELD WIRING**  
 Low Voltage \_\_\_\_\_  
 High Voltage \_\_\_\_\_

**REBEL 29434**

Use alternate thermostat sheet.  
 For 24V operation with 115V wire to 180V thermostat top.

USE COPPER CONDUCTORS ONLY

Fused Disconnect SWITCH

FRN/FR-04-1

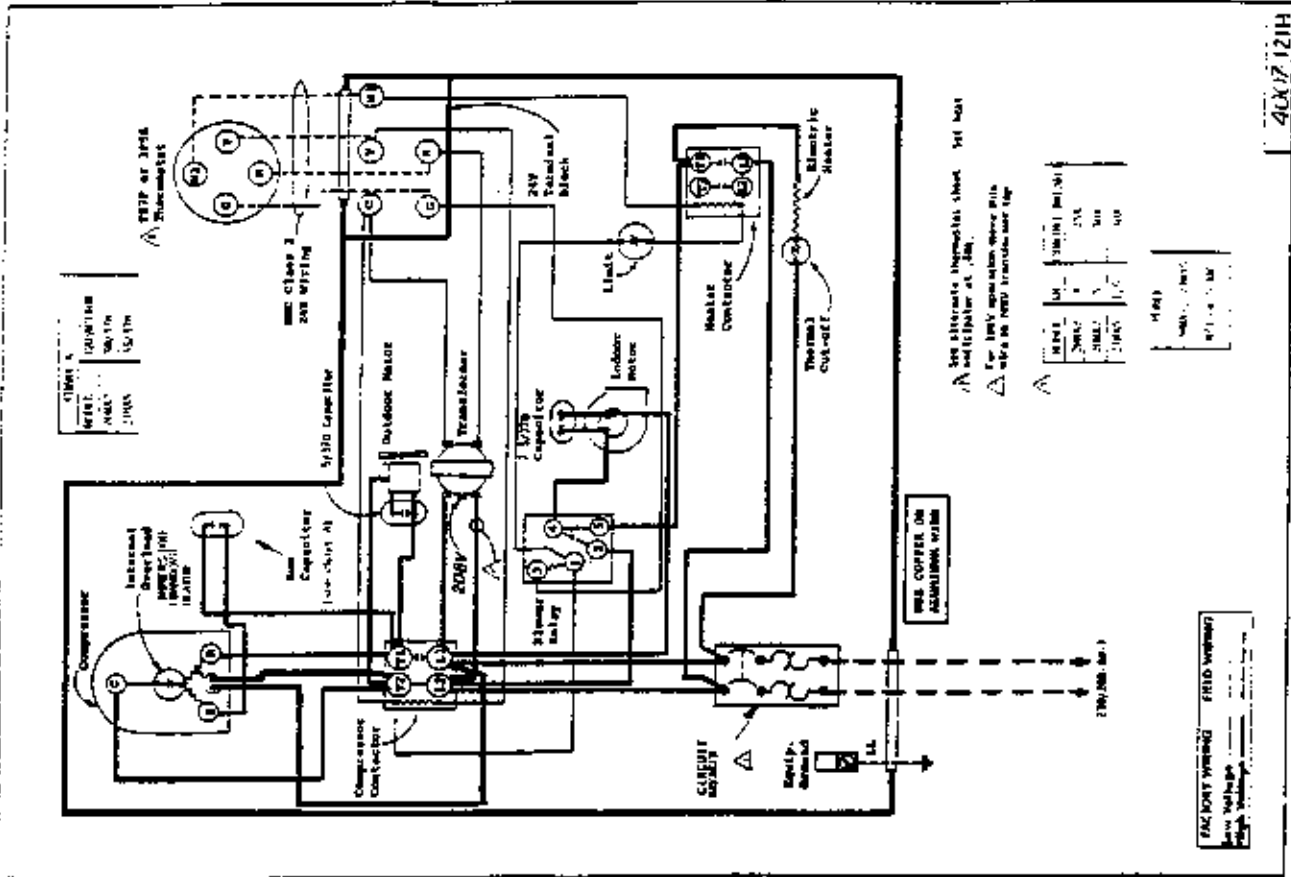
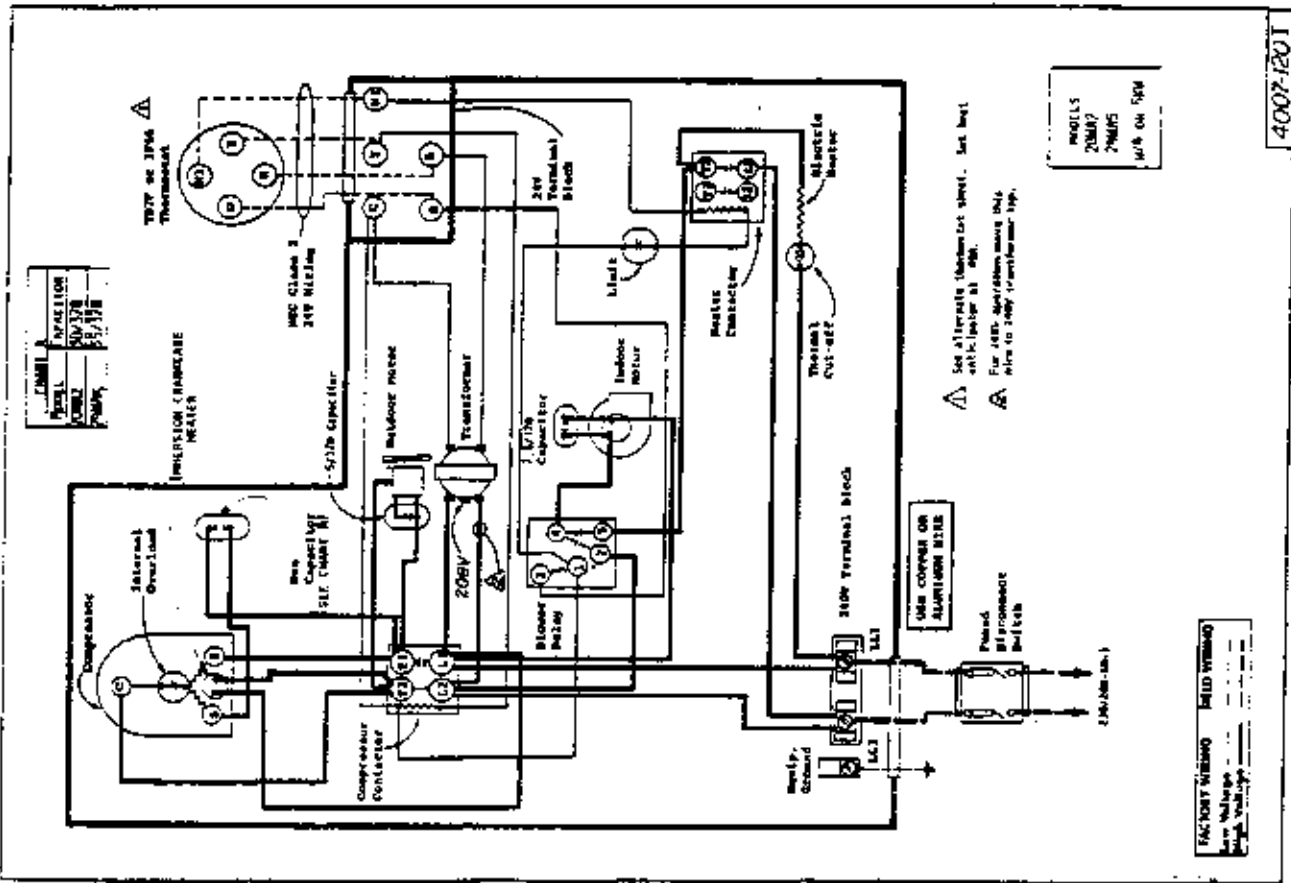



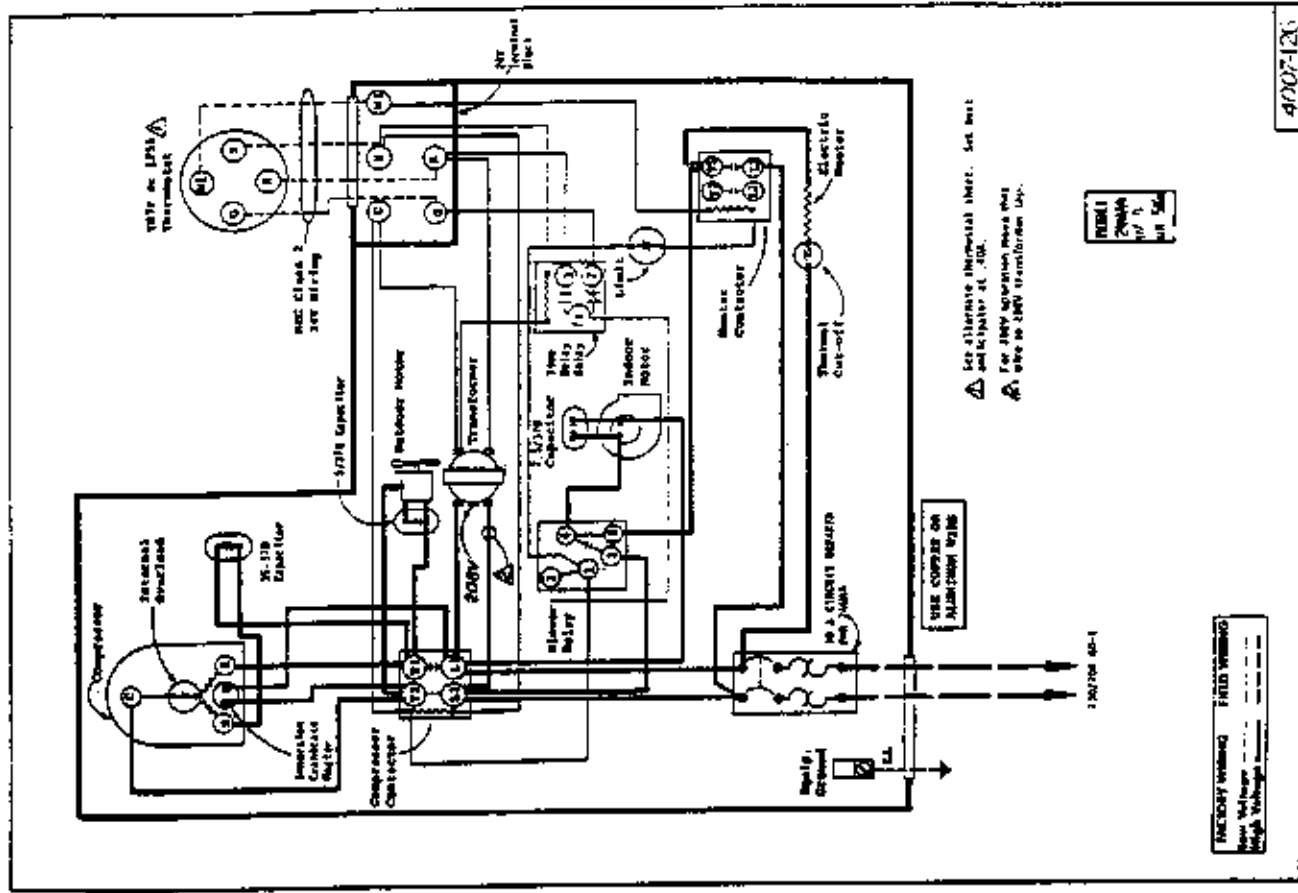
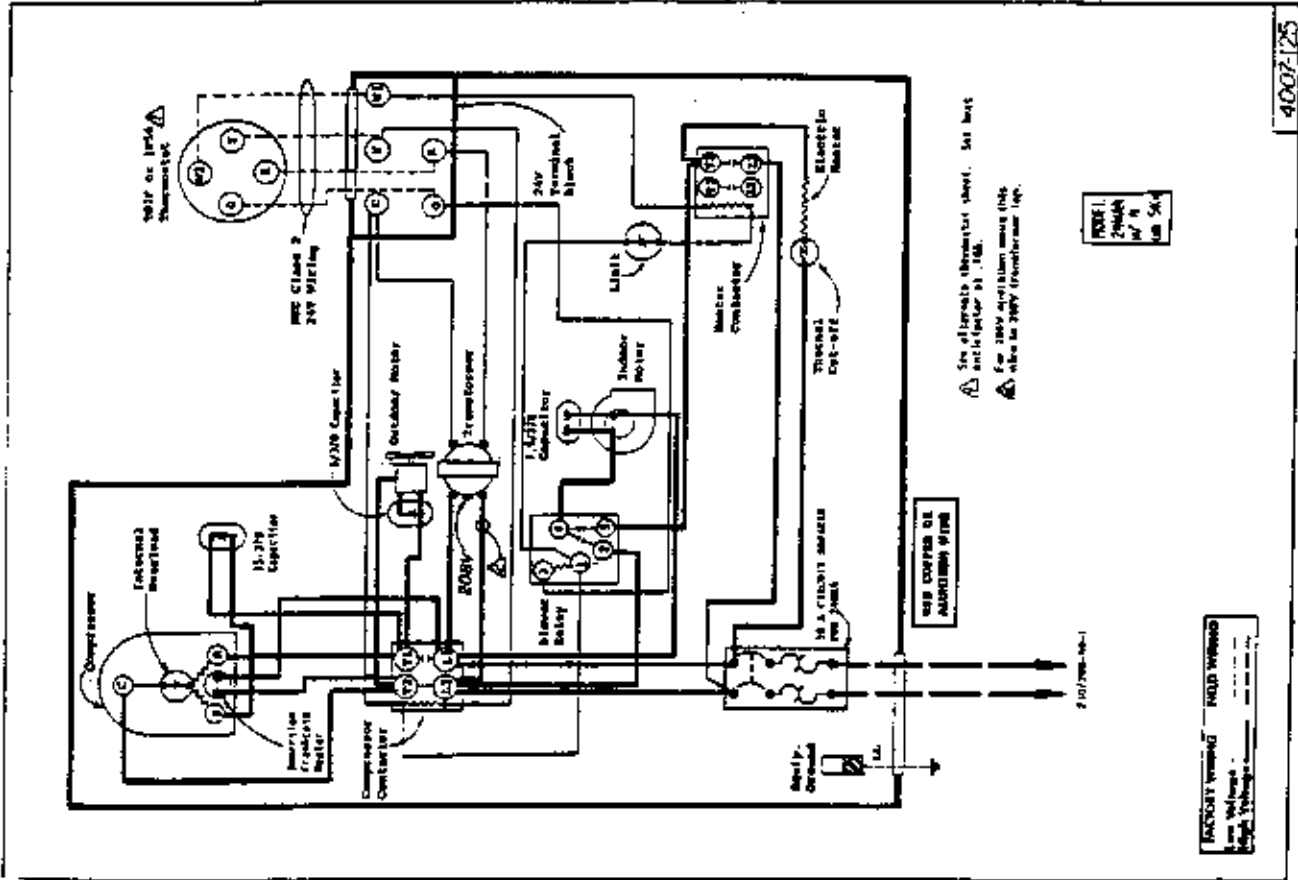

Sheet A

MODEL	2002
DATE	11/15/70
BY	WMS

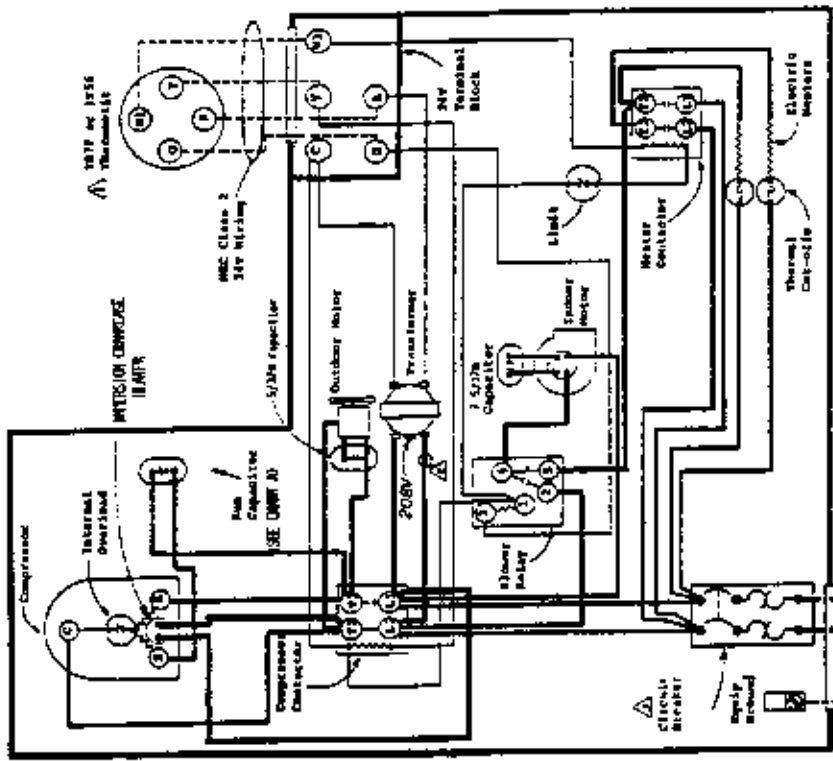

See alternate thermostat sheet. Set heat anticipator at 1/8".

For 200V operation move this wire to 200V terminals on top.

WIRE	NO.	SIZE	TYPE
200V, 200V	1	10	ET A
200V, 200V	2	10	ET A
WIRETS			
200V, 200V			
w/ 8 on 100V			

4007-131R

Sheet A

MODEL	2002
DATE	11/15/70
BY	WMS

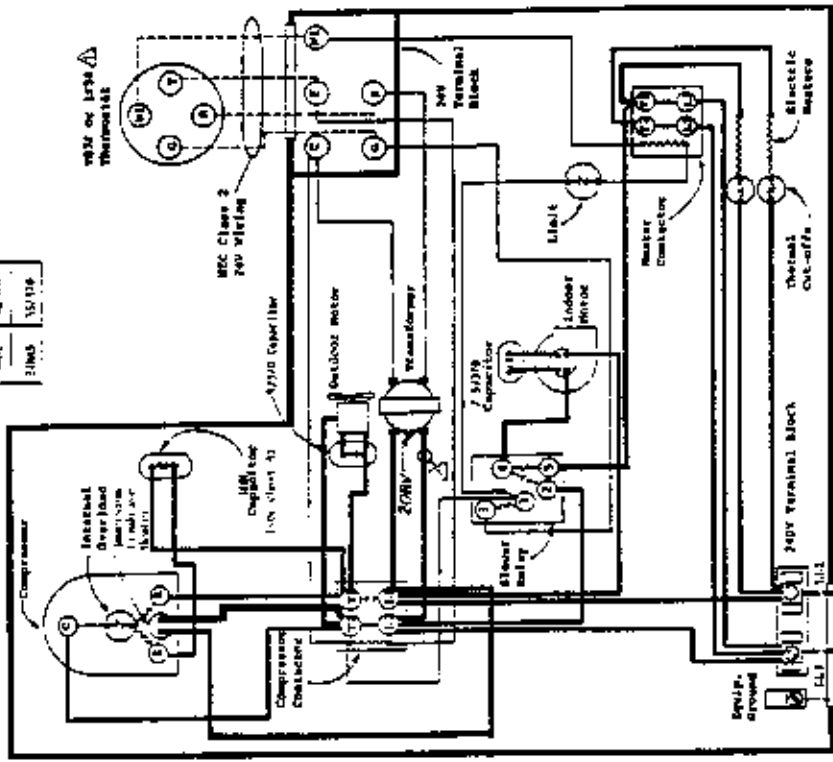

See alternate thermostat sheet. Set heat anticipator at 1/8".

For 200V operation move this wire to 200V terminals on top.

WIRE	NO.	SIZE	TYPE
200V, 200V	1	10	ET A
200V, 200V	2	10	ET A
WIRETS			
200V, 200V			
w/ 8 on 100V			

4007-131R



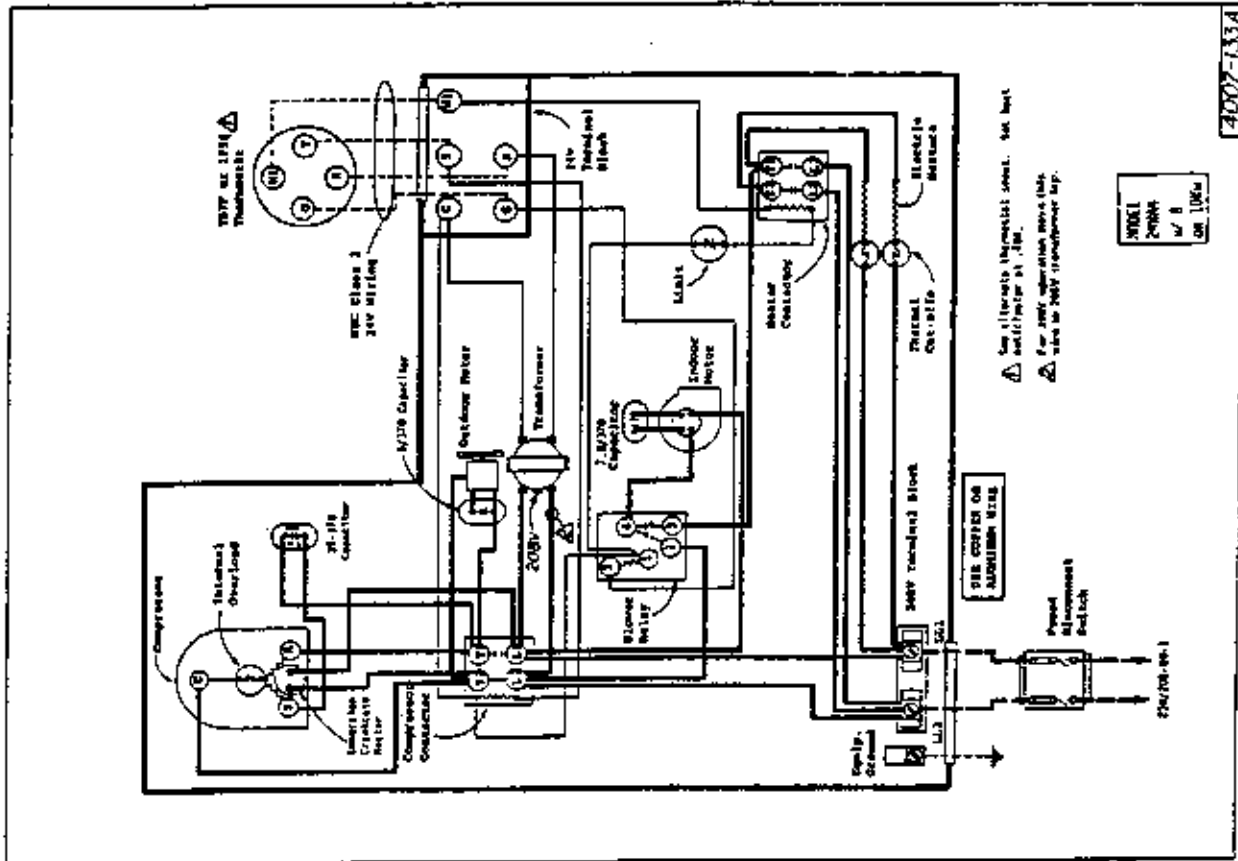

4007-133A

MODEL 2700A  
REV. 8  
ON 10/64

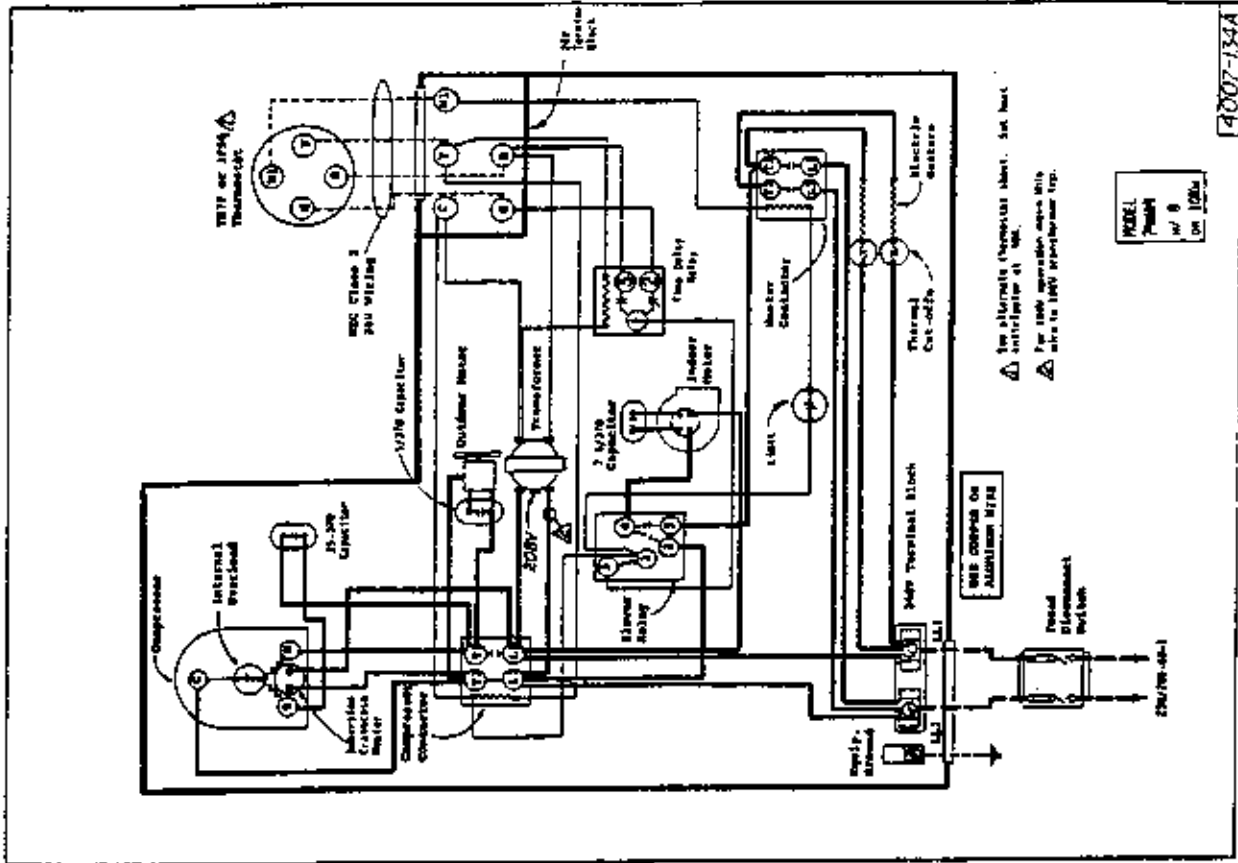

4007-133A

MODEL 2700B  
REV. 8  
ON 10/64



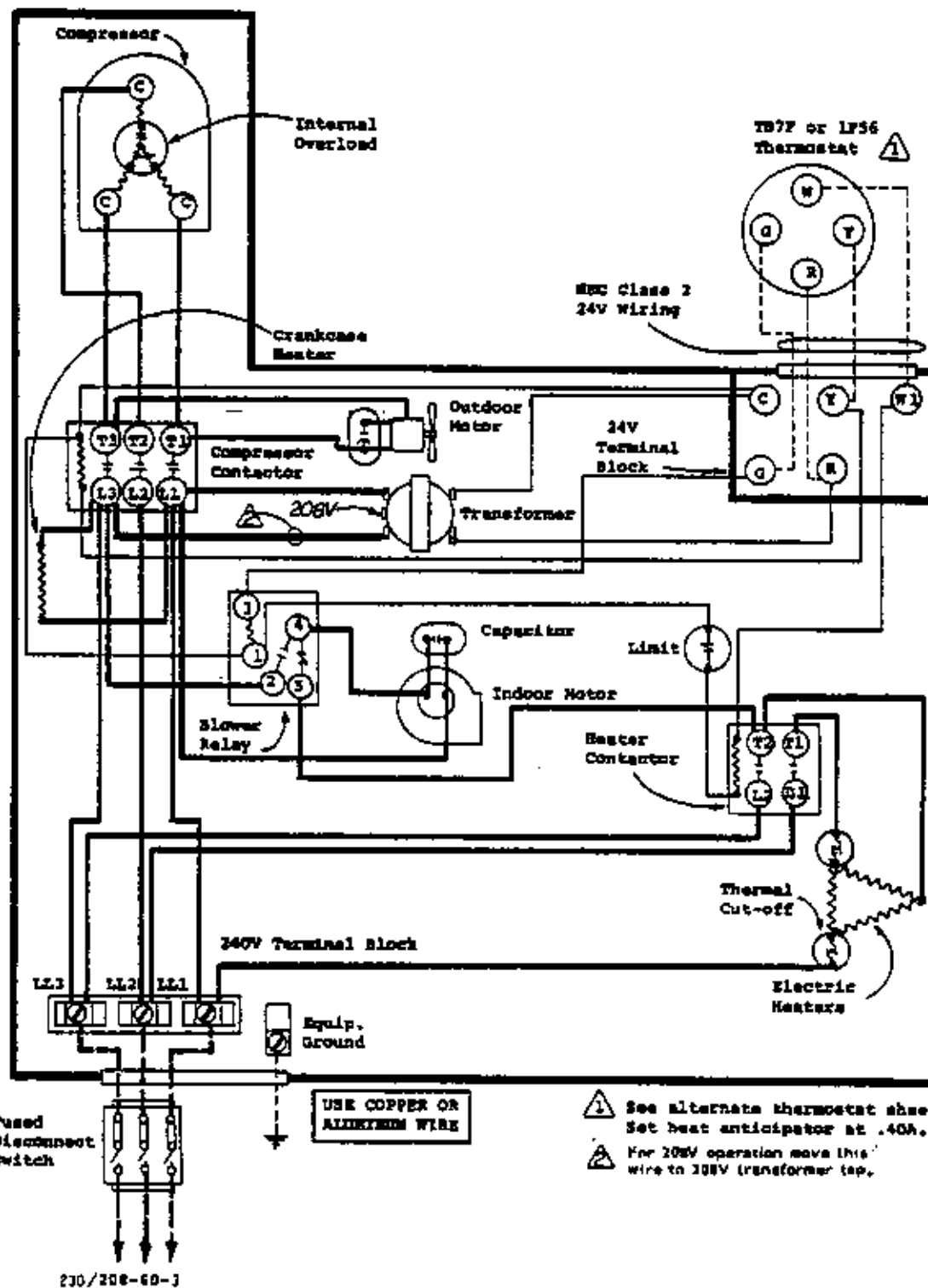

FACTORY WIRING	FIELD WIRING
Low Voltage	-----
High Voltage	-----

Model  
24W46  
w/6 or 9Rv