



CLIMATE CONTROL SOLUTIONS

Bard Manufacturing Company, Inc.
Bryan, Ohio 43506

MODEL:

**SH261D, SH311D, SH381D,
SH431D, SH491D, SH612D**

MODEL FEATURES

This model provides a unique dehumidification circuit for periods of low outdoor ambient temperature and high indoor humidity conditions. Additionally an "energy recovery ventilator" may be provided to allow for outside ventilation air requirements by eliminating excessive sensible and latent loads as a result of the increased ventilation requirement.

Refer to specification sheet S3359 for the standard features of the base unit SH models. Electrical data for the SH dehumidification models is identical to the electrical data for the standard SH models.

SPECIAL FEATURES

DEHUMIDIFICATION CIRCUIT

The dehumidification circuit incorporates an independent heat exchanger coil in the supply air stream in addition to the standard evaporator coil. This coil reheats the supply air after it passes over the cooling coil, and is sized to nominally match the sensible cooling capacity of the evaporator coil. Extended run times in dehumidification mode can be achieved using waste heat from the refrigeration cycle to achieve the reheat process, while at the same time large amounts of moisture can be extracted from the passing air stream. Models that also have electric heaters installed have the electric heat inhibited during dehumidification mode, although it remains available for additional reheat during certain conditions. See below for specific operating sequences, and see attached tables for performance on sensible and latent capacities, water removal ratings, and supply air delivery conditions.

The dehumidification refrigerant reheat circuit is controlled by a 3-way valve directing the refrigerant gas to the normal condenser during periods when standard air conditioning is required. During periods of time of low ambient temperature (approximately 65° to 75° outdoor) and high indoor humidity, a humidistat senses the need for mechanical dehumidification. It then energizes both the compressor circuit and the 3-way valve, thus directing the hot refrigerant discharge gas into a separate desuperheating condenser circuit which reheats the conditioned air before it is delivered to the room. The refrigerant gas is then routed from the desuperheating condenser to the system condenser for further heat transfer. A small capillary tube inserted between the reheat coil return line and suction line will prevent liquid from accumulating in the reheat coil when it is inactive. This drain does not affect the normal operation of the system. A check valve is located in the reheat coil return line. It has a soft spring to hold the ball on the seat. Refer to Page 2 for the location of the check valve and drain back capillary. When the humidistat is satisfied, the system automatically switches back to normal A/C mode and either continues to operate or turns off based on the signal from the wall thermostat. The result is separate humidity control at minimum operating cost.

DEHUMIDIFICATION SEQUENCE OF OPERATION

Dehumidification is controlled through a humidistat and is independent of the thermostat. On a call for dehumidification mode of operation, the compressor and 3-way valve that feeds the reheat coil are energized through circuit R-W3. Dehumidification will continue until the humidistat is satisfied.

If the room temperature falls below 1st stage heating setpoint, electric heat will be energized by the room thermostat and cycle to maintain room temperature.

If 2nd stage heating setpoint is reached, dehumidification cycle is de-energized and heat pump heating is energized.

If the mixed (return and ventilation, if used) temperature (measured at the internal filter location) drops below 65°F during dehumidification cycle, electric heat will cycle to help maintain room temperature to the 65°F condition. **Note:** On installations with ventilation package installed and controlled from the O1 terminal on Bard 24V terminal strip, this feature is inhibited anytime the O1 terminal is energized.

Anytime there is a R-Y call for cooling, dehumidification is canceled and the unit will operate in the cooling mode until satisfied. If dehumidification call is still present when cooling call is satisfied, the unit will continue to operate and revert to dehumidification mode.

**COOLING MODE
CIRCUIT DIAGRAM**

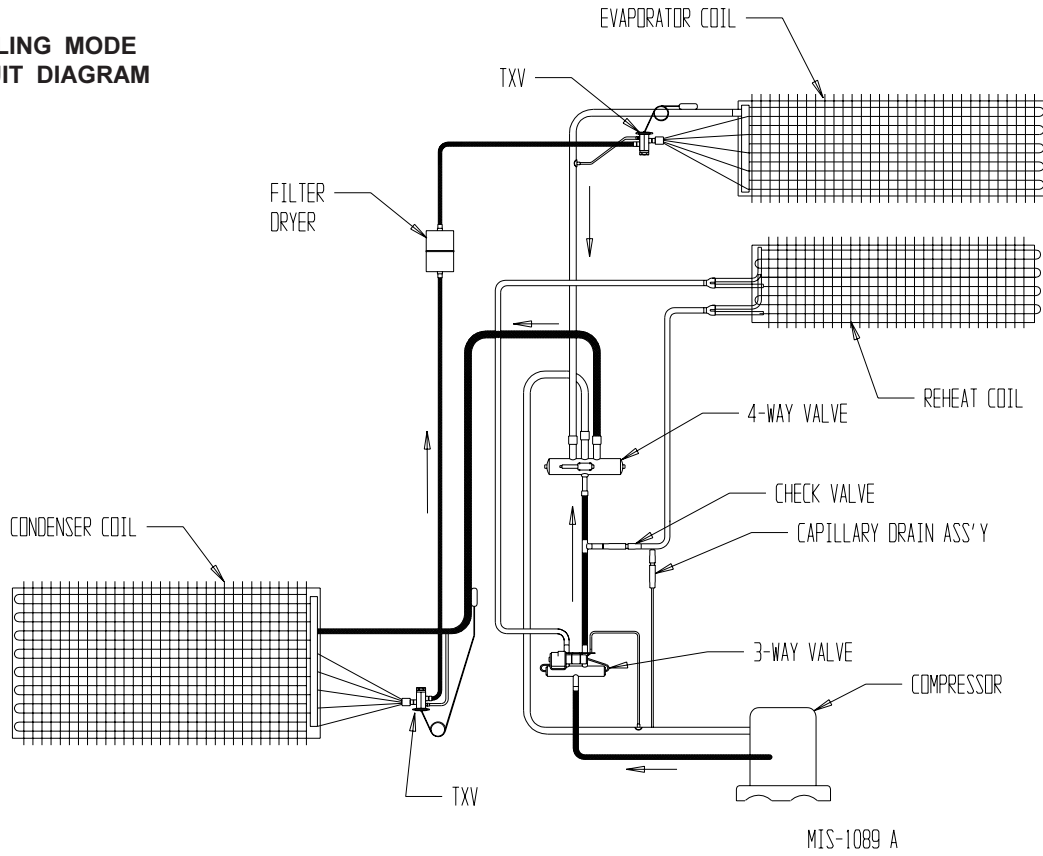

**DEHUMIDIFICATION
MODE
CIRCUIT DIAGRAM**

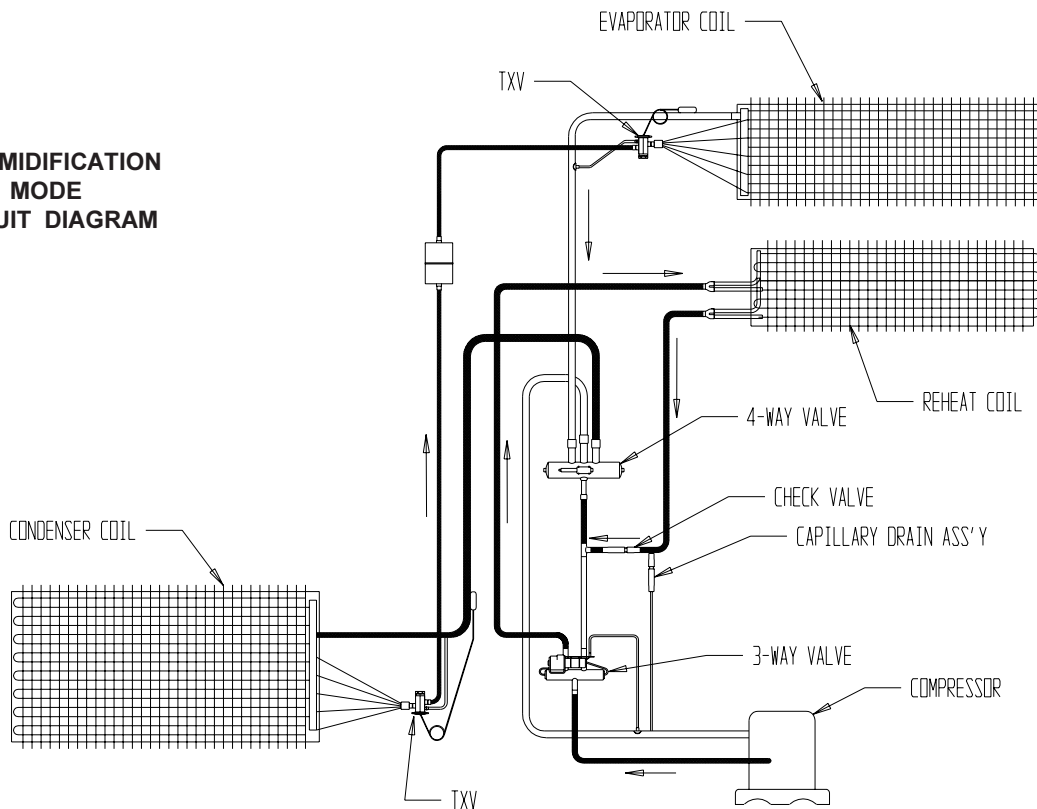

SH261D Application Performance Data										
Indoor Conditions		Outdoor Conditions	System Capacity				Pounds of Water/Hour	Evaporator Air Flow	Approximate Supply Air	Mode
DB/WB	% RH	DB	Total	Sensible	Latent	S/T	Lbs.	CFM	DB/WB	Dehum vs.A/C
65/63	90	65	13,500	-0-	13,500	-0-	12.73	800	67.1 / 58.2	Dehum
65/63	90	65	25,900	10,600	15,300	0.40	14.44	800	52.5 / 51.9	A/C
75/62.5	50	75	7,600	3,150	4,450	0.41	4.20	800	71.5 / 59.4	Dehum
75/62.5	50	75	23,700	18,300	5,400	0.77	5.10	800	54.1 / 52.0	A/C
75/65.5	60	75	7,400	1,400	7,300	0.19	6.92	800	73.4 / 61.9	Dehum
75/65.5	60	75	25,000	16,100	8,900	0.64	8.44	800	56.5 / 54.9	A/C
75/68	70	75	10,900	-0-	10,900	-0-	10.32	800	75.4 / 64.0	Dehum
75/68	70	75	26,400	14,000	12,400	0.53	11.68	800	58.9 / 57.6	A/C
80/67	50	95	5,100	-0-	5,100	-0-	4.86	800	81.9 / 65.9	Dehum
80/67	50	95	23,600	17,500	6,100	0.74	5.86	800	60.0 / 57.9	A/C

SH311D Application Performance Data										
Indoor Conditions		Outdoor Conditions	System Capacity				Pounds of Water/Hour	Evaporator Air Flow	Approximate Supply Air	Mode
DB/WB	% RH	DB	Total	Sensible	Latent	S/T	Lbs.	CFM	DB/WB	Dehum vs A/C
65/63	90	65	14,300	-0-	14,300	-0-	13.54	800	67.4 / 57.9	Dehum
65/63	90	65	29,200	11,800	17,400	0.40	16.44	800	50.9 / 50.4	A/C
75/62.5	50	75	6,100	1,800	4,300	0.29	4.06	800	72.5 / 60.1	Dehum
75/62.5	50	75	27,000	19,800	7,200	0.73	6.78	800	52.3 / 50.7	A/C
75/65.5	60	75	7,800	800	7,000	0.10	6.60	800	74.0 / 62.7	Dehum
75/65.5	60	75	28,900	17,950	10,950	0.62	10.34	800	54.9 / 53.6	A/C
75/68	70	75	10,500	-0-	10,500	-0-	9.92	800	75.2 / 64.5	Dehum
75/68	70	75	29,850	16,350	13,500	0.54	12.76	800	56.9 / 55.9	A/C
80/67	50	95	6,200	-0-	6,200	-0-	5.88	800	82.8 / 65.8	Dehum
80/67	50	95	27,000	18,600	8,400	0.68	7.02	800	58.5 / 56.7	A/C

SH381D Application Performance Data										
Indoor Conditions		Outdoor Conditions	System Capacity				Pounds of Water/Hour	Evaporator Air Flow	Approximate Supply Air	Mode
DB/WB	% RH	DB	Total	Sensible	Latent	S/T	Lbs.	CFM	DB/WB	Dehum vs A/C
65/63	90	65	21,800	-0-	21,800	-0-	20.50	1100	67.8 / 57.8	Dehum
65/63	90	65	38,550	17,550	21,000	0.55	19.90	1100	51.3 / 50.7	A/C
75/62.5	50	75	12,800	4,900	7,900	0.38	7.30	1100	70.9 / 58.7	Dehum
75/62.5	50	75	36,600	27,400	9,200	0.75	8.10	1100	52.1 / 50.9	A/C
75/65.5	60	75	14,900	2,100	12,800	0.14	12.10	1100	73.3 / 61.4	Dehum
75/65.5	60	75	38,800	24,400	14,400	0.62	15.30	1100	54.7 / 53.9	A/C
75/68	70	75	16,900	-0-	16,900	-0-	16.20	1100	75.6 / 63.4	Dehum
75/68	70	75	40,700	21,400	19,300	0.52	16.40	1100	57.0 / 56.5	A/C
80/67	50	95	8,150	-0-	8,150	-0-	7.68	1100	81.1 / 65.3	Dehum
80/67	50	95	35,500	27,000	8,500	0.76	8.60	1100	57.7 / 56.6	A/C

SH431D Application Performance Data

Indoor Conditions		Outdoor Conditions	System Capacity				Pounds of Water/Hour	Evaporator Air Flow	Approximate Supply Air	Mode
DB/WB	% RH	DB	Total	Sensible	Latent	S/T	Lbs.	CFM	DB/WB	Dehum vs A/C
65/63	90	65	24,500	-0-	24,500	-0-	23.10	1300	68.1 / 58.1	Dehum
65/63	90	65	45,500	19,100	26,400	0.42	23.50	1300	51.3 / 50.7	A/C
75/62.5	50	75	15,200	6,200	9,000	0.41	8.50	1300	70.7 / 58.8	Dehum
75/62.5	50	75	42,800	32,600	10,200	0.76	9.20	1300	51.9 / 51.1	A/C
75/65.5	60	75	18,000	2,000	16,000	0.11	15.10	1300	73.4 / 61.3	Dehum
75/65.5	60	75	45,400	28,900	16,500	0.65	15.20	1300	54.6 / 53.9	A/C
75/68	70	75	19,000	-0-	19,000	-0-	17.80	1300	75.6 / 63.5	Dehum
75/68	70	75	47,600	25,300	22,300	0.53	19.80	1300	56.9 / 56.4	A/C
80/67	50	95	9,600	-0-	9,600	-0-	9.08	1300	80.0 / 70.0	Dehum
80/67	50	95	42,000	31,200	10,800	0.74	10.20	1300	57.6 / 56.5	A/C

SH491D Application Performance Data

Indoor Conditions		Outdoor Conditions	System Capacity				Pounds of Water/Hour	Evaporator Air Flow	Approximate Supply Air	Mode
DB/WB	% RH	DB	Total	Sensible	Latent	S/T	Lbs.	CFM	DB/WB	Dehum vs A/C
65/63	90	65	24,700	-0-	24,700	-0-	23.32	1250	68.6 / 57.7	Dehum
65/63	90	65	48,750	21,050	27,700	0.43	26.12	1250	49.5 / 48.7	A/C
75/62.5	50	75	16,000	4,650	11,400	0.29	10.76	1250	71.7 / 58.5	Dehum
75/62.5	50	75	47,000	34,250	12,800	0.73	12.08	1250	49.7 / 48.8	A/C
75/65.5	60	75	20,950	-0-	20,950	-0-	19.76	1250	74.2 / 61.2	Dehum
75/65.5	60	75	49,600	30,300	19,300	0.61	18.24	1250	52.8 / 52.1	A/C
75/68	70	75	21,700	-0-	21,700	-0-	20.48	1250	76.4 / 63.3	Dehum
75/68	70	75	52,800	26,800	26,000	0.50	24.52	1250	55.3 / 54.7	A/C
80/67	50	95	12,300	-0-	12,300	-0-	11.60	1250	81.3 / 64.9	Dehum
80/67	50	95	46,500	32,400	14,100	0.70	13.15	1250	55.7 / 54.5	A/C

SH612D Application Performance Data

Indoor Conditions		Outdoor Conditions	System Capacity				Pounds of Water/Hour	Evaporator Air Flow	Approximate Supply Air	Mode
DB/WB	% RH	DB	Total	Sensible	Latent	S/T	Lbs.	CFM	DB/WB	Dehum vs A/C
65/63	90	65	31,200	-0-	31,200	-0-	31.05	1350	65.2 / 55.1	Dehum
65/63	90	65	59,600	25,800	33,800	0.43	31.43	1350	46.2 / 45.9	A/C
75/62.5	50	75	25,300	9,500	15,800	0.38	15.13	1350	68.2 / 56.0	Dehum
75/62.5	50	75	56,200	38,500	17,700	0.69	16.74	1350	47.0 / 46.0	A/C
75/65.5	60	75	29,100	4,200	24,900	0.14	21.23	1350	71.9 / 59.2	Dehum
75/65.5	60	75	61,000	34,700	26,300	0.57	23.09	1350	49.6 / 48.5	A/C
75/68	70	75	32,100	3,000	29,100	0.09	27.33	1350	72.9 / 60.6	Dehum
75/68	70	75	63,200	31,400	31,800	0.50	29.44	1350	52.2 / 51.6	A/C
80/67	50	95	19,400	3,100	16,300	0.16	16.51	1350	77.8 / 62.4	Dehum
80/67	50	95	55,900	36,500	19,400	0.65	17.65	1350	53.1 / 52.1	A/C