

⚠ DANGER

*ELECTRICAL SHOCK HAZARD
*DISCONNECT POWER BEFORE
SERVICING.

⚠ WARNING

USE COPPER CONDUCTORS
ONLY SUITABLE FOR AT LEAST
75° C.

Note: See Control Wiring Section of Installation Inst. for Wiring Energy Recovery to Unit

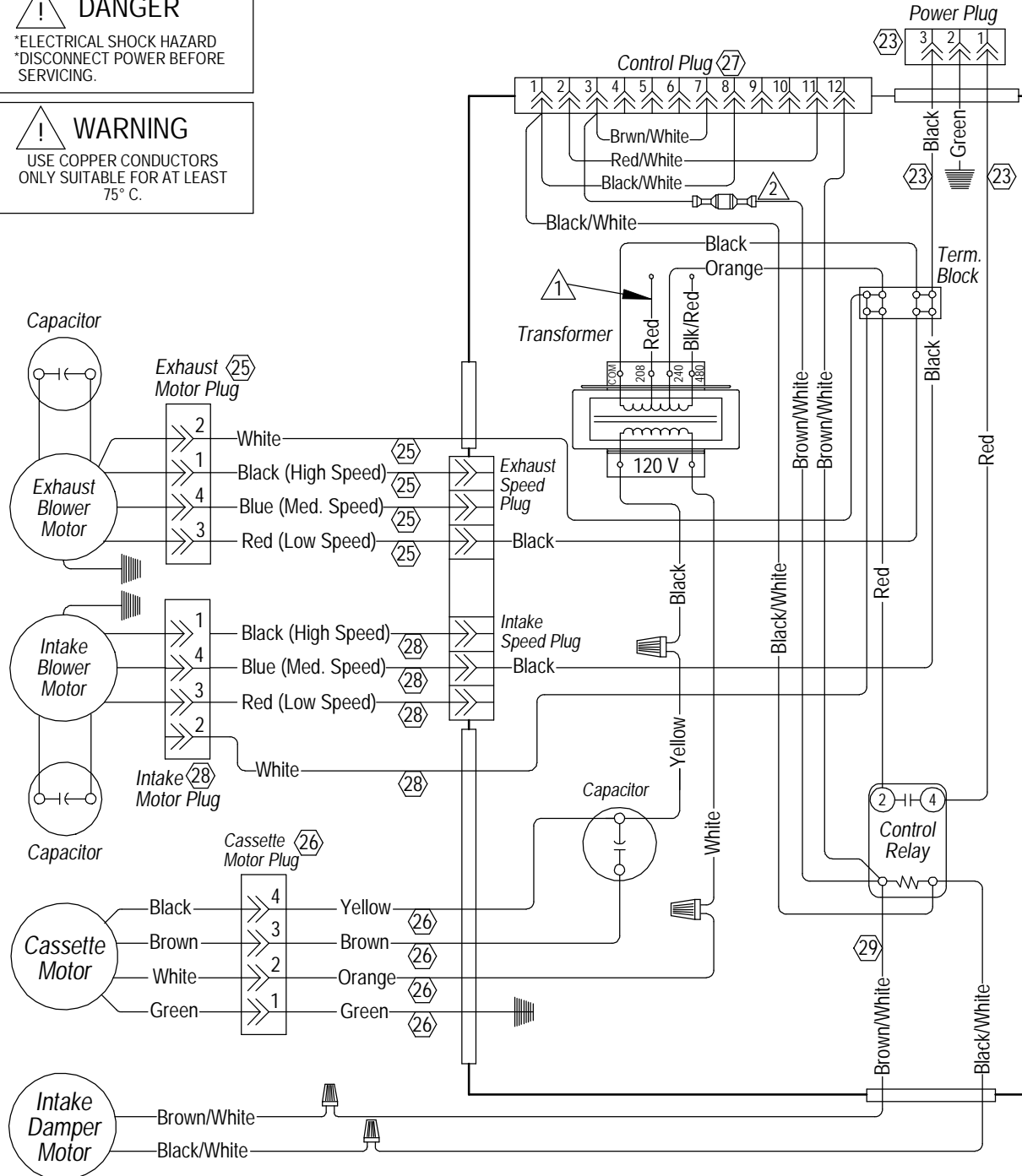

Component	Capacitor
Blower Motor	4/370
Cassette Motor	3/250

⚠ DISCONNECT ORANGE WIRE FROM
TERMINAL BLOCK AND CONNECT RED
WIRE FOR 208V OPERATION

⚠ DISCONNECT WHEN
CO2 SENSOR IS USED

To Unit High Voltage 240/208-60-1

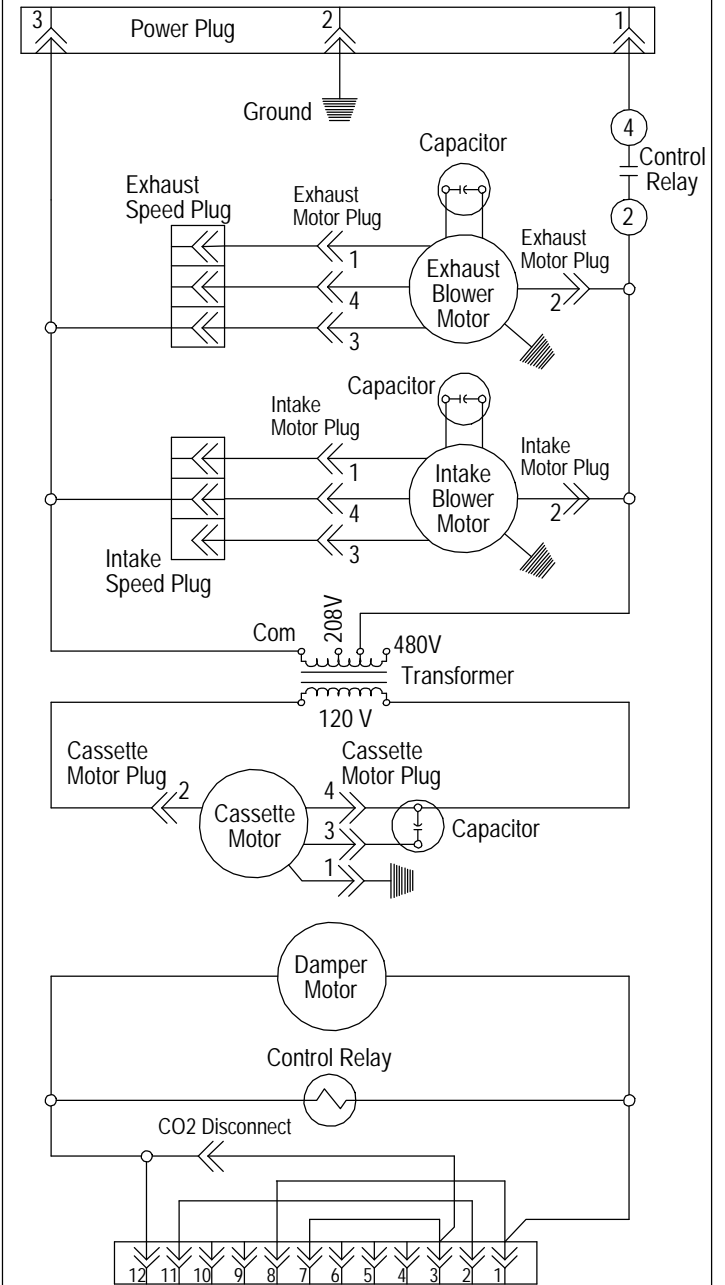

Note: See Control Wiring Section of Installation Inst.
for Wiring Energy Recovery to Unit