REPLACEMENT PARTS MANUAL

Wall Mount Variable Speed Heat Pump

Models:

W3VHY-R	W3VHYDR	W5VHY-R	W5VHYDR
W3VHY-S	W3VHYDS	W5VHY-S	W5VHYDS
W3VHY-T	W3VHYDT	W5VHY-T	W5VHYDT

Contents

Description	Page	Description	Page
External Parts – Standard		Inverter Drive Assembly – 230V 1 Phase	
♦ Exploded View	2	♦ Layout View	18
♦ Usage List	3	♦ Usage List	19
♦ Usage List	4	Inverter Drive Assembly – 230V 3 PH & 460V 3PH	
External Parts – Recessed Cabinet		♦ Layout View	20
♦ Exploded View	6	♦ Usage List	21
♦ Usage List	7		
Internal Parts – Standard & Recessed			
♦ Exploded View	8		
♦ Usage List	9		
Functional Components – Standard & Recessed			
♦ Exploded View	10		
♦ Usage List	11		
♦ Usage List	12		
Control Panel – Standard & Recessed			
♦ Layout View	14		
♦ Usage List	15		
♦ Usage List	16		
Blower Assembly			
♦ Layout View	17		
♦ Usage List	17		

General Notes

- Revised and/or additional pages may be issued from time to time.
- A complete and current manual consists of pages shown in the following contents section.

Important

- Contact the installing and/or local Bard distributor for all parts requirements. Make sure to have the complete model and serial number available from the unit rating plates.



Climate Control Solutions

Bard Manufacturing Company, Inc.
Bryan, Ohio 43506
www.bardhvac.com

Manual: 2110-1577A
Supersedes: 2110-1577
Date: 1-5-24

EXTERNAL PARTS - STANDARD

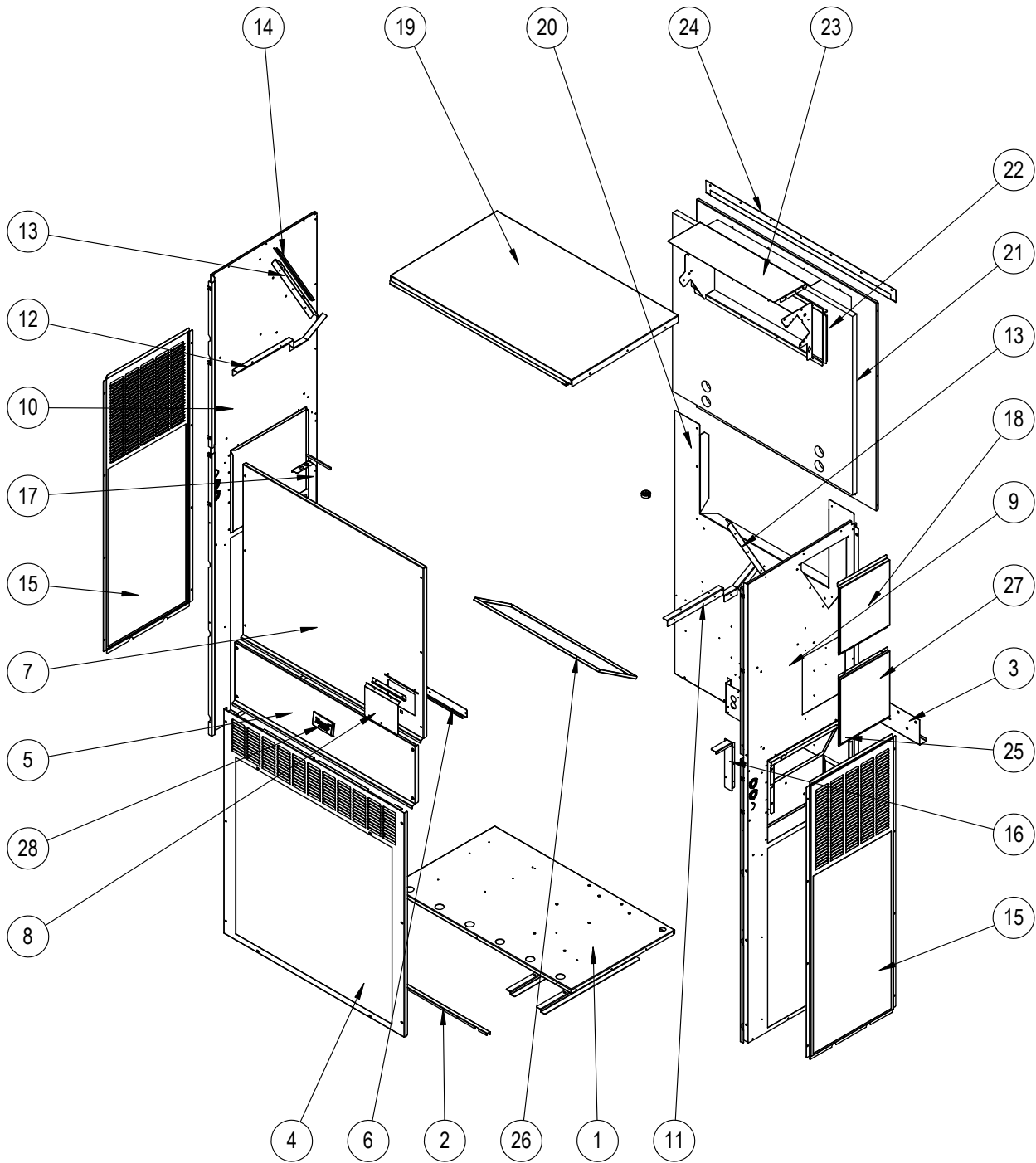

SEXP-1099

This drawing to be used for reference for pages 3 and 4

EXTERNAL PARTS - STANDARD*

Dwg No.	Part Number	Description	W3VHY-R, S, T	W3VHYDR, S, T	W5VHY-R, S, T	W5VHYDR, S, T
1	127-623BX	Base (only)	X	X	X	X
1	527-623BX	Base Assembly w/Compressor Plate	X	X	X	X
1	127-624BX ③	Base (only) - Stainless	O	O	O	O
1	527-624BX ③	Base Assembly w/Compressor Plate - Stainless	O	O	O	O
2	113-762BX	Front Base Bracket	X	X	X	X
2	113-797BX ③	Front Base Bracket - Stainless	O	O	O	O
3	113-140BX	Bottom Support Bracket	X	X	X	X
4	119-125-*BX ①	Front Grille	X	X		
4	119-148BX ②	Front Grille - Aluminum	O	O		
4	119-135BX ③	Front Grille - Stainless	O	O		
4	119-127-*BX ①	Front Grille			X	X
4	119-149BX ②	Front Grille - Aluminum			O	O
4	119-137BX ③	Front Grille - Stainless			O	O
5	533-301-*BX ①	Control Panel Cover (Outer)	X	X	X	X
5	533-309BX ②	Control Panel Cover (Outer)	O	O	O	O
5	533-310BX ③	Control Panel Cover (Outer)	O	O	O	O
6	165-608-*BX ①	Rain Channel	X	X	X	X
6	165-609BX ②	Rain Channel	O	O	O	O
6	165-610BX ③	Rain Channel	O	O	O	O
7	515-323-*BX ①	Upper Front	X	X		
7	515-328BX ②	Upper Front - Aluminum	O	O		
7	515-330BX ③	Upper Front - Stainless	O	O		
7	515-324-*BX ①	Upper Front			X	X
7	515-329BX ②	Upper Front - Aluminum			O	O
7	515-331BX ③	Upper Front - Stainless			O	O
8	153-717-*BX ①	Disconnect Access Door	X	X	X	X
8	153-723BX ②	Disconnect Access Door - Aluminum	O	O	O	O
8	153-724BX ③	Disconnect Access Door - Stainless	O	O	O	O
9	501-1133-*BX ①	Right Side Assembly	X	X		
9	501-1128BX ②	Right Side Assembly - Aluminum	O	O		
9	501-1129BX ③	Right Side Assembly - Stainless	O	O		
9	501-1135-*BX ①	Right Side Assembly			X	X
9	501-1131BX ②	Right Side Assembly - Aluminum			O	O
9	501-1132BX ③	Right Side Assembly - Stainless			O	O
10	501-1083-*BX ①	Left Side Assembly	X	X		
10	501-1073BX ②	Left Side Assembly - Aluminum	O	O		
10	501-1077BX ③	Left Side Assembly - Stainless	O	O		
10	501-1081-*BX ①	Left Side Assembly			X	X
10	501-1075BX ②	Left Side Assembly - Aluminum			O	O
10	501-1079BX ③	Left Side Assembly - Stainless			O	O
11	105X1454BX	Right Support Angle	X	X	X	X
12	105Y1454BX	Left Support Angle	X	X	X	X
13	105-1457BX	Coil Support	2	2		
13	105-1455BX	Coil Support			2	2
14	147-055BX	Coil Support Offset	X	X		
14	147-054BX	Coil Support Offset			X	X

Continued on page 4

- ① Exterior cabinet parts are manufactured with various paint color options. To ensure the proper paint color is received, include the complete model and serial number of the unit for which cabinet parts are being ordered.
- ② Exterior cabinet parts are manufactured from aluminum Code "A"
- ③ Exterior cabinet parts are manufactured from stainless steel Code "S"

X – Standard Component
O – Optional Component

EXTERNAL PARTS – STANDARD*

Dwg No.	Part Number	Description	W3VHY-R, S, T	W3VHYDR, S, T	W5VHY-R, S, T	W5VHYDR, S, T
<i>Continued from page 3</i>						
15	119-126-*BX ①	Side Grille	2	2		
15	119-142BX ②	Side Grille - Aluminum	2	2		
15	119-136BX ③	Side Grille - Stainless	2	2		
15	119-128-*BX ①	Side Grille			2	2
15	119-143BX ②	Side Grille - Aluminum			2	2
15	119-138BX ③	Side Grille - Stainless			2	2
16	105-1450BX	Right Control Panel Angle	X	X	X	X
17	105-1451BX	Left Control Panel Angle	X	X	X	X
18	543-221-*BX ①	Heater Access Cover	X	X	X	X
18	543-228BX ②	Heater Access Cover - Aluminum	0	0	0	0
18	543-229BX ③	Heater Access Cover - Stainless	0	0	0	0
19	507-382-*BX ①	Top	X	X	X	X
19	507-391BX ②	Top - Aluminum	0	0	0	0
19	507-392BX ③	Top - Stainless	0	0	0	0
20	109-412BX	Lower Back	X	X		
20	109-418BX	Lower Back	0	0		
20	109-422BX ③	Lower Back - Stainless	0	0		
20	109-414BX	Lower Back			X	X
20	109-420BX	Lower Back			0	0
20	109-424BX ③	Lower Back - Stainless			0	0
21	509-411BX	Upper Back	X	X		
21	509-417BX	Upper Back	0	0		
21	509-421BX ③	Upper Back - Stainless	0	0		
21	509-413BX	Upper Back			X	X
21	509-419BX	Upper Back			0	0
21	509-423BX ③	Upper Back - Stainless			0	0
22	111-299BX	Outlet Air Frame Assembly	X	X	X	X
23	535-129BX	Heat Shield	X	X	X	X
24	113-150-*BX ①	Top Rain Flashing	X	X	X	X
24	113-150-4BX ②	Top Rain Flashing	0	0	0	0
24	113-359BX ③	Top Rain Flashing - Stainless	0	0	0	0
25	539-406BX	Fresh Air Damper Assembly	X	X	X	X
25	543-222BX	Intake Blank-Off Plate	0	0	0	0
26	543-220BX	Exhaust Blank-Off Plate	X	X	X	X
27	543-248-*BX ①	Access Cover	X	X	X	X
27	543-250BX ②	Access Cover - Aluminum	0	0	0	0
27	543-251BX ③	Access Cover - Stainless	0	0	0	0
28	5252-033BX	Bard Nameplate	X	X	X	X

NS = Not Shown

X – Standard Component
 0 – Optional Component

- ① Exterior cabinet parts are manufactured with various paint color options. To ensure the proper paint color is received, include the complete model and serial number of the unit for which cabinet parts are being ordered.
- ② Exterior cabinet parts are manufactured from aluminum Code "A"
NOTE: #24 - Top rain flashing not available in aluminum; order 113-150-4 (Buckeye Gray).
- ③ Exterior cabinet parts are manufactured from stainless steel Code "S"

Refer to drawing on page 2

This page intentionally left blank

EXTERNAL PARTS - RECESSED CABINET

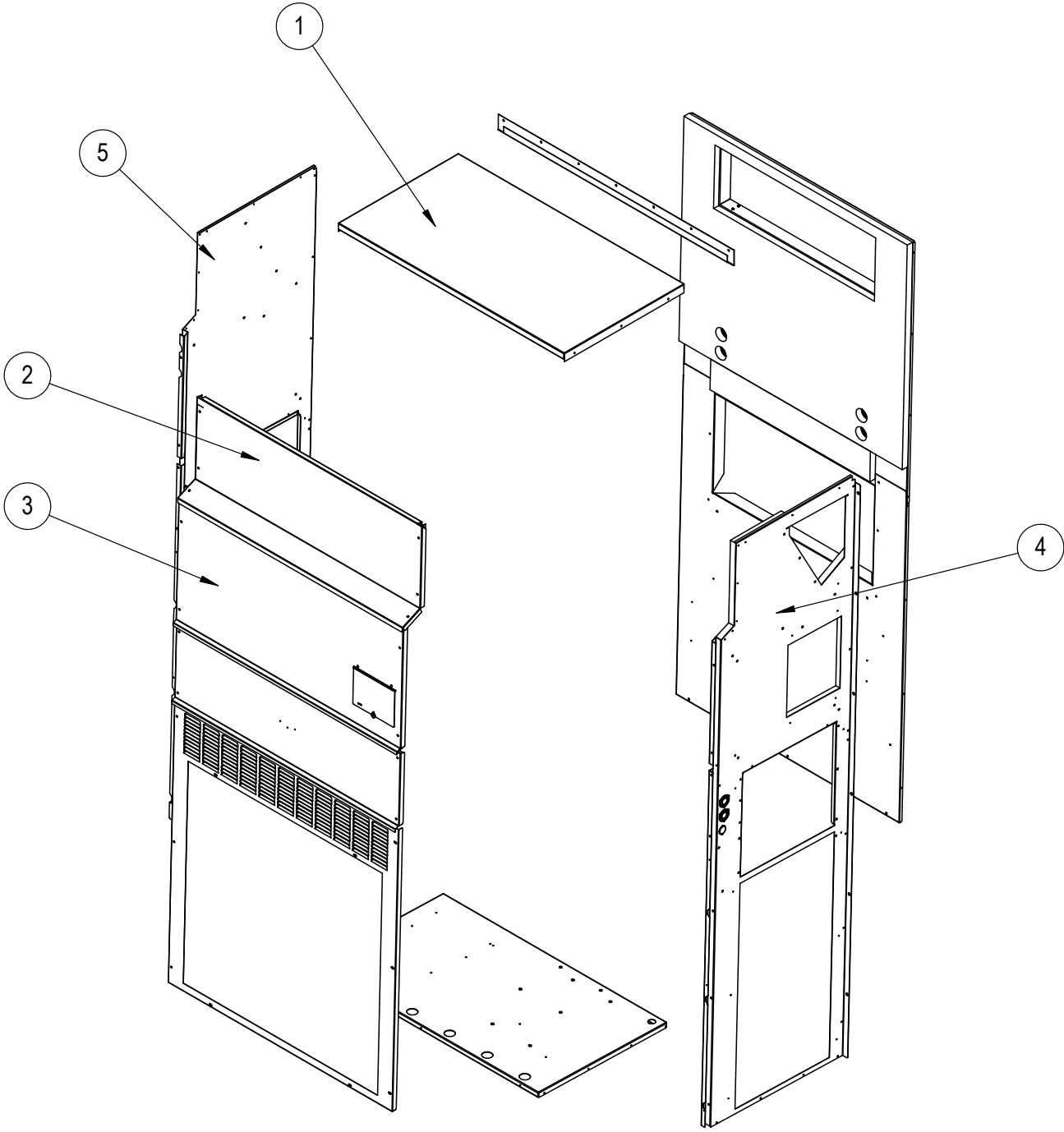

SEXP-1088

EXTERNAL PARTS – RECESSED CABINET*

Drawing No.	Part Number	Description	W3VHY-R, S, T	W3VHYDR, S, T	W5VHY-R, S, T	W5VHYDR, S, T
1	507-413-*BX ①	Top	X	X	X	X
2	515-354-*BX ①	Upper Front	X	X		
2	515-356-*BX ①	Upper Front			X	X
3	515-355-*BX ①	Center Front	X	X		
3	515-357-*BX ①	Center Front			X	X
4	501-1169-*BX ①	Right Side Assembly	X	X		
4	501-1170-*BX ①	Right Side Assembly			X	X
5	501-1171-*BX ①	Left Side Assembly	X	X		
5	501-1172-*BX ①	Left Side Assembly			X	X

① Exterior cabinet parts are manufactured with various paint color options. To ensure the proper paint color is received, include the complete model and serial number of the unit for which cabinet parts are being ordered.

* The replacement cabinet parts listed above are specific to the recessed unit W3/5VHY heat pump models (model nomenclature character 11 J or N). All other replacement cabinet external parts for these models are referenced on pages 2, 3 and 4. See **IMPORTANT** on page 3.

INTERNAL PARTS - STANDARD & RECESSED

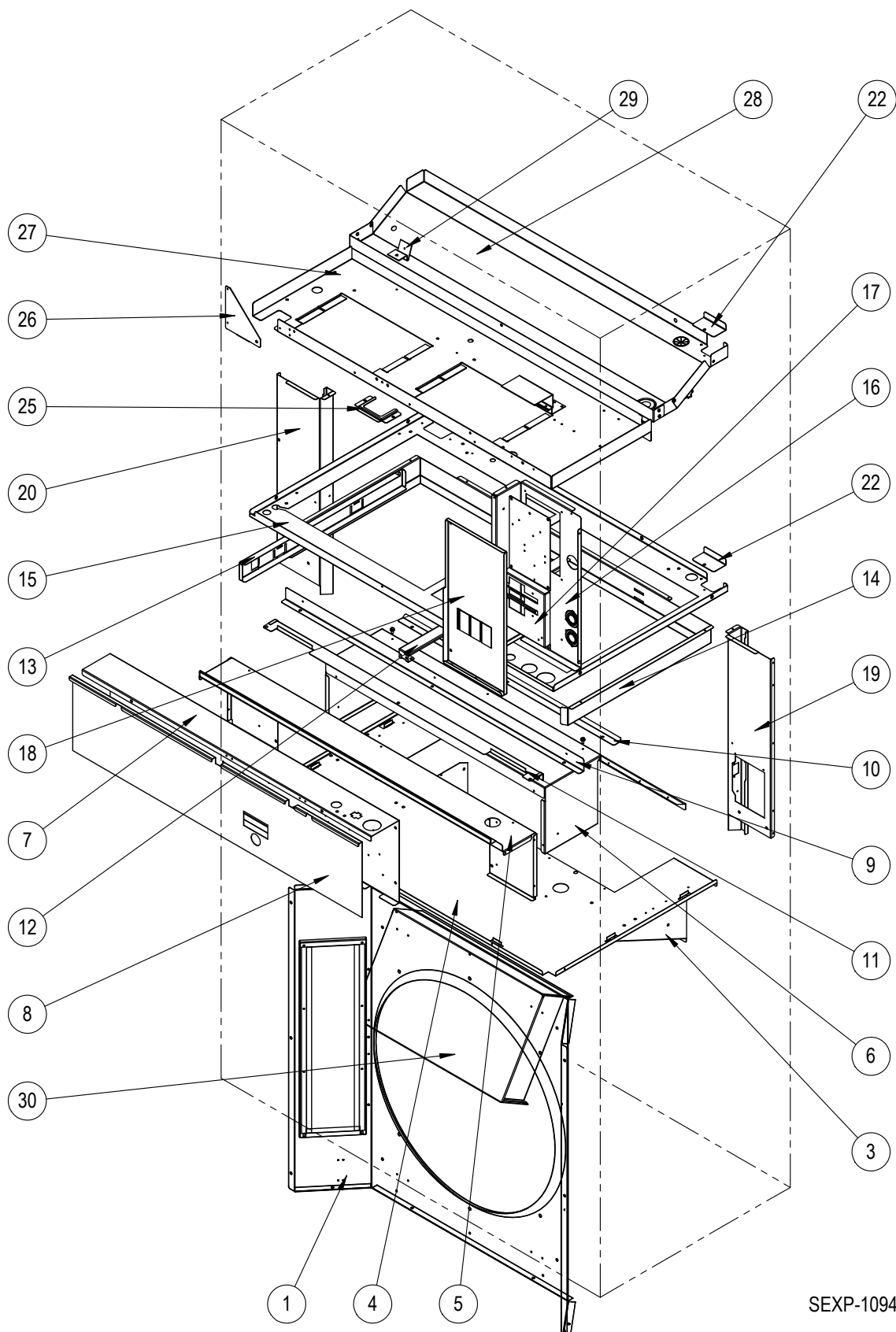

SEXP-1094

INTERNAL PARTS - STANDARD & RECESSED

Dwg. No.	Part Number	Description	W3VHY-R	W3VHY-S	W3VHY-T	W3VHYDR	W3VHYDS	W3VHYDT	W5VHY-R	W5VHY-S	W5VHY-T	W5VHYDR	W5VHYDS	W5VHYDT
1	921-0122BX	Fan Shroud - Blow Thru	X	X	X	X	X	X						
1	921-0123BX	Fan Shroud - Blow Thru							X	X	X	X	X	X
1	921-0120BX ①	Fan Shroud - Draw Thru	0	0	0	0	0	0						
1	921-0121BX ①	Fan Shroud - Draw Thru							0	0	0	0	0	0
1	921-0126BX ①②	Fan Shroud - Blow Thru - Stainless	0	0	0	0	0	0						
1	921-0127BX ①②	Fan Shroud - Blow Thru - Stainless							0	0	0	0	0	0
1	921-0124BX ①②	Fan Shroud - Draw Thru - Stainless	0	0	0	0	0	0						
1	921-0125BX ①②	Fan Shroud - Draw Thru - Stainless							0	0	0	0	0	0
3	121-586BX	Condenser Partition Insert	X	X	X	X	X	X	X	X	X	X	X	X
3	121-600BX ②	Condenser Partition Insert - Stainless	0	0	0	0	0	0	0	0	0	0	0	0
4	121-585BX	Condenser Partition	X	X	X	X	X	X	X	X	X	X	X	X
4	121-599BX ②	Condenser Partition - Stainless	0	0	0	0	0	0	0	0	0	0	0	0
5	521-630BX	Front Exhaust Partition	X	X	X	X	X	X	X	X	X	X	X	X
6	521-587BX	Exhaust Partition	X	X	X	X	X	X	X	X	X	X	X	X
7	Control Panel Assy.	See Control Panel on pages 14 – 16	X	X	X	X	X	X	X	X	X	X	X	X
8	133-356BX	Control Panel Cover (Inner)	X	X	X	X	X	X	X	X	X	X	X	X
9	105-1453BX	Front Vent Guide Rail	X	X	X	X	X	X	X	X	X	X	X	X
10	105-1452BX	Vent Guide Rail	X	X	X	X	X	X	X	X	X	X	X	X
11	135-424BX	Field Wire Shield	X	X	X	X	X	X	X	X	X	X	X	X
12	131-168BX	Filter Support Bracket	X	X	X	X	X	X	X	X	X	X	X	X
13	131-170BX	Filter Slide	X	X	X	X	X	X	X	X	X	X	X	X
14	131-169BX	Filter Rack Frame	X	X	X	X	X	X	X	X	X	X	X	X
15	121-583BX	Filter Partition	X	X	X	X	X	X	X	X	X	X	X	X
16	117-412BX	Upper Control Panel	X	X	X	X	X	X	X	X	X	X	X	X
17	127-575BX	Circuit Breaker Base	X	X		X	X		X	X		X	X	
17	127-585BX	Circuit Breaker Base - 460V			X			X			X			X
18	133-303BX	Upper Control Panel Cover	X	X		X	X		X	X		X	X	
18	133-304BX	Upper Control Panel Cover			X			X			X			X
19	135X422BX	Right Copper Chase	X	X	X	X	X	X	X	X	X	X	X	X
19	135X423BX ②	Right Copper Chase - Stainless	0	0	0	0	0	0	0	0	0	0	0	0
20	135Y393BX	Left Copper Chase	X	X	X	X	X	X	X	X	X	X	X	X
20	135-398BX ②	Left Copper Chase - Stainless	0	0	0	0	0	0	0	0	0	0	0	0
22	137-920BX	Copper Fill Plate	2	2	2	2	2	2	2	2	2	2	2	2
25	113-765BX	Grommet Retainer Bracket	X	X	X	X	X	X	X	X	X	X	X	X
26	141-492BX	Blower Partition Support	X	X	X	X	X	X	X	X	X	X	X	X
27	121-582BX	Blower Partition	X	X	X	X	X	X	X	X	X	X	X	X
28	523-161BX	Drain Pan Assembly	X	X	X	X	X	X	X	X	X	X	X	X
28	523-162BX ②③	Drain Pan Assembly - Stainless	0	0	0	0	0	0	0	0	0	0	0	0
29	113-768BX	TXV Bracket	X	X	X	X	X	X	X	X	X	X	X	X
30	Inverter Assy.	See Inverter Drive Assembly Drawing and Parts List	X	X	X	X	X	X	X	X	X	X	X	X

NS = Not Shown

- ① Fan assemblies offered in blow thru or draw thru. Refer to nomenclature character 11 X, D, J or N.
- ② Used with stainless steel cabinet option.
- ③ For aluminum units, order 523-162 stainless steel drain pan.

X – Standard Component
O – Optional Component

FUNCTIONAL COMPONENTS – STANDARD & RECESSED

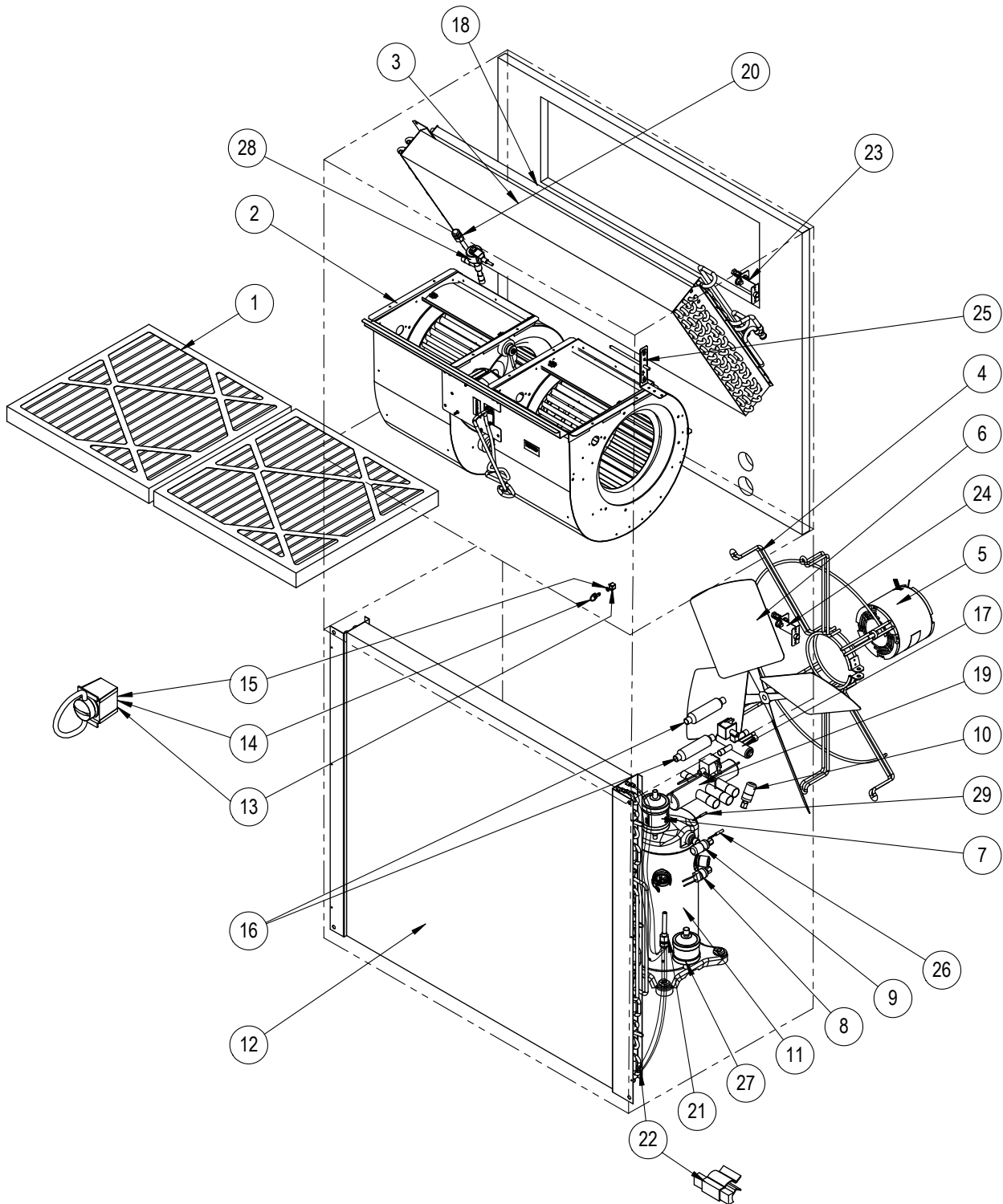

SEXP-1095

This drawing to be used for reference for pages 11 and 12

FUNCTIONAL COMPONENTS - STANDARD & RECESSED

Dwg. No.	Part Number	Description	W3VHY-R	W3VHY-S	W3VHY-T	W3VHYDR	W3VHYDS	W3VHYDT	W5VHY-R	W5VHY-S	W5VHY-T	W5VHYDR	W5VHYDS	W5VHYDT
1	7004-012	Air Filter 1" Throw-Away (20 x 20 x 1)	2	2	2	2	2	2	2	2	2	2	2	2
1	7003-085 ①	Air Filter 1" Washable (20 x 20 x 1)	2	2	2	2	2	2	2	2	2	2	2	2
1	7004-052 ①	Air Filter 2" Merv 8 (20 x 20 x 2)	2	2	2	2	2	2	2	2	2	2	2	2
1	7004-060 ①	Air Filter 2" Merv 11 (20 x 20 x 2)	2	2	2	2	2	2	2	2	2	2	2	2
1	7004-063 ①	Air Filter 2" Merv 13 (20 x 20 x 2)	2	2	2	2	2	2	2	2	2	2	2	2
2	900-398-0244BX	Blower Assembly	X	X	X	X	X	X						
2	900-397-0245BX	Blower Assembly							X	X	X	X	X	X
3	917-0405BX	Indoor Coil w/Distributor Assy.	X	X	X	X	X	X						
3	917-0406BX	Indoor Coil - Coated w/Distributor Assy.	O	O	O	O	O	O						
3	917-0376BX	Indoor Coil w/Distributor Assy.							X	X	X	X	X	X
3	917-0377BX	Indoor Coil - Coated w/Distributor Assy.							O	O	O	O	O	O
4	8200-049BX	Fan Motor Mount	X	X	X	X	X	X	X	X	X	X	X	X
4	8200-052BX ②	Fan Motor Mount - Stainless Steel	O	O	O	O	O	O	O	O	O	O	O	O
5	8106-079-0246BX	Condenser Motor	X	X	X	X	X	X	X	X	X	X	X	X
6	5151-060BX ③	Fan Blade	X	X	X	X	X	X	X	X	X	X	X	X
6	5151C060BX ③	Fan Blade - Coated	O	O	O	O	O	O	O	O	O	O	O	O
6	5151-054BX ③	Fan Blade	O	O	O	O	O	O	O	O	O	O	O	O
6	5151C054BX ③	Fan Blade - Coated	O	O	O	O	O	O	O	O	O	O	O	O
7	5201-020BX	H/P Liquid Filter Drier	X	X	X	X	X	X	X	X	X	X	X	X
8	8406-164BX	High Pressure Switch	X	X	X	X	X	X	X	X	X	X	X	X
9	8406-157BX	High Pressure Transducer	X	X	X	X	X	X	X	X	X	X	X	X
10	8408-158BX	Low Pressure Transducer	X	X	X	X	X	X	X	X	X	X	X	X
11	8000-498BX	Compressor ZPV0382E-2E9							X	X	X	X	X	X
11	8000-499BX	Compressor ZPV0282E-2E9	X	X	X	X	X	X						
12	917-0413BX	Outdoor Coil (Includes Distributor)	X	X	X	X	X	X						
12	917-0414BX	Outdoor Coil - Coated (Includes Distributor)	O	O	O	O	O	O						
12	917-0417BX	Outdoor Coil (Includes Distributor)							X	X	X	X	X	X
12	917-0418BX	Outdoor Coil - Coated (Includes Distributor)							O	O	O	O	O	O
13	1171-023	1/4 Turn Receptacle	X	X	X	X	X	X	X	X	X	X	X	X
14	1171-022	1/4 Turn Fastener	X	X	X	X	X	X	X	X	X	X	X	X
15	1171-024	1/4 Turn Retainer	X	X	X	X	X	X	X	X	X	X	X	X
16	5651-219	Check Valve				2	2	2				2	2	2
17	5650-051	Dehumidification 3-Way Valve				X	X	X				X	X	X
18	5051-221BX	Reheat Coil				X	X	X				X	X	X
19	5650-040BX	Reversing Valve	X	X	X	X	X	X	X	X	X	X	X	X
20	800-0461BX	Distributor Assembly - Indoor Coil	X	X	X	X	X	X						
20	800-0455BX	Distributor Assembly - Indoor Coil							X	X	X	X	X	X
21	800-0424BX	Distributor Assembly - Outdoor Coil	X	X	X	X	X	X						
21	800-0455BX	Distributor Assembly - Outdoor Coil							X	X	X	X	X	X
22	8408-058	Defrost Thermistor Sensor	X	X	X	X	X	X	X	X	X	X	X	X
23	910-2257BX	Supply Temp Sensor	X	X	X	X	X	X	X	X	X	X	X	X
24	910-2258BX	Return Temp Sensor	X	X	X	X	X	X	X	X	X	X	X	X
25	910-2106BX	Mixed Air Sensor	X	X	X	X	X	X	X	X	X	X	X	X
26	8408-063BX	Discharge Line Thermostat (DLT Sensor)	X	X	X	X	X	X	X	X	X	X	X	X
27	5220-013BX	Pulsation Dampener/Muffler	X	X	X	X	X	X	X	X	X	X	X	X

Continued on page 12

① Optional on these models

② Used with stainless steel cabinet option

③ Fan assemblies offered in blow thru or draw thru. Refer to nomenclature character 11 X, D, J or N.

X – Standard Component

O – Optional Component

FUNCTIONAL COMPONENTS – STANDARD & RECESSED

Dwg. No.	Part Number	Description	W3VHY-R	W3VHY-S	W3VHY-T	W3VHYDR	W3VHYDS	W3VHYDT	W5VHY-R	W5VHY-S	W5VHY-T	W5VHYDR	W5VHYDS	W5VHYDT
<i>Continued from page 11</i>														
28	905-0737BX	Electronic Expansion Valve Assembly E2V24	X	X	X	X	X	X						
28	905-0800BX	Electronic Expansion Valve Assembly E2V30							X	X	X	X	X	X
29	8408-054BX	Suction Temp Sensor	X	X	X	X	X	X	X	X	X	X	X	X
NS	910-2132BX	460V 2KVa Transformer Assembly (Non-ERV)			X			X			X			X
NS	910-2209BX	460V 3KVa Transformer Assembly (ERV Installed)			O			O			O			O
NS	5650-042BX	Rev. Valve Solenoid, Red Casing (Ranco)	X	X	X	X	X	X	X	X	X	X	X	X
NS	5650-046BX	Rev. Valve Solenoid, Black Casing (San Hua)	X	X	X	X	X	X	X	X	X	X	X	X
NS	5451-024	Tubing Isolation Grommet	2	2	2	2	2	2	2	2	2	2	2	2
NS	6031-009	Coremax Valve Core	2	2	2	2	2	2	2	2	2	2	2	2
NS	1171-028	Control Panel Door Clip	4	4	4	4	4	4	4	4	4	4	4	4
NS	1171-057	Control Panel Door Screw	4	4	4	4	4	4	4	4	4	4	4	4
NS	1171-027	Control Panel Door Screw Retainer	4	4	4	4	4	4	4	4	4	4	4	4
NS	3000-1779BX	Molded Plug for Reversing Valve (Blue Lead)	X	X	X	X	X	X	X	X	X	X	X	X
NS	3000-1780BX	Molded Plug for Dehum Valve (Purple/White Lead)				X	X	X				X	X	X

NS = Not Shown

X – Standard Component
O – Optional Component

Refer to drawing on page 10

This page intentionally left blank

CONTROL PANEL – STANDARD & RECESSED

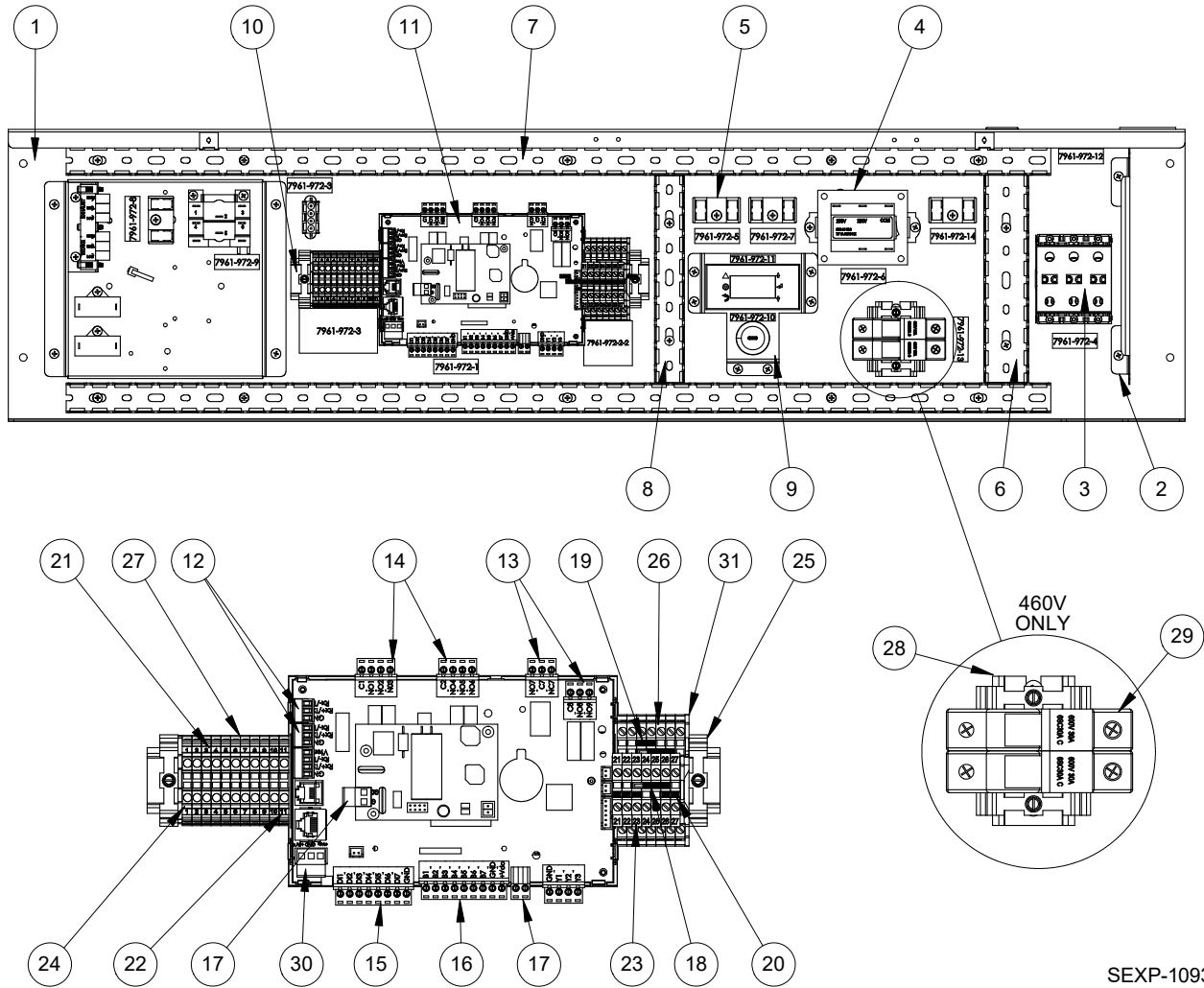

SEXP-1093

This drawing to be used for reference for pages 15 and 16

CONTROL PANEL - STANDARD & RECESSED

Dwg. No.	Part Number	Description	W3VHY-R	W3VHY-S	W3VHY-T	W3VHYDR	W3VHYDS	W3VHYDT	W5VHY-R	W5VHY-S	W5VHY-T	W5VHYDR	W5VHYDS	W5VHYDT
1	517-446BX	Control Panel	X	X	X	X	X	X	X	X	X	X	X	X
2	135-394BX	Wire Shield	X	X	X	X	X	X	X	X	X	X	X	X
3	8607-074BX	Power Terminal Block 2 Pole	X			X			X			X		
3	8607-070BX	Power Terminal Block 3 Pole		X	X		X	X		X	X		X	X
4	8407-065BX	Transformer 230/24VAC 75VA	X	X		X	X		X	X		X	X	
4	8407-072BX	Transformer 460/24VAC 75VA			X			X			X			X
5	8607-017BX	Terminal Block 240V 2 Terminal	2	2	3	2	2	3	2	2	3	2	2	3
6	8611-244-0700	2-1/4" x 1-1/2" Cable Duct 7"	X	X	X	X	X	X	X	X	X	X	X	X
7	8611-140-3300	2-1/4" x 1" Cable Duct 33"	2	2	2	2	2	2	2	2	2	2	2	2
8	8611-140-0700	2-1/4" x 1" Cable Duct 7"	X	X	X	X	X	X	X	X	X	X	X	X
9	910-2266BX	PLD Display Assembly	X	X	X	X	X	X	X	X	X	X	X	X
10	113-820BX	12" DIN Rail	X	X	X	X	X	X	X	X	X	X	X	X
11	8301-109-001BX	UPC3 C2 - Variable Speed	X	X	X	X	X	X	X	X	X	X	X	X
12	8611-192	3-PIN Circuit Board Connector	2	2	2	2	2	2	2	2	2	2	2	2
13	8611-147	3-PIN Circuit Board Connector	2	2	2	2	2	2	2	2	2	2	2	2
14	8611-148	4-PIN Circuit Board Connector	3	3	3	3	3	3	3	3	3	3	3	3
15	8611-185	8-PIN Circuit Board Connector	X	X	X	X	X	X	X	X	X	X	X	X
16	8611-149	9-PIN Circuit Board Connector	X	X	X	X	X	X	X	X	X	X	X	X
17	8611-183	2-PIN Circuit Board Connector	2	2	2	2	2	2	2	2	2	2	2	2
18	8611-195	Jumper 4 Position	X	X	X	X	X	X	X	X	X	X	X	X
20	8611-282	Jumper 1 Position	4	4	4	4	4	4	4	4	4	4	4	4
21	8607-056	Terminal Designation (1-10)	2	2	2	2	2	2	2	2	2	2	2	2
22	8607-055	Terminal Designation (11-20)	2	2	2	2	2	2	2	2	2	2	2	2
23	8607-054	Terminal Designation (21-30)	2	2	2	2	2	2	2	2	2	2	2	2
24	8611-151	Terminal Block End Cap for DIN Rail	X	X	X	X	X	X	X	X	X	X	X	X
25	8611-144	End Clamp for DIN Rail	2	2	2	2	2	4	2	2	2	2	2	4
26	8611-058	Double Level Terminal Block	7	7	7	7	7	7	7	7	7	7	7	7
27	8611-150BX	Terminal Block for DIN Rail RS485	11	11	11	11	11	11	11	11	11	11	11	11
28	113-943BX	35MM DIN Rail 2-1/2"			X			X			X			X
29	8614-058BX	2-POLE Enclosed Fuse Holder			X			X			X			X
30	8611-237	3-PIN Circuit Board Connector	X	X	X	X	X	X	X	X	X	X	X	X
31	8611-221	End Cover	X	X	X	X	X	X	X	X	X	X	X	X
NS	8614-042BX	7A Class CC Fuse (Non-ERV units)			2			2			2			2
NS	8614-043BX	10A Class CC Fuse (Unit with ERV Only)			2			2			2			2
NS	8615-038BX	Circuit Breaker 35A 2 Pole ①	X			X			X					
NS	8615-039BX	Circuit Breaker 45A 2 Pole ①							X					
NS	8615-040BX	Circuit Breaker 50A 2 Pole ①										X		
NS	8615-051BX	Circuit Breaker 25A 3 Pole ①		X										
NS	8615-052BX	Circuit Breaker 30A 3 Pole ①				X								
NS	8615-042BX	Circuit Breaker 35A 3 Pole ①							X				X	
NS	8615-095BX	Toggle Disconnect			X			X			X			X
NS	8615-096BX	Disconnect Cover			X			X			X			X

Continued on page 16

NS = Not Shown

X – Standard Component

① Circuit breakers listed are for units without electric heat, "OZ" models.
See heater replacement parts manual for units with electric heat.

O – Optional Component

CONTROL PANEL – STANDARD & RECESSED

Dwg. No.	Part Number	Description	W3VHY-R	W3VHY-S	W3VHY-T	W3VHYDR	W3VHYDS	W3VHYDT	W5VHY-R	W5VHY-S	W5VHY-T	W5VHYDR	W5VHYDS	W5VHYDT
<i>Continued from page 15</i>														
NS	4096-184	Wiring Diagram	X			X			X			X		
NS	4096-284	Wiring Diagram		X			X			X			X	
NS	4096-384	Wiring Diagram			X			X			X			X
NS	910-2265BX	Blower Speed Plug Harness	X	X	X	X	X	X	X	X	X	X	X	X
NS	3000-1799BX	Blower Power Plug Harness	X	X	X	X	X	X	X	X	X	X	X	X
NS	3000-1758BX	Compressor Harness	X			X			X			X		
NS	3000-1759BX	Compressor Harness		X	X		X	X		X	X		X	X

NS = Not Shown

X – Standard Component
O – Optional Component

Refer to drawing on page 14

BLOWER ASSEMBLY

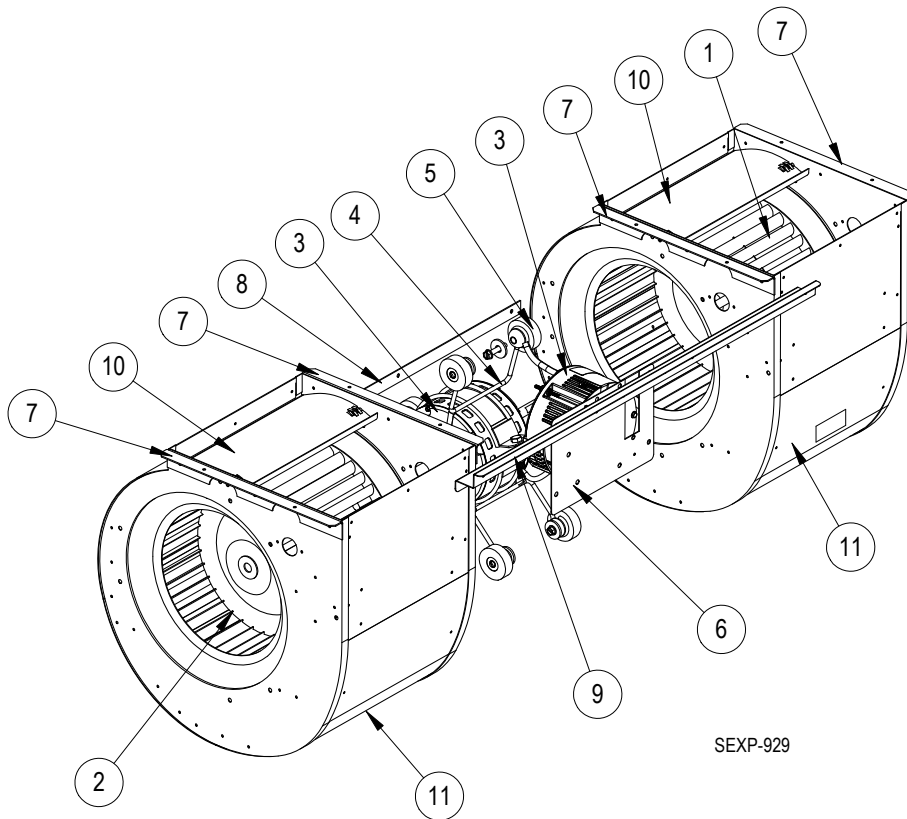

SEXP-929

900-397-0245BX
900-398-0244BX

Dwg No.	Part Number	Description	900-397-0245BX	900-398-0244BX
1	5152-011BX	Blower Wheel (CW) 1/2" 10-8DD	X	X
2	5152-012BX	Blower Wheel (CCW) 1/2" 10-8DD	X	X
3	8106-073-0244BX	Programmed Blower Motor & Control (230/208V)		X
3	8107-032-0245BX	Programmed Blower Motor & Control (230/208V)	X	
3	C8106-073-0244	Programmed Control Only (230/208V)		O
3	C8107-032-0245	Programmed Control Only (230/208V)	O	
4	8200-040BX	Motor Mount	X	X
5	5451-011	Grommets	6	6
6	112-775BX	Motor Control Bracket	X	X
7	105-880BX	Side Angle	4	4
8	105-881BX	Back Brace	X	X
9	103-541BX	Front Mounting Offset	X	X
10	144-166BX	Diffuser	2	2
11	151-101BX	Blower Housing	2	2

X – Standard Component
O – Optional Component

INVERTER DRIVE ASSEMBLY – 230V 1 PHASE

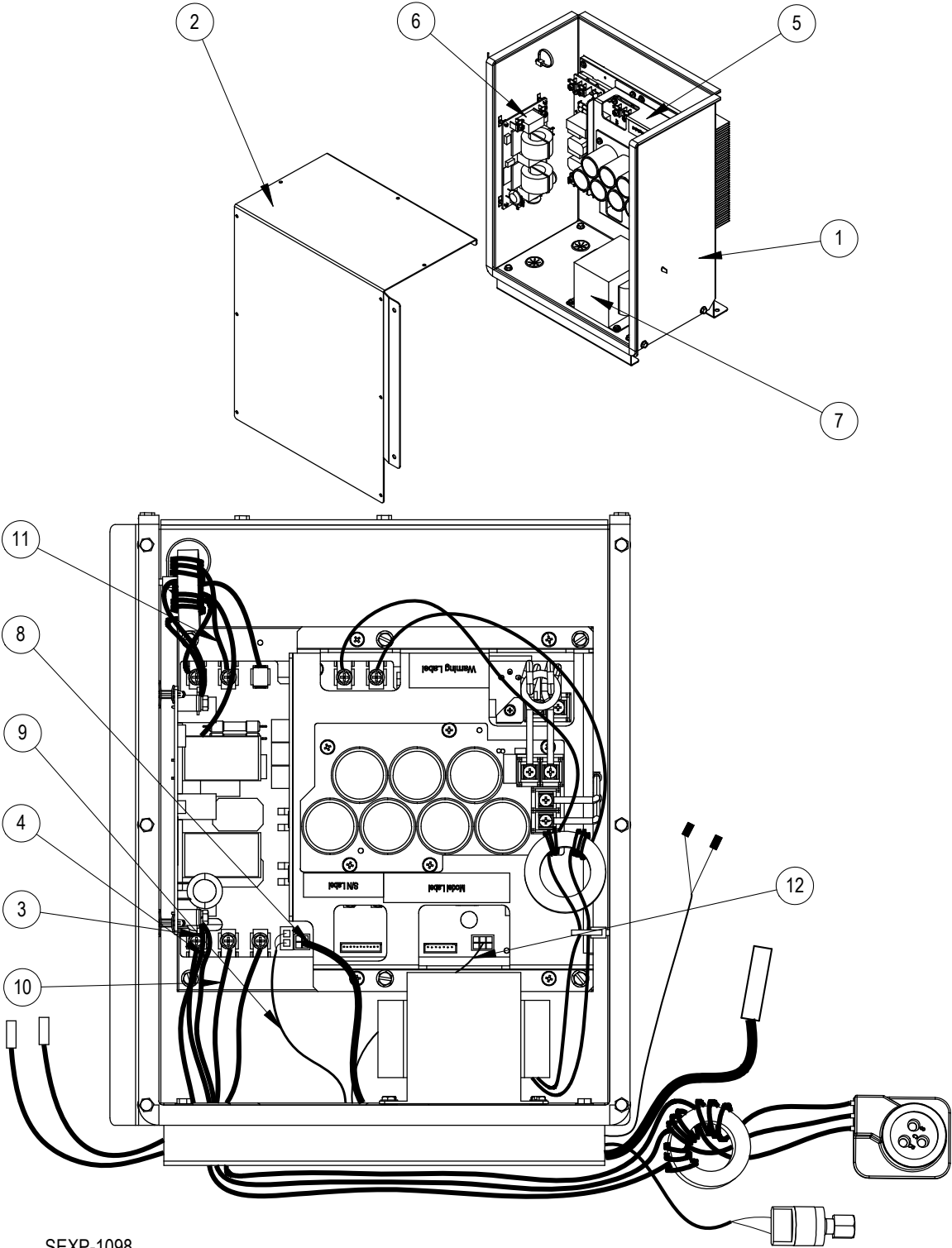

SEXP-1098

INVERTER DRIVE ASSEMBLY - 230V 1 PHASE

Dwg. No.	Part Number	Description	W3VHY-R	W3VHYDR	W5VHY-R	W5VHYDR
1	527-634BX	Inverter Base Assembly	X	X	X	X
2	115-362BX	Inverter Cover	X	X	X	X
3	3010-070A	EA2-112-GR6-50	X	X	X	X
4	3010-069A	EC2-112-GR6-51	X	X	X	X
5	8003-001BX	Inverter Drive EV2055M-C9-291	X	X		
5	8003-004BX	Inverter Drive EV2080M-C9-291			X	X
6	8004-001BX	EMI Filter Board 230-1PH	X	X	X	X
7	8005-001BX	Choke 230-1PH	X	X	X	X
8	8408-063BX	Temp Sensor Assembly	X	X	X	X
9	8406-164BX	High Pressure Switch Assembly	X	X	X	X
10	3000-1758BX	Wire Assembly Drive to Compressor	X	X	X	X
11	3000-1755BX	Wire Assembly Filter to Drive	X	X	X	X
12	3000-1748BX	Communication Cable	X	X	X	X
NS	4210-100	Wire Diagram	X	X	X	X

INVERTER DRIVE ASSEMBLY - 230V 3 PHASE & 460V 3 PHASE

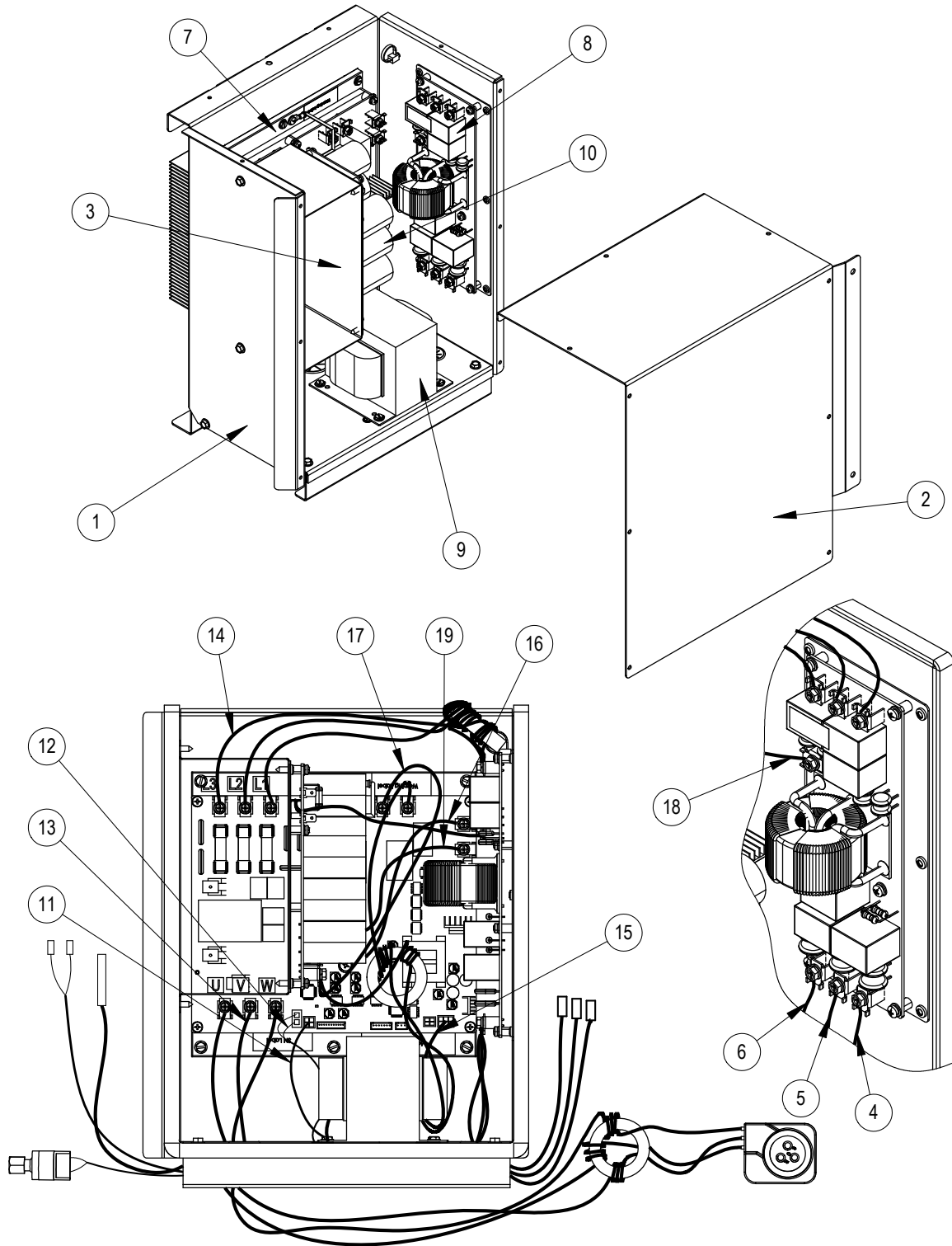

SEXP-1096

INVERTER DRIVE ASSEMBLY – 230V 3 PHASE & 460V 3 PHASE

Dwg. No.	Part Number	Description	W3VHY-S	W3VHY-T	W3VHYDS	W3VHYDT	W5VHY-S	W5VHY-T	W5VHYDS	W5VHYDT
1	527-633BX	Inverter Base Assembly	X	X	X	X	X	X	X	X
2	515-362BX	Inverter Cover	X	X	X	X	X	X	X	X
3	103-559BX	Capacitor Board Bracket	X	X	X	X	X	X	X	X
4	3010-070A	EA2-112-GR6-50	X	X	X	X	X	X	X	X
5	3010-069A	EC2-112-GR6-51	X	X	X	X	X	X	X	X
6	3010-071A	EE2-112-GR6-52	X	X	X	X	X	X	X	X
7	8003-002BX	Inverter Drive EV2055M-J9-291	X		X					
7	8003-003BX	Inverter Drive EV2055M-K9-291		X		X				
7	8003-005BX	Inverter Drive EV2080M-J9-291					X		X	
7	8003-006BX	Inverter Drive EV2080M-K9-291						X		X
8	8004-002BX	EMI Filter Board 230-3PH	X		X		X		X	
8	8004-003BX	EMI Filter Board 460-3PH		X		X		X		X
9	8005-002BX	Choke 230-3PH	X		X		X		X	
9	8005-003BX	Choke 460-3PH		X		X		X		X
10	8006-001BX	Capacitor Board w/Base - 5.5KW 230-3Ph	X		X					
10	8006-002BX	Capacitor Board w/Base - 5.5KW 460-3Ph		X		X				
10	8006-003BX	Capacitor Board w/Base - 8KW 230-3Ph					X		X	
10	8006-004BX	Capacitor Board w/Base - 8KW 460-3Ph						X		X
11	8408-063BX	Temp Sensor Assembly	X	X	X	X	X	X	X	X
12	8406-164BX	High Pressure Switch Assembly	X	X	X	X	X	X	X	X
13	3000-1759BX	Wire Assembly Drive to Compressor	X	X	X	X	X	X	X	X
14	3000-1756BX	Wire Assembly Filter to Drive	X		X		X		X	
14	3000-1757BX	Wire Assembly Filter to Drive		X		X		X		X
15	3000-1748BX	Communication Cable	X	X	X	X	X	X	X	X
16	3010-074	EA2-12-GG	X	X	X	X	X	X	X	X
17	3010-075	EC2-12-CG	X	X	X	X	X	X	X	X
18	3010-076	EF2-06-CG	X	X	X	X	X	X	X	X
19	3000-1783BX	Drive to Capacitor Board	X		X		X		X	
19	3000-1784BX	Drive to Capacitor Board		X		X		X		X
NS	4210-200	Wiring Diagram	X		X		X		X	
NS	4210-300	Wiring Diagram		X		X		X		X