REPLACEMENT PARTS MANUAL

AGRI-TEC Unit

Models:

A36RYHA A36RYHD

Contents

<u>Description</u>	<u>Page</u>
External Parts	
♦ Exploded View	2
♦ Usage List	3
Internal Parts	
♦ Exploded View	4
♦ Usage List	5
Functional Components	
♦ Exploded View	6
♦ Usage List	7
Control Panel	
♦ Layout View	8
♦ Usage List	9
Filter Door/Vent Option	
♦ Layout View	10
♦ Usage List	11

General Notes

- Revised and/or additional pages may be issued from time to time.
- A complete and current manual consists of pages shown in the following contents section.

Important

- Contact the installing and/or local Bard distributor for all parts requirements. Make sure to have the complete model and serial number available from the unit rating plates.



Climate Control Solutions

Bard Manufacturing Company, Inc.
Bryan, Ohio 43506
www.bardhvac.com

Manual: 2110-1475B
Supersedes: 2110-1475A
Date: 4-5-24

EXTERNAL PARTS

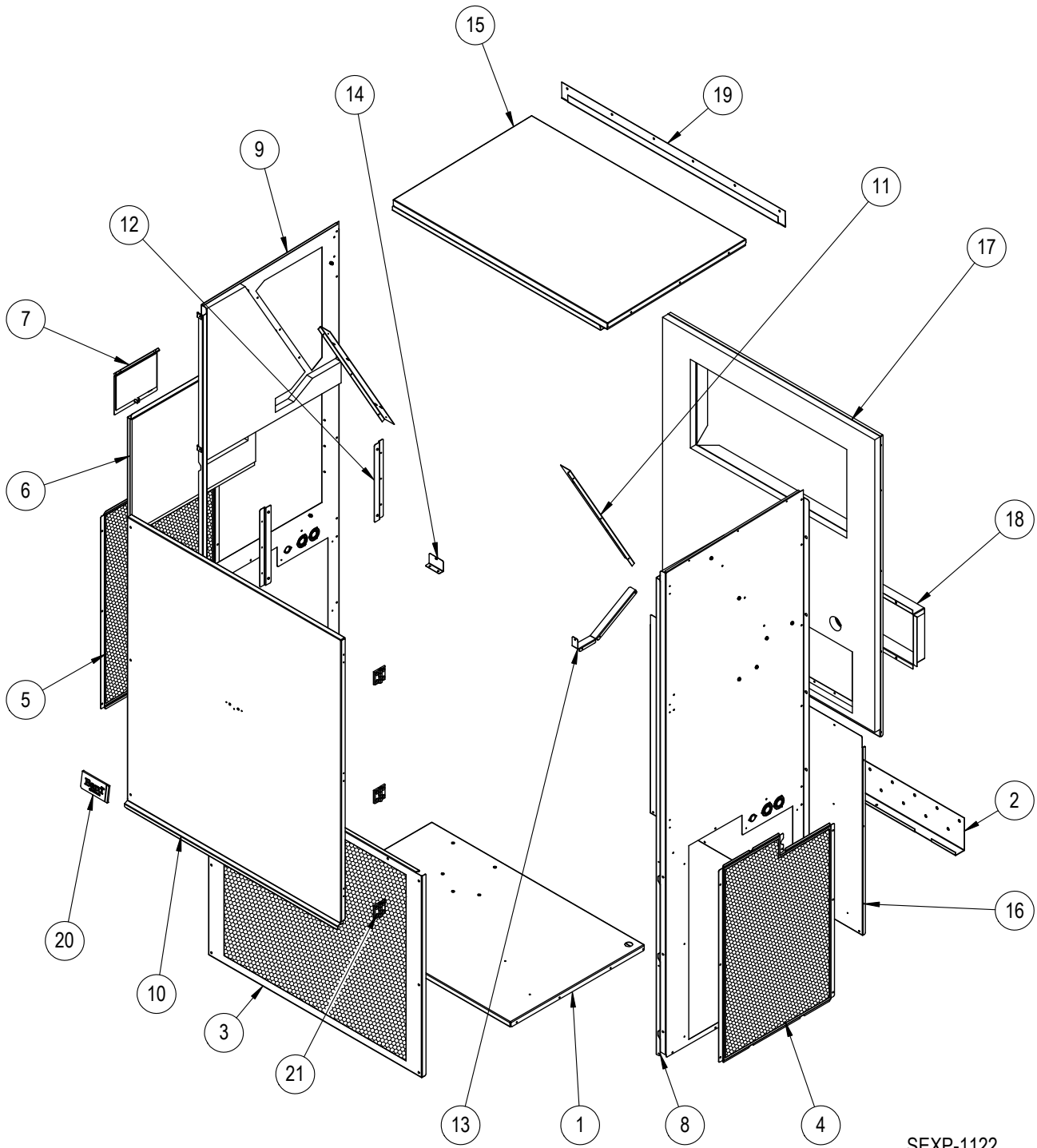

SEXP-1122

EXTERNAL PARTS

Dwg No.	Part Number	Description	A36RYHA	A36RYHD
1	127-626BX	Unit Base	X	X
2	113-140BX	Bottom Support Bracket	X	X
3	119-157-*BX	Front Grille	X	X
4	119-156-*BX	Side Grille (Right)	X	X
5	119-158-*BX	Side Grille (Left)	X	X
6	533-357-*BX	Control Panel Cover (Outer)	X	X
7	153-717-*BX	Disconnect Access Door	X	X
8	501-1160-*BX	Right Side	X	X
9	501-1161-*BX	Left Side	X	X
10	553-767-*BX	Front Door	X	X
11	147-059	Coil Support Bracket	2	2
12	113-986	Inner Control Panel Door Bracket	2	2
13	113-980	Drain Pan Bracket (Right)	X	X
14	113-979BX	Drain Pan Bracket (Left)	X	X
15	507-419-*BX	Top	X	X
16	109-483BX	Lower Back	X	X
17	509-482BX	Upper Back	X	X
18	111-375BX	Supply Air Frame Assembly	X	X
19	113-149-*BX	Top Rain Flashing	X	X
20	5252-033	Bard Nameplate	X	X
21	5400-010BX	Metal Leaf Hinge	3	3

* Exterior cabinet parts are manufactured with various paint color options. To ensure the proper paint color is received, include the complete model and serial number of the unit for which cabinet parts are being ordered.

INTERNAL PARTS

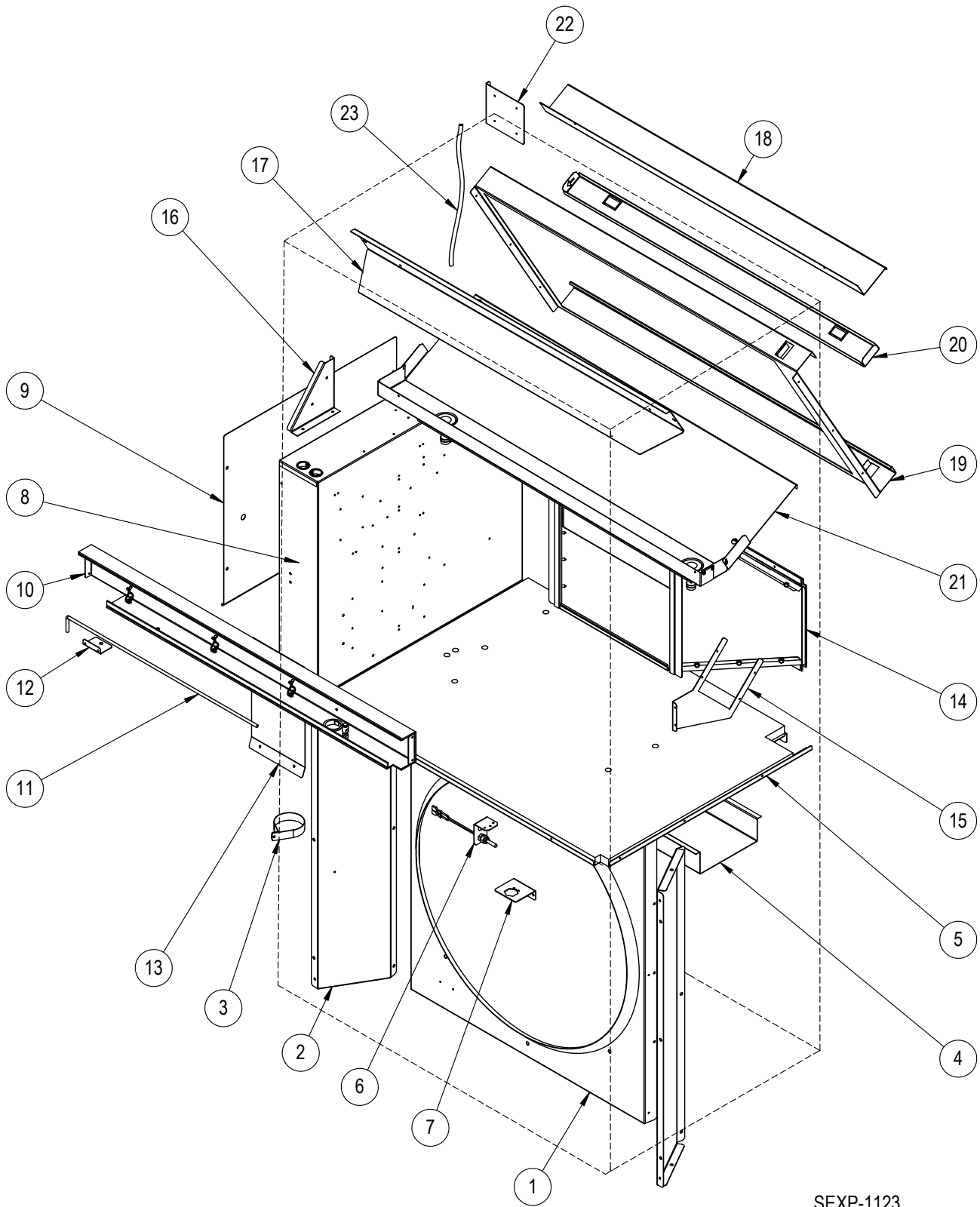

SEXP-1123

INTERNAL PARTS

Dwg. No.	Part Number	Description	A36RYHA	A36RYHD
1	125-113BX	Fan Shroud	X	X
2	125-114BX	Fan Shroud Side Access Cover	2	2
3	8550-011	Filter Drier Strap	X	X
4	165-631BX	Wire Channel	X	X
5	521-649BX	Condenser Partition	X	X
6	910-2264BX	Outdoor Temp Sensor Assembly	X	X
7	113-985BX	Hot Gas Bypass Valve Bracket	X	X
8	Control Panel Assy.	See CONTROL PANEL on pages 8 and 9	X	X
9	133-358BX	Control Panel Cover (Inner)	X	X
10	565-630BX	C-Channel Support Assembly	X	X
11	8602-120BX	Prop Rod	X	X
12	113-976	Prop Rod Bracket	X	X
13	141-594BX	Blower Support Bracket	X	X
14	921-0128BX	Blower Duct Assembly	X	X
15	113-978BX	Right Electric Heat Bracket	X	X
16	113-977BX	Left Electric Heat Bracket	X	X
17	137-1016BX	Evaporator Fill Plate	X	X
18	131-197BX	Filter Fill Plate	X	X
19	131-198BX	Filter Frame	X	X
20	131-199BX	Filter Tray	X	X
21	523-173BX	Drain Pan Assembly	X	X
22	105-1537BX	Filter Switch Bracket	X	X
23	5452-008-1500	15" Silicone Hose	X	X

FUNCTIONAL COMPONENTS

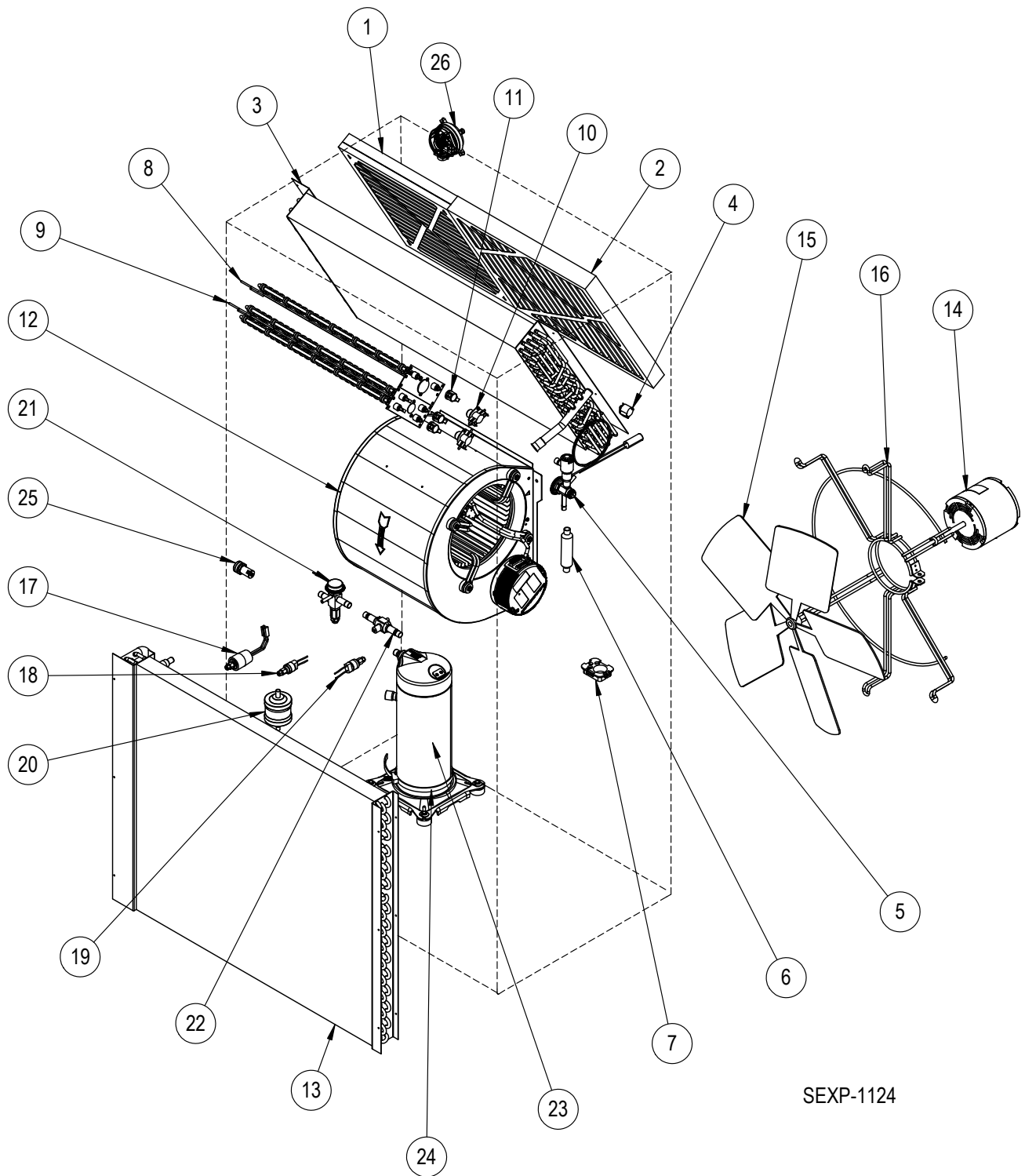

FUNCTIONAL COMPONENTS

Dwg. No.	Part Number	Description	A36RYHA - 10 kW	A36RYHA - 15 kW	A36RYHD - 10 kW	A36RYHD - 15 kW
1	7004-035	Air Filter 2" Merv 8 (16 x 20 x 2)	X	X	X	X
1	7004-073	Air Filter 2" Merv 11 (16 x 20 x 2)	O	O	O	O
1	7004-070	Air Filter 2" Merv 13 (16 x 20 x 2)	O	O	O	O
2	7004-052	Air Filter 2" Merv 8 (20 x 20 x 2)	X	X	X	X
2	7004-060	Air Filter 2" Merv 11 (20 x 20 x 2)	O	O	O	O
2	7004-063	Air Filter 2" Merv 13 (20 x 20 x 2)	O	O	O	O
3	917-0541BX	Evaporator Coil	X	X	X	X
3	917-0543BX	Evaporator Coil - Coated	O	O	O	O
4	8408-048BX	Freeze Protection Thermostat	X	X	X	X
5	5651-258BX	Distributor & Thermostatic Expansion Valve Assembly	X	X	X	X
6	5651-219BX	Check Valve	X	X	X	X
7	5451-024	Tubing Isolation Grommet	X	X	X	X
8	8604-118BX	Electric Heat Strip - 5kw		X		X
9	8604-116BX	Electric Heat Strip - 10kw	X	X	X	X
10	8402-229BX	Primary Limit	1	2	1	2
11	8402-138BX	Secondary Limit	2	3	2	3
12	5154-007-0248BX	Programmed Blower Assembly	X	X	X	X
13	5051-251BX	Condenser Coil	X	X	X	X
13	5054-251BX	Condenser Coil - Coated	O	O	O	O
14	8106-054-0247BX	Programmed Condenser Fan Motor	X	X	X	X
15	5151-060BX	Fan Blade - 24" 5 Blade	X	X	X	X
16	8200-049BX	Fan Motor Mount	X	X	X	X
17	8406-112BX	Low Ambient Control (LAC)	X	X	X	X
18	8406-142BX	High Pressure Switch	X	X	X	X
19	8406-135BX	Low Pressure Switch	X	X	X	X
20	5201-021BX	Filter Drier	X	X	X	X
21	5651-257BX	Hot Gas Bypass Valve	X	X	X	X
22	5651-256BX	Refrigerant Ball Valve - 1/2" x 1/2"	X	X	X	X
23	8000-278BX	Compressor	X	X		
23	8000-312BX	Compressor			X	X
24	8605-019BX	Crankcase Heater	X	X	X	X
25	8611-199BX	Red Indicator Light - 24VAC	X	X	X	X
26	8301-104BX	Filter Pressure Switch	X	X	X	X
NS	6031-009	Coremax Valve Core	2	2	2	2
NS	1012-360	Control Panel Door Screw	2	2	2	2
NS	1012-130	Torx Panhead Screw - Slate	12	12	12	12

NS = Not Shown

X – Standard Component

O – Optional Component

CONTROL PANEL

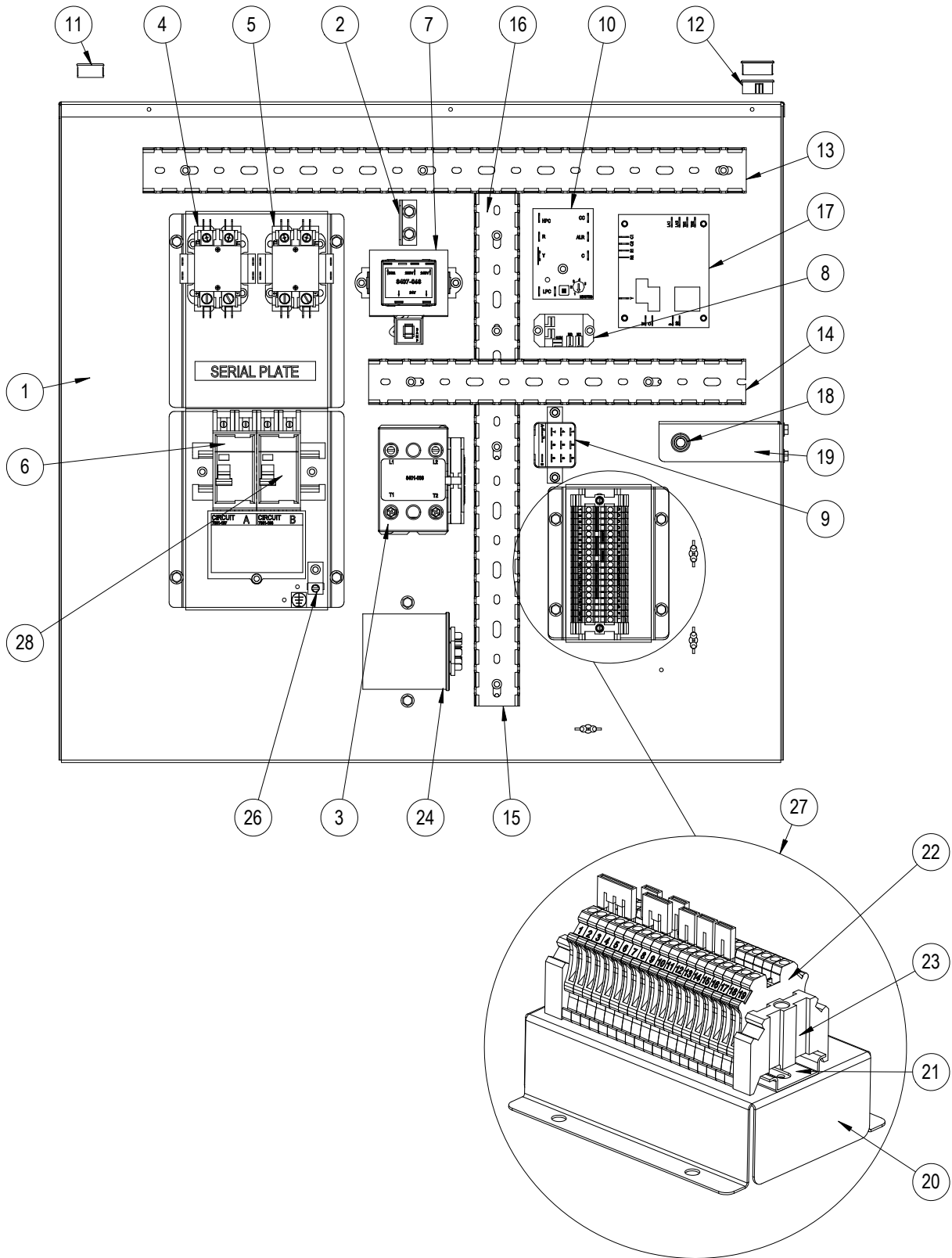

SEXP-1125 B

CONTROL PANEL

Dwg. No.	Part Number	Description	A36RYHA - 10 kW	A36RYHA - 15 kW	A36RYHD - 10 kW	A36RYHD - 15 kW
1	517-451BX	Control Panel	X	X	X	X
2	141-595BX	Plug Support Bracket - 3 Pin	X	X	X	X
3	8401-038BX	Compressor Contactor 2-Pole 40 Amp	X	X	X	X
4	8401-025BX	Electric Heat Contactor 2-Pole 40 Amp	X	X	X	X
5	8401-006BX	Electric Heat Contactor 2-Pole 20 Amp		X		X
6	8615-041BX	Circuit Breaker 60A 2-Pole	X	X	X	X
7	8407-068BX	TRANSFORMER 208/240-24 50VA	X	X	X	X
8	8201-130BX	Pilot Duty Relay -SPDT	X	X	X	X
9	8201-159BX	Pilot Duty Relay -DPDT	X	X	X	X
10	8201-176BX	Compressor Control Module	X	X	X	X
11	8611-016	Universal Bushing	X	X	X	X
12	8611-117	Snap Bushing - 1"	2	2	2	2
13	8611-140-2000	Cable Duct - 20"	X	X	X	X
14	8611-140-1208	Cable Duct - 12.5"	X	X	X	X
15	8611-140-1000	Cable Duct - 10"	X	X	X	X
16	8611-140-0508	Cable Duct - 5.5"	X	X	X	X
17	8201-166BX	Fan Logic Control Board	X	X	X	X
18	8406-165BX	Dirty Filter Alarm Reset Switch	X	X	X	X
19	113-987BX	Reset Switch Bracket	X	X	X	X
20	127-629BX	Low Voltage Terminal Strip Riser	X	X	X	X
21	8611-223	Din Rail - 5"	X	X	X	X
22	8611-150	Low Voltage Terminal Block (Individual)	19	19	19	19
23	8611-144	End Clamp for DIN Rail	2	2	2	2
24	8552-052BX	Compressor Capacitor - 45/5MFD 370V	X	X		
24	8552-062BX	Compressor Capacitor - 60/5MFD 370V			X	X
25	8550-008BX	Capacitor Strap	X	X	X	X
26	8611-006	Ground Lug Terminal	X	X	X	X
27	910-2271BX	Low Voltage Assembly	X	X	X	X
28	8615-038BX	Circuit Breaker 35A 2-Pole	X		X	
NS	3000-1796BX	Blower Power Plug/Harness	X	X	X	X
NS	3000-1797BX	Blower Speed Plug/Harness	X	X	X	X
NS	3000-1224BX	Compressor Plug/Harness	X	X	X	X
NS	3003-149BX	Control Panel Wire Harness	X	X	X	X
NS	3000-1798BX	Electric Heat Harness - 3 Plug (Male)	X	X	X	X
NS	4215-101	Unit Wiring Diagram	X	X	X	X
NS	4216-101	Electric Heat Wiring Diagram		X		X
NS	4216-102	Electric Heat Wiring Diagram	X		X	

FILTER DOOR/VENT OPTION

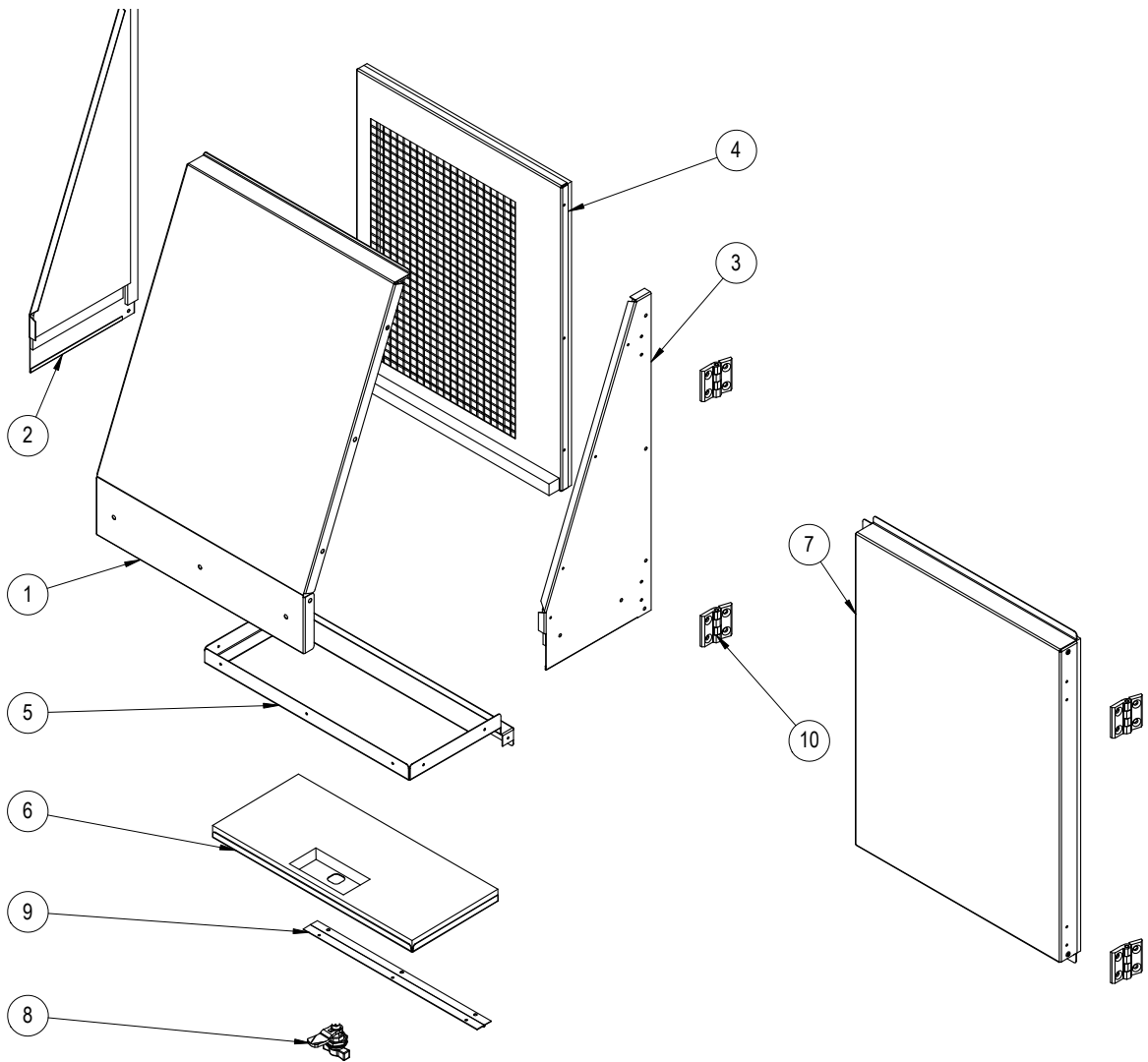

SEXP-1126

FILTER DOOR/VENT OPTION

Dwg No.	Part Number	Description	BOP	MOFAD
1	539-466-*BX	MOFAD Front Assembly		X
2	539-467-*BX	MOFAD Left Side Assembly		X
3	539-468-*BX	MOFAD Right Side Assembly		X
4	539-469BX	MOFAD Inner Frame Assembly		X
5	139-470-*BX	MOFAD Damper Door Frame		X
6	553-768-*BX	MOFAD Damper Door Assembly		X
7	543-266-*BX	BOP Filter Access Cover Assembly	X	
8	1171-072	Wing Knob Latch		X
9	5400-002BX	Piano Hinge 13"		X
10	5400-010	Metal Leaf Hinge	2	2
NS	1012-130	Torx Panhead Screw - Slate	4	4
NS	1012-364	Torx Panhead Machine Screw - Stainless	6	6

* Exterior cabinet parts are manufactured with various paint color options. To ensure the proper paint color is received, include the complete model and serial number of the unit for which cabinet parts are being ordered.

NS = Not Shown